

Concrete Removal

NOTES:
* Field Verify (Match Existing)

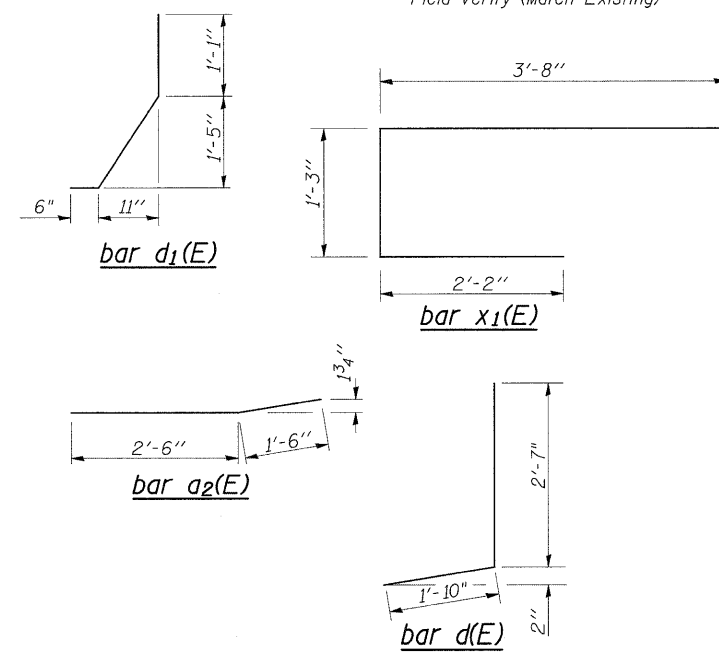
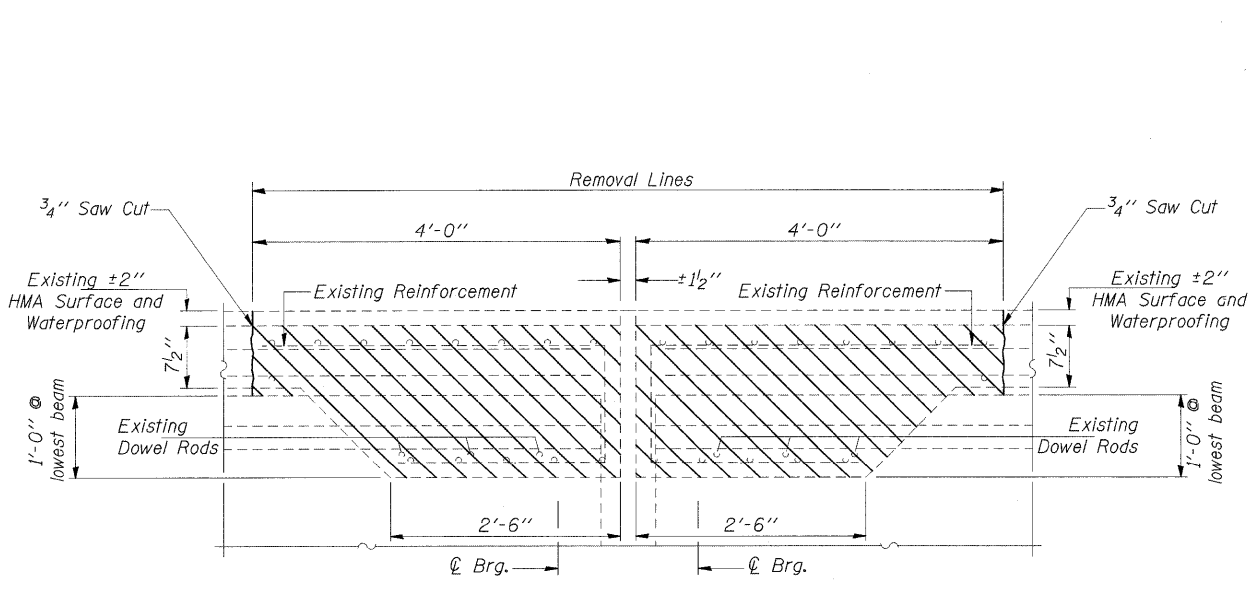

BILL OF MATERIAL (16 LOCATIONS)

Bar No.	Size	Length	Shape
a2(E)	288 #6	4'-0"	—
a7(E)	288 #7	16'-5"	—
a8(E)	640 #6	6'-6"	—
a9(E)	288 #7	18'-5"	—
d(E)	288 #5	4'-5"	J
d1(E)	288 #5	3'-3"	J
x1(E)	1792 #6	7'-1"	□
Concrete Superstructure	Cu. Yd.	267.9	
Concrete Removal	Cu. Yd.	243.2	
Reinforcement Bars, Epoxy Coated	Pound	49850	

Reinforcement bars designated (E) shall be epoxy coated.

PIER #'S 1, 4, 7, 10, 13, 16, 19, & 22
JOINT REPLACEMENT DETAILS
ALEXANDER COUNTY
STRUCTURE NO. 002-0001 (N.B.)
STRUCTURE NO. 002-0002 (S.B.)