

DETAIL OF DRAINAGE STRUCTURE FOR RT. STA. 1783+62.82 IL 13 (CENTER)

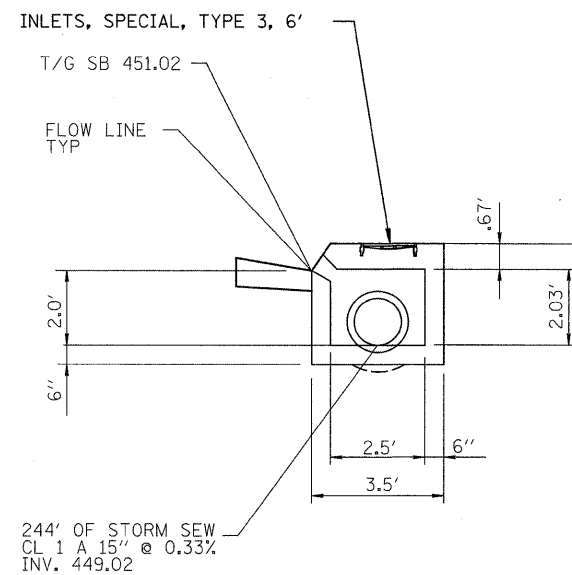

22 DETAIL OF DRAINAGE STRUCTURE FOR RT. STA. 791+48.84 IL 13 EB

FILE NAME =	USER NAME = #USER#	DESIGNED -	REVISED -	STATE OF ILLINOIS DEPARTMENT OF TRANSPORTATION	DETAILS: DRAINAGE STRUCTURE FOR 791+48.84 IL 13 RT, 1783+62.82 IL 13			F.A. RTE.	SECTION	COUNTY	TOTAL SHEETS	SHEET NO.			
#FILE#		DRAWN -	REVISED -		SCALE: N.T.S.	SHEET NO.	OF	SHEETS	STA.	TO STA.	*	(X1-6-2)K-1(1X-1)R-4	WILLIAMSON	194	126
	PLOT SCALE = #SCALE#	CHECKED -	REVISED -								*	I-57/IL 13 (FAI 57/FAP 331)			CONTRACT NO. 78194
	PLOT DATE = #DATE#	DATE -	REVISED -									ILLINOIS FED. AID PROJECT			