

CODE NO.	ITEM	UNIT	TOTAL QUANTITY URBAN	CONSTRUCTION CODE	
				80% FED, 20% STATE	80% FED, 20% STATE
				BRIDGE 0004 SN: 022-8300	RETAINING WALL 0044 SN: 022-W001
28001100	TEMPORARY EROSION CONTROL BLANKET	SQ YD	2,235	2,235	
28100107	STONE RIPRAP, CLASS A4	SQ YD	123	123	
30300001	AGGREGATE SUBGRADE IMPROVEMENT	CU YD	306	306	
30300112	AGGREGATE SUBGRADE IMPROVEMENT 12"	SQ YD	2,629	2,629	
31101200	SUBBASE GRANULAR MATERIAL, TYPE B 4"	SQ YD	2,773	2,773	
40603235	POLYMERIZED HOT-MIX ASPHALT BINDER COURSE, IL-19.0, N70				
40603090	HOT-MIX ASPHALT BINDER COURSE, IL-19.0, N90	TON	218	218	
40603240	POLYMERIZED HOT-MIX ASPHALT BINDER COURSE, IL-19.0, N90	TON	92	92	
40605026	POLYMERIZED HOT-MIX ASPHALT SURFACE COURSE, STONE MATRIX ASPHALT, 9.5, MIX "F", N80	TON	240	240	
44000100	PAVEMENT REMOVAL	SQ YD	3,210	3,210	
44004250	PAVED SHOULDER REMOVAL	SQ YD	1,706	1,706	
44200535	CLASS A PATCHES, TYPE IV, 8 INCH	SQ YD	606	606	
44200944	CLASS B PATCHES, TYPE IV, 8 INCH	SQ YD	114	114	
48101202	AGGREGATE SHOULDERS, TYPE B	CU YD	296	296	
50200100	STRUCTURE EXCAVATION	CU YD	3,234	2,890	344
50200450	REMOVAL AND DISPOSAL OF UNSUITABLE MATERIAL FOR STRUCTURES	CU YD	306	306	

REVISED SHEET 5/25/2021

REV-SEP

MODEL: D:\p\c\i\...
 FILE NAME: P:\000038...
 IDOT\000058\01\002 (ENG) - PTB 195-016 Phase II Ver. Ver\Engineering\WO 1 - IL\24\3B\500 Drawings\502 CADD Sheets\162M69-sh-50002.dgn



USER NAME = khejtmanek	DESIGNED - KH	REVISED -
DRAWN - KM	REVISIONS -	
PLOT SCALE = 2.0000' / in.	CHECKED - AP	REVISED -
PLOT DATE = 3/10/2021	DATE - 3/11/2021	REVISED -

STATE OF ILLINOIS
DEPARTMENT OF TRANSPORTATION

SCALE: NONE		SHEET 2	OF 6	SHEETS	STA.	TO STA.
-------------	--	---------	------	--------	------	---------

SUMMARY OF QUANTITIES

F.A.P. RTE.	SECTION	COUNTY	TOTAL SHEETS	SHEET NO.
344	2020-196-T	DUPAGE	122	5
CONTRACT NO. 62M69			ILLINOIS FED. AID PROJECT	

MODEL: Default
 FILE NAME: P:\00058 - IDOT\00058\01-002 (ENG) - PTB 195-016 Phase II Vpr Vpr\Engineering\WO 1 - IL024L3B\500 Drawings\502 CADD Sheets\ID162M69-sh-50004.dgn

CODE NO.	ITEM	UNIT	TOTAL QUANTITY URBAN	CONSTRUCTION CODE	
				80% FED, 20% STATE	80% FED, 20% STATE
				BRIDGE 0004 SN: 022-8300	RETAINING WALL 0044 SN: 022-W001
54010805	PRECAST CONCRETE BOX CULVERTS 8' X 5'	FOOT	412.0	412.0	
54011005	PRECAST CONCRETE BOX CULVERTS 10' X 5'	FOOT	206.0	206.0	
550A0340	STORM SEWERS, CLASS A, TYPE 2 12"	FOOT	11	11	
55100500	STORM SEWER REMOVAL 12"	FOOT	45	45	
59100100	GEOCOMPOSITE WALL DRAIN	SQ YD	1,266.8	766.8	500
59300100	CONTROLLED LOW-STRENGTH MATERIAL	CU YD	300	300	
60270050	DRAINAGE STRUCTURES, TYPE 4 WITH TWO TYPE 20 FRAME AND GRATES	EACH	1	1	
60602800	CONCRETE GUTTER, TYPE B	FOOT	403		403
* 63000001	STEEL PLATE BEAM GUARDRAIL, TYPE A, 6 FOOT POSTS	FOOT	500	500	
* 63100045	TRAFFIC BARRIER TERMINAL, TYPE 2	EACH	1	1	
* 63100167	TRAFFIC BARRIER TERMINAL, TYPE 1 (SPECIAL) TANGENT	EACH	1	1	
63200310	GUARDRAIL REMOVAL	FOOT	444	444	
* 66900200	NON-SPECIAL WASTE DISPOSAL	CU YD	1,340	1,340	
* 66900530	SOIL DISPOSAL ANALYSIS	EACH	2	2	①
* 66901001	REGULATED SUBSTANCES PRE-CONSTRUCTION PLAN	LSUM	1	1	
* 66901000	BACKFILL PLUGS	CU YD	154	154	①

* SPECIALTY ITEM

① REVISED SHEET 5/25/2021

REV-SEP



USER NAME = khejtmanek	DESIGNED - KH	REVISED -
DRAWN - KM	REVISIONS -	
PLOT SCALE = 2.0000' / in.	CHECKED - AP	REVISED -
PLOT DATE = 3/10/2021	DATE - 3/11/2021	REVISED -

STATE OF ILLINOIS
DEPARTMENT OF TRANSPORTATION

SUMMARY OF QUANTITIES			
SCALE: NONE	SHEET 4	OF 6 SHEETS	STA. TO STA.

F.A.P. RTE. 344	SECTION 2020-196-T	COUNTY	TOTAL SHEETS 122	SHEET NO. 7
CONTRACT NO. 62M69			ILLINOIS FED. AID PROJECT	

CODE NO.	ITEM	UNIT	TOTAL QUANTITY URBAN	CONSTRUCTION CODE	
				80% FED, 20% STATE	80% FED, 20% STATE
				BRIDGE 0004 SN: 022-8300	RETAINING WALL 0044 SN: 022-W001
* 66901003	REGULATED SUBSTANCES FINAL CONSTRUCTION REPORT	LSUM	1	1	
* 66901006	REGULATED SUBSTANCES MONITORING	CAL DA	35	30	5
67000400	ENGINEER'S FIELD OFFICE, TYPE A	CAL MO	12	12	
67100100	MOBILIZATION	L SUM	1	1	
70103815	TRAFFIC CONTROL SURVEILLANCE	CAL DA	133	133	
70107005	PAVEMENT MARKING BLACKOUT TAPE, 5"	FOOT	4,760	4,760	
70107009	PAVEMENT MARKING BLACKOUT TAPE, 9"	FOOT	185	185	
70200100	NIGHTTIME WORK ZONE LIGHTING	L SUM	1	1	
70300150	SHORT TERM PAVEMENT MARKING REMOVAL	SQ FT	1,696	1,696	
70300904	PAVEMENT MARKING TAPE, TYPE IV 4"	FOOT	22,558	22,558	
70300908	PAVEMENT MARKING TAPE, TYPE IV 8"	FOOT	11,486	11,486	
70400100	TEMPORARY CONCRETE BARRIER	FOOT	3,475	3,475	
70400200	RELOCATE TEMPORARY CONCRETE BARRIER	FOOT	3,788	3,788	
70600260	IMPACT ATTENUATORS, TEMPORARY (FULLY REDIRECTIVE, NARROW), TEST LEVEL 3	EACH	4	4	
70600270	IMPACT ATTENUATORS, TEMPORARY (FULLY REDIRECTIVE, WIDE), TEST LEVEL 3	EACH	1	1	

* SPECIALTY ITEM

1 REVISED SHEET 5/25/2021

REV-SEP

MODEL: D:\p1\11\1100000000 - IDOT\1100000000 - ENG - PTB - 195-016 Phase II Vpr Vpr\Engineering\WO - 1 - 110241381500 Drawings\502 CADD Sheets\110241381500-110241381500.dgn



USER NAME = khejtmanek	DESIGNED - KH	REVISED -
DRAWN - KM	CHECKED - AP	REVISED -
PLOT SCALE = 2.0000' / in.	DATE - 3/11/2021	REVISED -
PLOT DATE = 3/10/2021		

STATE OF ILLINOIS
DEPARTMENT OF TRANSPORTATION

SUMMARY OF QUANTITIES

SCALE: NONE SHEET 5 OF 6 SHEETS STA. TO STA.

F.A.P. RTE.	SECTION	COUNTY	TOTAL SHEETS	SHEET NO.
344	2020-196-T	DUPAGE	122	8
CONTRACT NO. 62M69			ILLINOIS FED. AID PROJECT	

HOT-MIX ASPHALT MIXTURE REQUIREMENTS		QMP
MIXTURE TYPE	AIR VOIDS @ NDES	
PAVEMENT RECONSTRUCTION		
POLYMERIZED HOT-MIX ASPHALT SURFACE COURSE, SMA, 9.5, MIX "F", N80 (1 3/4")	3.5% @ 80 GYR	QC/QA
POLYMERIZED HOT-MIX ASPHALT BINDER COURSE, IL-19.0, N90 (2 1/4")	4.0% @ 90 GYR	QC/QA
HMA SHOULDER		
POLYMERIZED HOT-MIX ASPHALT SURFACE COURSE, SMA, 9.5, MIX "F", N80 (1 3/4")	3.5% @ 80 GYR	QC/QA
HOT-MIX ASPHALT BINDER COURSE, IL-19.0, N90 (10 1/4")	4.0% @ 90 GYR	QC/QA
TEMPORARY PAVEMENT (11")		
HOT-MIX ASPHALT SURFACE COURSE, IL-9.5, MIX "D", N70 (2")	4.0% @ 70 GYR	QC/QA
HOT-MIX ASPHALT BINDER COURSE, IL-19.0, N70 (9")	4.0% @ 70 GYR	QC/QA

QMP DESIGNATIONS: QUALITY CONTROL/QUALITY ASSURANCE (QC/QA)

NOTES:

1. THE UNIT WEIGHT USED TO CALCULATE ALL HMA SURFACE MIXTURE QUANTITIES IS 112 LBS/SQ YD/IN.
2. THE "AC TYPE" FOR POLYMERIZED HMA MIXES SHALL BE "SBS/SBR PG-76-22" AND FOR NON-POLYMERIZED HMA THE "AC TYPE" SHALL BE "PG 64-22" UNLESS MODIFIED BY SPECIAL PROVISIONS.
3. FOR USE OF RECYCLED MATERIALS SEE SPECIAL PROVISIONS.
4. QUALITY MANAGEMENT PROGRAM (QMP) IDENTIFIES THE PARTICULAR QUALITY CONTROL SPECIFICATION THAT APPLIES TO THE HMA MIXTURE.
5. PC CONCRETE TEMPORARY PAVEMENT SHALL CONSIST OF CLASS PV CONCRETE MEETING THE REQUIREMENTS OF ART. 1020 OF THE STANDARD SPECIFICATIONS. TEMPORARY PCC PAVEMENT DOES NOT REQUIRE DOWEL BARS.

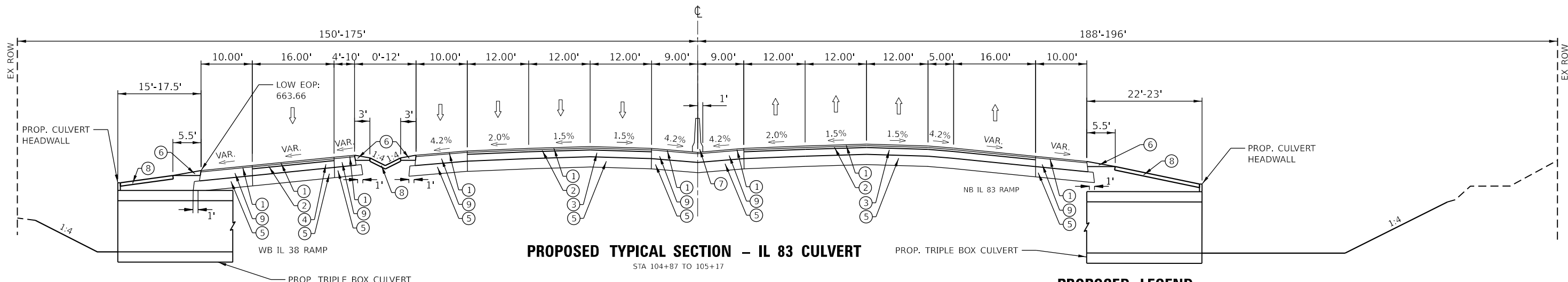

PROPOSED LEGEND

- ① POLYMERIZED HMA SURFACE COURSE, STONE MATRIX ASPHALT, 9.5, MIX "F", N80, 1 3/4"
- ② POLYMERIZED HMA BINDER COURSE IL-19.0, N90, 2 1/4"
- ③ CLASS A PAVEMENT PATCH (IL-83) - 8" CRC
- ④ CLASS B PAVEMENT PATCH (IL-83 SB RAMP) - 8" PCC
- ⑤ AGGREGATE SUBGRADE IMPROVEMENT, 12"
- ⑥ AGGREGATE SHOULDERS, TYPE B, 6"
- ⑦ CONCRETE BARRIER
- ⑧ TOPSOIL EXCAVATION AND PLACEMENT, 4"
- ⑨ HMA BINDER COURSE IL-19.0, N90, 10 1/4"



REVISIED SHEET 5/25/2021

MODEL: D:\p\h\...
 FILE NAME: P:\00058...
 MODEL: D:\p\h\...
 FILE NAME: P:\00058...
 IDOT\00058\01\002 (ENG) - PTB 195-016 Phase II Var Var\Engineering\WO 01 - IL83\IL83\500 Drawings\502 CADD Sheets\0162M69-sheet-by-drc002.dgn



USER NAME = khejtmanek	DESIGNED - KH	REVISED - 5-14-2021
DRAWN - KM	REVISIED -	
PLOT SCALE = 20.0000' / in.	CHECKED - AP	REVISIED -
PLOT DATE = 3/10/2021	DATE - 3/11/2021	REVISIED -

STATE OF ILLINOIS
DEPARTMENT OF TRANSPORTATION

TYPICAL SECTIONS		IL 83	
SCALE: NONE	SHEET 2	OF 3 SHEETS	STA. TO STA.

F.A.P. RTE.	SECTION	COUNTY	TOTAL SHEETS	SHEET NO.
344	2020-196-T	DUPAGE	122	14
CONTRACT NO. 62M69			ILLINOIS FED. AID PROJECT	