

TYPICAL EQUIPMENT RACK CROSS SECTION
NOT TO SCALE

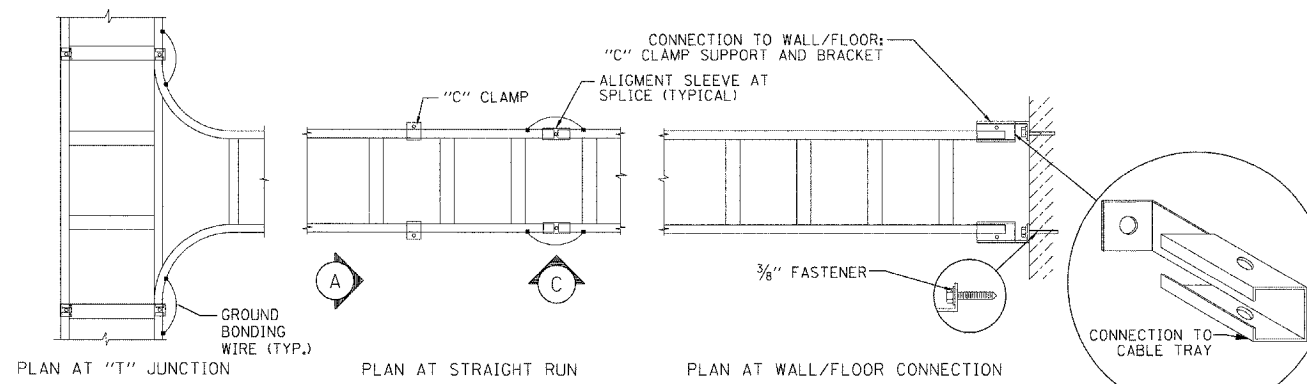

CABLE TRAY- DETAILED PLAN VIEW
NOT TO SCALE

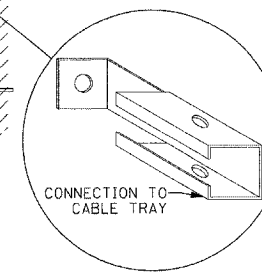

C-CLAMP BRACKET DETAIL

- NOTES:**
1. ALL BENDS IN THE INTERIOR GROUND WIRE SHALL BE 12-INCH NOMINAL AND 8-INCH MINIMUM.
 2. INSTALL INTERIOR GROUND BUS 7' 6" FROM THE FLOOR AND NOT CLOSER THAN 3" FROM THE CEILING UNLESS OTHERWISE DIRECTED BY THE ENGINEER.
 3. EACH SECTION OF INTERIOR CABLE TRAY SHALL BE BONDED TOGETHER USING TWO #6 AWG JUMPERS (ONE ON EACH SIDE) TO FORM AN ELECTRICALLY CONTINUOUS TRAY.
 4. ALL GROUNDING CONNECTIONS TO THE GROUND BUS AND EQUIPMENT SHALL BE MADE WITH DOUBLE HOLE HYDRAULICALLY INDENTED LUGS.

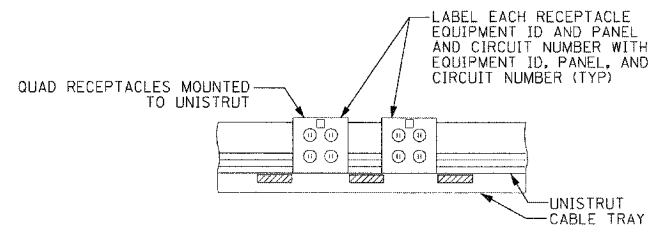

CABLE TRAY OUTLETS
NOT TO SCALE
(UPS RECEPTACLES TO BE ORANGE)

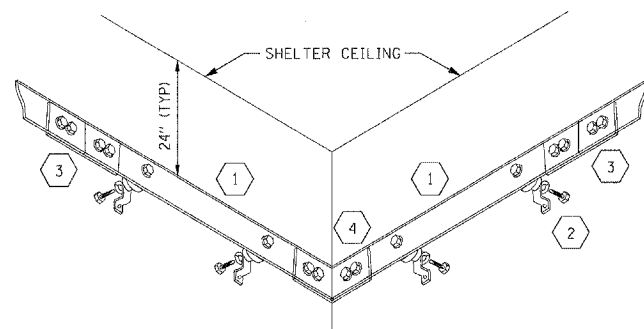

LEGEND

- 1 1/4" X 4" X (LENGTH) COPPER GROUND BAR
- 2 STAND-OFF INSULATORS, MOUNTING BRACKETS AND HARDWARE
- 3 2" X 6" SPLICE PLATE
- 4 (1/4" THICK) 2" WIDE -90 DEGREE ELBOW
- 5 STAINLESS STEEL MOUNTING BRACKET
- 6 3/4" HEX HEAD CAP SCREW (2 PER MOUNT)
- 7 LOCK WASHER AND FLAT WASHER (2 PER MOUNT)
- 8 2" X 2" STAND-OFF INSULATOR

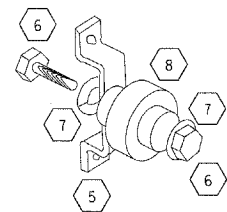

GROUND BUS SYSTEM
NOT TO SCALE

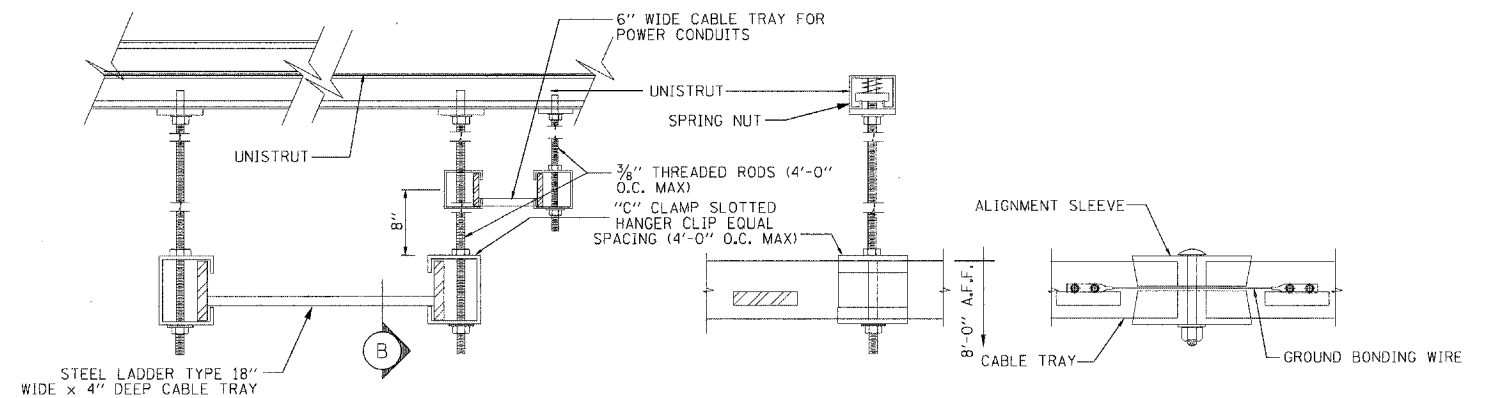

(A) SECTION THROUGH CABLE TRAY
NOT TO SCALE

(B) SECTION AT "C" CLAMP
NOT TO SCALE

(C) ELEVATION AT SPLICE
NOT TO SCALE

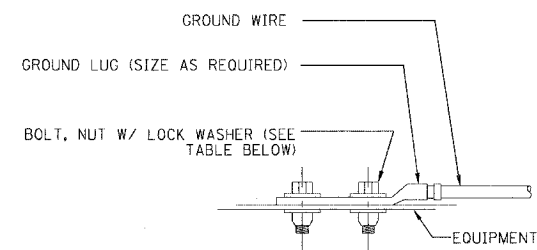

TYPICAL EQUIPMENT GROUND CONNECTION
NOT TO SCALE

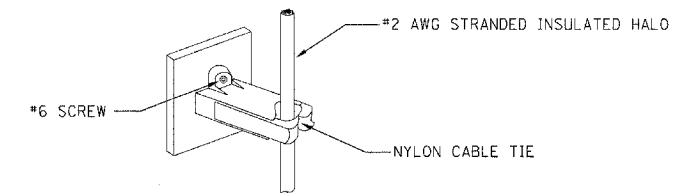

GROUND WIRE STANDOFF DETAIL
NOT TO SCALE

WIRE SIZE	LUG #	BOLT SIZE
#4/0	53212	1/2" - 20 NC x 1/2" S.S. BOLT & NUT W/LOCK WASHERS
#2	53207	1/4" - 20 NC x 1/2" S.S. BOLT & NUT W/LOCK WASHERS
#6	53205	