

★ 49+1 = 50

F.A.P. RTE.	SECTION	COUNTY	TOTAL SHEETS	SHEET NO.
I57	2008-082L	COOK & WILL	49	1
FED. ROAD DIST. NO.	ILLINOIS	CONTRACT NO. 60F84		

C-91-245-09
CONTRACT NO. 60F84

FOR INDEX OF SHEETS, SEE SHEET NO. 2

STATE OF ILLINOIS
DEPARTMENT OF TRANSPORTATION
DIVISION OF HIGHWAYS

**PROPOSED
HIGHWAY PLANS**

FAI ROUTE I57
Section No.: 2008-082 L

U.S. 30 INTERCHANGE TO
REST AREAS SOUTH OF PAULING ROAD
CONTINUOUS ROADWAY LIGHTING

Project No.: HSIP-057-7(284)333
COOK & WILL COUNTY
C-91-245-09



PROJECT LOCATED IN THE
VILLAGES OF MATTESON AND
RICHTON PARK, RICH TOWNSHIP,
VILLAGE OF UNIVERSITY PARK
AND MONEE TOWNSHIP

TRAFFIC DATA
POSTED SPEED: 65 MPH

DESIGN DESIGNATION
INTERSTATE

STATE STANDARDS

STD NO.	TITLE
701001-02	OFF ROAD OPERATIONS, 2L, 2W, MORE THAN 4.5M (15') AWAY
701006-03	OFF-ROAD OPERATIONS, 2L, 2W, 4.5M (15') TO 600MM (24") FROM PAVEMENT EDGE
701400-03	APPROACH TO LANE CLOSURE, FREEWAY/EXPRESSWAY
701401-05	LANE CLOSURE, FREEWAY/EXPRESSWAY
701411-05	LANE CLOSURE, MULTILANE, AT ENTRANCE OR EXIT RAMP, FOR SPEEDS ≥ 45 MPH
701901-01	TRAFFIC CONTROL DEVICES

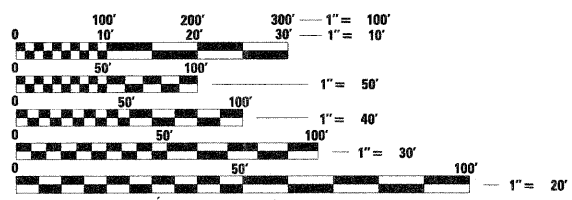

FULL SIZE PLANS HAVE BEEN PREPARED USING STANDARD ENGINEERING SCALES. REDUCED SIZED PLANS WILL NOT CONFORM TO STANDARD SCALES. IN MAKING MEASUREMENTS ON REDUCED PLANS, THE ABOVE SCALES MAY BE USED.

J.U.L.I.E.
JOINT UTILITY LOCATION INFORMATION FOR EXCAVATION
1-800-892-0123
OR 811

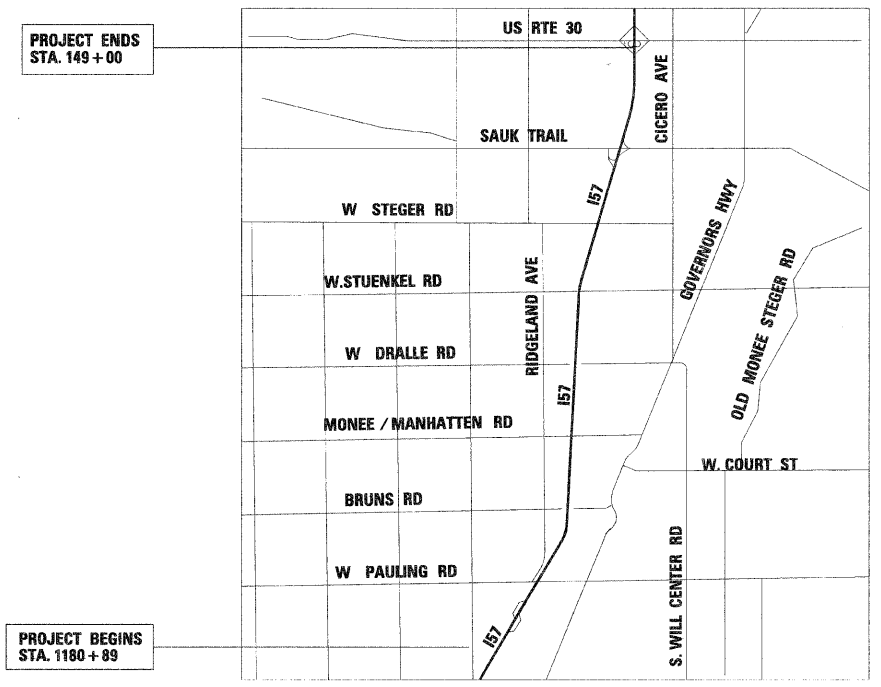

LOCATION MAP

SCALE: 1" = 5000'

PROJECT GROSS AND NET LENGTH (U.S. INTERSTATE I57) = 44,240 FT (8.38 MILES)



David E. Mertz
8 APRIL 2009
DAVID E. MERTZ, P.E. ENGINEER
ILLINOIS REGISTRATION No. 062-052068
EXPIRATION DATE: 11/30/2009

STATE OF ILLINOIS
DEPARTMENT OF TRANSPORTATION
DIVISION OF HIGHWAYS

SUBMITTED APRIL 10, 2009

Devin M. O'Keefe
DEPUTY DIRECTOR OF HIGHWAYS, REGION ONE ENGINEER

May 8, 2009
Charles G. Ingersoll
ENGINEER OF DESIGN AND ENVIRONMENT

May 8, 2009
Christine M. Reed
DIRECTOR OF HIGHWAYS, CHIEF ENGINEER

PRINTED BY THE AUTHORITY
OF THE STATE OF ILLINOIS

CONTRACT NO. 60F84

IDOT PROJECT MANAGER -- BRIAN KUTTAB (847) 705-4431 (DISTRICT 1)

90% FED. / 10% STATE

CODE NO.	ITEM	UNIT	QUANTITIES		
			Y030-1E TOTAL QUANTITY	Y030-1E WILL	Y030-1E COOK
6700040C	ENGINEER'S FIELD OFFICE TYPE A	CAL MO	5	3.75	1.25
67100100	MOBILIZATION	L SUM	1.00	0.75	0.25
80400100	ELECTRIC SERVICE INSTALLATION	EACH	6	4	2
80400200	ELECTRIC UTILITY SERVICE CONNECTION	L SUM	1.00	0.75	0.25
81300420	JUNCTION BOX, STAINLESS STEEL, ATTACHED TO STRUCTURE, 10" X 8" X 6"	EACH	4	0	4
81700125	ELECTRIC CABLE IN CONDUIT, 600V (EPR-TYPE RHW) 1/C NO. 4	FOOT	330	0	330
81700130	ELECTRIC CABLE IN CONDUIT, 600V (EPR-TYPE RHW) 1/C NO. 2	FOOT	990	0	990
81701385	ELECTRIC CABLE IN CONDUIT, 600V (EPR-TYPE USE) 3-1/C 350 MCM	FOOT	1290	940	350
8190C200	TRENCH AND BACKFILL FOR ELECTRICAL WORK	FOOT	1150	840	310
82102310	LUMINAIRE, SODIUM VAPOR, HORIZONTAL MOUNT, 310 WATT	EACH	353	269	84
82105700	LUMINAIRE, SODIUM VAPOR, HIGH MAST, HORIZONTAL MOUNT, 750 WATT	EACH	8	0	8
83011600	LIGHT POLE, ALUMINUM, 55 FT. M.H., 15 FT. MAST ARM	EACH	4	4	0
83050810	LIGHT POLE, ALUMINUM, 47.5 FT. M.H., 15 FT. MAST ARM	EACH	353	269	84
83700250	LIGHT TOWER FOUNDATION, 44" DIAMETER	FOOT	80	0	80
83800205	BREAKAWAY DEVICE, TRANSFORMER BASE, 15 INCH BOLT CIRCLE	EACH	357	273	84
84200500	REMOVAL OF EXISTING LIGHTING UNIT, SALVAGE	EACH	10	8	2
84200700	LIGHTING FOUNDATION REMOVAL	EACH	10	8	2
84500110	REMOVAL OF LIGHTING CONTROLLER	EACH	1	0	1
84500130	REMOVAL OF LIGHTING CONTROLLER FOUNDATION	EACH	1	0	1
X0323574	MAINTENANCE OF LIGHTING SYSTEM	CAL MO	5	3.75	1.25
X0325702	NIGHT TIME WORK ZONE LIGHTING	L SUM	1.00	0.75	0.25
X7011015	TRAFFIC CONTROL AND PROTECTION (EXPRESSWAYS)	L SUM	1.00	0.75	0.25
X8160395	UNIT DUCT, WITH 3-1/C NO. 2 AND 1/C NO. 4 GROUND, 600 (EPR-TYPE RHW), 1 1/2" DIA., POLYETHYLENE	FOOT	84725	62800	21925
X8250110	LIGHTING CONTROLLER, RADIO CONTROL, DUPLEX CONSOLE TYPE, WITH SCADA	EACH	6	4	2
XX006937	GROUND ROD, 5/8" DIA. X 10 FT.	EACH	8	0	8
81100605	CONDUIT ATTACHED TO STRUCTURE, 2" DIA., GALVANIZED STEEL PVC COATED	FOOT	320	0	320
81101005	CONDUIT ATTACHED TO STRUCTURE, 4" DIA., GALVANIZED STEEL PVC COATED	FOOT	40	0	40
81001000	CONDUIT IN TRENCH, 4" DIA., GALVANIZED STEEL	FOOT	1150	840	310
81018900	CONDUIT PUSHED, 4" DIA., GALVANIZED STEEL	FOOT	2330	1620	710
X0326412	INSTALL UNDERGROUND RACEWAY - SPECIAL	FOOT	84725	62800	21925
X8360360	LIGHT POLE FOUNDATION METAL, 15" BOLT CIRCLE, 10" X 8"	EACH	357	273	84
X8350012	LIGHT TOWER, 100 FT. MOUNTING HEIGHT, LUMINAIRE MT.-12	EACH	2	0	2
X8210750	LUMINAIRE, SODIUM VAPOR, RECTILINEAR TYPE, 750 WATT	EACH	4	4	0
		HOUR	500	500	

© 2007600 TRAINEES

04080

FILE NAME =	USER NAME = *USER*	DESIGNED	REVISED -	STATE OF ILLINOIS DEPARTMENT OF TRANSPORTATION	SUMMARY OF QUANTITIES				F.A.I RTE.	SECTION	COUNTY	TOTAL SHEETS	SHEET NO.
FILEL		DRAWN -	REVISED -		SCALE:	SHEET NO.	OF	SHEETS	STA.	TO STA.	COOK/WILL	49	3
		PLOT SCALE = *SCALE*	CHECKED -								CONTRACT NO. 60F84		
		PLOT DATE = *DATE*	DATE -								ILLINOIS FED. AID PROJECT		

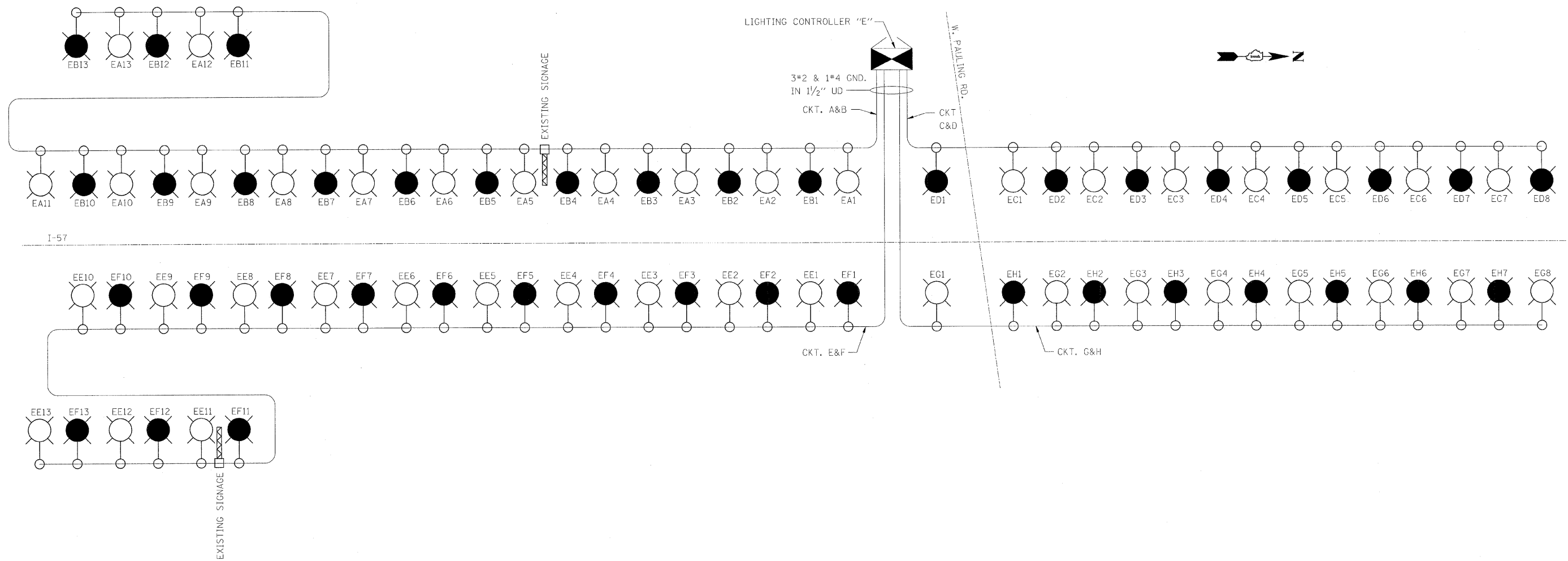

I-57

LOAD TABULATION FOR LIGHTING CONTROLLER "E"				
CIRCUIT	POLE NUMBER	PHASE 1 (RED) AMP	PHASE 2 (BLACK) AMP	BREAKER SIZE
A	1-13	19.5A		70A
B	1-13		19.5A	70A
C	1-7	10.5A		70A
D	1-8		12A	70A
E	1-13	19.5A		70A
F	1-13		19.5A	70A
G	1-8	12A		70A
H	1-7		10.5A	70A
SUB-TOTAL		61.5A	61.5A	
TOTAL		123A		

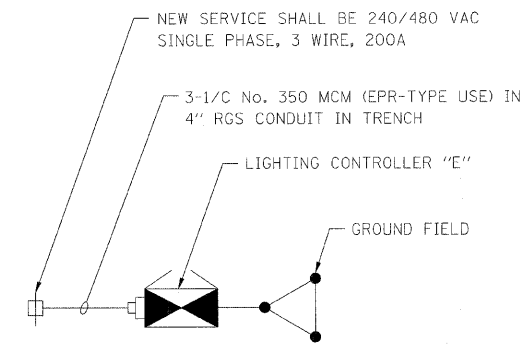

LEGEND:

- PROPOSED LIGHTING CONTROLLER
- LUMINAIRE DESIGNATION
PROPOSED 310W HPS LUMINAIRE ON 47.5 FT M.H. LIGHT POLE AND 15 FT MAST ARM (RED PHASE)
- LUMINAIRE DESIGNATION
PROPOSED 310W HPS LUMINAIRE ON 47.5 FT M.H. LIGHT POLE AND 15 FT MAST ARM (BLACK PHASE)
- UTILITY SERVICE POLE

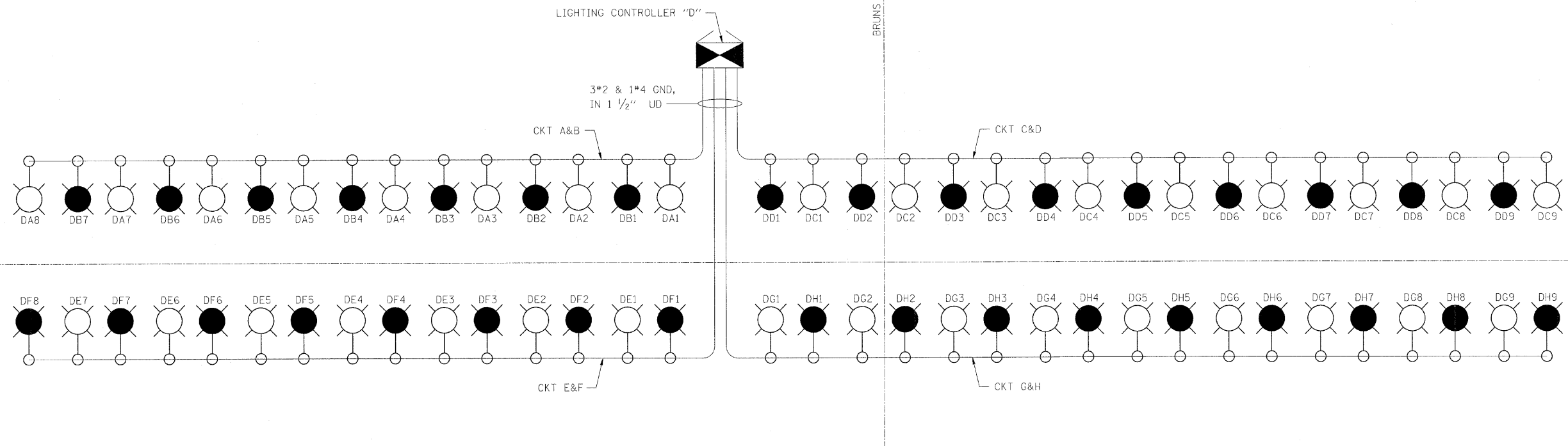

I-57

LOAD TABULATION FOR LIGHTING CONTROLLER "D"				
CIRCUIT	POLE NUMBER	PHASE 1 (RED) AMP	PHASE 2 (BLACK) AMP	BREAKER SIZE
A	1-8	12A		70A
B	1-7		10.5A	70A
C	1-9	13.5A		70A
D	1-9		13.5A	70A
E	1-7	10.5A		70A
F	1-8		12A	70A
G	1-9	13.5A		70A
H	1-9		13.5A	70A
SUB-TOTAL		49.5A	49.5A	
TOTAL		99A		

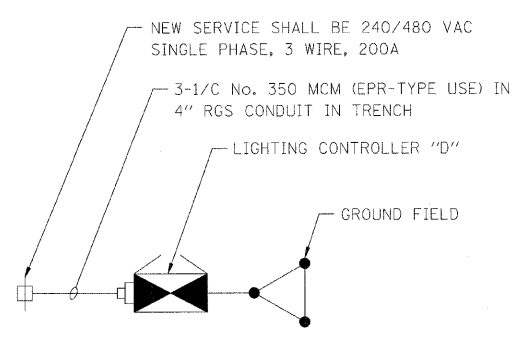

LEGEND:

- PROPOSED LIGHTING CONTROLLER
- LUMINAIRE DESIGNATION
PROPOSED 310W HPS LUMINAIRE ON 47.5 FT M.H. LIGHT POLE AND 15 FT MAST ARM (RED PHASE)
- LUMINAIRE DESIGNATION
PROPOSED 310W HPS LUMINAIRE ON 47.5 FT M.H. LIGHT POLE AND 15 FT MAST ARM (BLACK PHASE)
- UTILITY SERVICE POLE

F.A. RTE.	SECTION	COUNTY	TOTAL SHEETS	SHEET NO.
57	991(2) B-343-10-100-2	WILL	303	134
STA.	TO STA.			
FED. ROAD DIST. NO.	ILLINOIS FED. AID PROJECT			

PROPOSED IDOT LIGHTING CONTROLLER 'M'					
DUPLIX TYPE, 1Ø, 3 WIRE, 240/480V					
CIRCUIT	BLACK PHASE		RED PHASE		
	AMPS	WATTS	AMPS	WATTS	
A	17.8	3120.0	B	17.8	3120.0
D	17.8	3120.0	C	17.8	3120.0
F	3.4	816.0	E	3.4	816.0
G	8.5	2040.0	H	6.8	1632.0
J	11.9	2856.0	I	11.9	2856.0
K	5.1	1224.0	L	5.1	1224.0
N	6.8	1632.0	M	8.5	2040.0
P	11.9	2448.0	O	13.6	3264.0
TOTAL	83.2	19968.0	TOTAL	84.9	20376.0

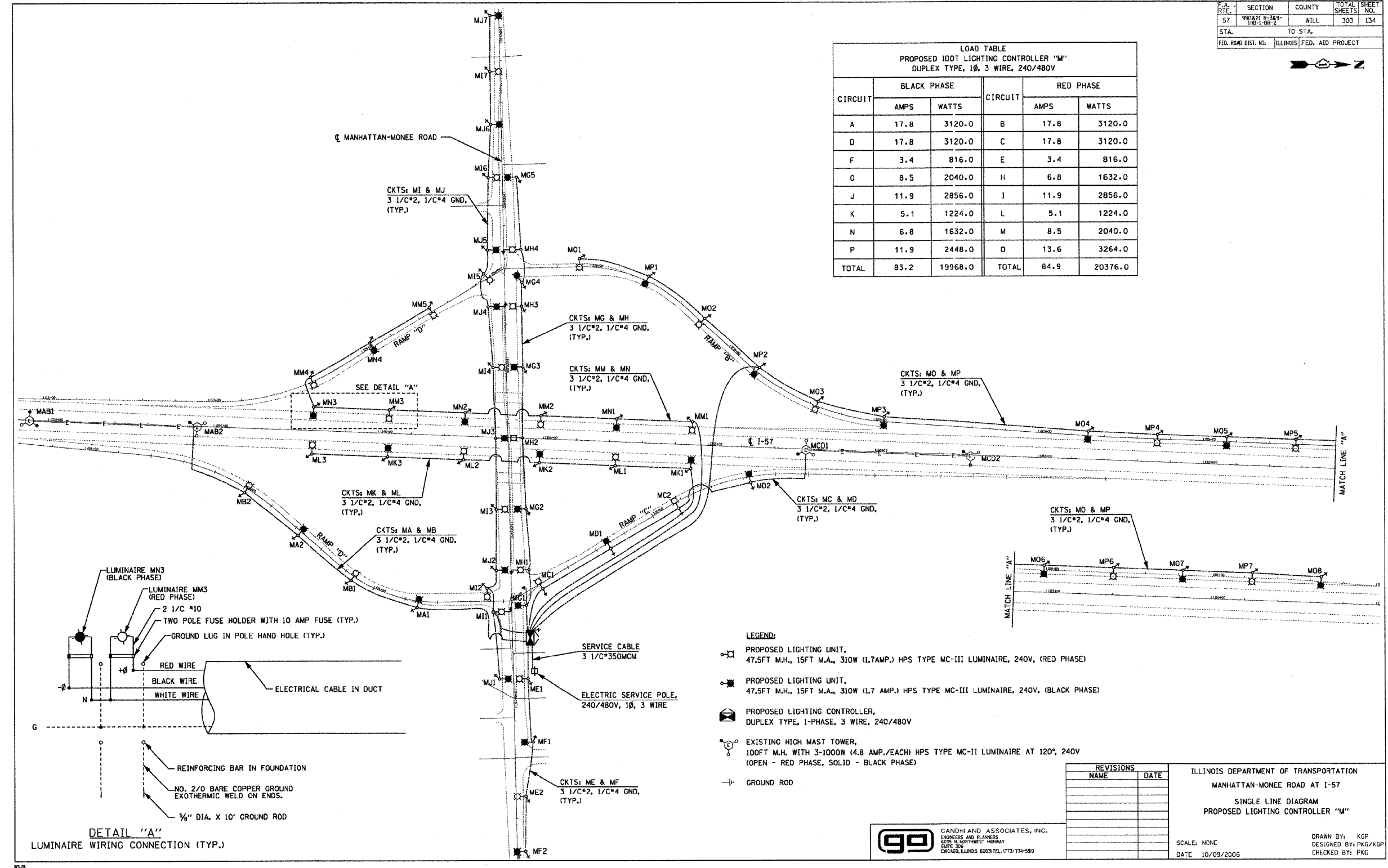

DETAIL "A"
LUMINAIRE WIRING CONNECTION (TYP.)

REVISIONS	
NAME	DATE

ILLINOIS DEPARTMENT OF TRANSPORTATION
 MANHATTAN-MONEE ROAD AT I-57
 SINGLE LINE DIAGRAM
 PROPOSED LIGHTING CONTROLLER "M"
 SCALE: NONE
 DATE: 10/09/2006
 DRAWN BY: KGP
 DESIGNED BY: PKG/KGP
 CHECKED BY: PKG

GO GANDHI AND ASSOCIATES, INC.
 ENGINEERS AND PLANNERS
 6035 S. WOODSTOCK HIGHWAY
 SUITE 208
 CHICAGO, ILLINOIS 60639 TEL: (773) 774-9580

1507 PRO WIRING DIAGRAM.dwg 2/20/2008 4:07:14 PM

FOR REFERENCE ONLY. CONSTRUCTED UNDER CONTRACT 62253

FILE NAME =	USER NAME = #USER#	DESIGNED -	REVISED -	STATE OF ILLINOIS DEPARTMENT OF TRANSPORTATION	SINGLE LINE DIAGRAM, LIGHTING CONTROLLER M	F.A. RTE.	SECTION	COUNTY	TOTAL SHEETS	SHEET NO.	
#FILE#		DRAWN -	REVISED -			157	2008-082L	COOK/WILL	49	6	
		CHECKED -	REVISED -			CONTRACT NO. 60F84					
		DATE -	REVISED -			ILLINOIS FED. AID PROJECT					
PLOT SCALE = #SCALE#				SCALE:	SHEET NO. OF SHEETS	STA.	TO STA.				
PLOT DATE = #DATE#											

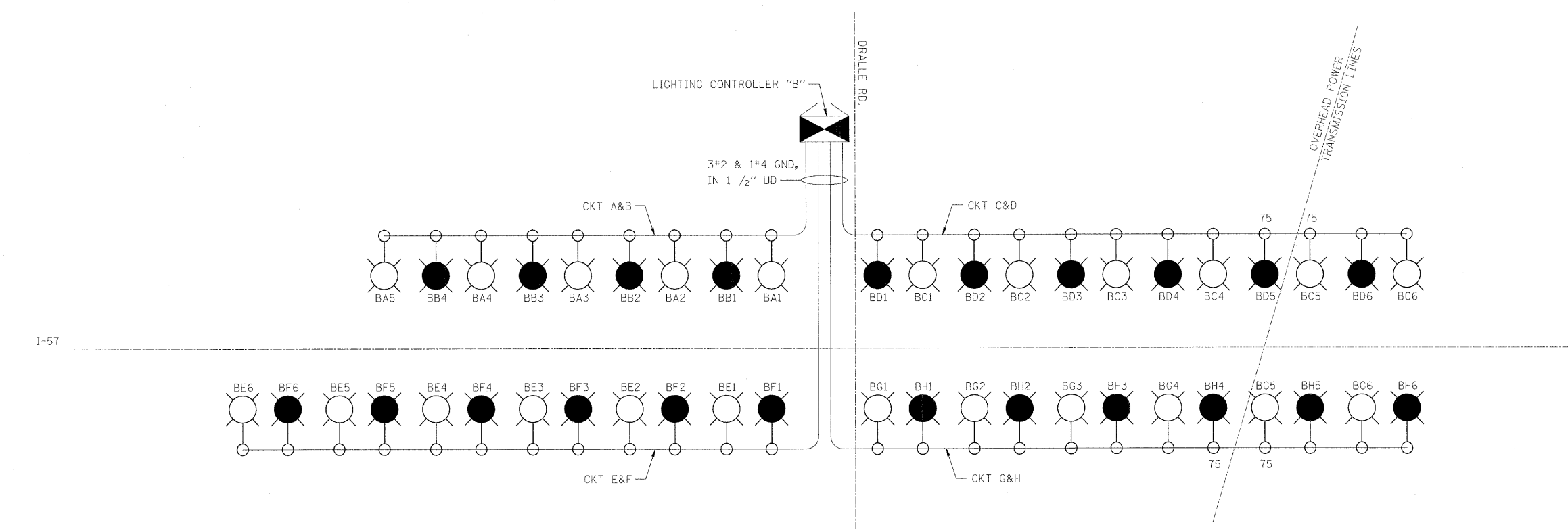

I-57

LOAD TABULATION FOR LIGHTING CONTROLLER "B"				
CIRCUIT	POLE NUMBER	PHASE 1 (RED) AMP	PHASE 2 (BLACK) AMP	BREAKER SIZE
A	1-5	7.5A		70A
B	1-4		6A	70A
C	1-6	11A		70A
D	1-6		11A	70A
E	1-6	9A		70A
F	1-6		9A	70A
G	1-6	11A		70A
H	1-6		11A	70A
SUB-TOTAL		38.5A	37A	
TOTAL		75.5A		

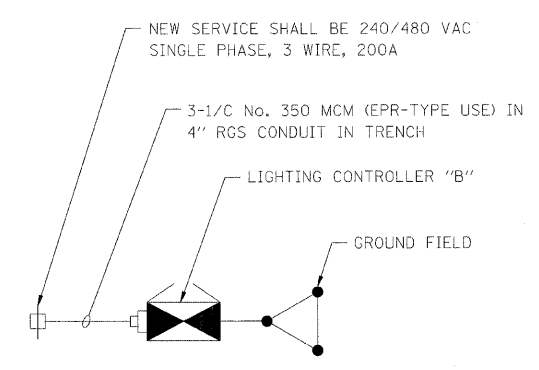

- LEGEND:**
- PROPOSED LIGHTING CONTROLLER
 - LUMINAIRE DESIGNATION
 - PROPOSED 310W HPS LUMINAIRE ON 47.5 FT M.H. LIGHT POLE AND 15 FT MAST ARM (RED PHASE)
 - LUMINAIRE DESIGNATION
 - PROPOSED 310W HPS LUMINAIRE ON 47.5 FT M.H. LIGHT POLE AND 15 FT MAST ARM (BLACK PHASE)
 - PROPOSED 750W HPS SHOE BOX LUMINAIRE ON 55 FT M.H. LIGHT POLE AND 15 FT MAST ARM
 - DENOTES 750W
 - UTILITY SERVICE POLE

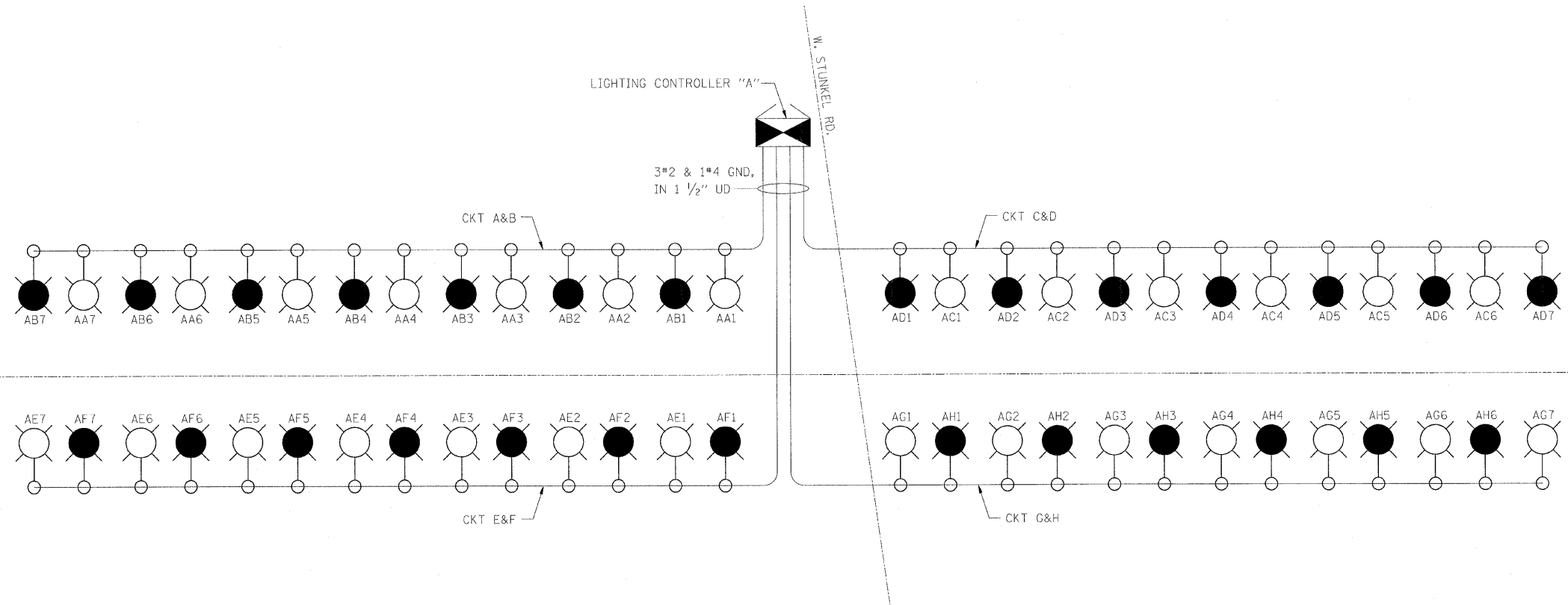





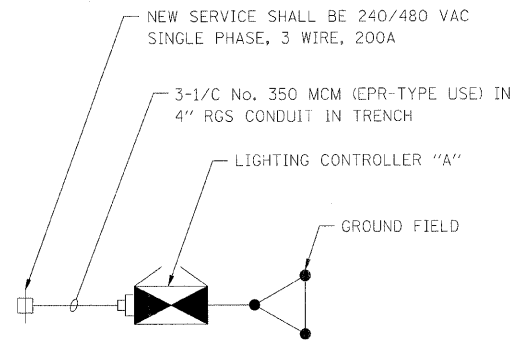

LOAD TABULATION FOR LIGHTING CONTROLLER "A"

CIRCUIT	POLE NUMBER	PHASE 1 (RED) AMP	PHASE 2 (BLACK) AMP	BREAKER SIZE
A	1-7	10.5A		70A
B	1-7		10.5A	70A
C	1-6	9A		70A
D	1-7		10.5A	70A
E	1-7	10.5A		70A
F	1-7		10.5A	70A
G	1-7	10.5A		70A
H	1-6		9A	70A
SUB-TOTAL		40.5A	40.5A	
TOTAL		81A		



LEGEND:

-  PROPOSED LIGHTING CONTROLLER
-  LUMINAIRE DESIGNATION
-  PROPOSED 310W HPS LUMINAIRE ON 47.5 FT M.H. LIGHT POLE AND 15 FT MAST ARM (RED PHASE)
-  LUMINAIRE DESIGNATION
-  PROPOSED 310W HPS LUMINAIRE ON 47.5 FT M.H. LIGHT POLE AND 15 FT MAST ARM (BLACK PHASE)
-  UTILITY SERVICE POLE

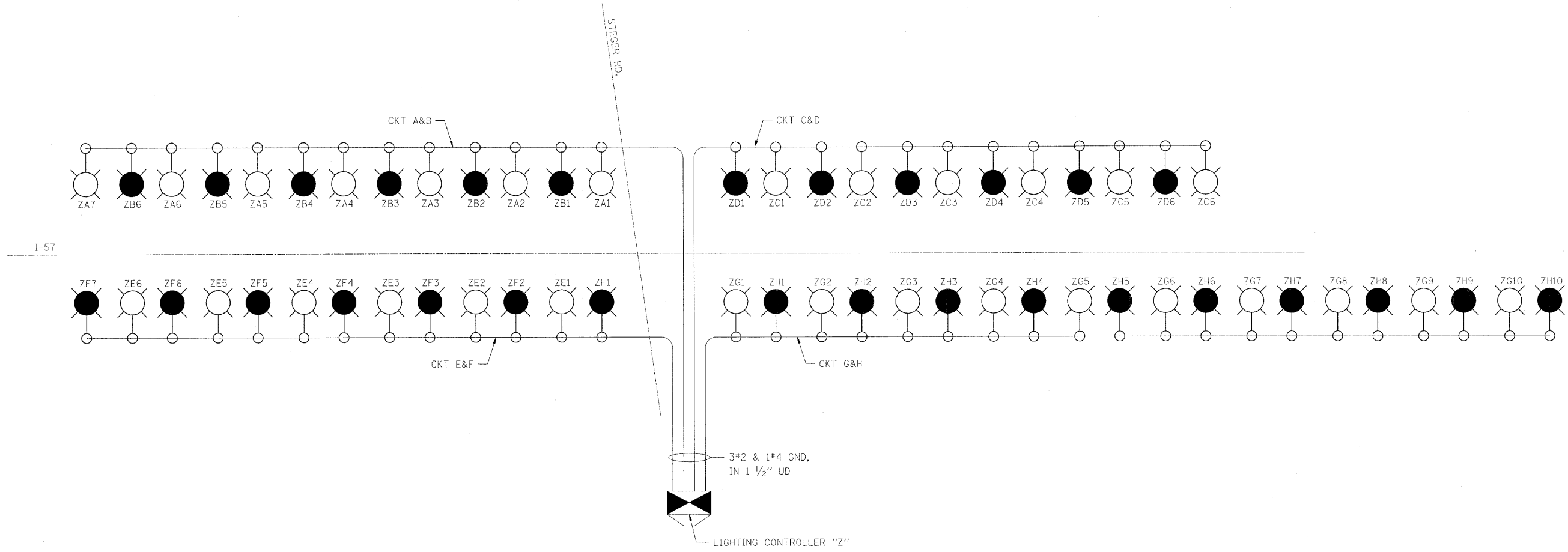





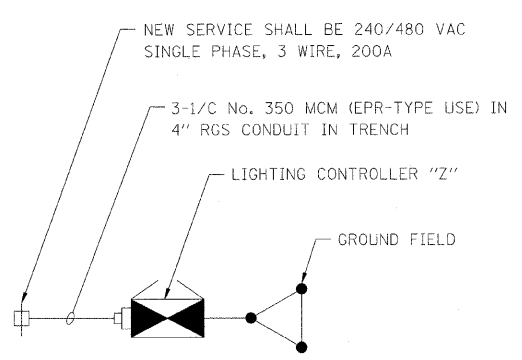

LOAD TABULATION FOR LIGHTING CONTROLLER "Z"

CIRCUIT	POLE NUMBER	PHASE 1 (RED) AMP	PHASE 2 (BLACK) AMP	BREAKER SIZE
A	1-7	10.5A		70A
B	1-6		9A	70A
C	1-6	9A		70A
D	1-6		9A	70A
E	1-6	9A		70A
F	1-7		10.5A	70A
G	1-10	15A		70A
H	1-10		15A	70A
SUB-TOTAL		43.5A	43.5A	
TOTAL		87A		



- LEGEND:**
- PROPOSED LIGHTING CONTROLLER
 - LUMINAIRE DESIGNATION
 - PROPOSED 310W HPS LUMINAIRE ON 47.5 FT M.H. LIGHT POLE AND 15 FT MAST ARM (RED PHASE)
 - LUMINAIRE DESIGNATION
 - PROPOSED 310W HPS LUMINAIRE ON 47.5 FT M.H. LIGHT POLE AND 15 FT MAST ARM (BLACK PHASE)
 - UTILITY SERVICE POLE

LEGEND:

-  EXISTING LIGHTING CONTROLLER "Y"
-  310 W. H.P.S. LUMINAIRE CONNECTED TO RED WIRE
-  310 W. H.P.S. LUMINAIRE CONNECTED TO BLACK WIRE
-  55 W. L.P.S. U.P. LUMINAIRE CONNECTED TO RED WIRE
-  55 W. L.P.S. U.P. LUMINAIRE CONNECTED TO BLACK WIRE
-  COM ED CO. SERVICE POLE
-  HIGH MAST LIGHT TOWER, 100 FT M.H.

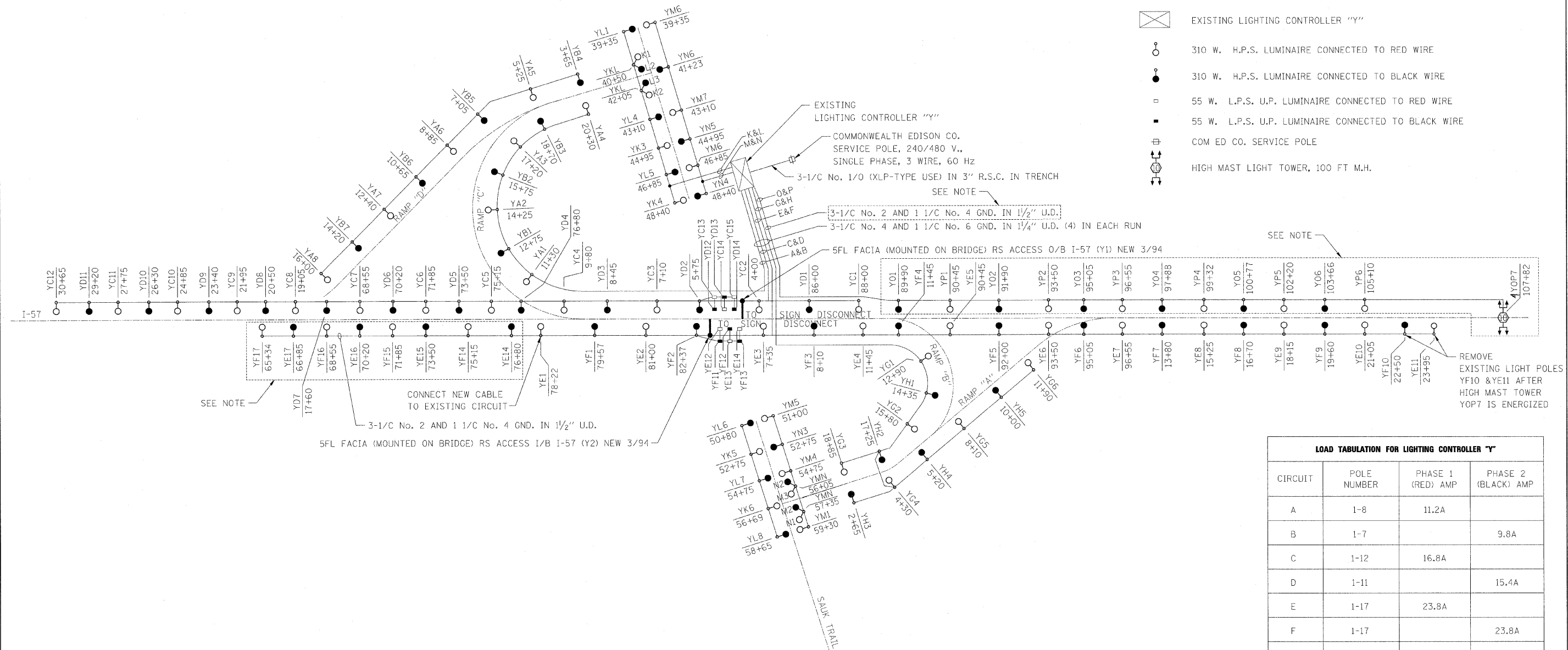

SEE NOTE

CONNECT NEW CABLE TO EXISTING CIRCUIT
 3-1/C No. 2 AND 1 1/C No. 4 GND. IN 1 1/2" U.D.
 5FL FACIA (MOUNTED ON BRIDGE) RS ACCESS I/B I-57 (Y2) NEW 3/94

EXISTING LIGHTING CONTROLLER "Y"
 COMMONWEALTH EDISON CO. SERVICE POLE, 240/480 V., SINGLE PHASE, 3 WIRE, 60 Hz
 3-1/C No. 1/0 (XLP-TYPE USE) IN 3" R.S.C. IN TRENCH
 SEE NOTE

3-1/C No. 2 AND 1 1/C No. 4 GND. IN 1 1/2" U.D.
 3-1/C No. 4 AND 1 1/C No. 6 GND. IN 1 1/4" U.D. (4) IN EACH RUN

SEE NOTE

REMOVE EXISTING LIGHT POLES YF10 & YE11 AFTER HIGH MAST TOWER YOP7 IS ENERGIZED

NOTE:

LIGHT POLES YE14 TO YE17, YF14 TO YF17, Y01 TO Y06, YP1 TO YP6, HIGH MAST LIGHT TOWER YOP7, AND THE UNIT DUCTS SERVING THEM ARE ALL PROPOSED. ALL OTHER EQUIPMENT AND CONDUCTORS SHOWN ARE EXISTING TO REMAIN UNLESS OTHERWISE NOTED.

LOAD TABULATION FOR LIGHTING CONTROLLER "Y"

CIRCUIT	POLE NUMBER	PHASE 1 (RED) AMP	PHASE 2 (BLACK) AMP
A	1-8	11.2A	
B	1-7		9.8A
C	1-12	16.8A	
D	1-11		15.4A
E	1-17	23.8A	
F	1-17		23.8A
G	1-6	8.4A	
H	1-5		7A
L	1-8	11.2A	
K	1-6		8.4A
M	1-6	8.4A	
N	1-6		8.4A
O	1-7	16.4A	
P	1-7		16.4A
SUB-TOTAL		96.2A	89.2A
TOTAL		185.4A	

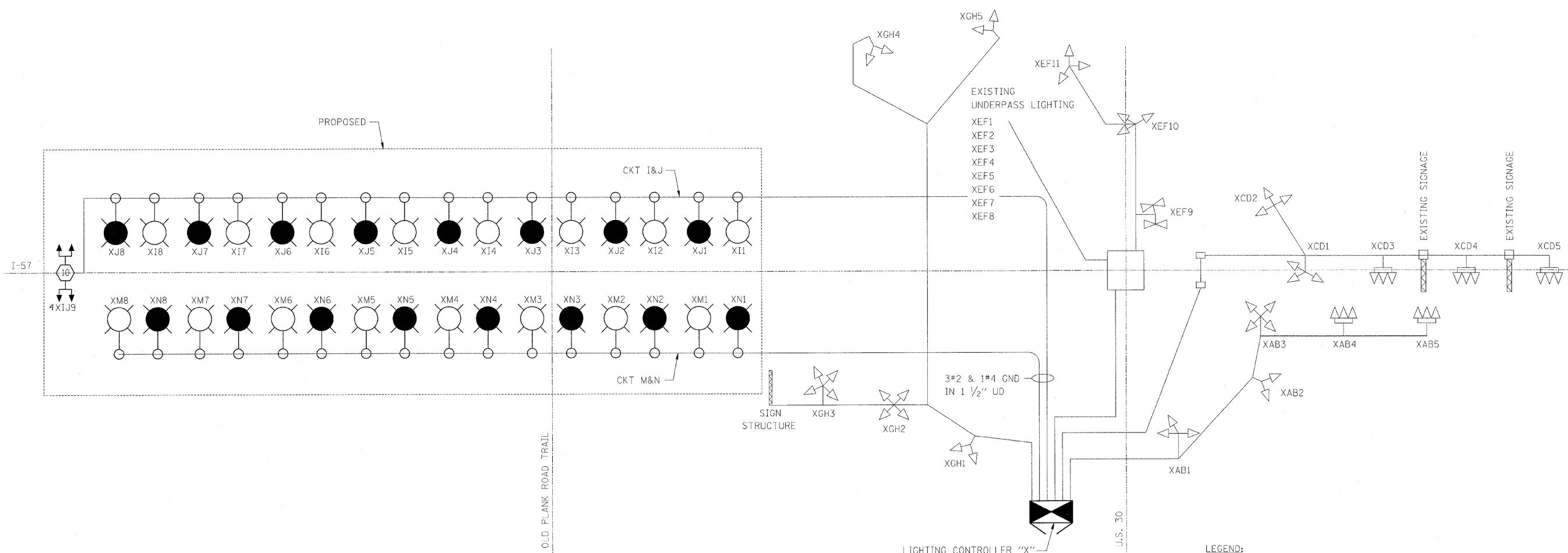

LOAD TABULATION FOR LIGHTING CONTROLLER "Z"

CIRCUIT	POLE NUMBER	PHASE 1 (RED) AMP	PHASE 2 (BLACK) AMP	BREAKER SIZE
I	1-9	15.5A		70A
J	1-9		15.5A	70A
M	1-8	12A		70A
N	1-8		12A	70A
SUB-TOTAL		27.5A	27.5A	
TOTAL		55A		

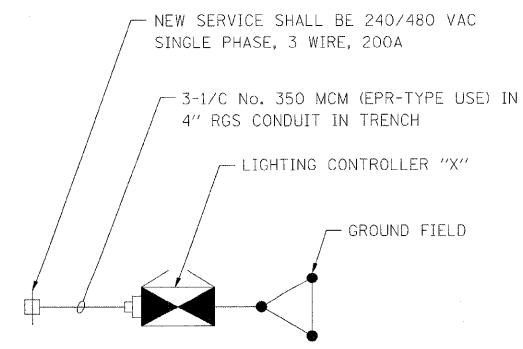

- LEGEND:**
- PROPOSED LIGHTING CONTROLLER
 - LUMINAIRE DESIGNATION
 - PROPOSED 310W HPS LUMINAIRE ON 47.5 FT. LIGHT POLE AND 15 FT. MAST ARM (RED PHASE)
 - LUMINAIRE DESIGNATION
 - PROPOSED 310W HPS LUMINAIRE ON 47.5 FT. LIGHT POLE AND 15 FT. MAST ARM (BLACK PHASE)
 - EXISTING HIGH MAST TOWER WITH LUMINAIRE
 - PROPOSED HIGH MAST LIGHT TOWER, 100 FT M.H.

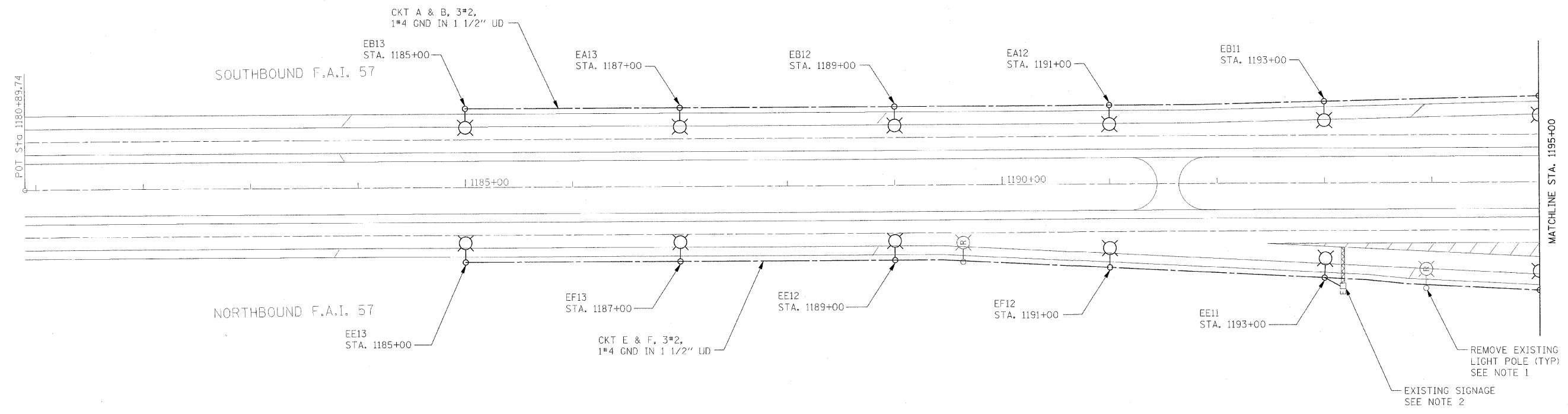
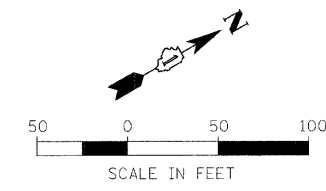

- NOTES:**
1. CONTRACTOR TO DETERMINE POWER SOURCE AND ISOLATE CKT BACK TO NEAREST SPLICE. EXISTING CABLE TO BE ABANDONED.
 2. RECONNECT EXISTING SIGNAGE TO NEW LIGHTING CIRCUIT.

FILE NAME = #FILE#	USER NAME = #USERS	DESIGNED -	REVISED -	STATE OF ILLINOIS DEPARTMENT OF TRANSPORTATION	I-57 PROPOSED LIGHTING PLAN, SOUTH LIMIT TO STA. 1195+00			F.A.I. RTE.	SECTION	COUNTY	TOTAL SHEETS	SHEET NO.
	PLOT SCALE = #SCALE#	DRAWN -	REVISED -					157	2008-082L	COOK/WILL	49	12
	PLOT DATE = #DATE#	CHECKED -	REVISED -		SCALE: 1"=50'-0" SHEET NO. OF SHEETS STA. 1180+89 TO STA. 1195+00			CONTRACT NO. 60F84				
		DATE -	REVISED -					ILLINOIS FED. AID PROJECT				

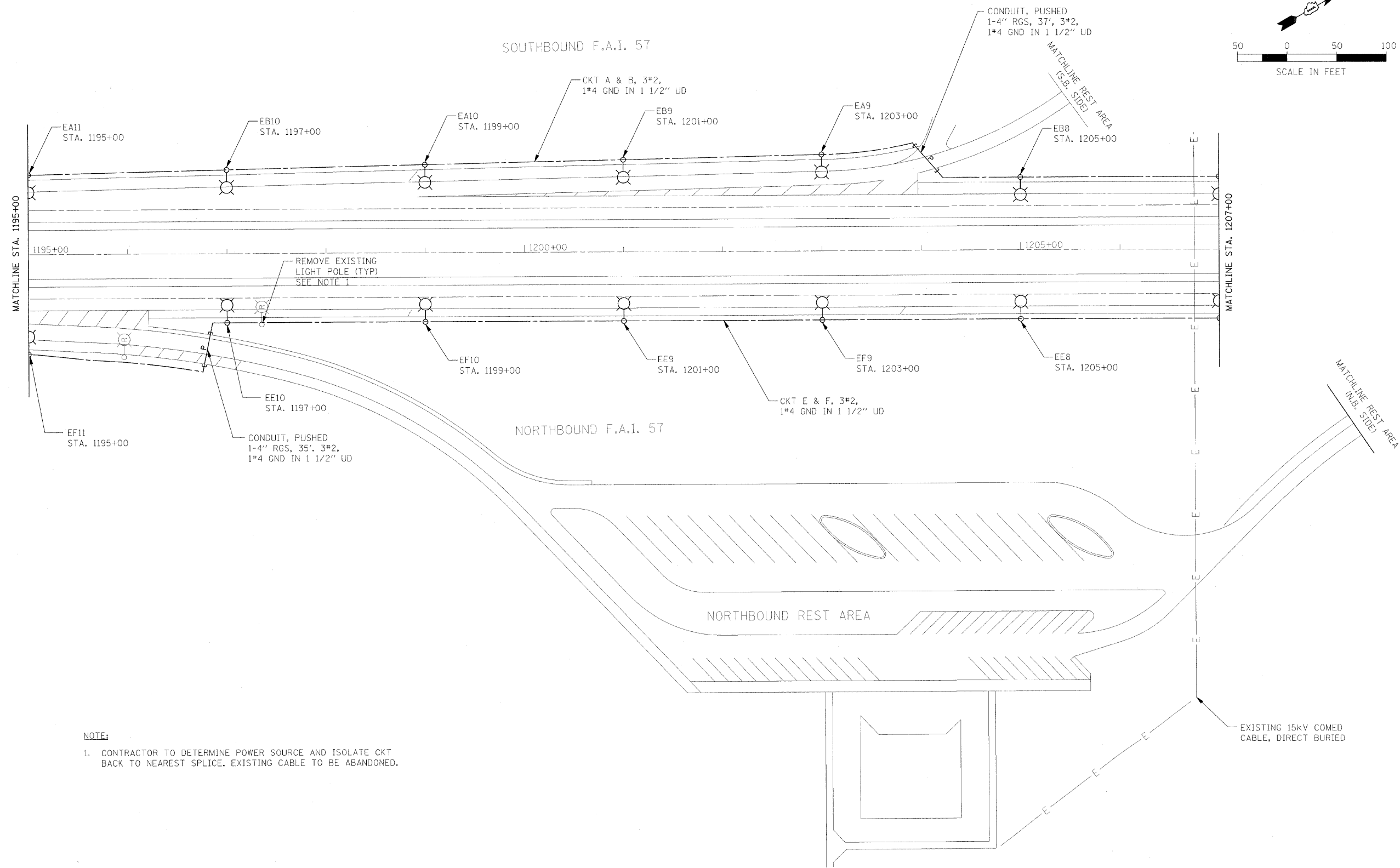

NOTE:
 1. CONTRACTOR TO DETERMINE POWER SOURCE AND ISOLATE CKT BACK TO NEAREST SPLICE. EXISTING CABLE TO BE ABANDONED.

FILE NAME = #FILE#	USER NAME = #USER#	DESIGNED -	REVISED -	STATE OF ILLINOIS DEPARTMENT OF TRANSPORTATION	I-57 PROPOSED LIGHTING PLAN, STA. 1195+00 TO 1207+00		F.A.I. RTE.	SECTION	COUNTY	TOTAL SHEETS	SHEET NO.
	PLOT SCALE = #SCALE#	DRAWN -	REVISED -				157	2008-082L	COOK/WILL	49	13
	PLOT DATE = #DATE#	CHECKED -	REVISED -				CONTRACT NO. 60F84				
				SCALE: 1"=50'-0"		SHEET NO. OF SHEETS STA. 1195+00 TO STA. 1207+00		ILLINOIS FED. AID PROJECT			

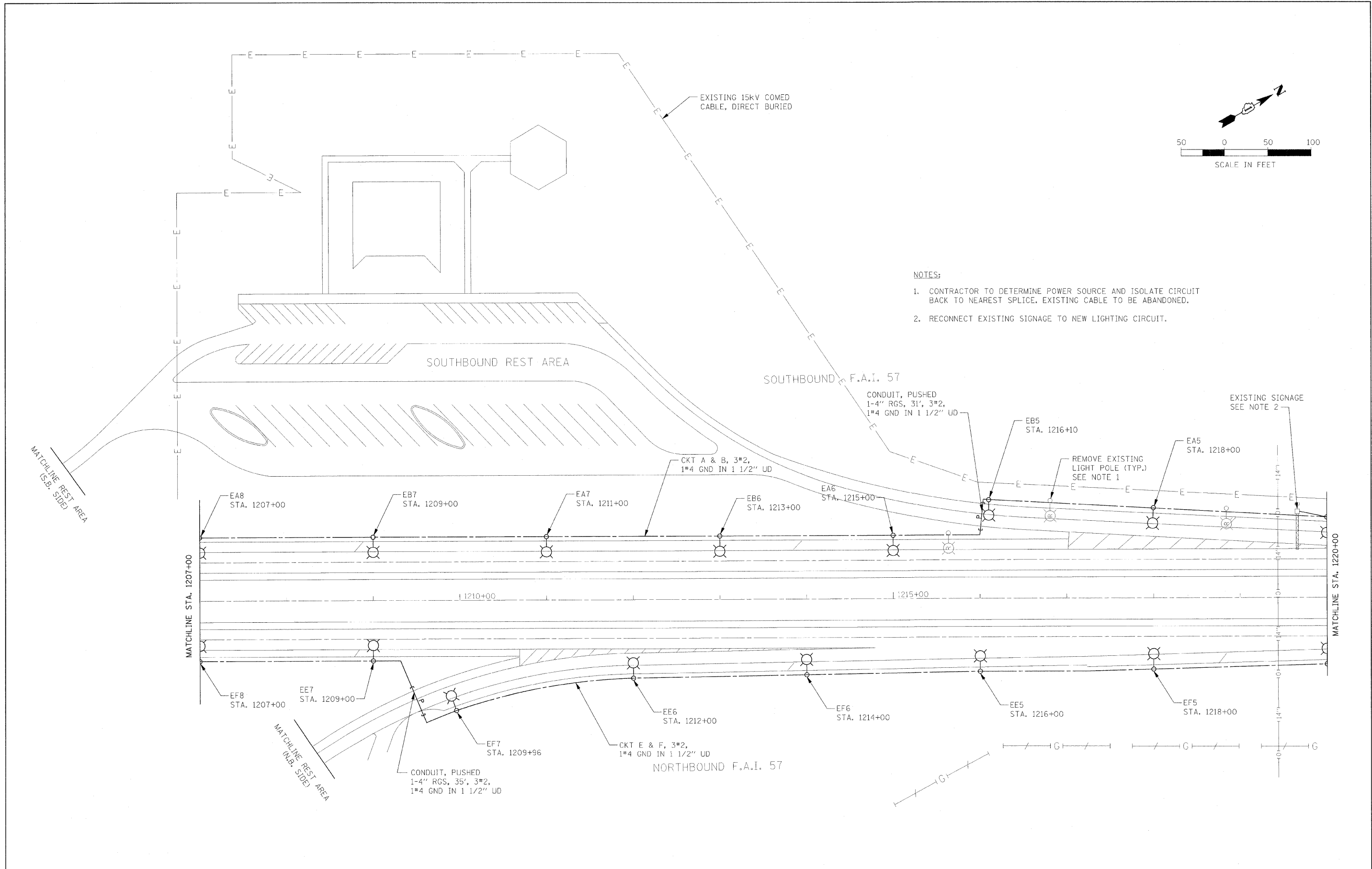

- NOTES:
1. CONTRACTOR TO DETERMINE POWER SOURCE AND ISOLATE CIRCUIT BACK TO NEAREST SPLICE. EXISTING CABLE TO BE ABANDONED.
 2. RECONNECT EXISTING SIGNAGE TO NEW LIGHTING CIRCUIT.

FILE NAME = #FILEL*	USER NAME = #USER*	DESIGNED -	REVISED -	STATE OF ILLINOIS DEPARTMENT OF TRANSPORTATION	I-57 PROPOSED LIGHTING PLAN, STA. 1207+00 TO 1220+00			F.A.I. RTE. 157	SECTION 2008-082L	COUNTY COOK/WILL	TOTAL SHEETS 49	SHEET NO. 14
	PLOT SCALE = #SCALE*	DRAWN -	REVISED -		SCALE: 1"=50'-0"	SHEET NO.	OF	SHEETS	STA. 1207+00	TO STA. 1220+00	CONTRACT NO. 60F84	
	PLOT DATE = #DATE*	CHECKED -	REVISED -		ILLINOIS FED. AID PROJECT							
		DATE -	REVISED -									

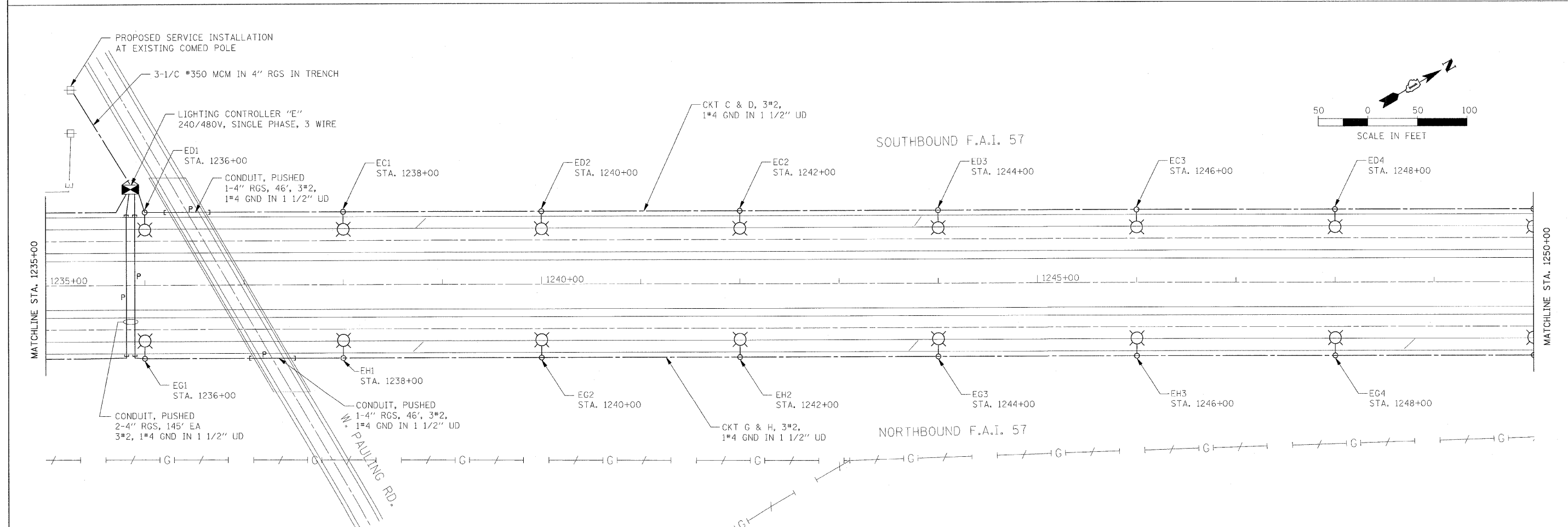
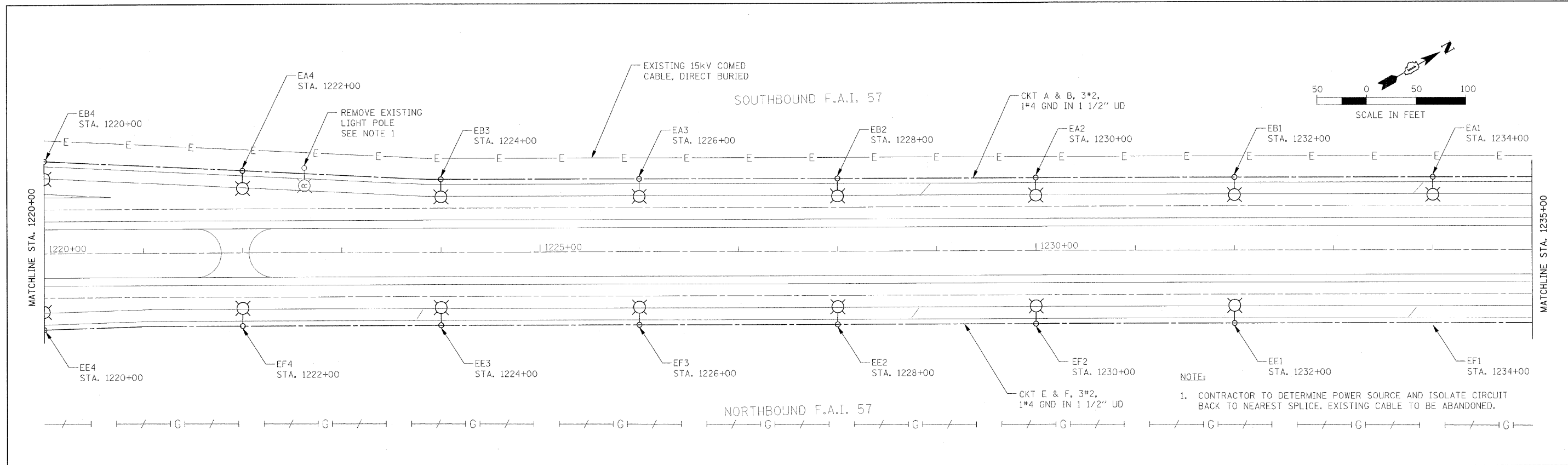

FILE NAME = #FILE#	USER NAME = #USER#	DESIGNED -	REVISIONS -	STATE OF ILLINOIS DEPARTMENT OF TRANSPORTATION	I-57 PROPOSED LIGHTING PLAN, STA. 1220+00 TO 1250+00			F.A.I. RTE. 157	SECTION 2008-082L	COUNTY COOK/WILL	TOTAL SHEETS 49	SHEET NO. 15
	PLOT SCALE = #SCALE#	DRAWN -	REVISIONS -					SCALE: 1"=50'-0"	SHEET NO. OF SHEETS	STA. 1220+00 TO STA. 1250+00	CONTRACT NO. 60F84	
	PLOT DATE = #DATE#	CHECKED -	REVISIONS -		ILLINOIS FED. AID PROJECT							
		DATE -	REVISIONS -									

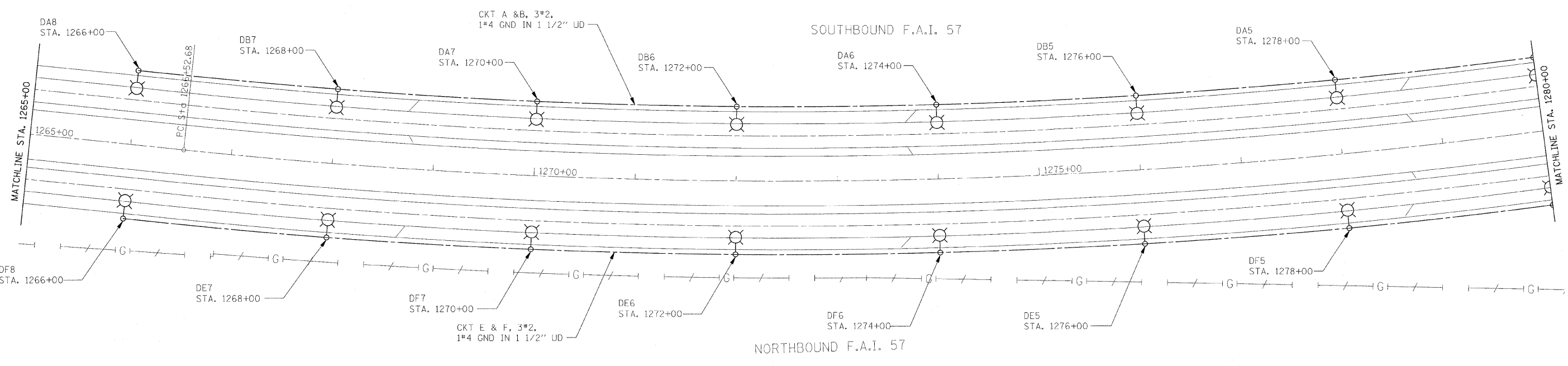
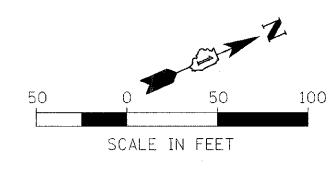
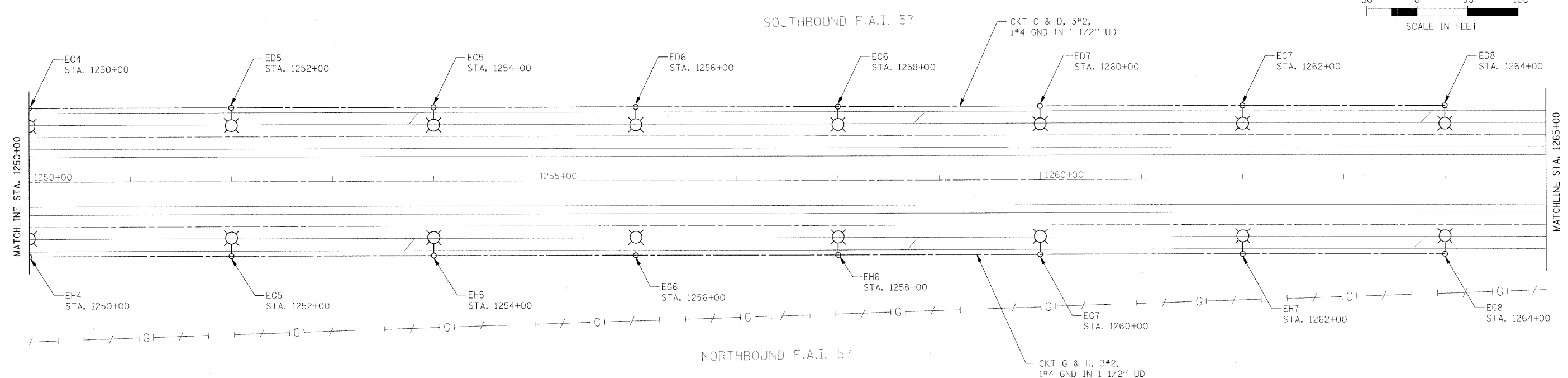
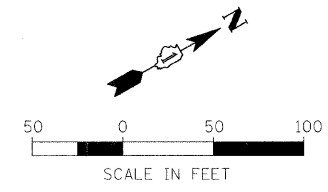

FILE NAME = #FILE#	USER NAME = #USER#	DESIGNED -	REVISED -	STATE OF ILLINOIS DEPARTMENT OF TRANSPORTATION	I-57 PROPOSED LIGHTING PLAN, STA. 1250+00 TO 1280+00			F.A.I. RTE. 157	SECTION 2008-082L	COUNTY COOK/WILL	TOTAL SHEETS 49	SHEET NO. 16
	PLOT SCALE = #SCALE#	DRAWN -	REVISED -		SCALE: 1"=50'-0"	SHEET NO.	OF	SHEETS	STA. 1250+00	TO STA. 1280+00	CONTRACT NO. 60F84	
	PLOT DATE = #DATE#	CHECKED -	REVISED -								ILLINOIS FED. AID PROJECT	
		DATE -	REVISED -									

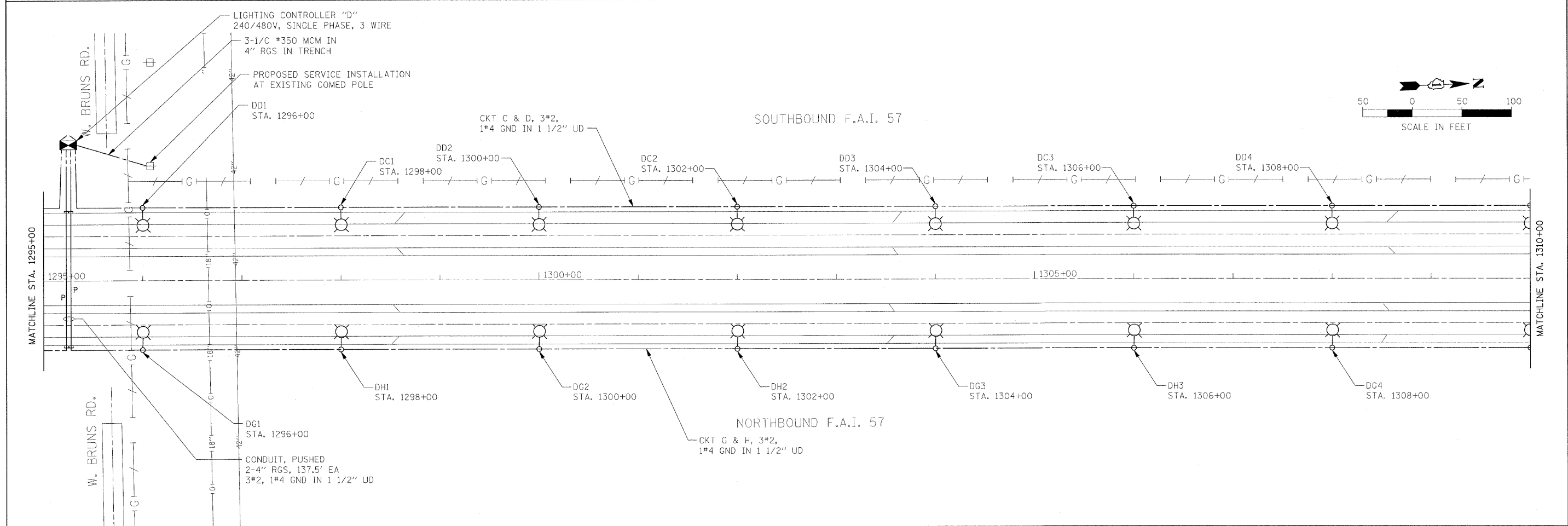
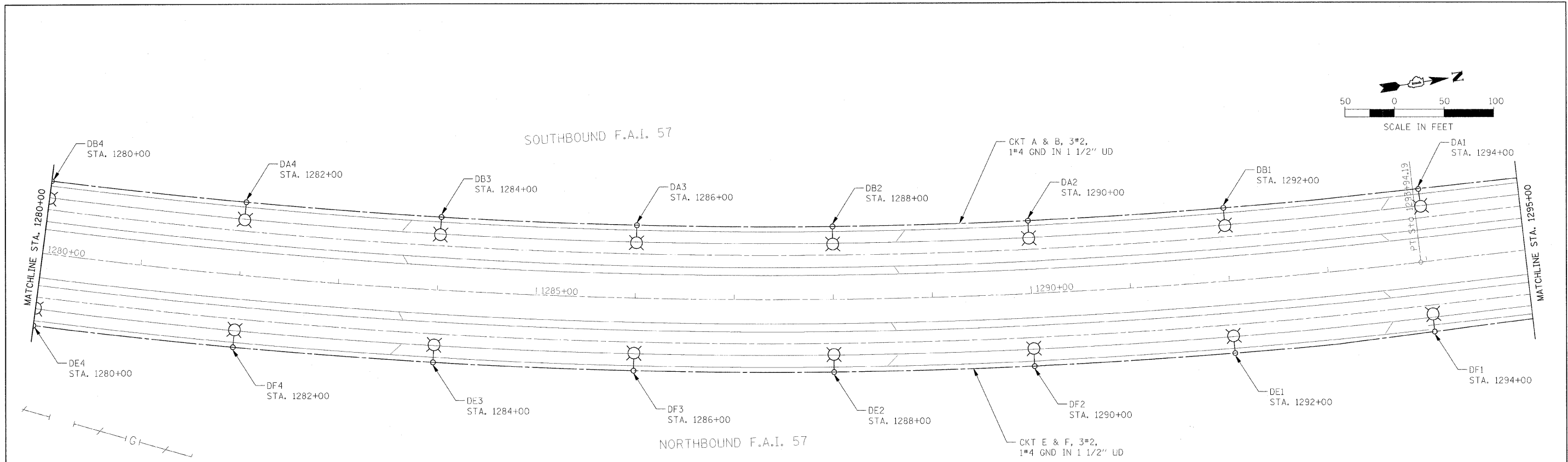

FILE NAME = #FILE#	USER NAME = #USER#	DESIGNED -	REVISD -	STATE OF ILLINOIS DEPARTMENT OF TRANSPORTATION	I-57 PROPOSED LIGHTING PLAN, STA. 1280+00 TO 1310+00			F.A.I. RTE. 157	SECTION 2008-082L	COUNTY COOK/WILL	TOTAL SHEETS 49	SHEET NO. 17
	PLOT SCALE = #SCALE#	DRAWN -	REVISD -		SCALE: 1"=50'-0"	SHEET NO.	OF	SHEETS	STA. 1280+00	TO STA. 1310+00	CONTRACT NO. 60F84	
	PLOT DATE = #DATE#	CHECKED -	REVISD -		ILLINOIS FED. AID PROJECT							
		DATE -	REVISD -									

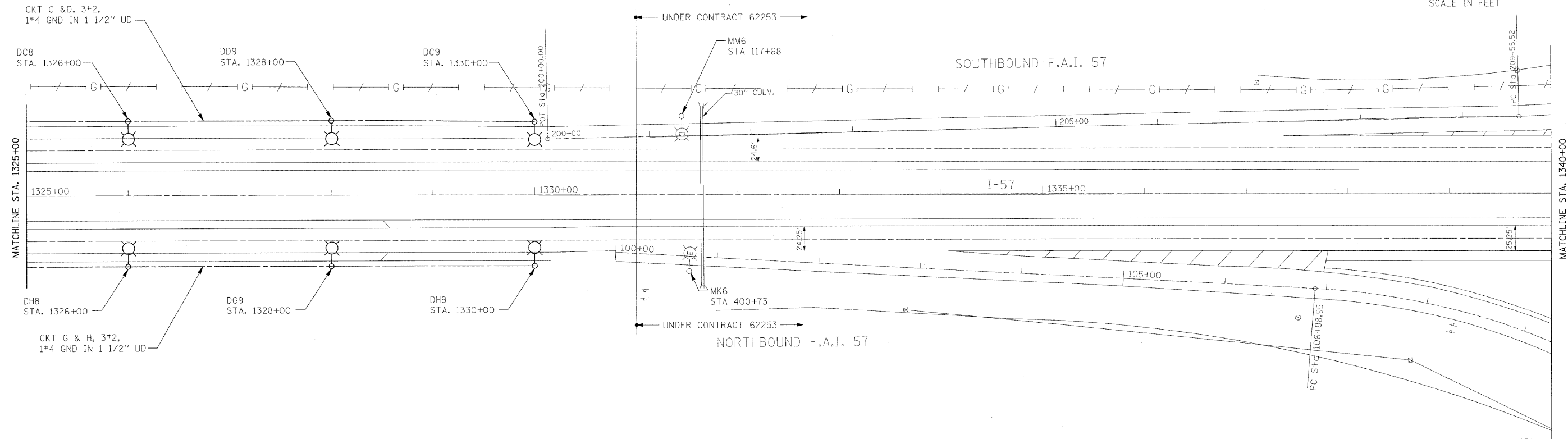
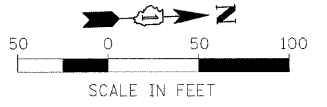
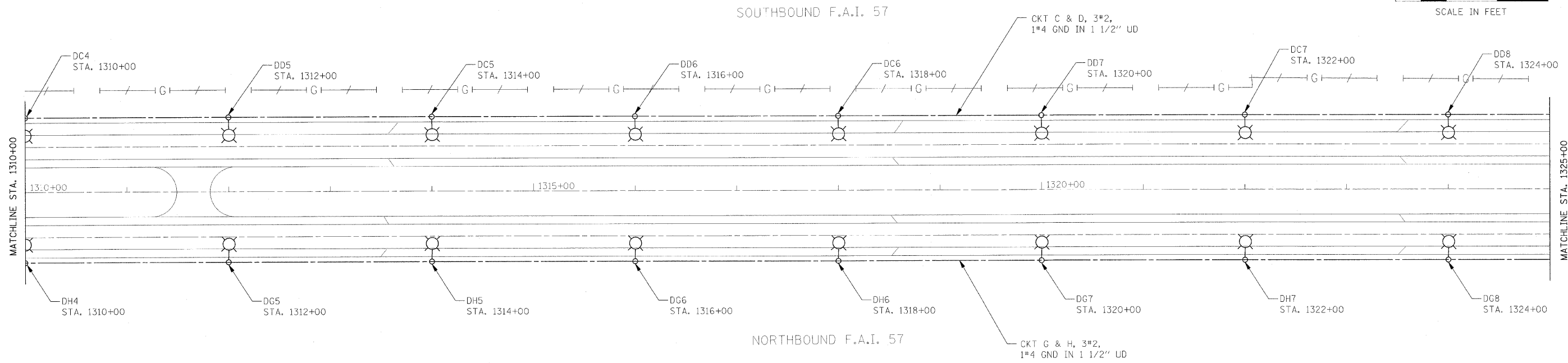
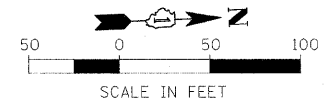

FILE NAME = #FILE#	USER NAME = #USER#	DESIGNED -	REVISED -	STATE OF ILLINOIS DEPARTMENT OF TRANSPORTATION	I-57 PROPOSED LIGHTING PLAN, STA. 1310+00 TO 1340+00			F.A.I. RTE.	SECTION	COUNTY	TOTAL SHEETS	SHEET NO.
	PLOT SCALE = #SCALE#	DRAWN -	REVISED -					157	2008-082L	COOK/WILL	49	18
	PLOT DATE = #DATE#	CHECKED -	REVISED -		SCALE: 1"=50'-0" SHEET NO. OF SHEETS STA. 1310+00 TO STA. 1340+00			CONTRACT NO. 60F84				
		DATE -	REVISED -					ILLINOIS FED. AID PROJECT				

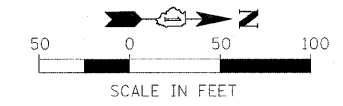

EXIST. CURVE CURAB1
 PI STA. = 211+51.53
 $\Delta = 31^\circ 56' 42''$ (LT)
 $D = 8^\circ 22' 00''$
 $R = 684.81'$
 $T = 196.01'$
 $L = 381.81'$
 $E = 27.50'$
 $e = \text{-----}$
 $T.R. = \text{-----}$
 $S.E. \text{ RUN} = \text{-----}$
 $P.C. \text{ STA.} = 209+55.52$
 $P.T. \text{ STA.} = 213+37.33$

EXIST. CURVE CURAB2
 PI STA. = 223+44.13
 $\Delta = 43^\circ 46' 58''$ (RT)
 $D = 12^\circ 36' 47''$
 $R = 454.26'$
 $T = 182.53'$
 $L = 347.12'$
 $E = 35.30'$
 $e = \text{-----}$
 $T.R. = \text{-----}$
 $S.E. \text{ RUN} = \text{-----}$
 $P.C. \text{ STA.} = 221+61.60$
 $P.T. \text{ STA.} = 225+08.72$

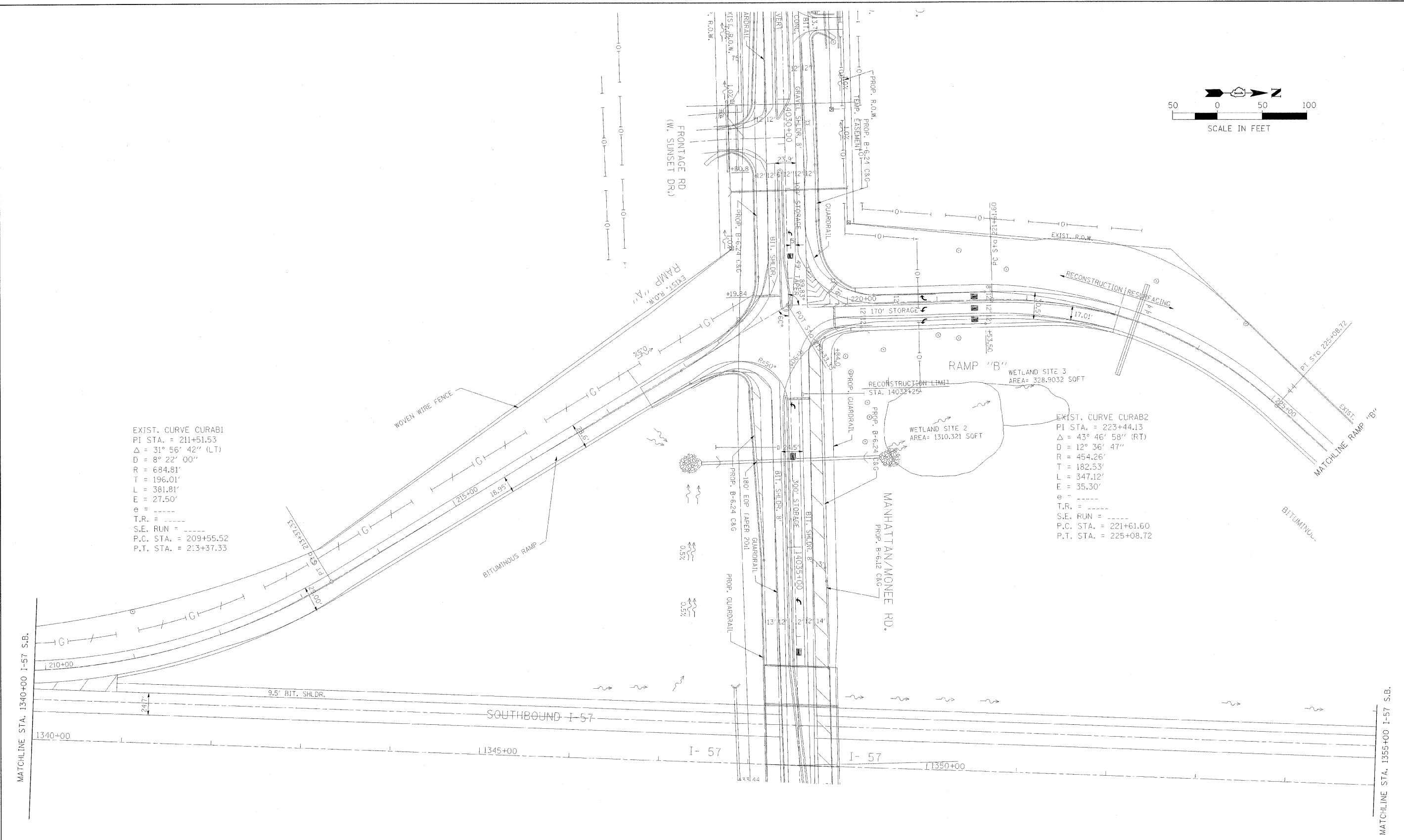

FOR REFERENCE ONLY
 CONSTRUCTED
 UNDER CONTRACT 62253

FILE NAME =	USER NAME = #USER#	DESIGNED -	REVISED -	STATE OF ILLINOIS DEPARTMENT OF TRANSPORTATION	I-57 PROPOSED LIGHTING PLAN, STA. 1340+00 TO 1355+00 (SB)	F.A.I. RTE.	SECTION	COUNTY	TOTAL SHEETS	SHEET NO.	
#FILEL#		DRAWN -	REVISED -			157	2008-082L	COOK/WILL	49	19	
	PLOT SCALE = #SCALE#	CHECKED -	REVISED -			CONTRACT NO. 60F84					
	PLOT DATE = #DATE#	DATE -	REVISED -			[ILLINOIS] FED. AID PROJECT					
					SCALE: 1"=50'-0"	SHEET NO. OF SHEETS	STA. 1340+00 TO STA. 1355+00				

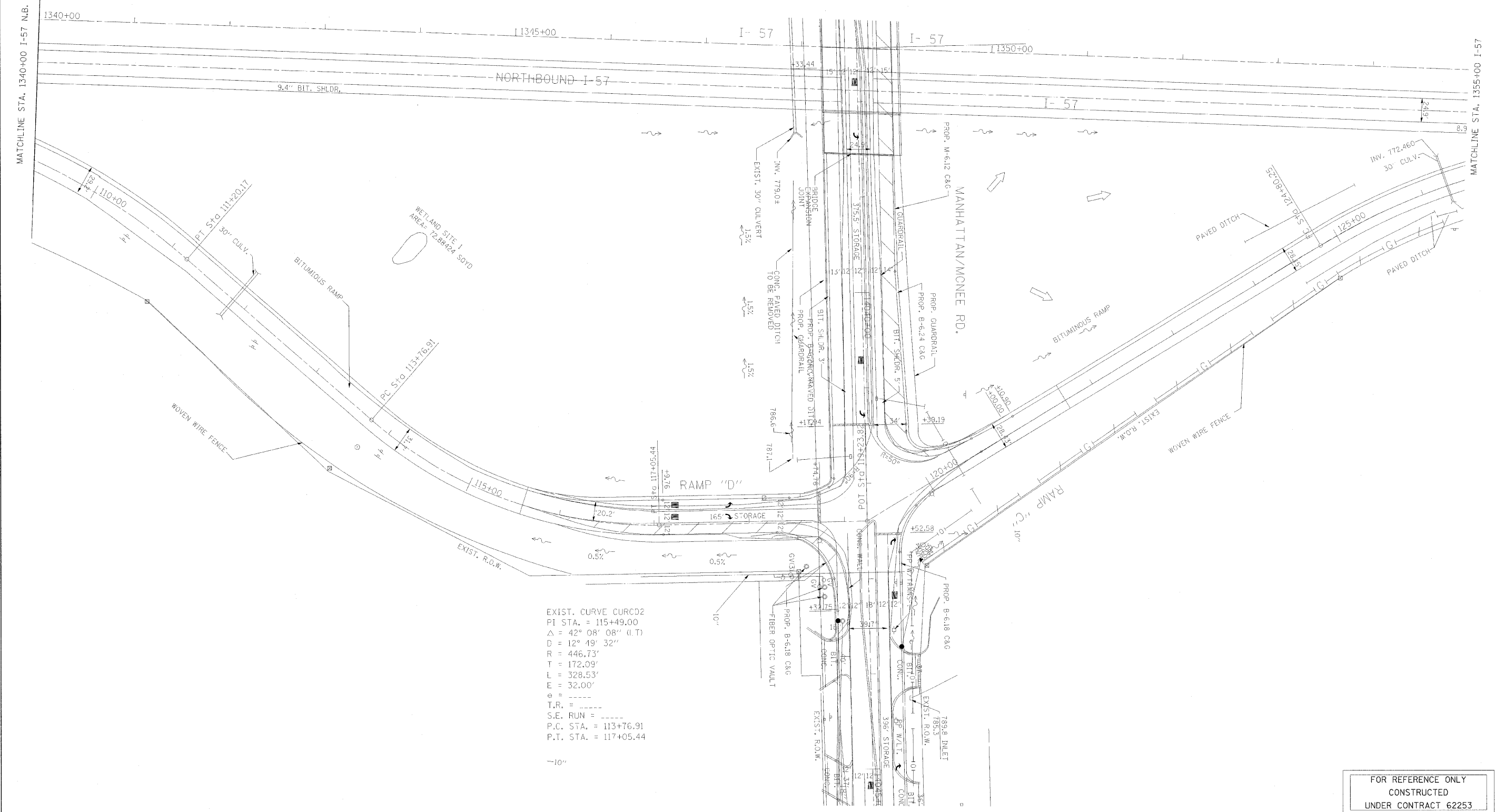
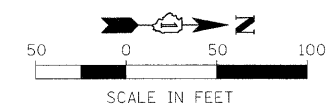

EXIST. CURVE CURCD2
 PI STA. = 115+49.00
 $\Delta = 42^\circ 08' 08''$ (I.T)
 $D = 12^\circ 49' 32''$
 $R = 446.73'$
 $T = 172.09'$
 $L = 328.53'$
 $E = 32.00'$
 $e = \text{---}$
 $T.R. = \text{---}$
 $S.E. \text{ RUN} = \text{---}$
 $P.C. \text{ STA.} = 113+76.91$
 $P.T. \text{ STA.} = 117+05.44$

FOR REFERENCE ONLY
 CONSTRUCTED
 UNDER CONTRACT 62253

FILE NAME =	USER NAME = #USER#	DESIGNED -	REVISED -
#FILE#		DRAWN -	REVISED -
	PLOT SCALE = #SCALE#	CHECKED -	REVISED -
	PLOT DATE = #DATE#	DATE -	REVISED -

STATE OF ILLINOIS
DEPARTMENT OF TRANSPORTATION

I-57 PROPOSED LIGHTING PLAN,
STA. 1340+00 TO 1355+00 (NB)

SCALE: 1"=50'-0" SHEET NO. OF SHEETS STA. 1340+00 TO STA. 1355+00

F.A.I. RTE.	SECTION	COUNTY	TOTAL SHEETS	SHEET NO.
157	2008-082L	COOK/WILL	49	20
CONTRACT NO. 60F84				
ILLINOIS FED. AID PROJECT				

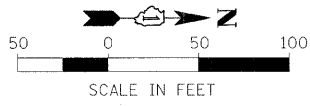

EXIST. CURVE CURA33
 PI STA. = 229+95.60
 $\Delta = 37^\circ 17' 22''$ (LT)
 $D = 8^\circ 12' 02''$
 $R = 698.68'$
 $T = 235.74'$
 $L = 454.72'$
 $E = 38.70'$
 $e = \text{-----}$
 T.R. = -----
 S.E. RUN = -----
 P.C. STA. = 227+59.86
 P.T. STA. = 232+14.58

RAMP "B" (TO MANHATTAN-MONEE ROAD)
 MATCHLINE RAMP "B"
 BITUMINOUS RAMP

WETLAND SITE 4
 TOTAL AREA = 555.9811 SOYD
 AREA IN R.O.W. = 277.6714 SOYD

MATCHLINE STA. 1355+00

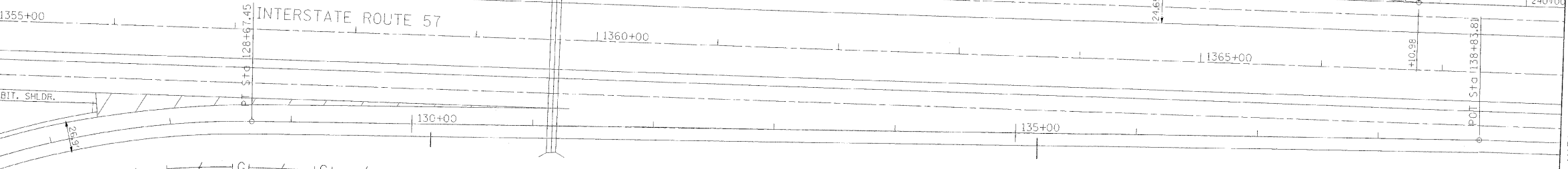

RAMP "C" FROM
 MANHATTAN-MONEE ROAD

EXIST. CURVE CURC03
 PI STA. = 126+79.10
 $\Delta = 32^\circ 10' 22''$ (RT)
 $D = 8^\circ 18' 33''$
 $R = 689.55'$
 $T = 198.85'$
 $L = 387.19'$
 $E = 28.10'$
 $e = \text{-----}$
 T.R. = -----
 S.E. RUN = -----
 P.C. STA. = 124+80.25
 P.T. STA. = 128+67.45

FOR REFERENCE ONLY
 CONSTRUCTED
 UNDER CONTRACT 62253

FILE NAME = #FILE#	USER NAME = #USER#	DESIGNED -	REVISED -	STATE OF ILLINOIS DEPARTMENT OF TRANSPORTATION	I-57 PROPOSED LIGHTING PROJECT STA. 1355+00 TO 1368+00			F.A.I. RTE.	SECTION	COUNTY	TOTAL SHEETS	SHEET NO.
	PLOT SCALE = #SCALE#	DRAWN -	REVISED -					157	2008-082L	COOK/WILL	49	21
PLOT DATE = #DATE#	CHECKED -	REVISED -	SCALE: 1"=50'-0" SHEET NO. OF SHEETS STA. 1355+00 TO STA. 1368+00			CONTRACT NO. 60F84						
	DATE -	REVISED -	ILLINOIS FED. AID PROJECT									

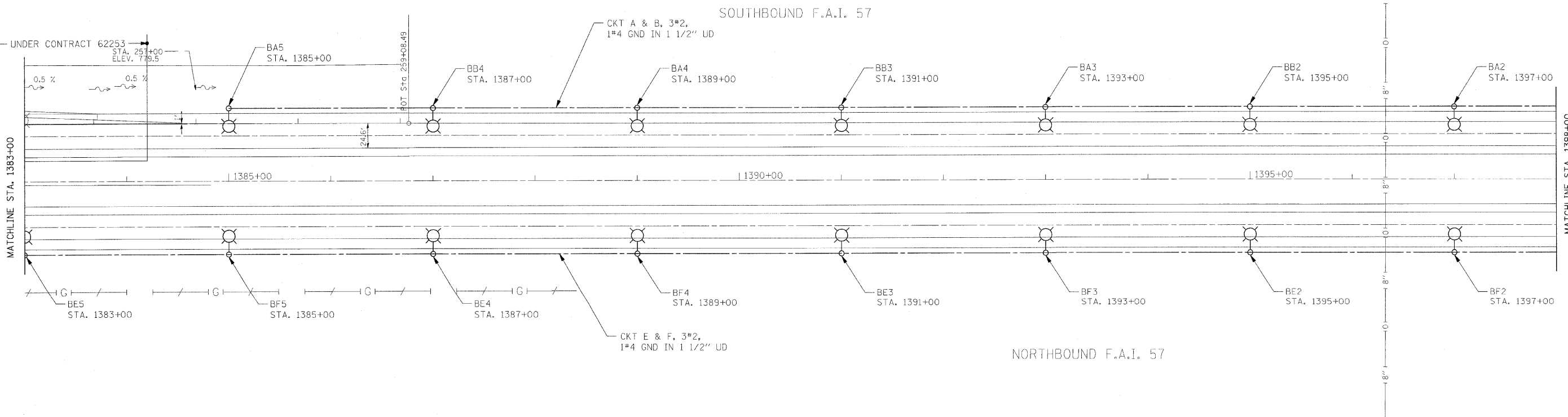
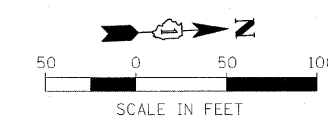
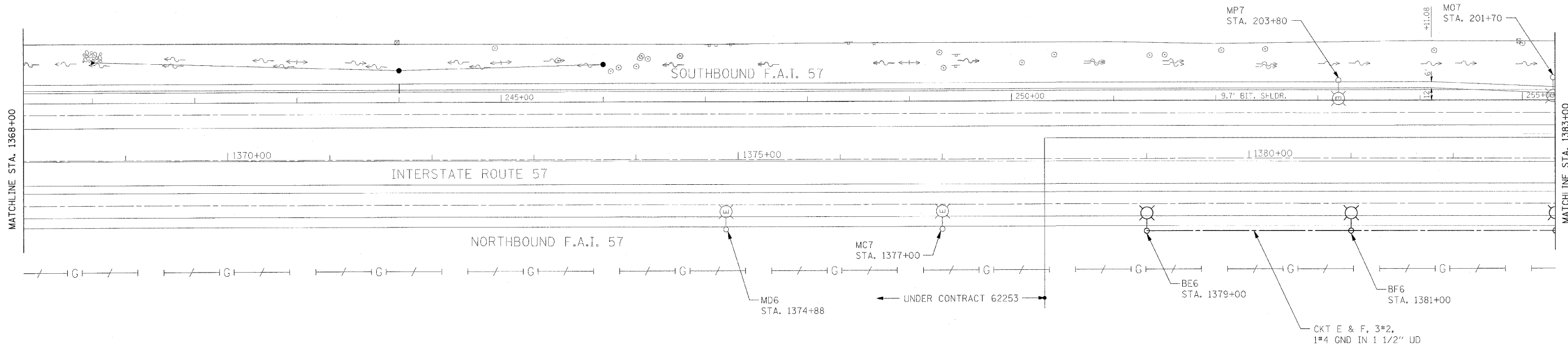
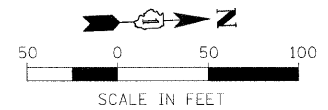

FILE NAME = #FILE#	USER NAME = #USER#	DESIGNED -	REVISED -	STATE OF ILLINOIS DEPARTMENT OF TRANSPORTATION	I-57 PROPOSED LIGHTING PLAN, STA. 1368+00 TO 1398+00			F.A.I. RTE.	SECTION	COUNTY	TOTAL SHEETS	SHEET NO.
	PLOT SCALE = #SCALE#	DRAWN -	REVISED -					157	2008-082L	COOK/WILL	49	22
	PLOT DATE = #DATE#	CHECKED -	REVISED -		SCALE: 1"=50'-0" SHEET NO. OF SHEETS STA. 1368+00 TO STA. 1398+00			CONTRACT NO. 60F84				
		DATE -	REVISED -		ILLINOIS FED. AID PROJECT							

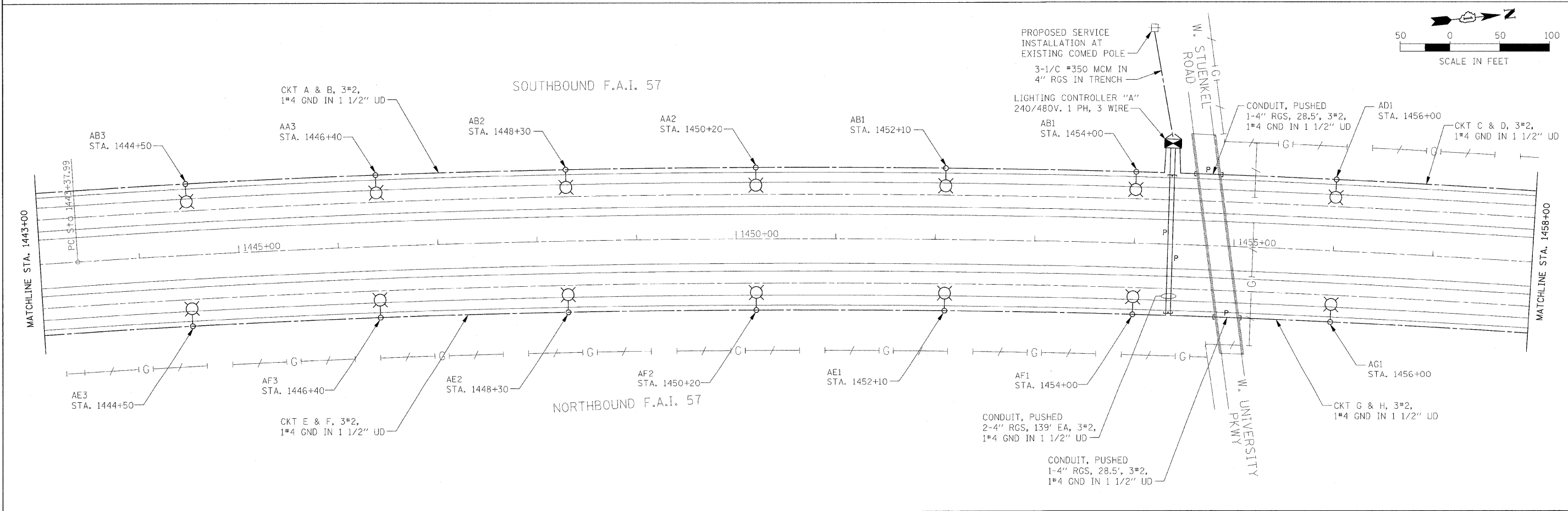
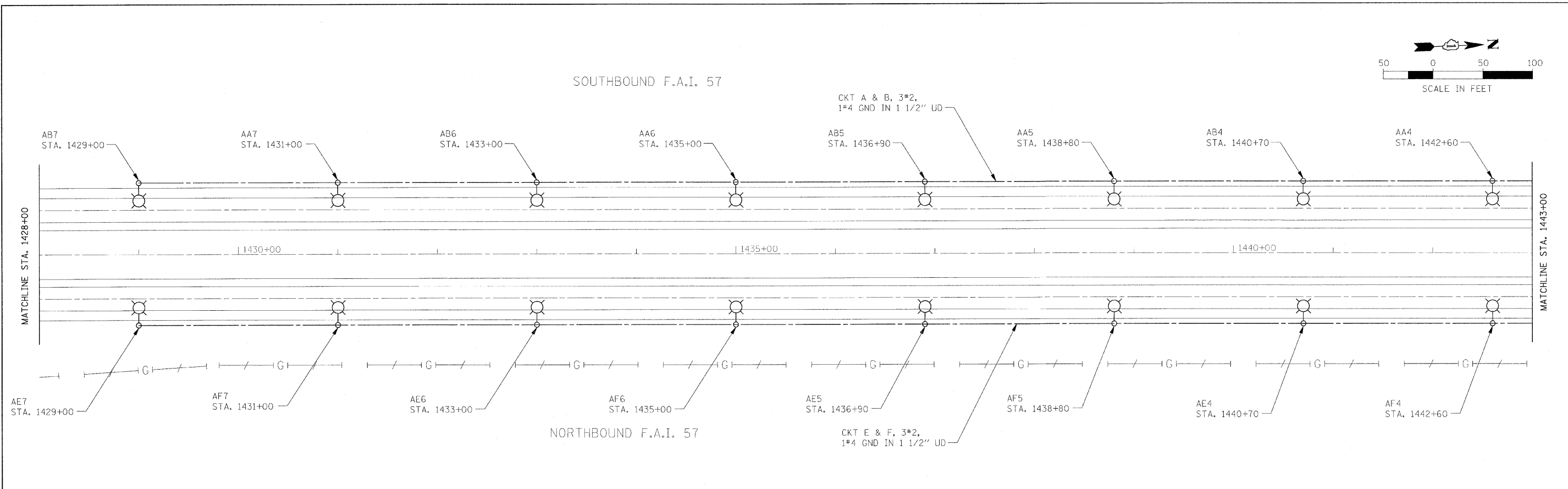

FILE NAME = \$FILEL\$	USER NAME = \$USER\$	DESIGNED -	REVISED -	STATE OF ILLINOIS DEPARTMENT OF TRANSPORTATION	I-57 PROPOSED LIGHTING PLAN STA. 1428+00 TO 1458+00		F.A.I. RTE. 157	SECTION 2008-082L	COUNTY COOK/WILL	TOTAL SHEETS 49	SHEET NO. 24	
	PLOT SCALE = \$SCALE\$	DRAWN -	REVISED -		SCALE: 1"=50'-0"	SHEET NO. OF SHEETS	STA. 1428+00 TO STA. 1458+00	CONTRACT NO. 60F84				
	PLOT DATE = \$DATE\$	CHECKED -	REVISED -		ILLINOIS FED. AID PROJECT							
		DATE -	REVISED -									

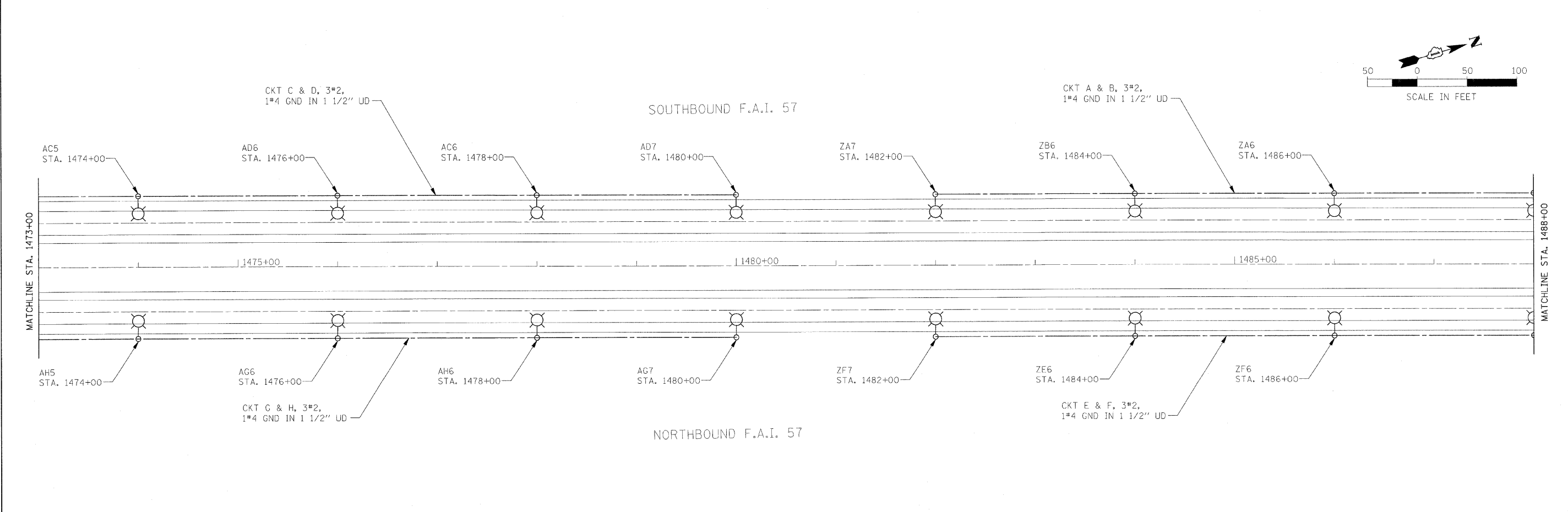
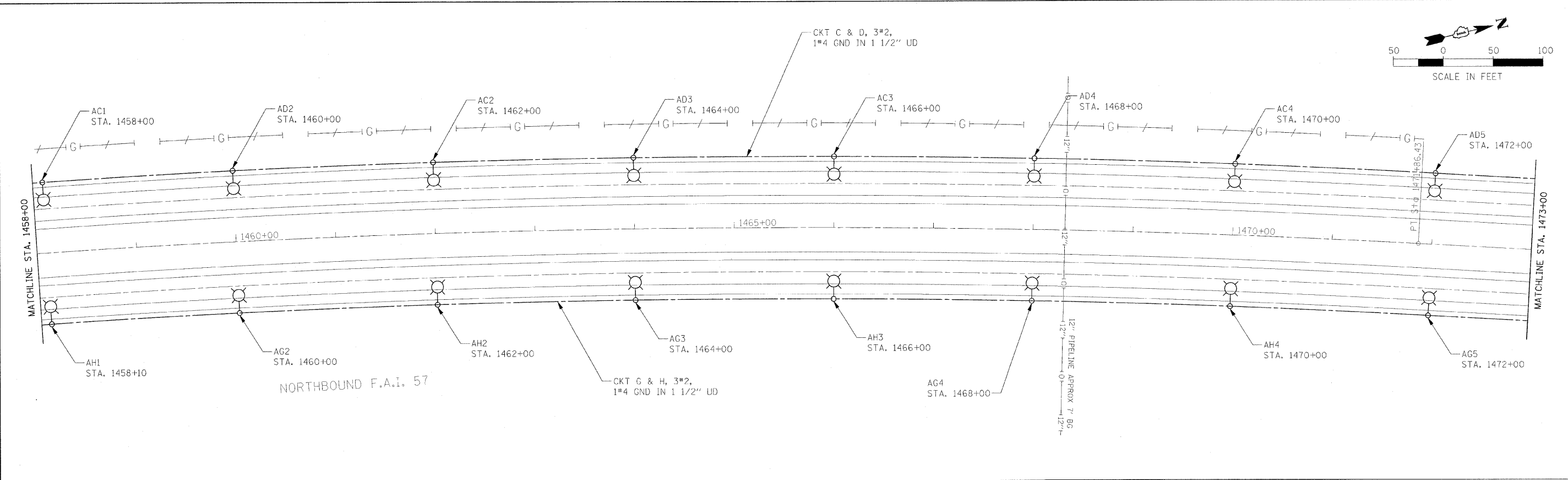

FILE NAME = #FILEL#	USER NAME = #USER#	DESIGNED -	REVISED -	STATE OF ILLINOIS DEPARTMENT OF TRANSPORTATION	I-57 PROPOSED LIGHTING PLAN STA. 1458+00 TO 1488+00			F.A.I. RTE.	SECTION	COUNTY	TOTAL SHEETS	SHEET NO.
	PLOT SCALE = #SCALE#	DRAWN -	REVISED -		157	2008-082L	COOK/WILL	49	25			
	PLOT DATE = #DATE#	CHECKED -	REVISED -		SCALE: 1"=50'-0" SHEET NO. OF SHEETS STA. 1458+00 TO STA. 1488+00			CONTRACT NO. 60F84				
		DATE -	REVISED -		ILLINOIS FED. AID PROJECT							

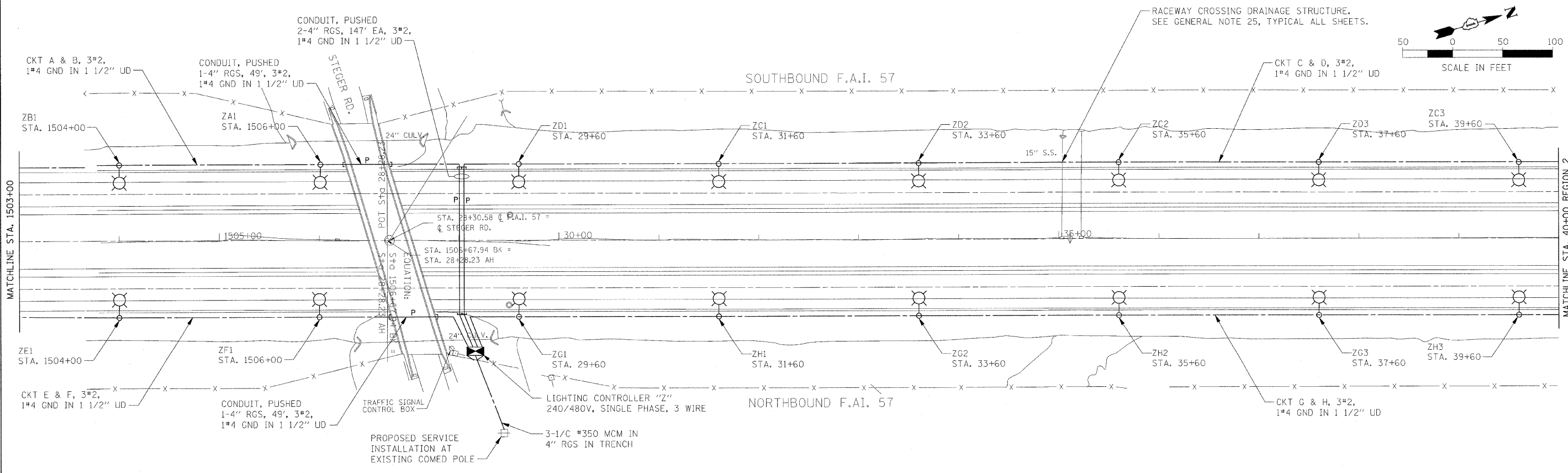
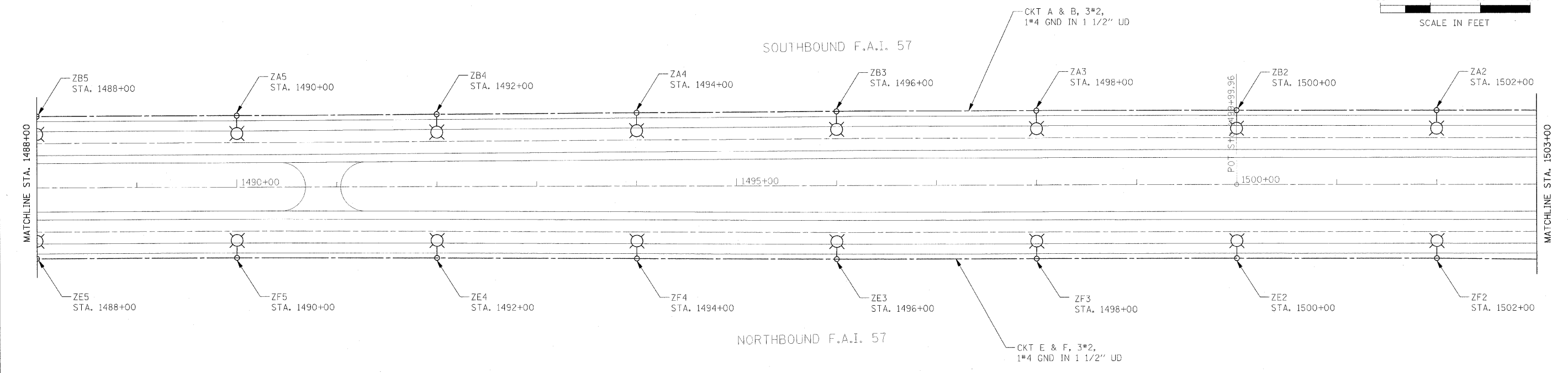
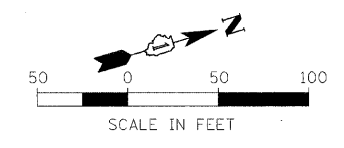

FILE NAME =	USER NAME = #USER#	DESIGNED -	REVISED -	STATE OF ILLINOIS DEPARTMENT OF TRANSPORTATION	I-57 PROPOSED LIGHTING PLAN STA. 1488+00 TO 40+00 REGION 2		F.A.I. RTE.	SECTION	COUNTY	TOTAL SHEETS	SHEET NO.
#FILE#		DRAWN -	REVISED -		SCALE: 1"=50'-0"	SHEET NO. OF SHEETS	157	2008-082L	COOK/WILL	49	26
	PLOT SCALE = #SCALE#	CHECKED -	REVISED -		STA. 1488+00 TO STA. 40+00 (2)						
	PLOT DATE = #DATE#	DATE -	REVISED -								
							CONTRACT NO. 60F84		ILLINOIS FED. AID PROJECT		

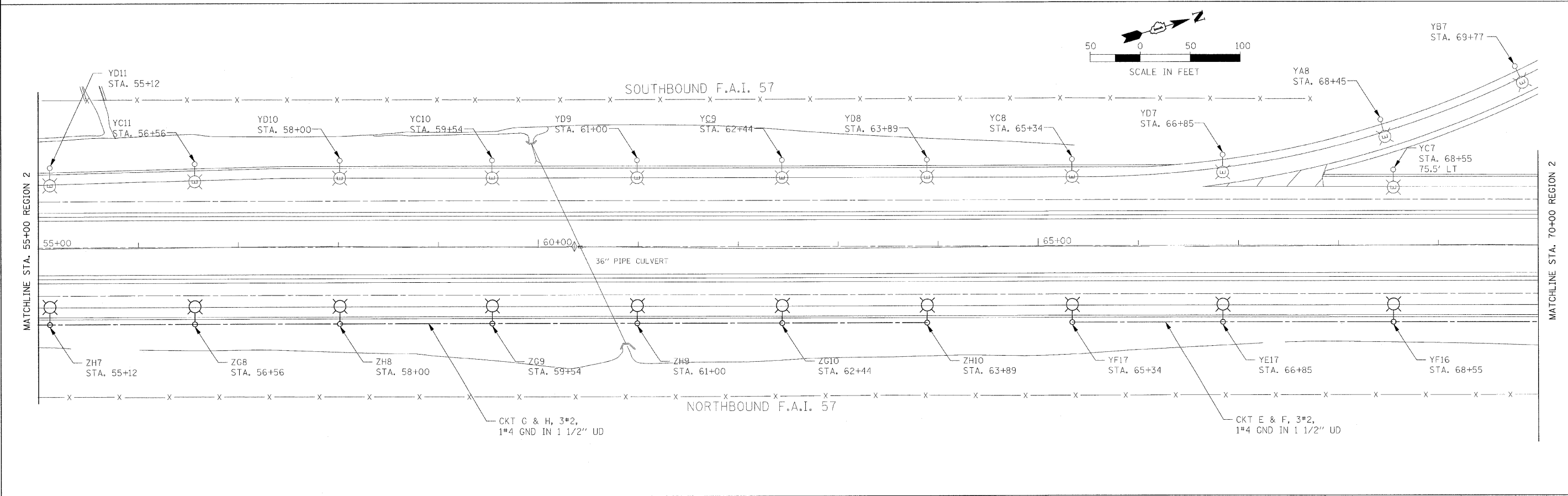
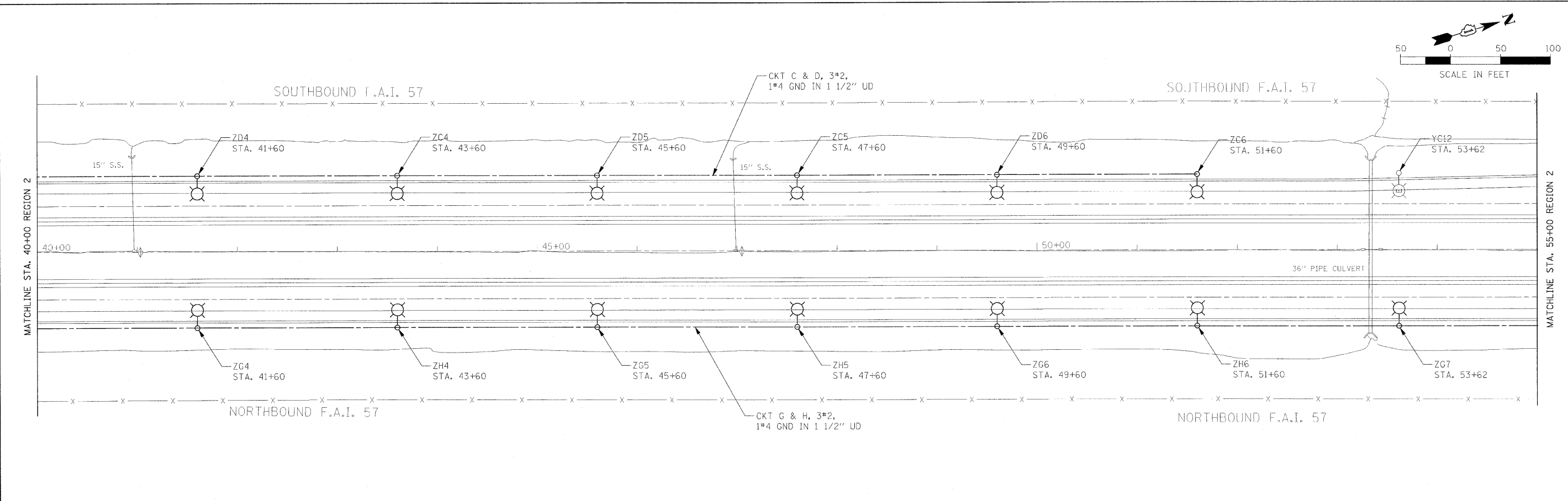

FILE NAME = #FILEL#	USER NAME = #USER#	DESIGNED -	REVISED -	STATE OF ILLINOIS DEPARTMENT OF TRANSPORTATION	I-57 PROPOSED LIGHTING PLAN STA. 40+00 TO 70+00 REGION 2		F.A.I. RTE.	SECTION	COUNTY	TOTAL SHEETS	SHEET NO.
	PLOT SCALE = #SCALE#	DRAWN -	REVISED -				157	2008-082L	COOK/WILL	49	27
	PLOT DATE = #DATE#	CHECKED -	REVISED -				CONTRACT NO. 60F84				
		DATE -	REVISED -				ILLINOIS FED. AID PROJECT				
					SCALE: 1"=50'-0"	SHEET NO. OF SHEETS	STA. 40+00 (2) TO STA. 70+00 (2)				

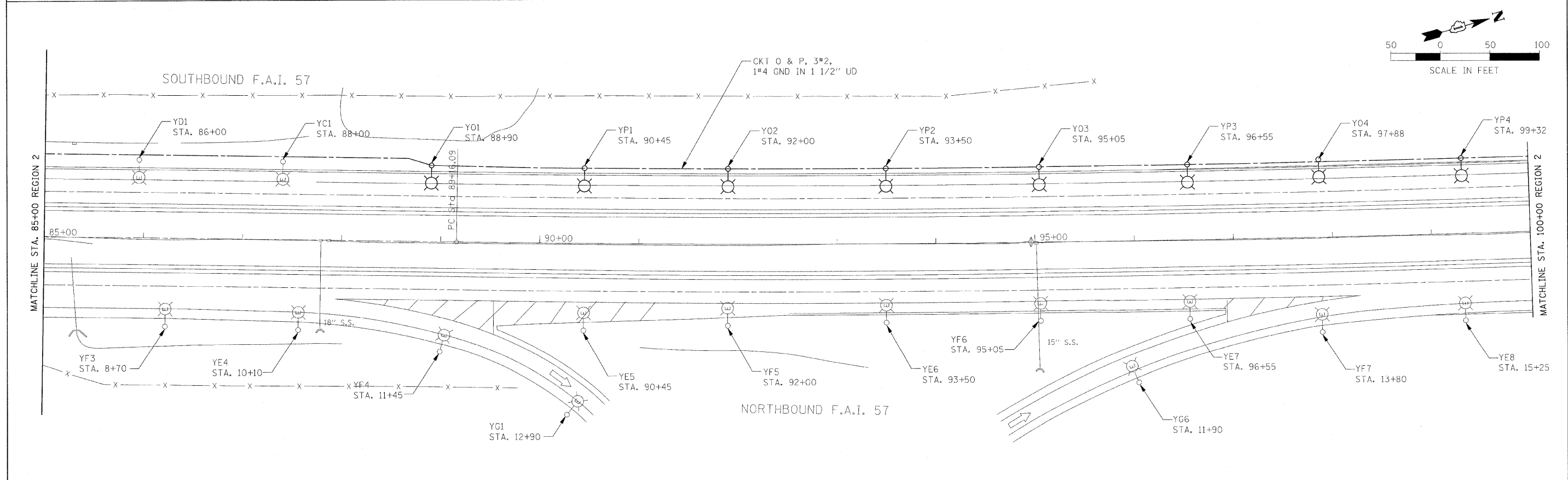
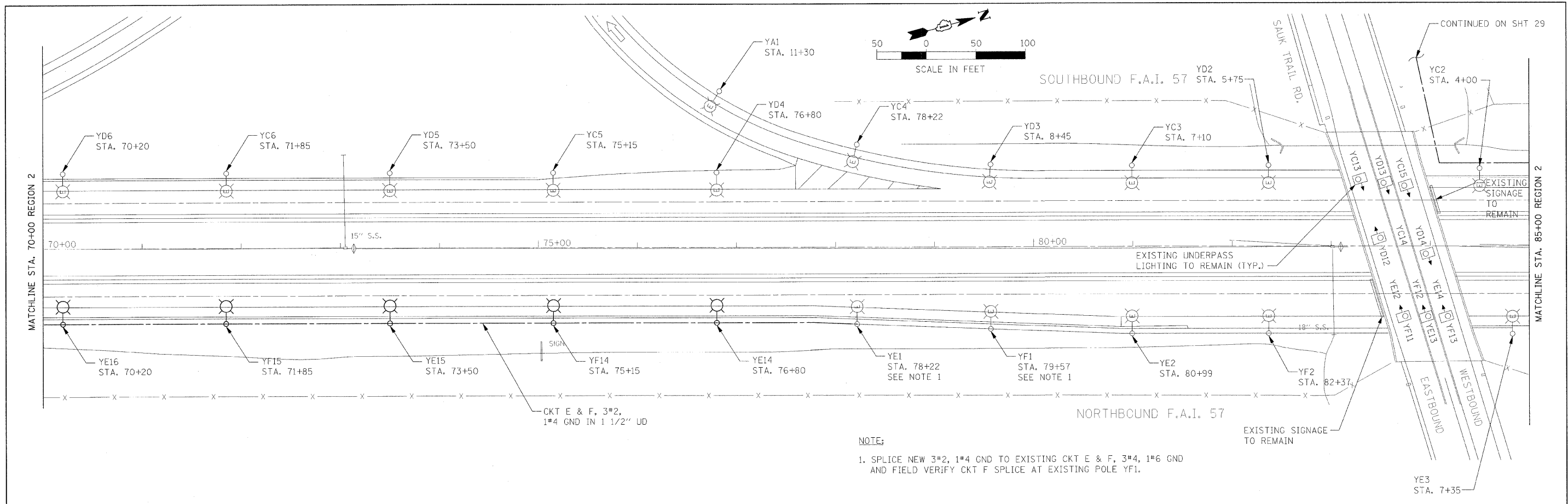

FILE NAME = #FILE#	USER NAME = #USER#	DESIGNED -	REVISD -	STATE OF ILLINOIS DEPARTMENT OF TRANSPORTATION	I-57 PROPOSED LIGHTING PLAN STA. 70+00 TO 100+00		F.A.I. RTE. 157	SECTION 2008-082L	COUNTY COOK/WILL	TOTAL SHEETS 49	SHEET NO. 28	
	PLOT SCALE = #SCALE#	DRAWN -	REVISD -		SCALE: 1"=50'-0"	SHEET NO. OF SHEETS	STA. 70+00 (2) TO STA. 100+00 (2)	CONTRACT NO. 60F84				
	PLOT DATE = #DATE#	CHECKED -	REVISD -		ILLINOIS FED. AID PROJECT							
		DATE -	REVISD -									

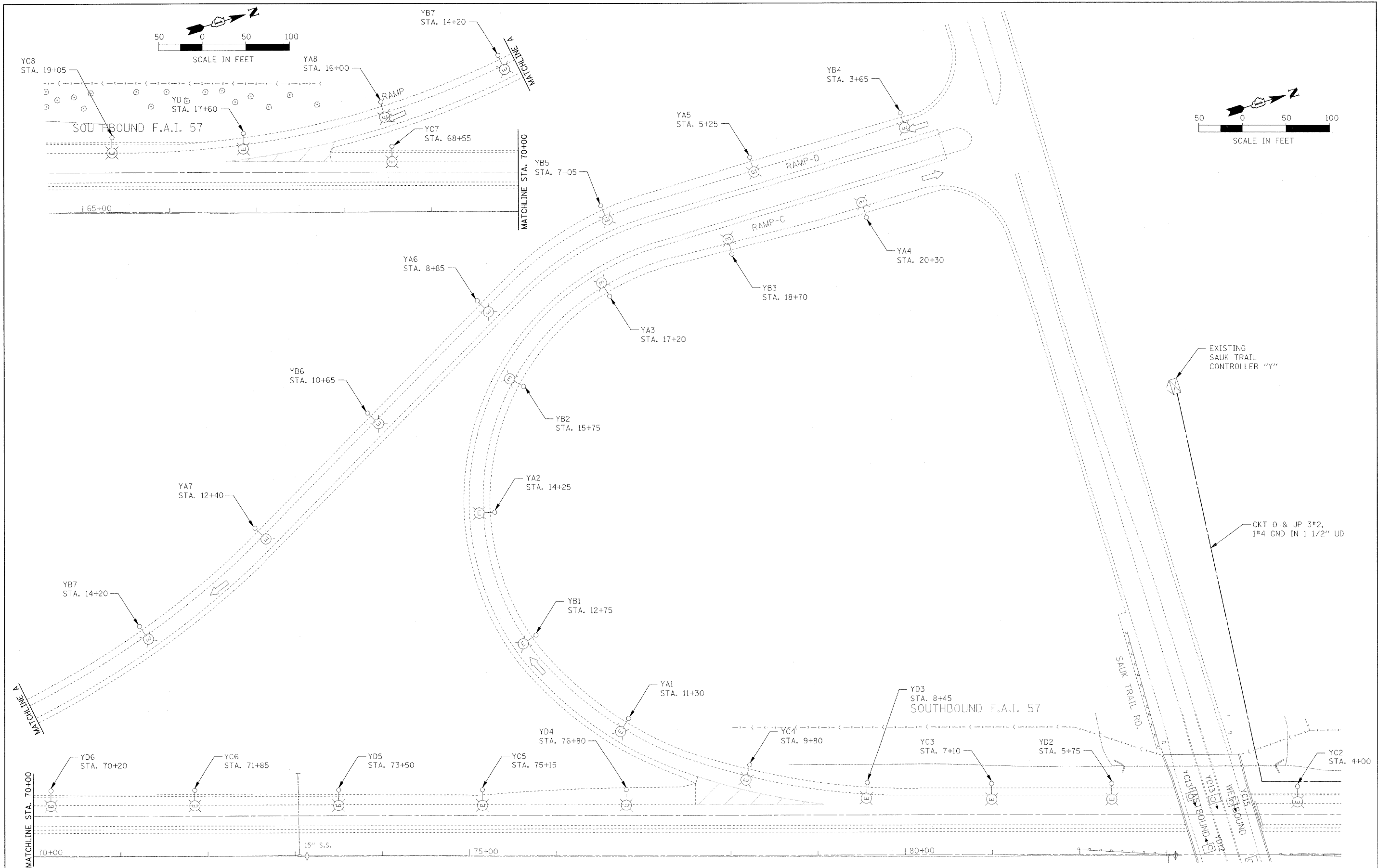

FILE NAME =
#FILE#

USER NAME = #USER#
PLOT SCALE = #SCALE#
PLOT DATE = #DATE#

DESIGNED -
DRAWN -
CHECKED -
DATE -

REVISED -
REVISED -
REVISED -
REVISED -

**STATE OF ILLINOIS
DEPARTMENT OF TRANSPORTATION**

**I-57 PROPOSED LIGHTING PLAN
SAUK TRAIL SB RAMP**

SCALE: 1"=50'-0" SHEET NO. OF SHEETS STA. 65+00 TO STA. 85+00

F.A.I. RTE.	SECTION	COUNTY	TOTAL SHEETS	SHEET NO.
157	2008-082L	COOK/WILL	49	29
			CONTRACT NO. 60F84	
ILLINOIS FED. AID PROJECT				

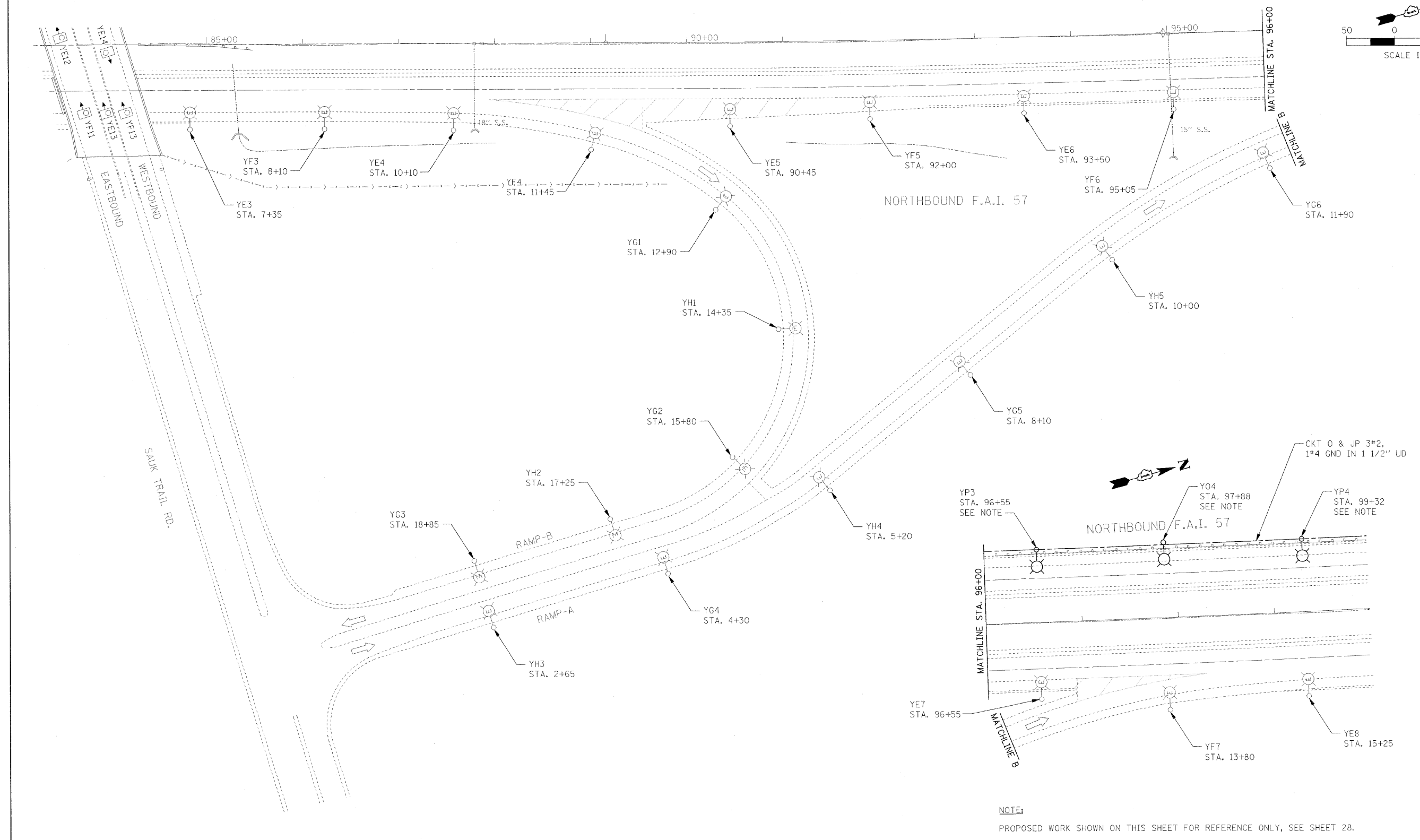
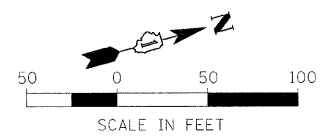

NOTE:
PROPOSED WORK SHOWN ON THIS SHEET FOR REFERENCE ONLY, SEE SHEET 28.

FILE NAME = #FILEL#	USER NAME = #USER#	DESIGNED -	REVISD -	STATE OF ILLINOIS DEPARTMENT OF TRANSPORTATION	I-57 PROPOSED LIGHTING PLAN SAULK TRAIL NB RAMPS			F.A.I. RTE.	SECTION	COUNTY	TOTAL SHEETS	SHEET NO.	
	PLOT SCALE = #SCALE#	DRAWN -	REVISD -		SCALE: 1"=50'-0"	SHEET NO.	OF	SHEETS	STA. 83+00	TO STA. 100+00	COOK/WILL	49	30
	PLOT DATE = #DATE#	CHECKED -	REVISD -								CONTRACT NO. 60F84		
		DATE -	REVISD -							ILLINOIS FED. AID PROJECT			

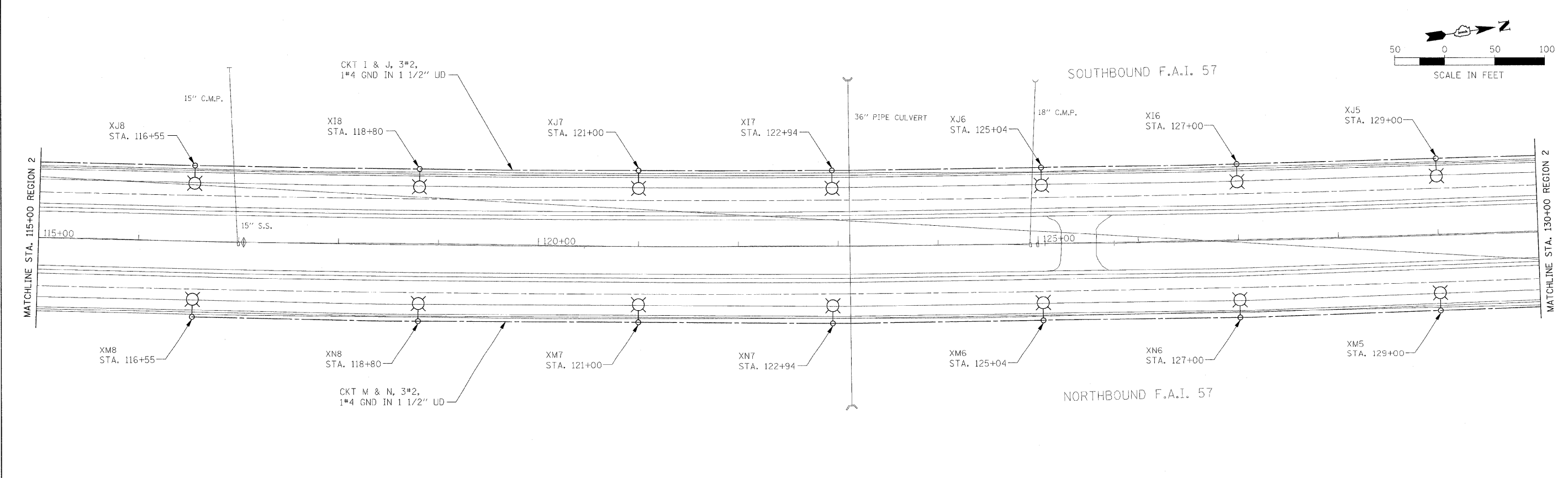
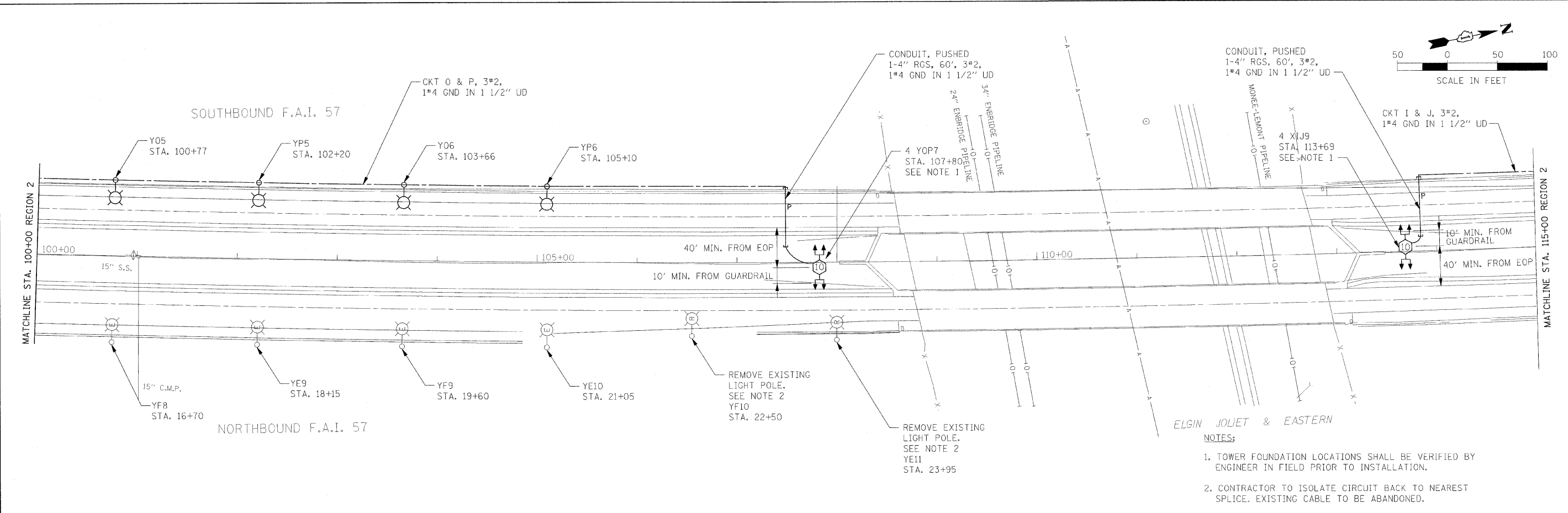

FILE NAME =	USER NAME = #USER#	DESIGNED -	REVISD -	STATE OF ILLINOIS DEPARTMENT OF TRANSPORTATION	I-57 PROPOSED LIGHTING PLAN STA. 100+00 TO 130+00 REGION 2		F.A.I. RTE.	SECTION	COUNTY	TOTAL SHEETS	SHEET NO.
#FILE#		DRAWN -	REVISD -		157	2008-082L	COOK/WILL	49	31		
	PLOT SCALE = #SCALE#	CHECKED -	REVISD -		SCALE: 1"=50'-0" SHEET NO. OF SHEETS STA. 100+00 (2) TO STA. 130+00 (2)		CONTRACT NO. 60F84				
	PLOT DATE = #DATE#	DATE -	REVISD -		ILLINOIS FED. AID PROJECT						

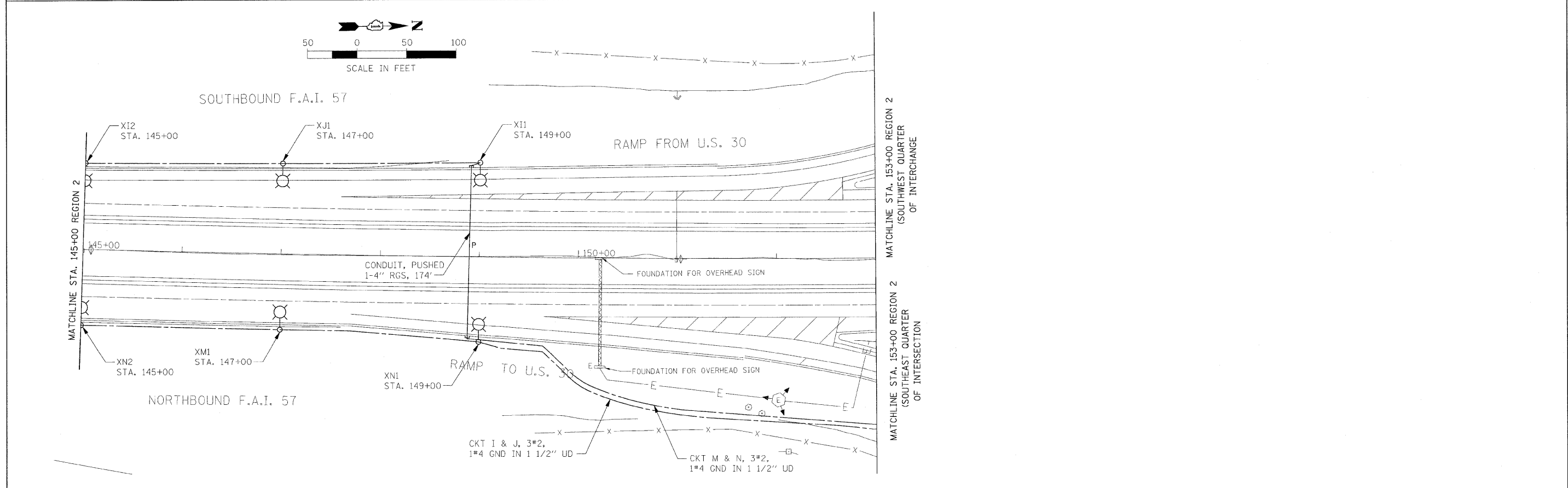
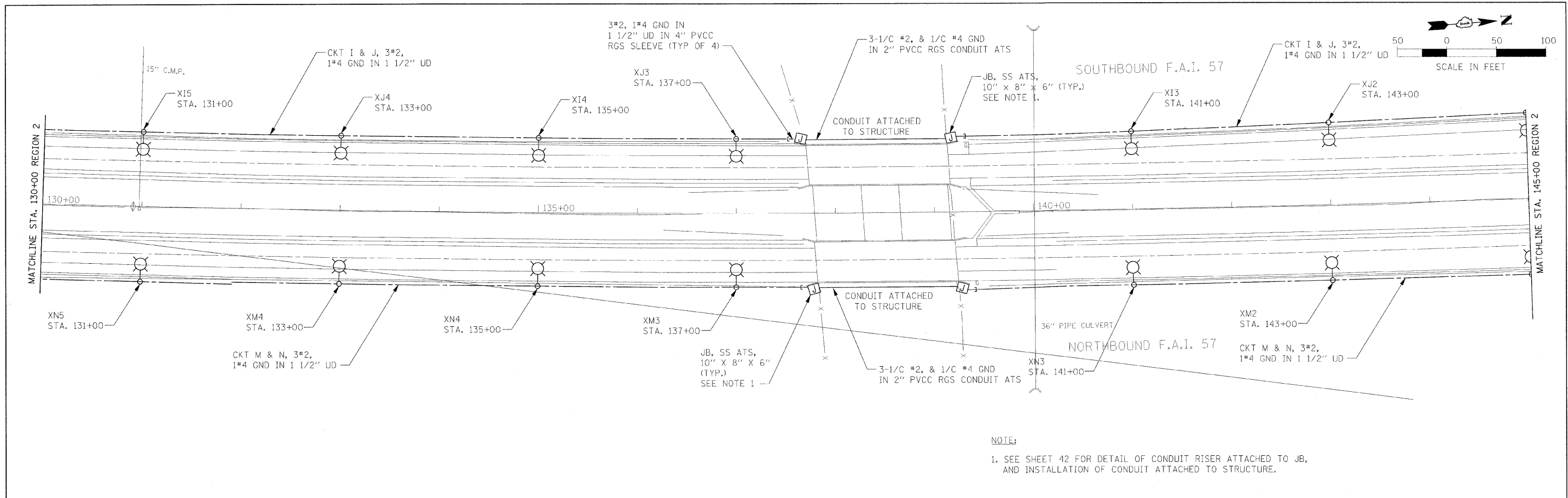

FILE NAME =	USER NAME = #USER#	DESIGNED -	REVISED -	STATE OF ILLINOIS DEPARTMENT OF TRANSPORTATION	I-57 PROPOSED LIGHTING PLAN STA. 130+00 TO 153+00 REGION 2			F.A.I. RTE.	SECTION	COUNTY	TOTAL SHEETS	SHEET NO.		
#FILEL#	PLOT SCALE = #SCALE#	DRAWN -	REVISED -		SCALE: 1"=50'-0"	SHEET NO.	OF	SHEETS	STA. 130+00 (2) TO STA. 153+00 (2)	157	2008-082L	COOK/WILL	49	32
	PLOT DATE = #DATE#	CHECKED -	REVISED -											
		DATE -	REVISED -											
										CONTRACT NO. 60F84			ILLINOIS FED. AID PROJECT	

MATCHLINE I-57 S.B. EXIT
TO U.S. 30 W.B.

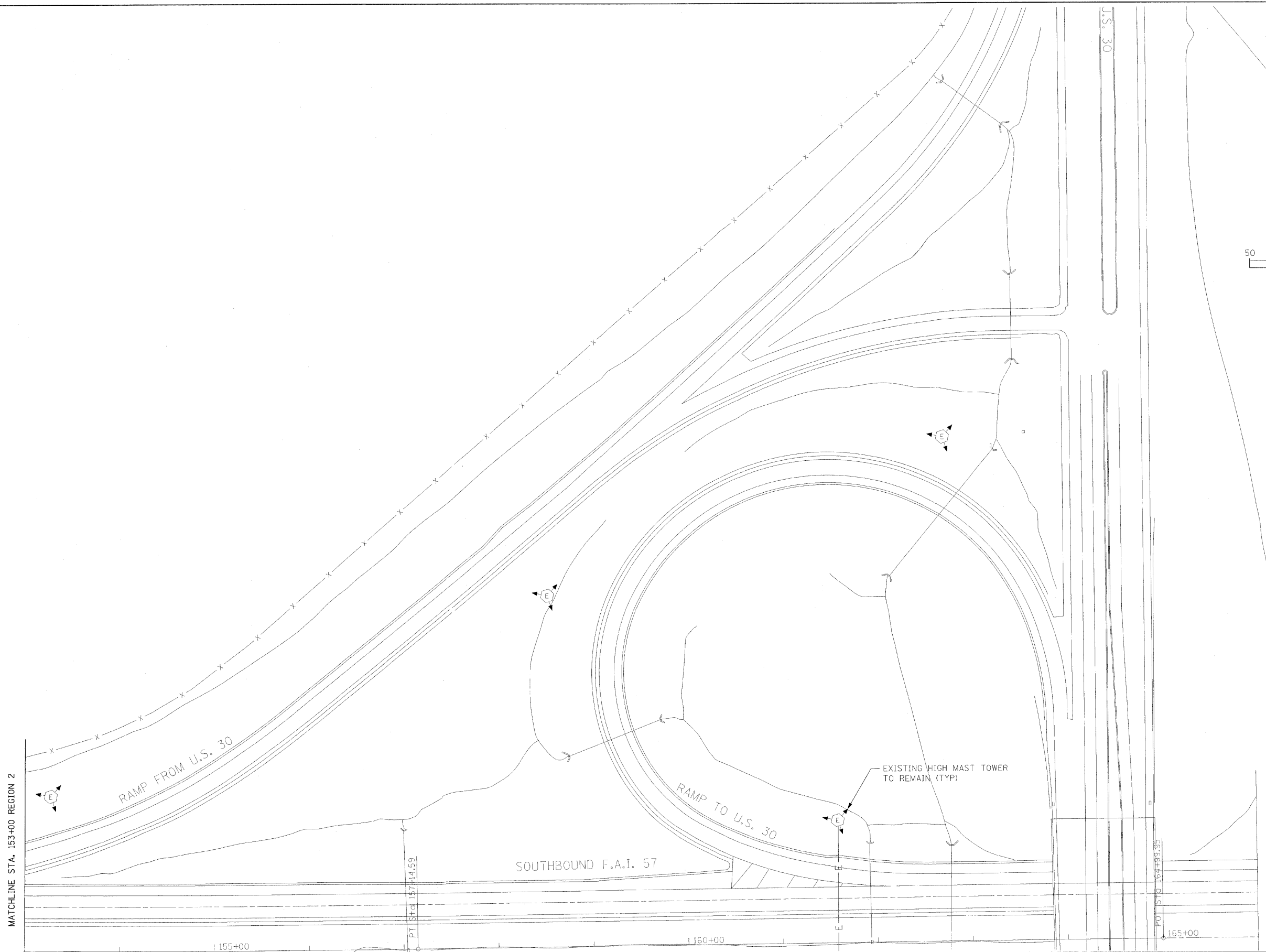
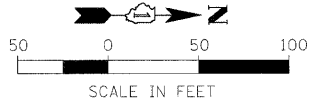

FOR REFERENCE ONLY
NO WORK SHOWN
ON THIS SHEET

FILE NAME =	USER NAME = #USER#	DESIGNED -	REVISED -	STATE OF ILLINOIS DEPARTMENT OF TRANSPORTATION	SOUTHBOUND SIDE OF I-57 AT U.S. 30 STA. 153+00 (2) TO 166+00 (2) (SOUTHWEST QUADRANT)			F.A.I. RTE.	SECTION	COUNTY	TOTAL SHEETS	SHEET NO.	
#FILEL#		DRAWN -	REVISED -		SCALE: 1"=50'-0"	SHEET NO.	OF	SHEETS	157	2008-082L	COOK/WILL	49	33
	PLOT SCALE = #SCALE#	CHECKED -	REVISED -		STA. 153+00 (2) TO STA. 166+00 (2)	CONTRACT NO. 60F84							
	PLOT DATE = #DATE#	DATE -	REVISED -		ILLINOIS FED. AID PROJECT								

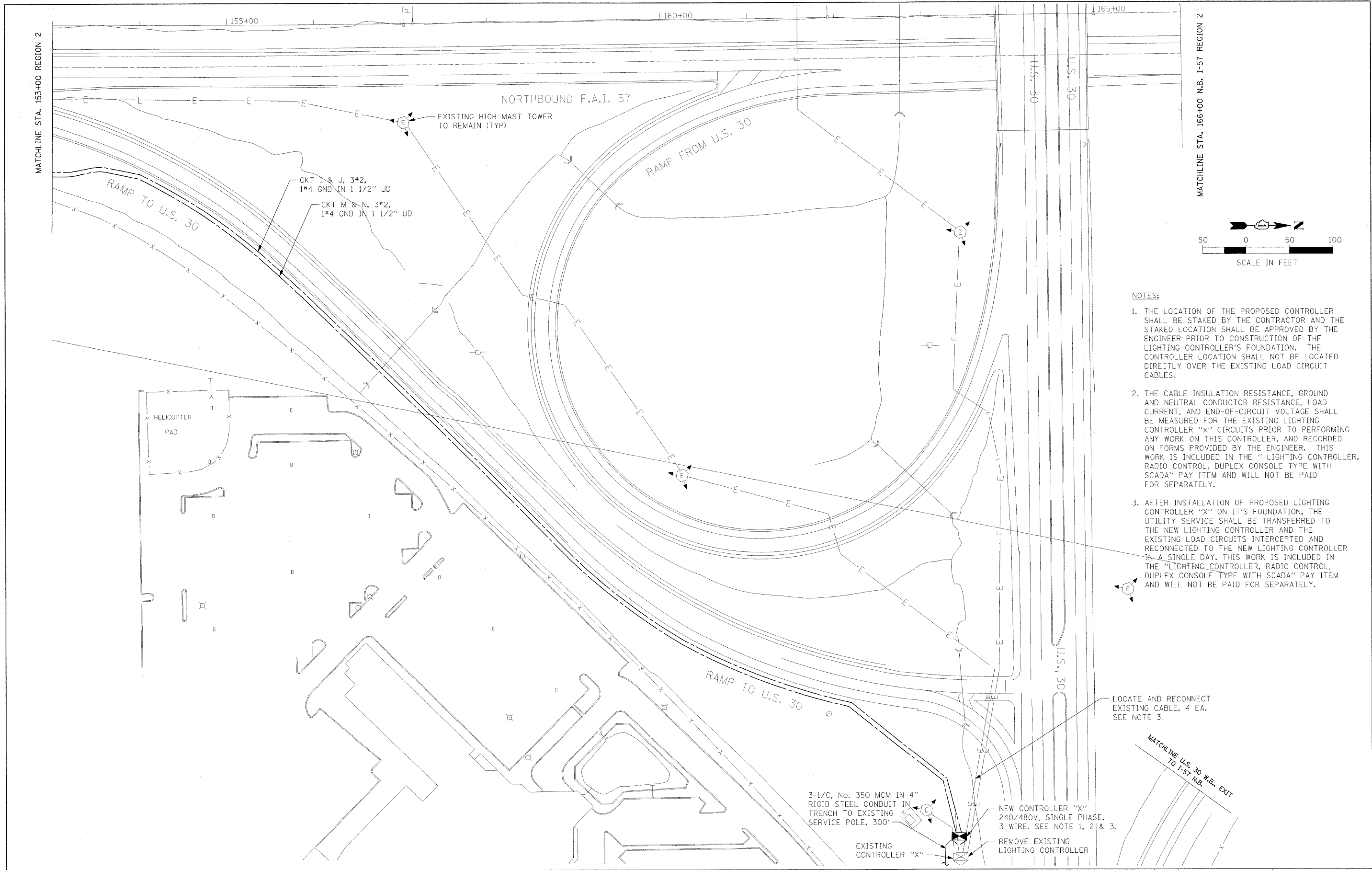

- NOTES:**
1. THE LOCATION OF THE PROPOSED CONTROLLER SHALL BE STAKED BY THE CONTRACTOR AND THE STAKED LOCATION SHALL BE APPROVED BY THE ENGINEER PRIOR TO CONSTRUCTION OF THE LIGHTING CONTROLLER'S FOUNDATION. THE CONTROLLER LOCATION SHALL NOT BE LOCATED DIRECTLY OVER THE EXISTING LOAD CIRCUIT CABLES.
 2. THE CABLE INSULATION RESISTANCE, GROUND AND NEUTRAL CONDUCTOR RESISTANCE, LOAD CURRENT, AND END-OF-CIRCUIT VOLTAGE SHALL BE MEASURED FOR THE EXISTING LIGHTING CONTROLLER "X" CIRCUITS PRIOR TO PERFORMING ANY WORK ON THIS CONTROLLER, AND RECORDED ON FORMS PROVIDED BY THE ENGINEER. THIS WORK IS INCLUDED IN THE "LIGHTING CONTROLLER, RADIO CONTROL, DUPLEX CONSOLE TYPE WITH SCADA" PAY ITEM AND WILL NOT BE PAID FOR SEPARATELY.
 3. AFTER INSTALLATION OF PROPOSED LIGHTING CONTROLLER "X" ON IT'S FOUNDATION, THE UTILITY SERVICE SHALL BE TRANSFERRED TO THE NEW LIGHTING CONTROLLER AND THE EXISTING LOAD CIRCUITS INTERCEPTED AND RECONNECTED TO THE NEW LIGHTING CONTROLLER IN A SINGLE DAY. THIS WORK IS INCLUDED IN THE "LIGHTING CONTROLLER, RADIO CONTROL, DUPLEX CONSOLE TYPE WITH SCADA" PAY ITEM AND WILL NOT BE PAID FOR SEPARATELY.

LOCATE AND RECONNECT EXISTING CABLE, 4 EA. SEE NOTE 3.

3-1/2" No. 350 MCM IN 4" RIGID STEEL CONDUIT IN TRENCH TO EXISTING SERVICE POLE, 300'

NEW CONTROLLER "X" 240/480V, SINGLE PHASE, 3 WIRE. SEE NOTE 1, 2 & 3.

REMOVE EXISTING LIGHTING CONTROLLER

EXISTING CONTROLLER "X"

FILE NAME =	USER NAME = #USER#	DESIGNED -	REVISED -	STATE OF ILLINOIS DEPARTMENT OF TRANSPORTATION	NORTHBOUND SIDE OR I-57 AT U.S. 30		F.A.I. RTE.	SECTION	COUNTY	TOTAL SHEETS	SHEET NO.
#FILE#		DRAWN -	REVISED -		STA. 153+00 (2) TO 166+00 (2) (SOUTHEAST QUADRANT)		157	2008-082L	COOK/WILL	49	34
		CHECKED -	REVISED -		SCALE: 1"=50'-0"	SHEET NO.	OF	SHEETS	STA. 153+00 (2) TO STA. 166+00 (2)	CONTRACT NO. 60F84	
		DATE -	REVISED -		ILLINOIS FED. AID PROJECT						

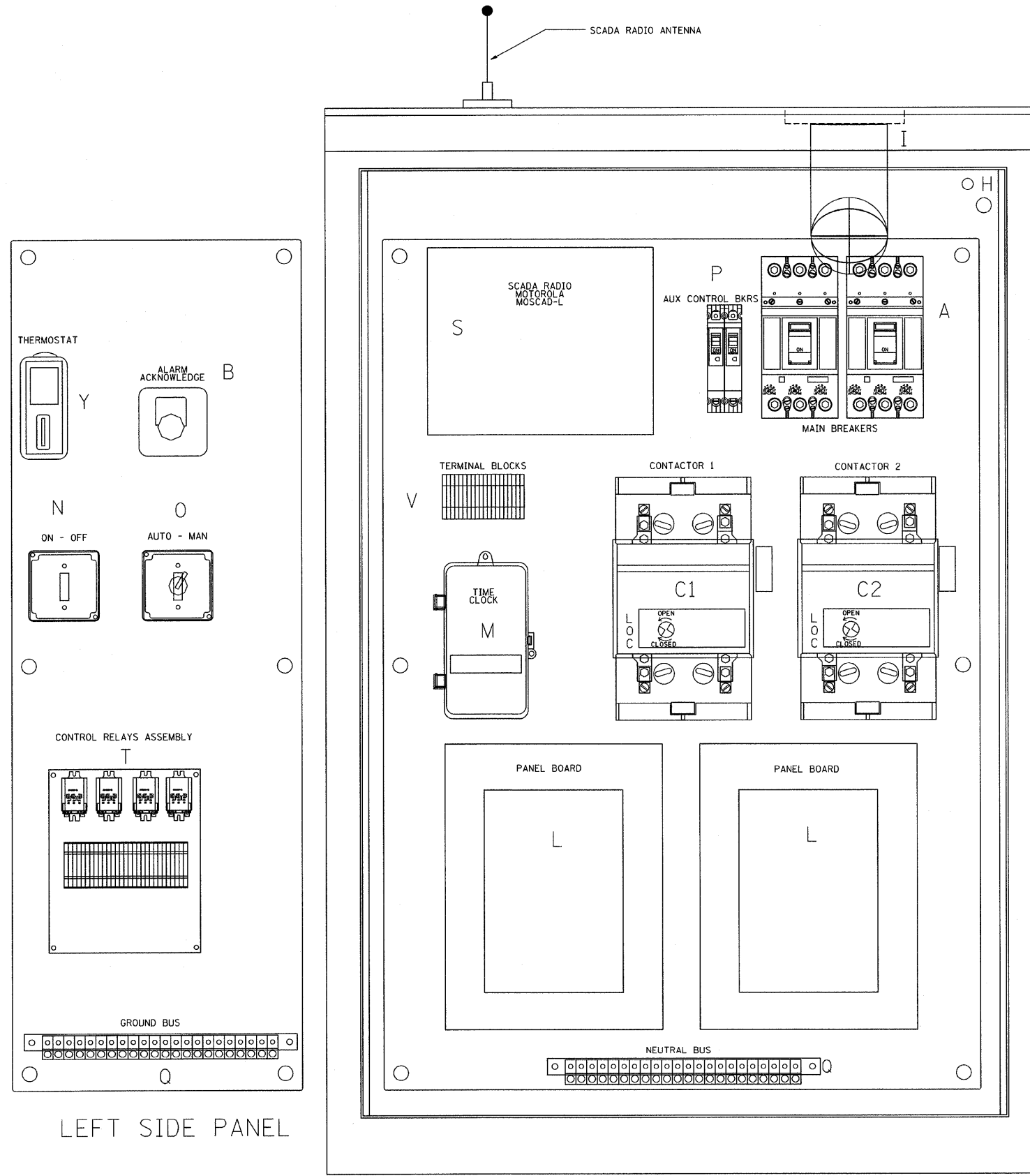

LEFT SIDE PANEL

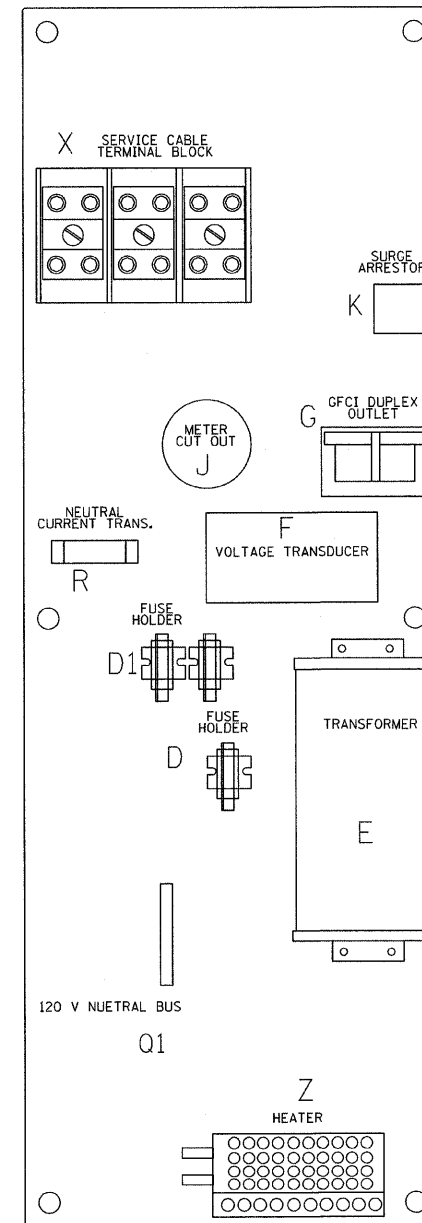

RIGHT SIDE PANEL

BILL OF MATERIALS

ITEM	QTY	DESCRIPTION
A	2	MAIN CIRCUIT BREAKERS 2 POLE 175 AMP WITH AUX CONTACT
B	1	ACKNOWLEDGE SWITCH, PUSH BUTTON WITH YELLOW INSERT
C1, C2*	2	CONTACTOR 2 POLE 200 AMP 240V COIL WITH AUX CONTACTS
D	1	FINGERSAFE FUSE HOLDER WITH KTK-15 FUSE
D1	2	FINGERSAFE FUSE HOLDER WITH KTK-1/2 FUSE
E	1	2.0 KVA 277V-240/120 TRANSFORMER
F	1	VOLTAGE TRANSDUCER WITH COVERED TERMINALS
G	1	15 AMP GFCI DUPLEX OUTLET W/COVER
H	2	DOOR SWITCH
I	1	LIGHT FIXTURE
J	1	METER FITTING 1 PHASE 3 WIRE 200 AMP
K	1	SURGE ARRESTER
L	2	PANEL BOARD 480/240V 1 PHASE, 250 AMP COPPER BUS
M	1	2 CHANNEL DIGITAL TIME CLOCK
N	1	MOMENTARY SWITCH ON - OFF
O	1	SQUARE D, 900IKS11BH13, 2 POSITION SWITCH IN 900IKY1 ENCLOSURE OR APPROVED EQUAL
P	2	BREAKER IP 15A
Q	2	COPPER GROUND AND NEUTRAL BUS 1 x 16 x 1/4
Q1	1	COPPER NEUTRAL BUS WITH 1 #6 AND 8 #12 CONDUCTOR POINTS
R	1	CURRENT TRANSDUCER
S	1	MOTOROLA MOSCAD-L RADIO, 240 V
T*	1	CONTROL RELAY ASSEMBLY 240V COILS WITH 4 3 PDT 25A RELAYS (W389ACX-15) (R1, R2, R3, R4) . QTY 32 TERMINAL BLOCKS
V	20	TERMINAL BLOCKS
X*	1	620 AMP SLPICE BLOCK
Y	1	40-80 DEG THERMOSTAT
Z	1	375 WATT HEATER

* TERMINALS SHALL BE COVERED WITH CLEAR PLEXIGLASS SHEET

FILE NAME = W:\dststd\22x34\be205.dgn	USER NAME = goglienobt	DESIGNED -	REVISED - R. TOMSONS 08-19-04
		DRAWN -	REVISED -
	PLOT SCALE = 50.000' / IN.	CHECKED -	REVISED -
	PLOT DATE = 1/4/2008	DATE -	REVISED -

STATE OF ILLINOIS
DEPARTMENT OF TRANSPORTATION

LIGHTING CONTROLLER, RADIO CONTROL
DUPLEX TYPE WITH SCADA

SCALE: NONE SHEET NO. 1 OF 4 SHEETS STA. TO STA.

F.A. RTE.	SECTION	COUNTY	TOTAL SHEETS	SHEET NO.
157	2008-082L	COOK/WILL	49	35
BE-205			CONTRACT NO. 60F84	
FED. ROAD DIST. NO. 1 [ILLINOIS] FED. AID PROJECT				

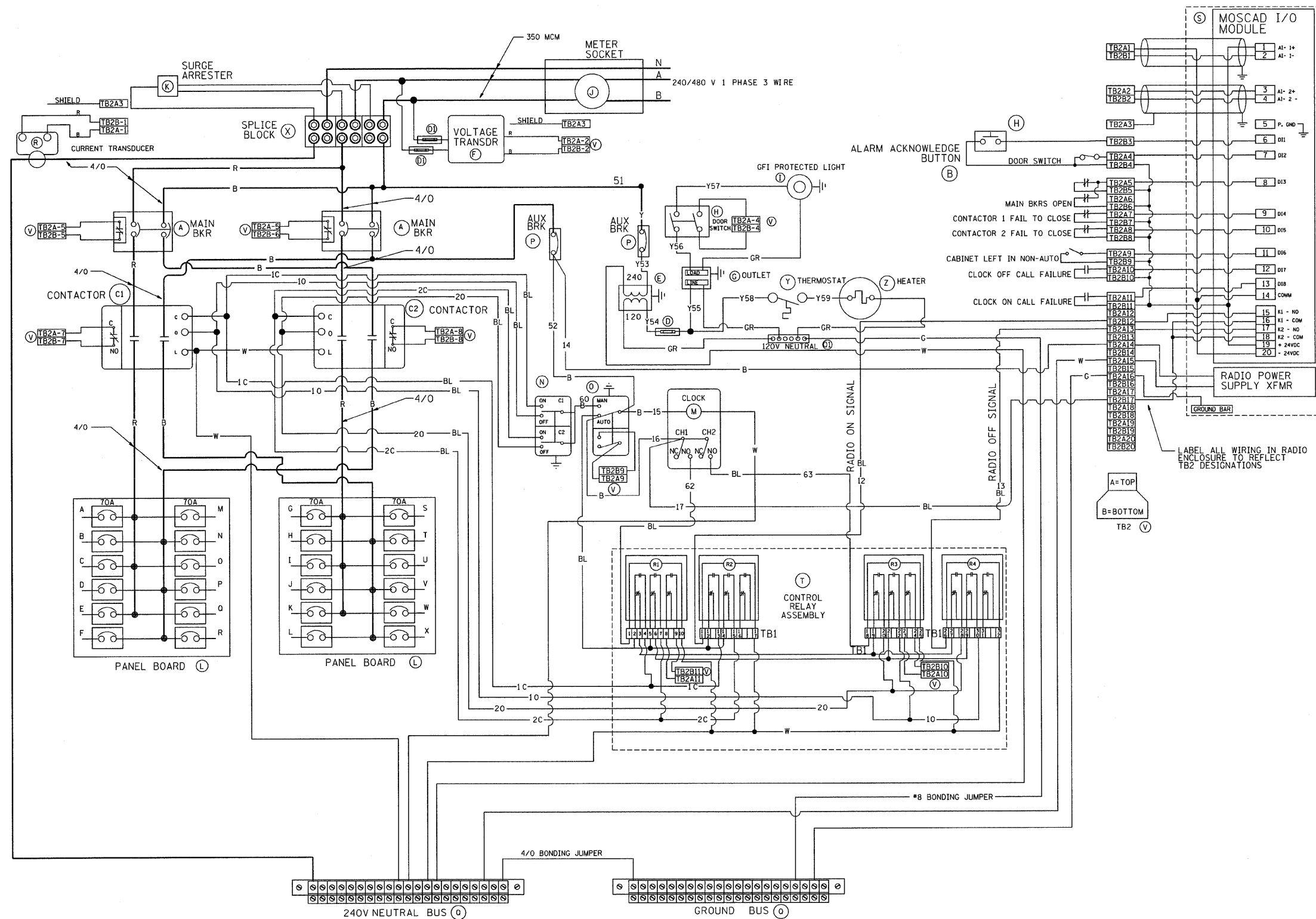

BILL OF MATERIALS		
ITEM #	QTY	DESCRIPTION
A	2	MAIN CIRCUIT BREAKERS 2 POLE 175 AMP WITH AUX CONTACT
B	1	ACKNOWLEDGE SWITCH, PUSH BUTTON WITH YELLOW INSERT
C1, C2	2	CONTACTOR 2 POLE 200 AMP 240V COIL WITH AUX CONTACTS
D	1	FINGERSAFE FUSE HOLDER WITH KTK-10 FUSE
D1	2	FINGERSAFE FUSE HOLDER WITH KTK-1/2 FUSE
E	1	2.0 KVA 277V-240/120 TRANSFORMER
F	1	VOLTAGE TRANSDUCER
G	1	15 AMP GFCI DUPLEX OUTLET W/COVER
H	2	DOOR SWITCH A-20G0-B7-K
I	1	LIGHT FIXTURE
J	1	METER FITTING 1 PHASE 3 WIRE 200 AMP
K	1	SURGE ARRESTER
L	2	PANEL BOARD 480/240V 1 PHASE, 250 AMP COPPER BUS
M	1	2 CHANNEL DIGITAL TIME CLOCK
N	1	MOMENTARY SWITCH ON - OFF
O	1	SQUARE D, 900KSI1B1H3, 2 POSITION SWITCH IN 900IX1 ENCLOSURE
P	2	BREAKER IP 15A
O	2	COPPER GROUND AND NEUTRAL BUS 1 x 16 x 1/4
O1	1	COPPER NEUTRAL BUS WITH 1 I/O AND *6 CONDUCTOR POINTS
R	1	CURRENT TRANSDUCER
S	1	MOTOROLA MOSCAD-L RADIO, 240 V
T	1	CONTROL RELAY ASSEMBLY 240V COILS WITH 4 3 PDT 25A RELAYS (W389ACX-15) (R1, R2, R3, R4) - QTY 32 TERMINAL BLOCKS
V	20	TERMINAL BLOCKS
X	1	620 AMP SPLICE BLOCK
Y	1	40-80 DEG THERMOSTAT
Z	1	375 WATT HEATER

FILE NAME =
W:\dststd\22x34\be205.dgn

USER NAME = gaglianobt
PLOT SCALE = 50.000' / IN.
PLOT DATE = 1/4/2008

DESIGNED -
DRAWN -
CHECKED -
DATE -

REVISED - R. TOMSONS 08-19-04
REVISED -
REVISED -
REVISED -

**STATE OF ILLINOIS
DEPARTMENT OF TRANSPORTATION**

**LIGHTING CONTROLLER, RADIO CONTROL
DUPLEX TYPE WITH SCADA**

SCALE: NONE SHEET NO. 2 OF 4 SHEETS STA. TO STA.

F.A. RTE.	SECTION	COUNTY	TOTAL SHEETS	SHEET NO.
IS712008-082L		COOK/MILL	49	36
BE-205			CONTRACT NO. 60884	
FED. ROAD DIST. NO. 1 [ILLINOIS] FED. AID PROJECT				

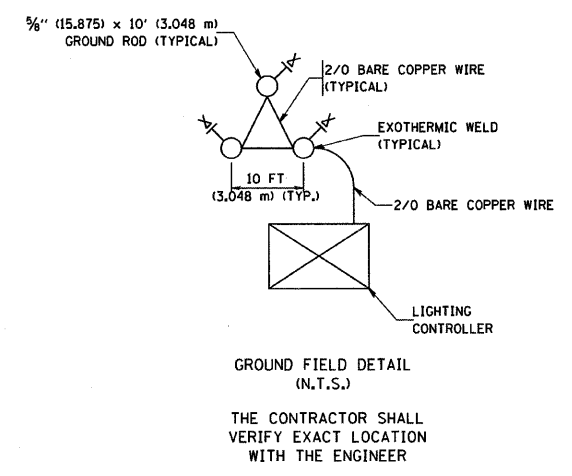
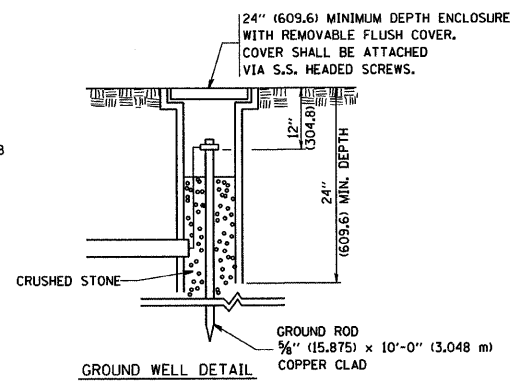
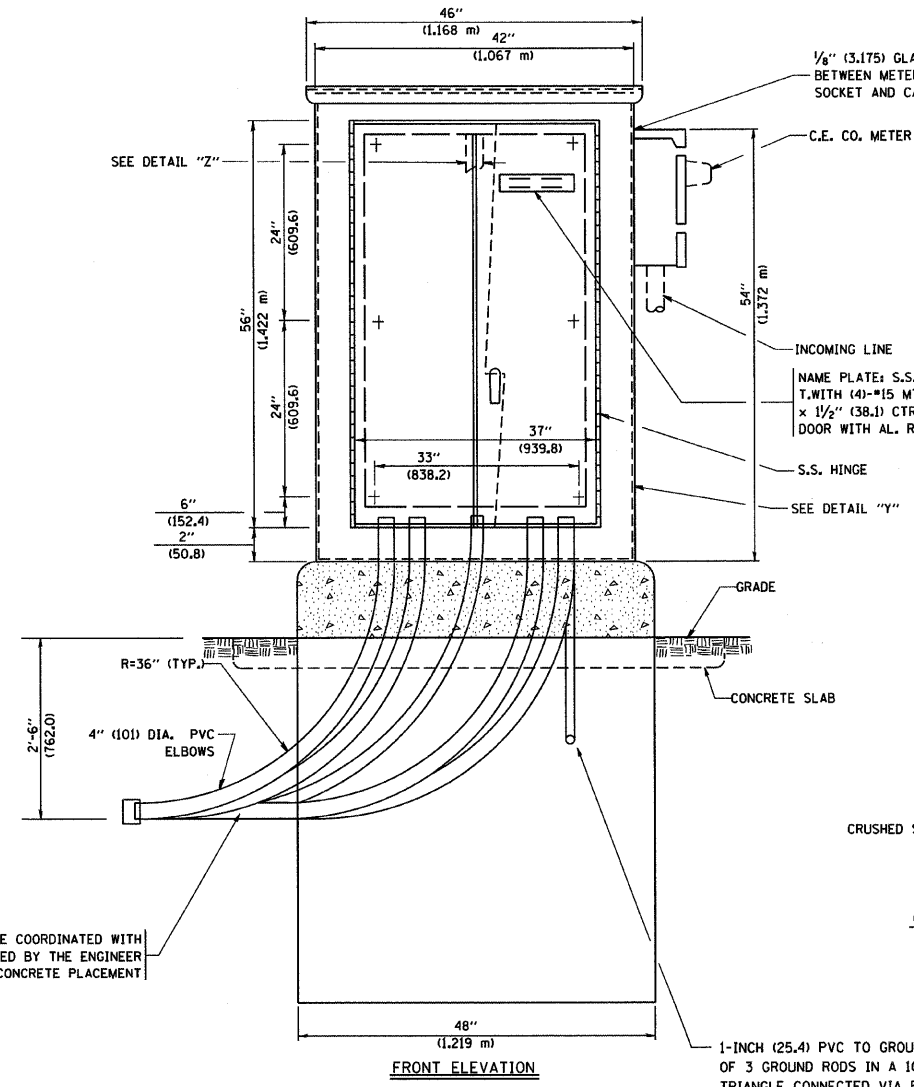
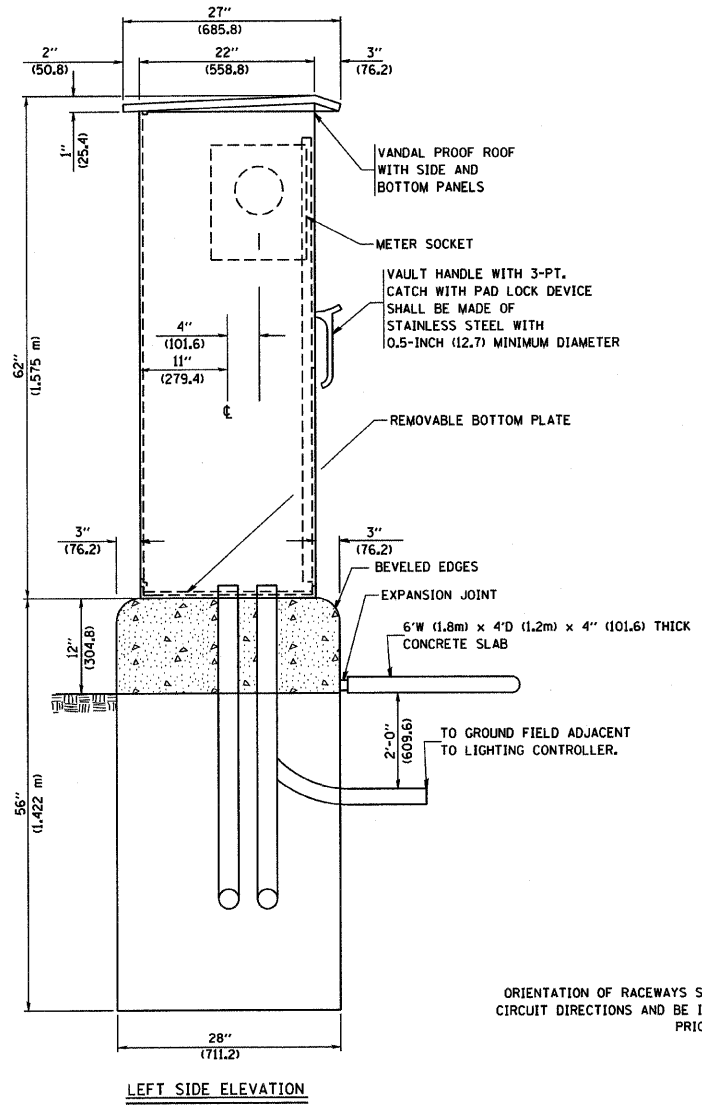
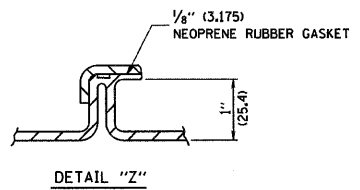
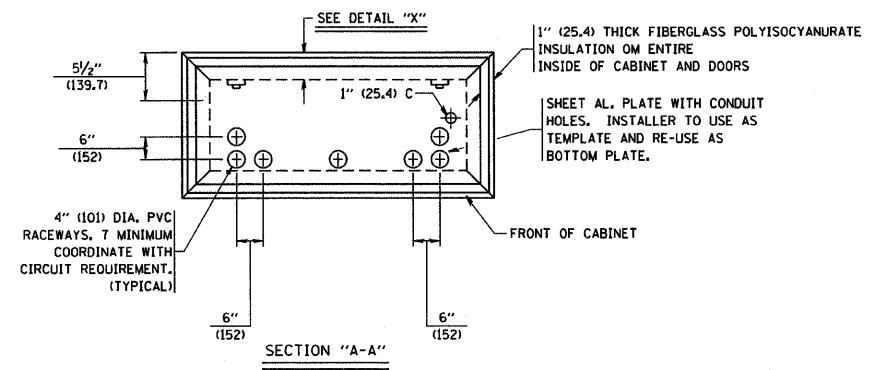
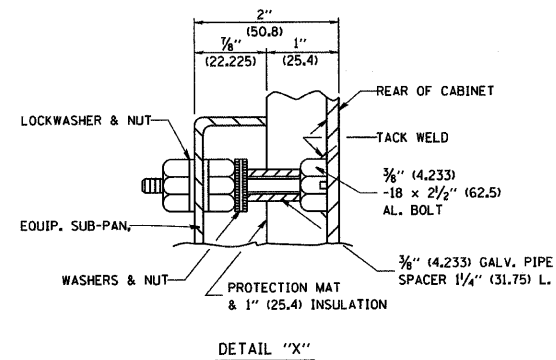
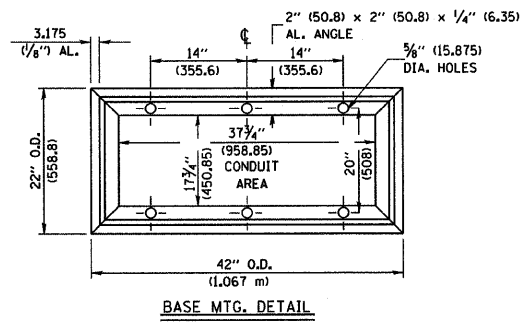
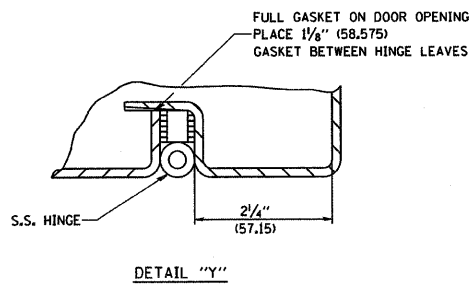

ORIENTATION OF RACEWAYS SHALL BE COORDINATED WITH CIRCUIT DIRECTIONS AND BE INSPECTED BY THE ENGINEER PRIOR TO CONCRETE PLACEMENT

1-INCH (25.4 mm) PVC TO GROUND FIELD OF 3 GROUND RODS IN A 10 FT (3,048 mm), TRIANGLE CONNECTED VIA BARE COPPER WIRE. VERIFY EXACT LOCATION OF GROUND FIELD WITH THE ENGINEER. NO GROUND WELL SHALL BE PLACED IN CONCRETE PAD IN FRONT OF CONTROLLER.

FILE NAME = W:\dststd\22x34\be205.dgn	USER NAME = gaglianobt	DESIGNED - DRAWN -	REVISED - REVISED -	DESIGNED - DRAWN -	REVISED - REVISED -	DESIGNED - DRAWN -	REVISED - REVISED -	DESIGNED - DRAWN -	REVISED - REVISED -	DESIGNED - DRAWN -	REVISED - REVISED -
PLOT SCALE = 50,000' / IN. PLOT DATE = 1/4/2008				STATE OF ILLINOIS DEPARTMENT OF TRANSPORTATION				LIGHTING CONTROLLER, RADIO CONTROL DUPLIX TYPE WITH SCADA			
SCALE: NONE				SHEET NO. 3 OF 4 SHEETS STA. TO STA.				F.A. RTE. SECTION COUNTY TOTAL SHEETS SHEET NO. 157 2008-082L COOK/WILL 49 37 BE-205 CONTRACT NO. 6084 FED. ROAD DIST. NO. 1 [ILLINOIS] FED. AID PROJECT			

NOTES

1. CABINET SHALL BE FABRICATED FROM 0.125-INCH (3.175) SHEET ALUMINUM #3003H14, FORMED AND ARC WELDED.
2. ALL SCREWS AND HARDWARE SHALL BE PLATED, GALVANIZED, OR MADE OF BRASS, ALUMINUM OR STAINLESS STEEL, UNLESS OTHERWISE NOTED.
3. NAME PLATE SHALL HAVE ENGRAVED 0.75-INCH (19.05) HIGH LETTERS FILLED IN BLACK: "STATE OF ILLINOIS LIGHTING CONTROLS" UNLESS OTHERWISE SPECIFIED.
4. ONE INCH THICK POLYISOCYANURATE INSULATION SHALL BE INSTALL AND PERMANENTLY CEMENTED ON ALL SIDES OF THE CABINET AND DOORS.
5. CABINET SHALL BE PRIMED AND PAINTED AS SPECIFIED.
6. ELECTRIC UTILITY METER BOX SHALL BE MOUNTED ON THE SIDE OF CONTROL CABINET AS SHOWN ON THE PANEL LAYOUT DIAGRAM.
7. THE COMPLETED CONTROLLER SHALL BE U.L. LISTED AS AN INDUSTRIAL CONTROL PANEL UNDER UL508.
8. METAL MOUNTING PANEL SHALL BE FABRICATED FROM THE SAME MATERIAL AS THE CABINET AND SHALL BE FLANGED BACK 0.75-INCHES I.D. ON 4 SIDES.
9. CIRCUIT BREAKERS AND CONTACTORS AND OTHER COMPONENTS SHALL BE MOUNTED ON 0.125-INCH (3.175) THICK GLASTIC INSULATION BACK PANEL.
10. ALL DEVICES SHALL BE FRONT REMOVABLE.
11. TIME CLOCK CHANNEL 1 N.O. CONTACT IS CLOSED NIGHT AND OPEN DAY (LIGHTS ON).
12. SET LATITUDE TO 42 DEGREES. SET CH.1 TO 25 MINUTES AFTER ASTRONOMICAL SUNSET, 40 MINUTES BEFORE ASTRONOMICAL SUNRISE. SET CH.2 TO 60 MINUTES AFTER ASTRONOMICAL SUNSET (WITH A SIGNAL LENGTH OF 1 SECOND), +20 MINUTES AFTER ASTRONOMICAL SUNRISE (WITH A SIGNAL LENGTH OF 7 SECONDS.)
13. BUS BAR SHALL HAVE 22 LUG TERMINALS SIZED TO ACCOMMODATE REQUIRED WIRE SIZES. 240V NEUTRAL BUS SHALL BE PAINTED WHITE, GROUND BUS SHALL BE PAINTED GREEN, AND THE 120V NEUTRAL BUS SHALL BE PAINTED GREY.
14. ALL LUGS SHALL BE OF COPPER SCREWS AND CONNECTORS, SPRING HELD.
15. ALL WIRING TERMINATIONS SHALL BE RATED NOT LESS THAN 75 DEGREE CENTIGRADE.
16. ALL CONTROL WIRING SHALL BE 600V #12 TYPE MTW.
17. ALL POWER WIRING SHALL BE 600V TYPE RHH/RHW.
18. ALL WIRING WITHIN THE CABINET SHALL BE COLOR CODED AS INDICATED:

R - RED	Y - YELLOW
B - BLACK	W - WHITE
BL - BLUE	G - GREEN
	GR - GREY
19. MOSCAD I/O WIRING SHALL BE:
 DIGITAL INPUT (DI) WIRING SHALL BE #16 MTW PURPLE.
 ANALOG INPUT (AI) WIRING SHALL BE #18, 2/C SHIELDED.
 AI AND DI WIRING MAY BE BUNDLED TOGETHER, BUT SHALL NOT BE BUNDLED WITH OTHER WIRING.
20. ALL DIMENSIONS ARE IN INCHES (MILLIMETERS) UNLESS OTHERWISE INDICATED.
21. SCHEMATIC SHOWN WITH BREAKER OPEN, CONTACTOR OPEN, CABINET DOOR CLOSED, CLOCK NOT ACTIVE (DE-ENERGIZED STATE).
22. A LAMINATED COPY OF THE CIRCUIT SCHEMATIC AND SCADA I/O DIAGRAM (NO SMALLER THAN 11"x17" EACH) SHALL BE ATTACHED TO THE INSIDE OF THE CONTROLLER WITH STAINLESS STEEL SCREWS.

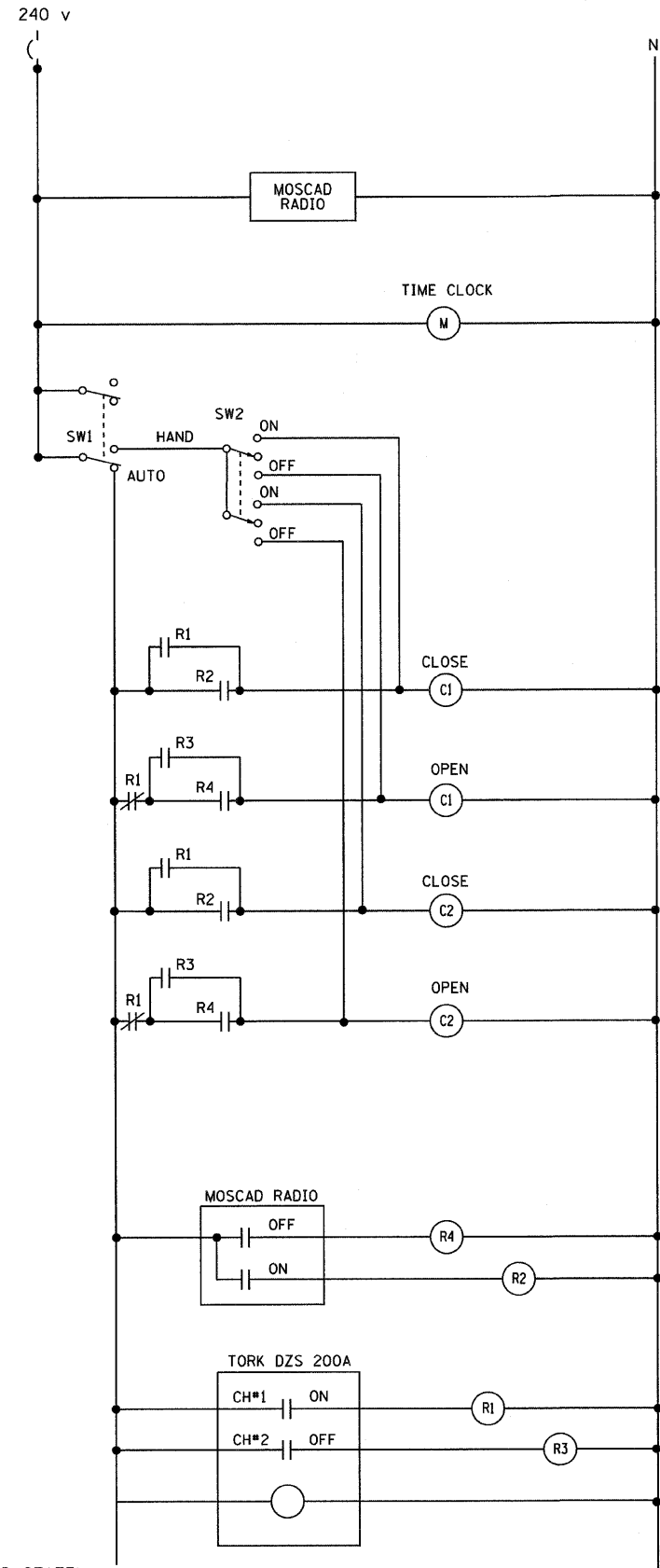

CONTROL CIRCUIT LADDER LOGIC DIAGRAM

MOSCAD I/O ASSIGNMENTS		
TERM	MOSCAD DESTINATION	DESCRIPTION OF INPUT
1	ANALOG INPUT 1 (+)	CABINET NEUTRAL CURRENT
2	ANALOG INPUT 1 (-)	CABINET NEUTRAL CURRENT
3	ANALOG INPUT 2 (+)	CABINET SERVICE VOLTAGE
4	ANALOG INPUT 2 (-)	CABINET SERVICE VOLTAGE
5	P. GROUND	GROUND
6	DIGITAL INPUT 1	ALARM KNOWLEDGE
7	DIGITAL INPUT 2	DOOR OPEN
8	DIGITAL INPUT 3	MAINSI BREAKER OPEN
9	DIGITAL INPUT 4	CONTACTOR 1 OPEN
10	DIGITAL INPUT 5	CONTACTOR 2 OPEN
11	DIGITAL INPUT 6	CABINET IN NON-AUTO
12	DIGITAL INPUT 7	BACK-UP CLOCK OFF CALL
13	DIGITAL INPUT 8	BACK-UP CLOCK ON CALL
14	DI COMMON	COMMON
15	K1 NO	LIGHTS ON CALL
16	K1 C	K1 COMMON
17	K2 NO	LIGHTS OFF CALL
18	K2 C	K2 COMMON
19	24 V+	24+VDC
20	24 V-	24-VDC

ALL ANALOG INPUTS WILL BE 4-20 MA ONLY. DIGITAL OUTPUT RELAYS WILL BE ELECTRICALLY ENERGIZED AND MOMENTARILY HELD
 MIXED I/O MODULE MODEL NUMBER V436

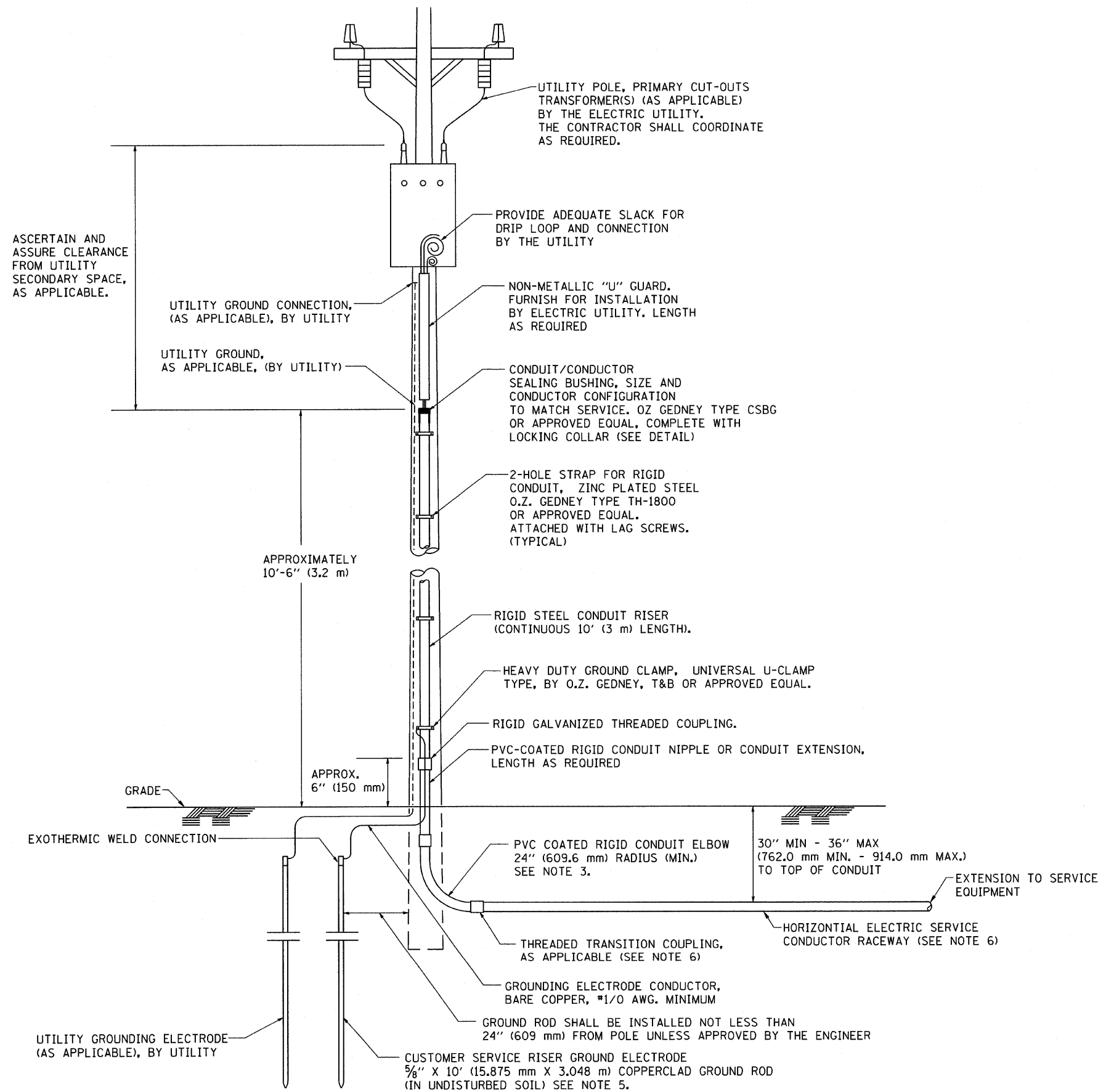

APPLICATION

THIS DETAIL APPLIES FOR LOW VOLTAGE ELECTRIC SERVICE (660 V OR LESS) FROM AN OVERHEAD UTILITY SUPPLY TO SEPERATLY-MOUNTED SERVICE EQUIPMENT.

NOTES

- SERVICE VOLTAGE SHALL BE AS INDICATED ELSEWHERE IN THE DRAWINGS.
- UNLESS OTHERWISE INDICATED, ITEMS AND WORK SHALL BE INCLUDED AND PAID AS PART OF THE ELECTRIC UTILITY SERVICE INSTALLATION PAY ITEM.
- CONDUIT AND CONNECTOR DIAMETER SHALL MATCH THE DIAMETER OF THE SERVICE CONDUCTOR RACEWAY AS INDICATED ON THE PLANS.
- PVC COATED RACEWAYS AND ACCESSORIES SHALL BE CAREFULLY INSTALLED WITH MFR RECOMMENDED TOOLS AND PROCEDURES TO AVOID DAMAGE. ANY DAMAGE SHALL BE REPAIRED WITH COMPATIBLE PVC TOUCH-UP MATERIAL TO THE SATISFACTION OF THE ENGINEER OR THE DAMAGED MATERIAL SHALL BE REPLACED AT NO ADDITIONAL COST.
- THE CONTRACTOR SHALL OBTAIN INSPECTION AND APPROVAL BY THE ENGINEER OF SERVICE RISER GROUND ELECTRODE, RISER ELBOW, NIPPLE AND CONNECTION TO SERVICE CONDUCTOR RACEWAY EXTENSION BEFORE BACKFILL AND SHALL ALSO OBTAIN INSPECTION OF SERVICE RISER AND SEALING BUSHING BEFORE UTILITY "U" GUARD INSTALLATION AND SERVICE CONNECTION.
- THE HORIZONTAL ELECTRIC SERVICE CONDUCTOR RACEWAY SHALL BE AS INDICATED AND SHALL BE MEASURED SEPARATELY FOR PAYMENT. WHEN THE RACEWAY IS PVC-COATED RIGID GALVANIZED STEEL, THE COUPLING SHALL BE THE SAME. WHEN THE RACEWAY IS PVC CONDUIT (IN CONCRETE), THE COUPLING SHALL BE A METALIC TO NON METALIC ADAPTER. WHEN THE RACEWAY IS ENCASED IN CONCRETE, THE CONCRETE SHALL EXTEND TO COVER THE COUPLING.
- PLANS AND DETAILS INDICATE THE GENERAL NATURE AND REQUIREMENTS. THEY DO NOT SHOW EVERY ACCESSORY AND ATTACHMENT, AND THEY DO NOT RELIEVE THE CONTRACTOR OF THE REQUIREMENTS OF THE SPECIFICATIONS AND SPECIAL PROVISIONS TO ASCERTAIN UTILITY REQUIREMENTS AND TO COORDINATE ACCORDINGLY, FURNISHING ALL ITEMS AND WORK NOT PROVIDED BY THE UTILITY, BUT NECESSARY FOR A COMPLETE SERVICE INSTALLATION IS REQUIRED AND SHALL BE INCLUDED IN THE ELECTRIC UTILITY SERVICE INSTALLATION PAY ITEM.

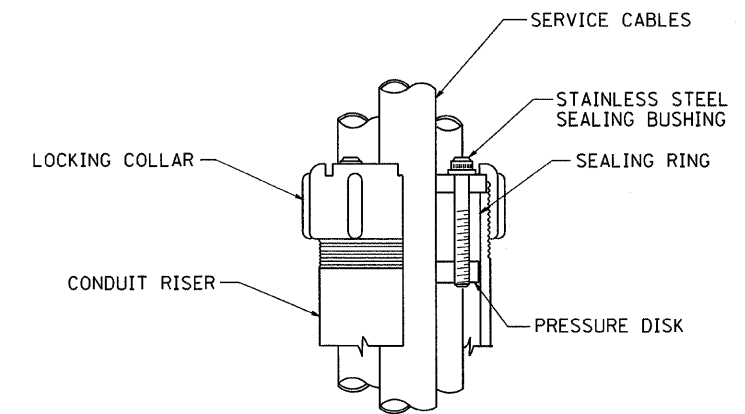

SEALING BUSHING DETAIL

FILE NAME = W:\d\std\22x34\be220.dgn	USER NAME = gogienobt	DESIGNED -	REVISED - 03-03-06	STATE OF ILLINOIS DEPARTMENT OF TRANSPORTATION	ELECTRIC SERVICE INSTALLATION AERIAL REMOTE DISCONNECT			F.A. RTE.	SECTION	COUNTY	TOTAL SHEETS	SHEET NO.
	PLOT SCALE = 50.0000' / IN.	DRAWN -	REVISED -		IS7	2008-082L	COOK/WILL	49	39			
	PLOT DATE = 1/4/2008	CHECKED - MEA	REVISED -		BE-220	CONTRACT NO. 60F84						
		DATE -	REVISED -		FED. ROAD DIST. NO. 1 ILLINOIS FED. AID PROJECT							
					SCALE: NONE	SHEET NO. 1 OF 1 SHEETS	STA.	TO STA.				

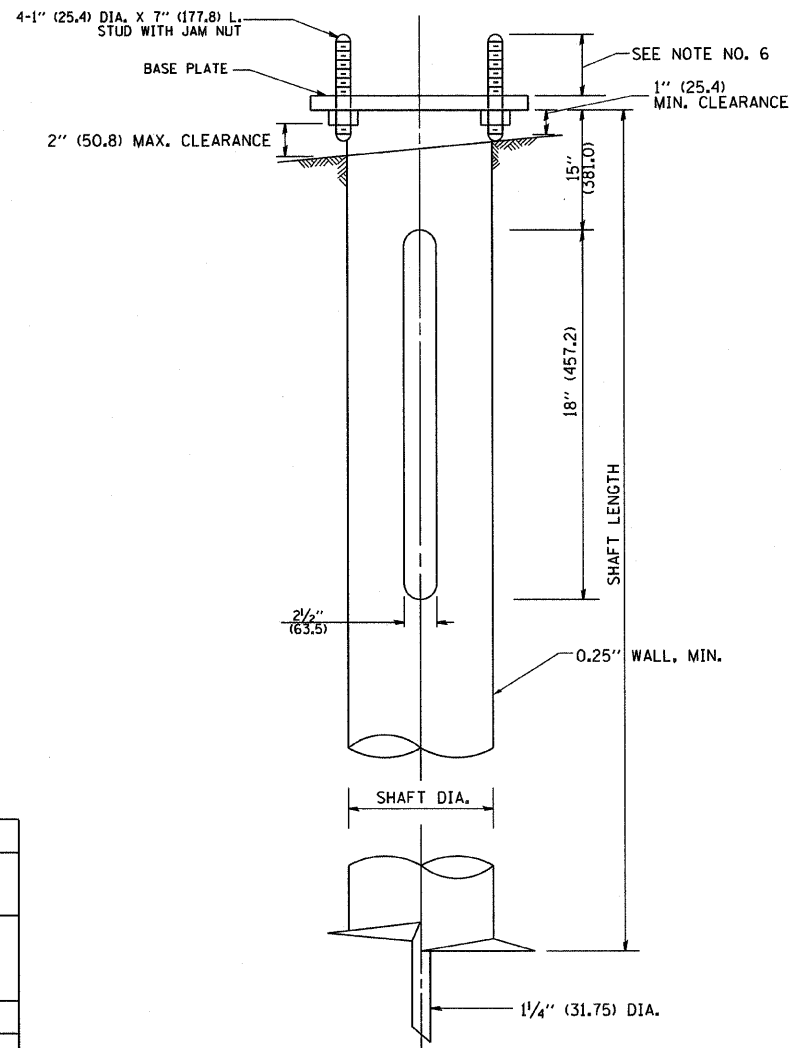
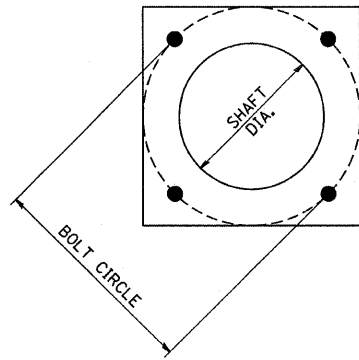

HELIX FOUNDATION SIZE

POLE MOUNTING HEIGHT	BOLT CIRCLE	SHAFT DIAMETER	SHAFT LENGTH	BASEPLATE
30 FT.	1 1/2"	8 5/8"	6 FT.	12"x12"x1"
31 FT.-35 FT.	1 1/2"	8 5/8"	6 FT.	12"x12"x1"
36 FT.-40 FT.	15"	8 5/8"	6 FT.	15"x15"x1 1/4"
41 FT.-45 FT.	15"	8 5/8"	6 FT.	15"x15"x1 1/4"
46 FT.-50 FT.	15"	10"	8 FT.	15"x15"x1 1/4"

METAL HELIX FOUNDATION MATERIALS

ITEM	MATERIAL REQUIREMENT
BASEPLATE	AASHTO M 270M, GRADE 36 (M270M, GRADE 250)
SHAFT	ASTM A 252, GRADE 2 (PHOSPHOROUS 0.04% MAXIMUM, SULFUR 0.05% MAXIMUM)
HELIX SCREW	AASHTO M 183 (ASTM A 635)
PILOT POINT	AASHTO M 270 (ASTM A 575)
ANCHOR RODS/STUDS	AASHTO M 314 (ASTM F 1554)
HEXAGON NUTS	AASHTO M 291M (ASTM A 563) GRADE DH, OR AASHTO M 292 (ASTM A 194) GRADE 2H
WASHERS	AASHTO M 293 (ASTM F 436)

NOTES:

- ALL DIMENSION IN INCHES (MILLIMETERS) UNLESS OTHERWISE SHOWN.
- ALL MATERIAL SHALL BE GALVINIZED ACCORDING TO AASHTO M111, UNLESS OTHERWISE SPECIFIED.
- ALL WELDS SHALL BE CONTINUOUS AND NOT LESS THAN 1/4" (6.35 mm) FILLET WELDS. THE WELDED FOUNDATION SHALL BE CAPABLE OF WITHSTANDING 10,000 FT/LBS (13558.18 n.m) OF INSTALLATION TORQUE APPLIED ABOUT THE AXIS OF THE FOUNDATION.
- THE HELIX FOUNDATION SHAFT SHALL BE INSTALLED VERTICAL AND THE BASE PLATE SHALL BE IN LEVEL. THE BREAKAWAY COUPLINGS AND HARDWARE SHALL NOT BE USED TO ALIGN THE POLE INSTALLATION.
- THE CABLE TRENCH SHALL BE BACKFILLED AND FIRMLY COMPACTED BEFORE THE INSTALLATION OF THE LIGHT POLE.
- THE CONTRACTOR SHALL COORDINATE EXTENSION OF ANCHOR BOLTS ABOVE TOP OF THE BASE PLATE WITH THE BREAKAWAY DEVICE MANUFACTURER'S REQUIREMENTS.
- ANY VOIDS WITHIN THE METAL FOUNDATION SHALL BE FILLED WITH FINE AGGREGATE.
- METAL FOUNDATIONS SHALL BE INSTALLED IN UNDISTURBED SOIL. PREDRILLING A PILOT HOLE AND/OR BACKFILLING AROUND THE FOUNDATION IS NOT ALLOWED.
- THE METAL FOUNDATION SHALL NOT BE INSTALLED TO A TORQUE WHICH EXCEEDS THE MANUFACTURER'S MAXIMUM TORQUE RATING NOR SHALL IT BE INSTALLED TO AN INSTALLATION TORQUE VALUE OF LESS THAN 3,500 FT LB (4,750 KNM). METAL FOUNDATIONS THAT ARE NOT INSTALLED TO FULL INSTALLATION DEPTH OR DO NOT ACHIEVE THE MINIMUM INSTALLATION TORQUE SHALL BE REMOVED AND REPLACED WITH A CONCRETE FOUNDATION AT NO ADDITIONAL COST.
- THE BASEPLATE SHALL BE PERPENDICULAR TO THE SHAFT AXIS ($\pm 1^\circ$) AND THE HOLE CENTERLINE SHALL BE CONCENTRIC (± 0.188) TO THE SHAFT AXIS.
- THE PILOT POINT AND SHAFT AXIS SHALL BE CONCENTRIC (± 0.125) AND IN LINE ($\pm 2^\circ$).
- THE BASEPLATE SHALL BE STAMPED WITH THE MANUFACTURERS NAME AND DATE OF MANUFACTURE.

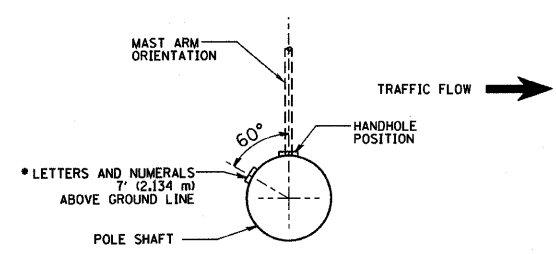

POSITION OF HANDHOLE AND POLE NUMBER FOR SINGLE MAST ARM POLES MOUNTED ON BRIDGE PARAPET OR BARRIER WALL

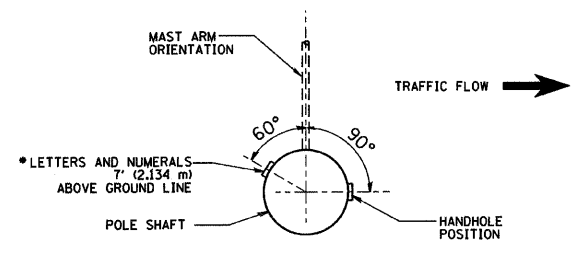

POSITION OF HANDHOLE AND POLE NUMBER FOR SINGLE MAST ARM POLES

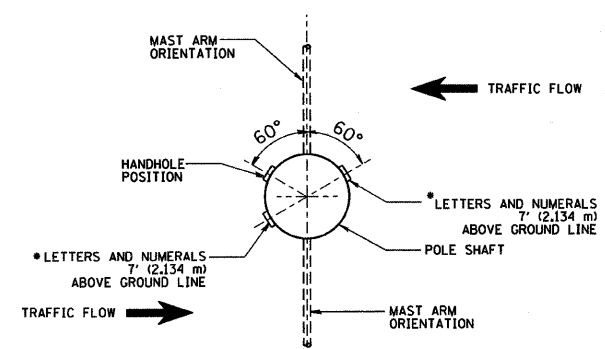

POSITION OF HANDHOLE AND POLE NUMBER FOR TWIN MAST ARM POLES

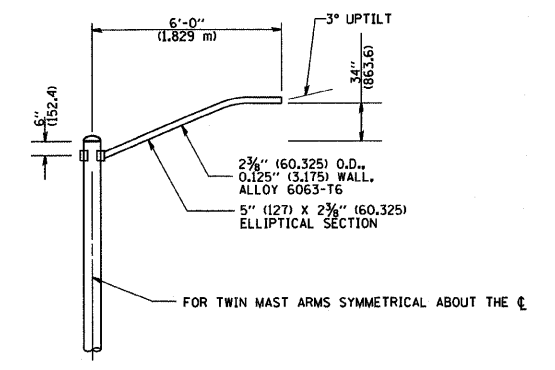
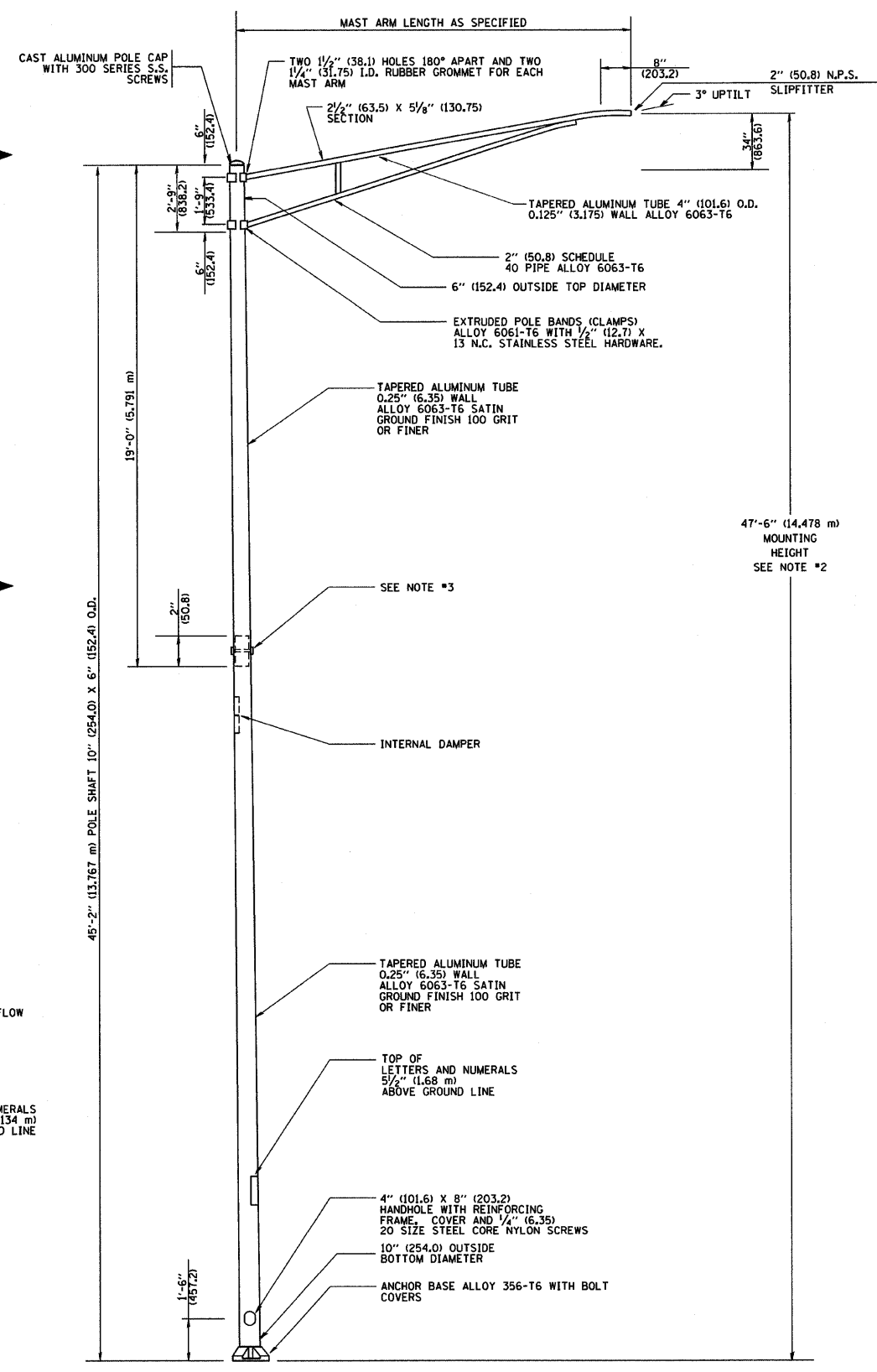

6' (1.8 m) SINGLE MEMBER MAST ARM (N.T.S.)

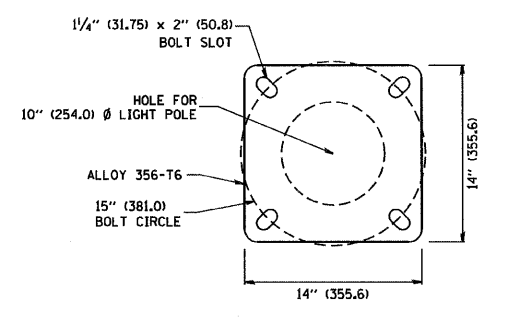

LIGHT POLE BASE PLATE DETAIL
15 INCH (381.0) BOLT CIRCLE

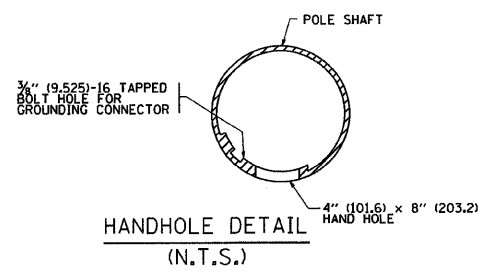

HANDHOLE DETAIL (N.T.S.)

- NOTES:
1. ALL DIMENSIONS ARE IN INCHES (MILLIMETERS) UNLESS OTHERWISE SHOWN.
 2. MOUNTING HEIGHT IS DEFINED AS THE DISTANCE FROM THE CENTERLINE OF THE TENON TO THE BOTTOM OF THE ANCHOR BASE.
 3. TWO PIECE SHAFT WILL BE MATCHED MARKED AND INTERCHANGEABLE BETWEEN DIFFERENT UNITS. FIELD DRILLING OF THE HOLES WILL NOT BE ALLOWED.
 4. THE LIGHT POLE WILL MEET AASHTO DESIGN CRITERIA AS SPECIFIED.
 5. THE INSTALLING CONTRACTOR WILL PROVIDE A UL LISTED GROUNDING CONNECTOR, BURNDY K2C2S, T&B SP4DL OR APPROVED EQUAL.
 6. LIGHT POLES WILL NOT BE INSTALLED WITHOUT MAST ARMS AND LUMINAIRES.
 7. LIGHT POLES WILL BE SET PLUMB ON THE FOUNDATION WITHOUT THE USE OF LEVELING NUTS, WASHERS OR SHIMS.
 8. LIGHTING UNIT IDENTIFICATION NUMBERS SHALL BE INSTALLED BEFORE THE LIGHTING UNIT IS ENERGIZED.

FILE NAME = W:\dststd\22x34\ba400.dgn	USER NAME = goglianob	DESIGNED -	REVISED - R. TOMSONS 09-06-00	STATE OF ILLINOIS DEPARTMENT OF TRANSPORTATION	ALUMINUM LIGHT POLE		F.A. RTE.	SECTION	COUNTY	TOTAL SHEETS	SHEET NO.
		DRAWN -	REVISED - R. TOMSONS 09-03-03		47'-6" (14.478 m) MOUNTING HEIGHT		IS7	2008-082L	Cook/WILL	49	41
		PLOT SCALE = 50,000' / IN.	CHECKED -			SCALE: NONE	SHEET NO. 1 OF 1 SHEETS	STA.	TO STA.	CONTRACT NO. 60F84	
		PLOT DATE = 1/4/2008	DATE -			FED. ROAD DIST. NO. 1 ILLINOIS FED. AID PROJECT					

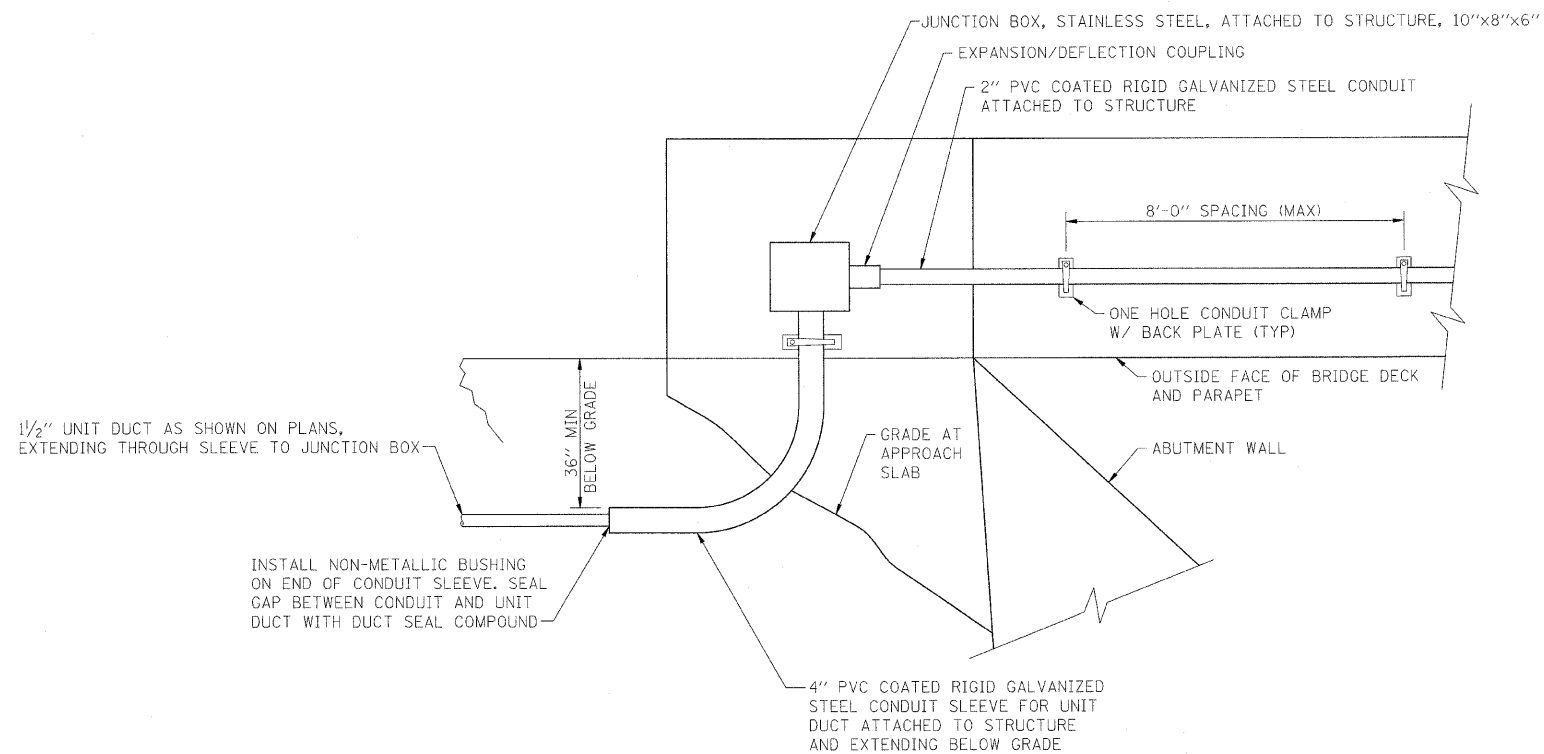

- NOTES:
1. TYPICAL OF FOUR (4) LOCATIONS AT BRIDGES OVER OLD PLANK ROAD TRAIL, SEE PLAN SHEET 32.
 2. ALL MOUNTING AND INSTALLATION HARDWARE FOR PVCC RGS MUST BE PVC COATED.

FILE NAME =	USER NAME = #USER#	DESIGNED -	REVISED -	STATE OF ILLINOIS DEPARTMENT OF TRANSPORTATION	CONDUIT AND JUNCTION BOX ATTACHED TO BRIDGE STRUCTURE DETAIL	F.A.I. RTE.	SECTION	COUNTY	TOTAL SHEETS	SHEET NO.	
#FILE#		DRAWN -	REVISED -			157	2008-082L	COOK/WILL	49	42	
	PLOT SCALE = #SCALE#	CHECKED -	REVISED -			CONTRACT NO. 60F84					
	PLOT DATE = #DATE#	DATE -	REVISED -			ILLINOIS FED. AID PROJECT					
					SCALE: NONE	SHEET NO. OF SHEETS		STA.	TO STA.		

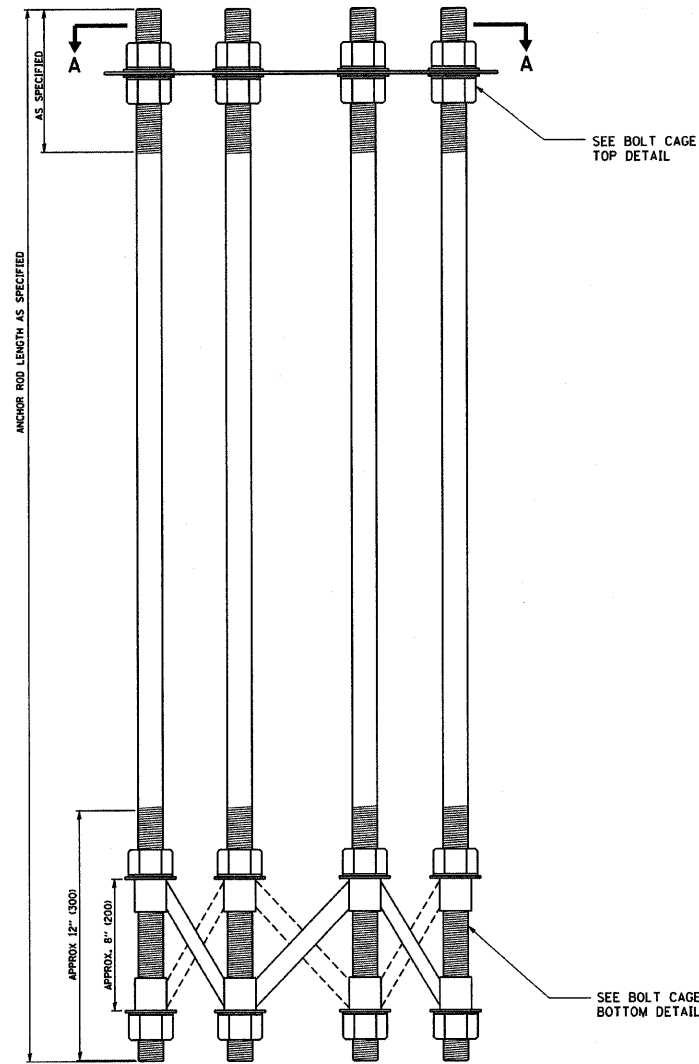

ANCHOR BOLT CAGE

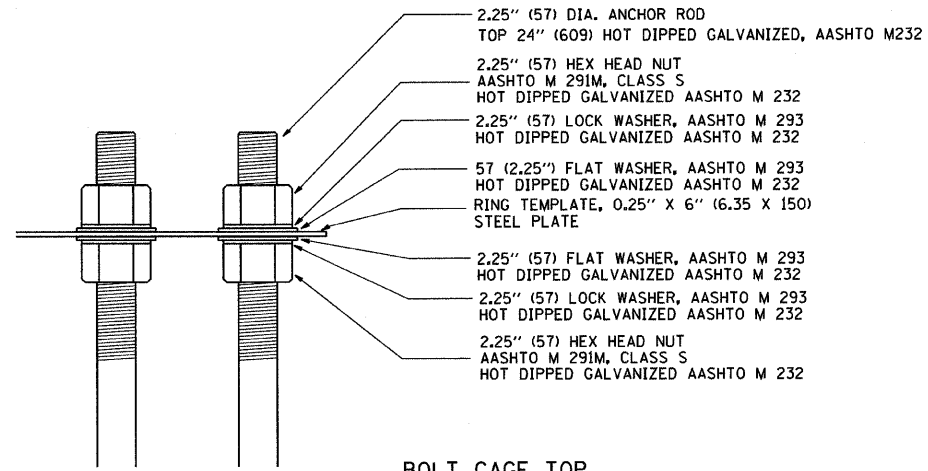

BOLT CAGE TOP

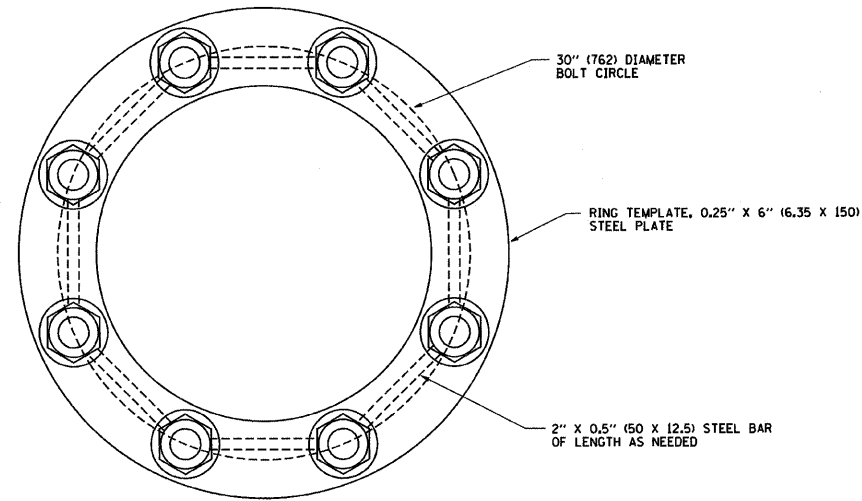

SECTION A-A

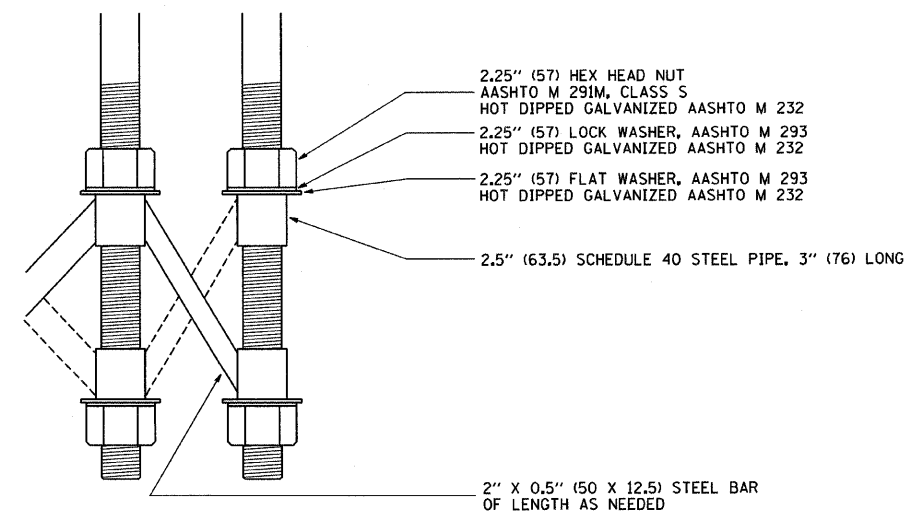

BOLT CAGE BOTTOM

NOTES

1. ALL DIMENSIONS IN INCHES (MILLIMETERS) UNLESS OTHERWISE SHOWN
2. ANCHOR RODS SHALL BE STRAIGHT AND SHALL BE ACCORDING TO AASHTO M 314 OR ASTM F1554, GRADE 725 (GRADE 105) AND GALVANIZED ACCORDING TO ARTICLE 1006.09.
3. ANCHOR ROD INFORMATION SHALL BE SUBMITTED FOR APPROVAL AND SHALL BE FULLY COORDINATED WITH TOWER MANUFACTURERS REQUIREMENTS.

FILE NAME = W:\diststd\22x34\be501.dgn	USER NAME = gogliobt	DESIGNED -	REVISED - R. TOMSONS 04-22-02
		DRAWN -	REVISED -
	PLOT SCALE = 50.000' / IN.	CHECKED -	REVISED -
	PLOT DATE = 1/4/2008	DATE -	REVISED -

**STATE OF ILLINOIS
DEPARTMENT OF TRANSPORTATION**

HIGH MAST LIGHT TOWER		F.A. RTE.	SECTION	COUNTY	TOTAL SHEETS	SHEET NO.
90 FT TO 120 FT (27 m TO 36 m) FOUNDATION DETAIL		157	2008-0821	COOK/WILL	49	44
SCALE: NONE		SHEET NO. 2 OF 2 SHEETS		STA.	TO STA.	
		FED. ROAD DIST. NO. 1 (ILLINOIS) FED. AID PROJECT		CONTRACT NO. 60F821		

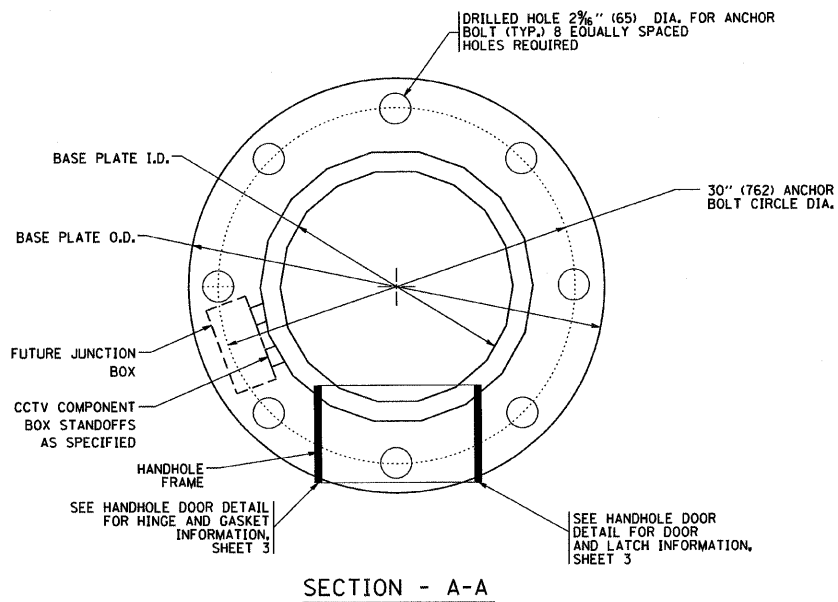
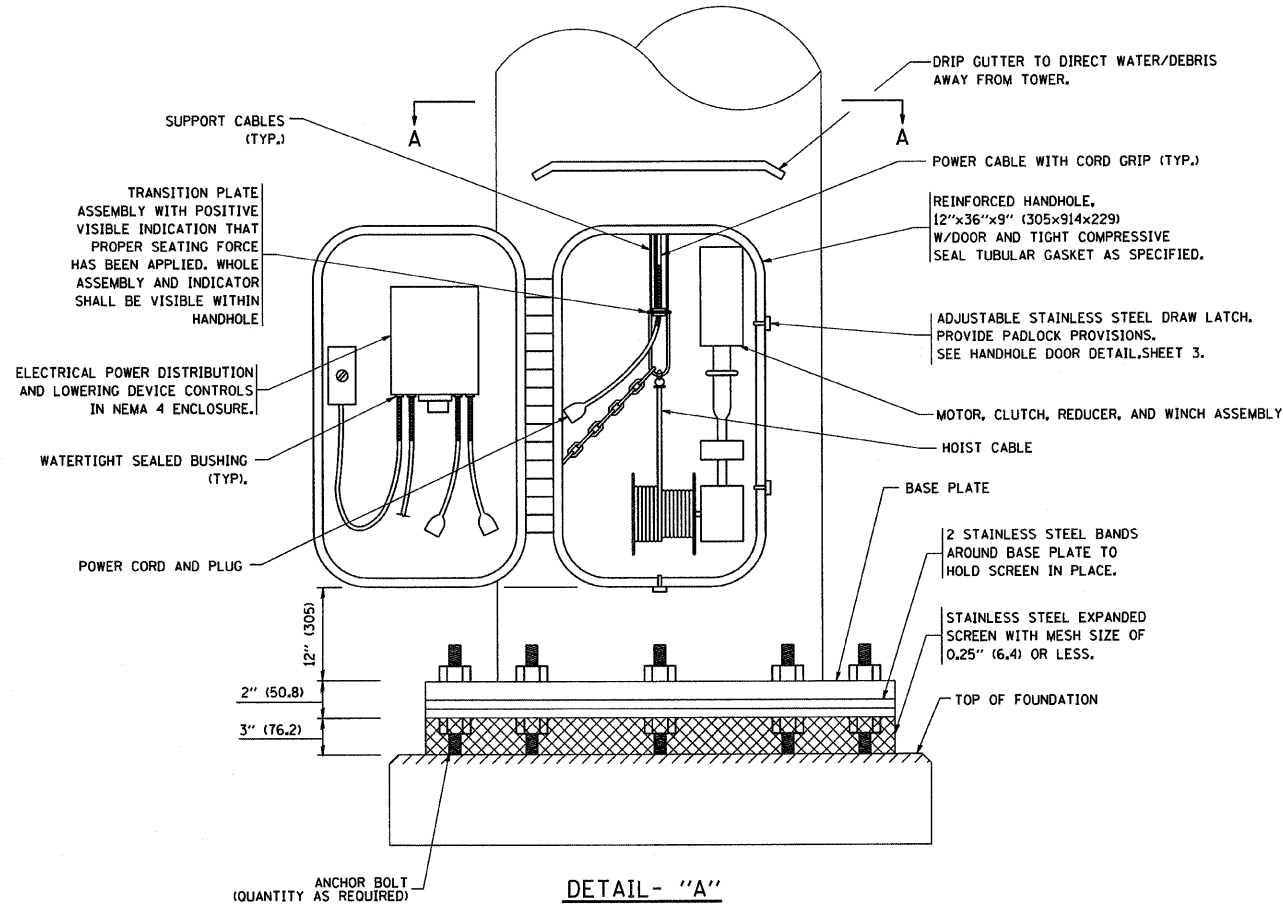
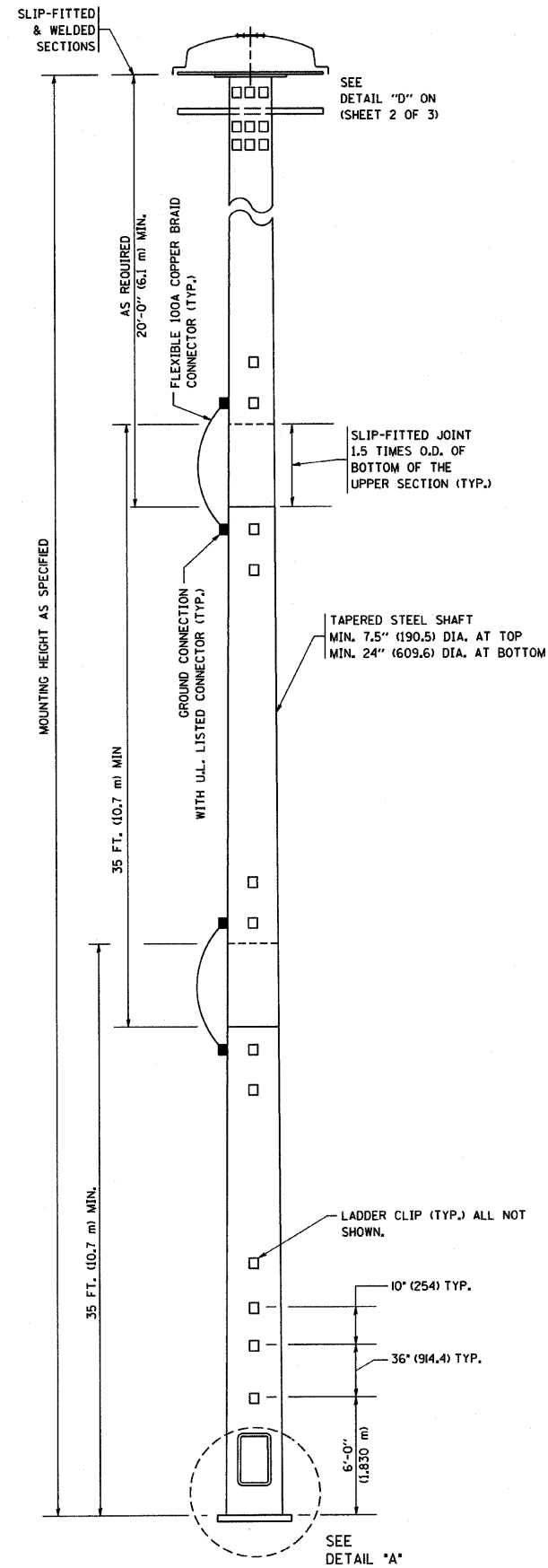

NOTES:

1. ALL DIMENSIONS ARE IN INCHES (MILLIMETERS) UNLESS OTHERWISE SHOWN.
2. THE DESIGN SHALL BE BASED UPON AASHTO "STANDARD SPECIFICATIONS FOR STRUCTURAL SUPPORTS FOR HIGHWAY SIGNS, LUMINAIRES AND TRAFFIC SIGNALS" CURRENT AT THE TIME THE PROJECT IS ADVERTISED AND A TOTAL COMBINED LUMINAIRE WEIGHT OF 720 LBS. (326 kg) AND HAVING A TOTAL PROJECTED AREA OF 24 SQ. FT. (7.3 sq. m).
3. ALL TOWER SHAFT COMPONENTS, INCLUDING, BUT NOT LIMITED TO THE SHAFT SECTIONS, BASE PLATE, LADDER CLIPS, HANDHOLE DOOR, HANDHOLE REINFORCING, RAIN GUTTER, AND BASE PLATE, SHALL BE FABRICATED FROM HIGH-STRENGTH, LOW ALLOY, STEEL WITH A MINIMUM YIELD STRENGTH OF 50,000 PSI (345 K PA) ACCORDING TO AASHTO M 223 (ASTM A 572 GR50)
4. THE ELECTRIC MOTOR, MOTOR GEAR REDUCER, WINCH DRUM ASSEMBLY AND AUTOMATIC SHUTOFF SWITCH OF THE LOWERING DEVICE SHALL BE ACCESSIBLE FROM THE FRONT OF THE TOWER FOR EASY REMOVAL AND MAINTENANCE. ALL COMPONENTS SHALL BE REMOVABLE THROUGH THE HANDHOLE.
5. THE LIGHT TOWER SHAFT SHALL HAVE LADDER CLIPS. CLIPS SHALL BEGIN 6 FT. (1.8 m) ABOVE THE BASE PLATE WITH ALTERNATE 36 INCH (900) AND 10 INCH (250) SPACING THEREAFTER, FOR THE ENTIRE LENGTH. THE TOP 10 FT. (3 m) OF THE POLE SHAFT SHALL HAVE 3 SETS OF CLIPS. EACH SET OF CLIPS SHALL BE 120 DEGREES APART. CLIPS SHALL BE 0.25 X 2 INCHES (6 X 50) WELDED TO THE SHAFT TO PRODUCE A SLOT 0.625 INCHES (15.9) DEEP AND 1.625 INCHES (41.3) LONG. THE TOP INSIDE EDGE SHALL BE CHAMFERED.
6. A COPPER BONDING JUMPER SHALL BOND SLIP-FIT POLE SECTIONS TOGETHER WITH A FLAT COPPER MESH AND STAINLESS STEEL GROUND LUGS.
7. ALL TOWER SHAFT HARDWARE, SUCH AS GROUND LUGS, JUNCTION BOXES, HARDWARE FOR THE HANDHOLE DOOR, INCLUDING THE HANDLE/LATCH MECHANISM, HINGE AND DOOR STOP, SHALL BE STAINLESS STEEL. ALL CONDUIT AND CONDUIT FITTINGS SHALL BE PVC COATED GALVANIZED STEEL.
8. THE ENTIRE TOWER INCLUDING THE SHAFT, HANDHOLE, HANDHOLE DOOR, BASE PLATE AND ALL OTHER ELEMENTS WELDED TO THE SHAFT SHALL BE GALVANIZED IN ACCORDANCE WITH AASHTO M 111 (ASTM A 123) AND THEN PAINTED AS SPECIFIED. THE LUMINAIRE RING SHALL BE PRIMED AND PAINTED AS SPECIFIED.
9. THE FINISH COAT SHALL BE FEDERAL STANDARD COLOR NUMBER 16307 (HANFORD GREY). COLOR SAMPLE TO BE SUBMITTED FOR APPROVAL
10. ALL MULTI-CONDUCTOR CABLES SHALL BE FITTED WITH A HEAT-SHRINK MULTI-LEG BOOT. THE BOOT SHALL MEET MILITARY SPECIFICATION MIL-I-81765/1.
11. PRIOR TO DELIVERY, THE TOWER AND ALL ITS COMPONENTS SHALL BE INSPECTED BY THE MANUFACTURER'S REPRESENTATIVE IN THE PRESENCE OF THE ENGINEER. ANY PARTS FOUND TO BE DEFECTIVE SHALL BE REPAIRED OR REPLACED.
12. THE LIGHT TOWER SHALL BE STRAIGHT AND CENTERED ON ITS LONGITUDINAL AXIS, UNDER NO-WIND CONDITIONS, SO WHEN EXAMINED WITH A TRANSIT FROM ANY DIRECTION, THE DEVIATION FROM THE NORMAL SHALL NOT EXCEED 1/8 IN. IN 3 FT (2 mm IN 1 m) WITHIN ANY 5 FT (1.5 m) OF HEIGHT, WITH TOTAL DEVIATION NOT TO EXCEED 3 IN. (75) FROM THE VERTICAL AXIS THROUGH THE CENTER OF THE POLE BASE.
13. PVC CONDUIT WILL NOT BE ALLOWED.
14. THE NUMBER OF COUNTER WEIGHTS TO BE SUPPLIED AS A PART OF THE LIGHT TOWER PAY ITEM IS.

FILE NAME = W:\diststd\22x34\be500.dgn	USER NAME = gaglianobt	DESIGNED -	REVISED - R. TOMSONS 08-04-03	STATE OF ILLINOIS DEPARTMENT OF TRANSPORTATION	HIGH MAST LIGHT TOWER 90 FT TO 120 FT (27 m TO 36 m)			F.A. - RTE.	SECTION	COUNTY	TOTAL SHEETS	SHEET NO.	
	PLOT SCALE = 50.0000 ' / IN.	DRAWN -	REVISED -		SCALE: NONE	SHEET NO. 1 OF 3 SHEETS	STA.	TO STA.	157	2008-082L	COOK/WILL	49	45
	PLOT DATE = 1/4/2008	CHECKED -	REVISED -							BE-500	CONTRACT NO. 60F84		
		DATE -	REVISED -								FED. ROAD DIST. NO. 1 (ILLINOIS) FED. AID PROJECT		

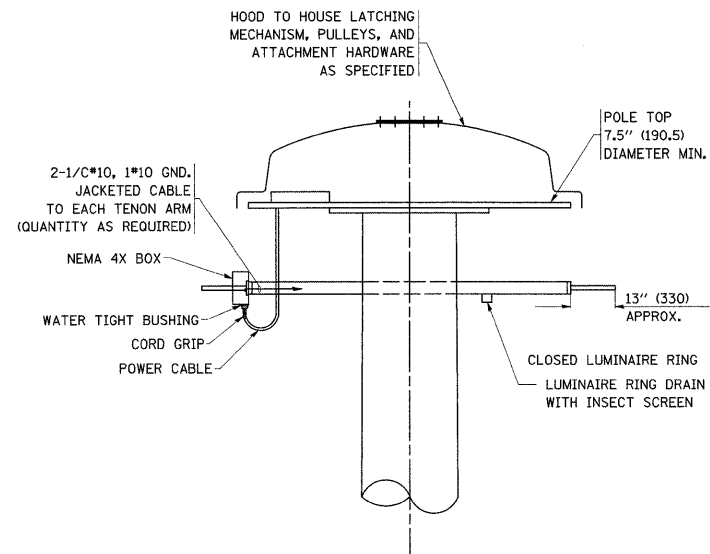

DETAIL--"D"

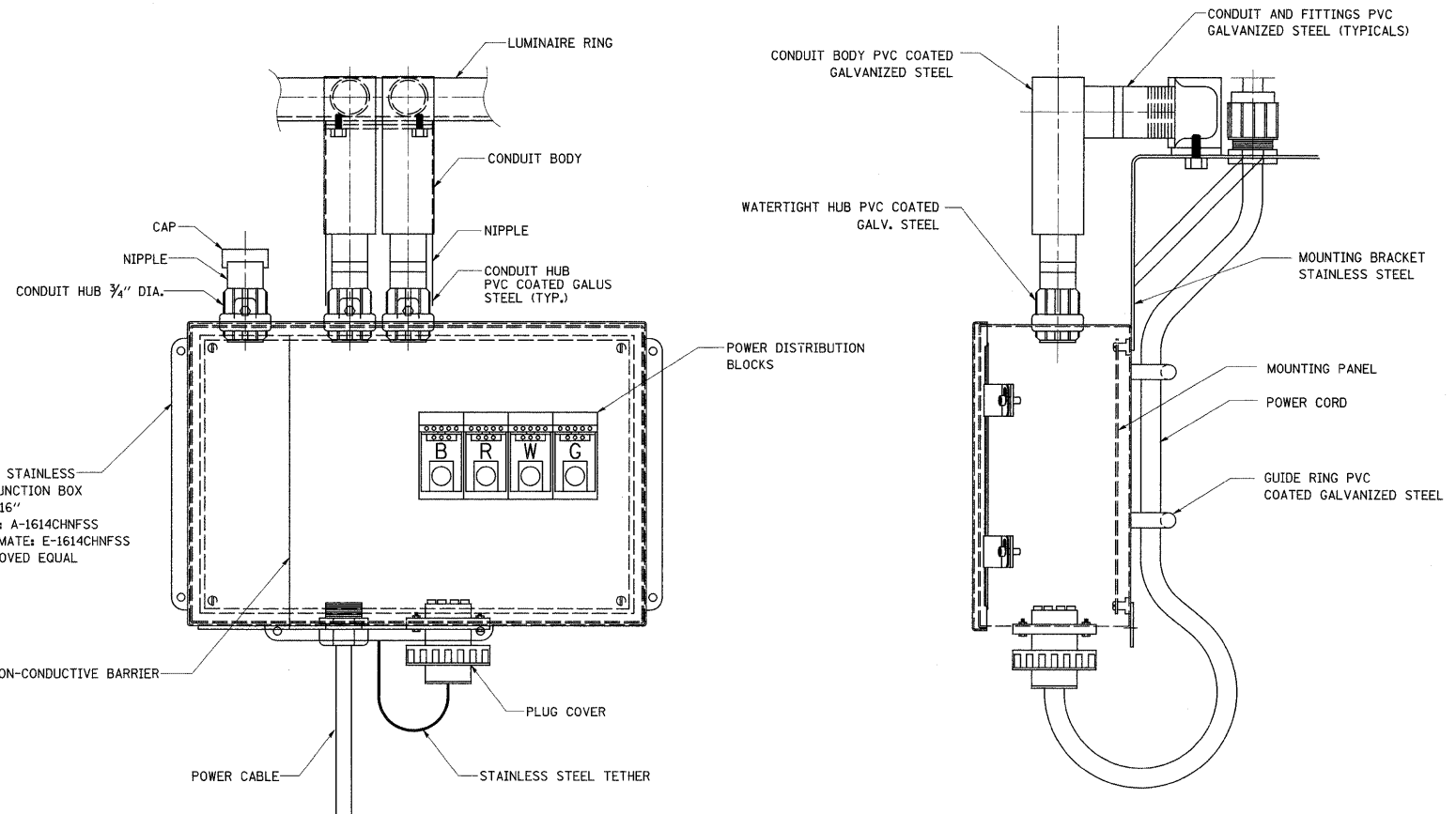

FRONT VIEW

SIDE VIEW

LUMINAIRE RING TERMINAL BOX

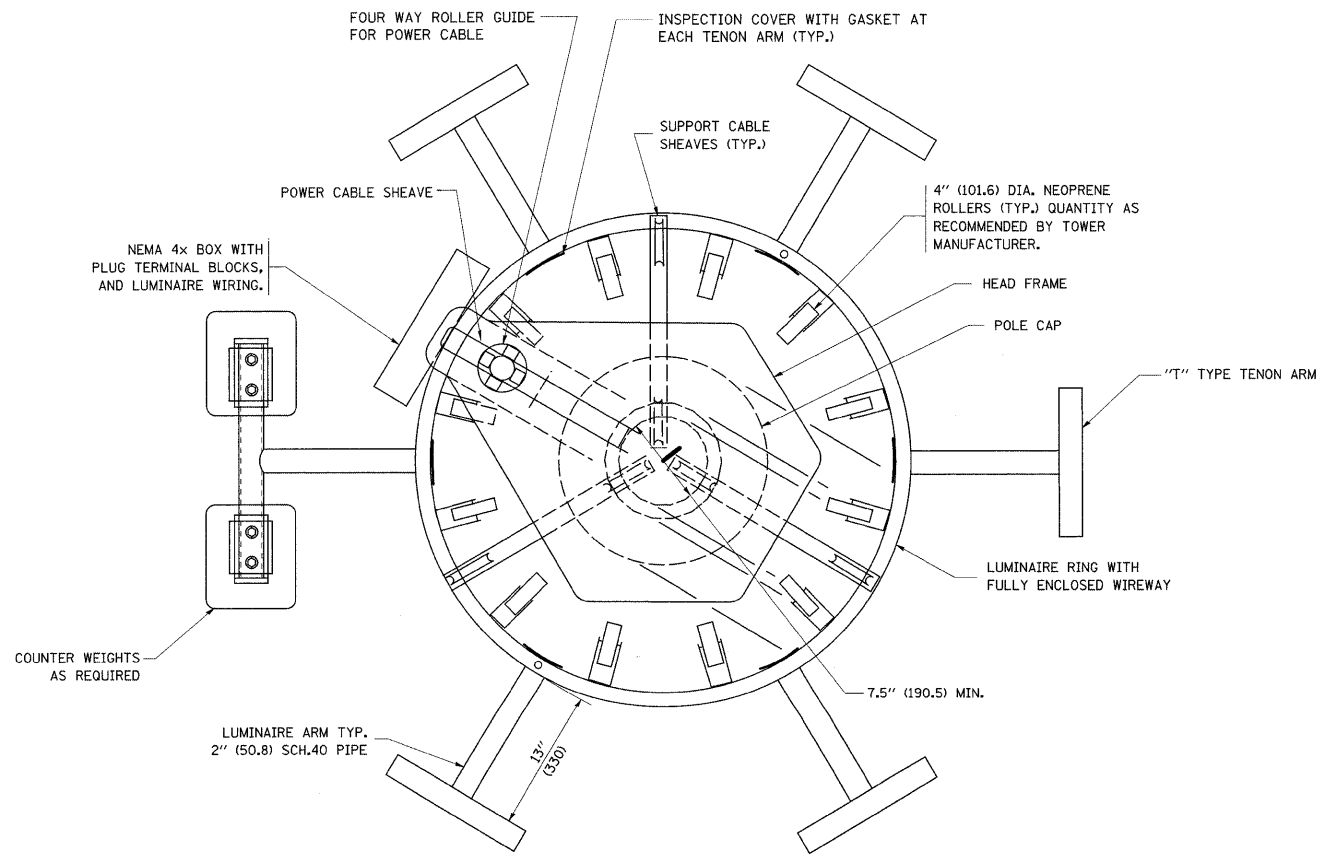

SECTION A-A

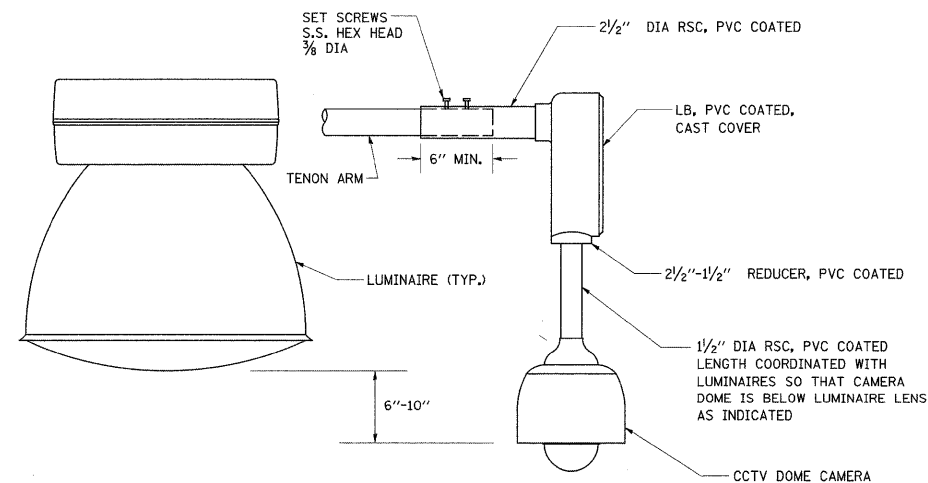

CCTV CAMERA MOUNTING DETAIL

NOTES:

- LUMINAIRE WIRES SHALL EXTEND 24 INCHES (609 mm) LONGER THAN THEIR RESPECTIVE TENON ARM AND SHALL BE TRAINED BACK INTO THE ARM WHICH SHALL THEN BE CLOSED WITH A CAP AS SPECIFIED. ALL WIRES SHALL BE CAPPED WITH HEAT SHRINK INSULATING BOOTS, CRIMP CAPS ARE UNACCEPTABLE. ALL RING WIRES SHALL BE TAGGED WITH WIRE MARKERS AT BOTH ENDS. THE TENON ARMS SHALL ALSO BE TAGGED CORRESPONDING TO THE WIRING CONTAINED WITHIN.
- SPLICING WILL NOT BE ALLOWED WITHIN THE LUMINAIRE RING.
- ALL TOWER SHAFT HARDWARE, SUCH AS GROUND LUGS, JUNCTION BOXES, HARDWARE FOR THE HANDHOLE DOOR, INCLUDING THE HANDLE/LATCH MECHANISM, HINGE AND DOOR STOP, SHALL BE STAINLESS STEEL. ALL CONDUIT AND CONDUIT FITTINGS SHALL BE PVC COATED GALVANIZED STEEL.
- ALL MULTI-CONDUCTOR CABLES SHALL BE FITTED WITH A HEAT-SHRINK MULTI-LEG BOOT. THE BOOT SHALL MEET MILITARY SPECIFICATION MIL-I-81765/1.

FILE NAME = c:\pwwork\pwwid\l\LEYS\ad\106315\be502.dgn	USER NAME = leysa	DESIGNED - DRAWN -	REVISOR - R. TOMSONS 08-04-03	STATE OF ILLINOIS DEPARTMENT OF TRANSPORTATION	HIGH MAST LIGHT TOWER 90 FT TO 120 FT (27 m TO 36 m)			F.A. - RTE. I-57	SECTION 2008-082 L	COUNTY Cook/Will	TOTAL SHEETS 49	SHEET NO. 46
PLOT SCALE = 50.0000' / IN.	CHECKED -	DATE -	REVISIONS -		SCALE: NONE	SHEET NO. 2 OF 3 SHEETS	STA. TO STA.	FED. ROAD DIST. NO. 1 ILLINOIS FED. AID PROJECT				
PLOT DATE = 4/17/2009	DATE -	REVISIONS -	REVISIONS -		BE-500							
CONTRACT NO. 60F84												

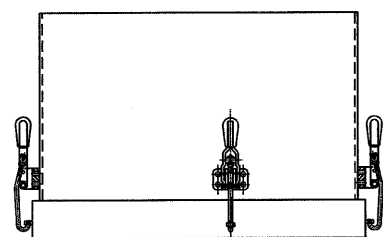

TOP VIEW

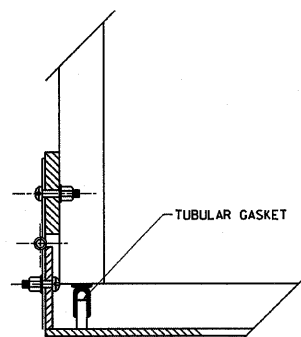

HINGE DETAIL

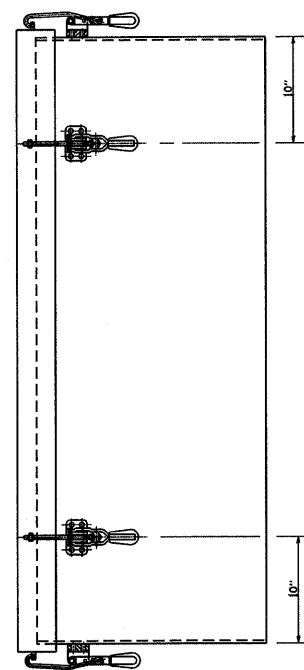

SIDE VIEW

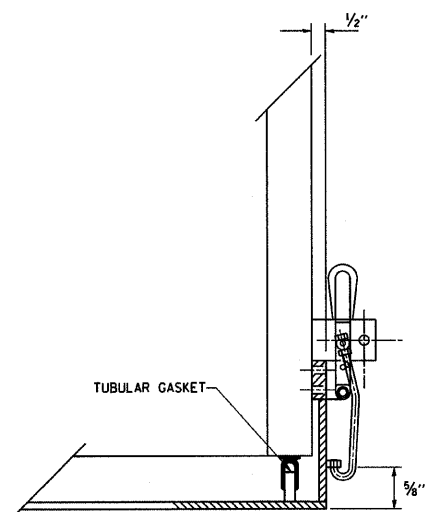

LATCH DETAIL

HANDHOLE DOOR DETAILS

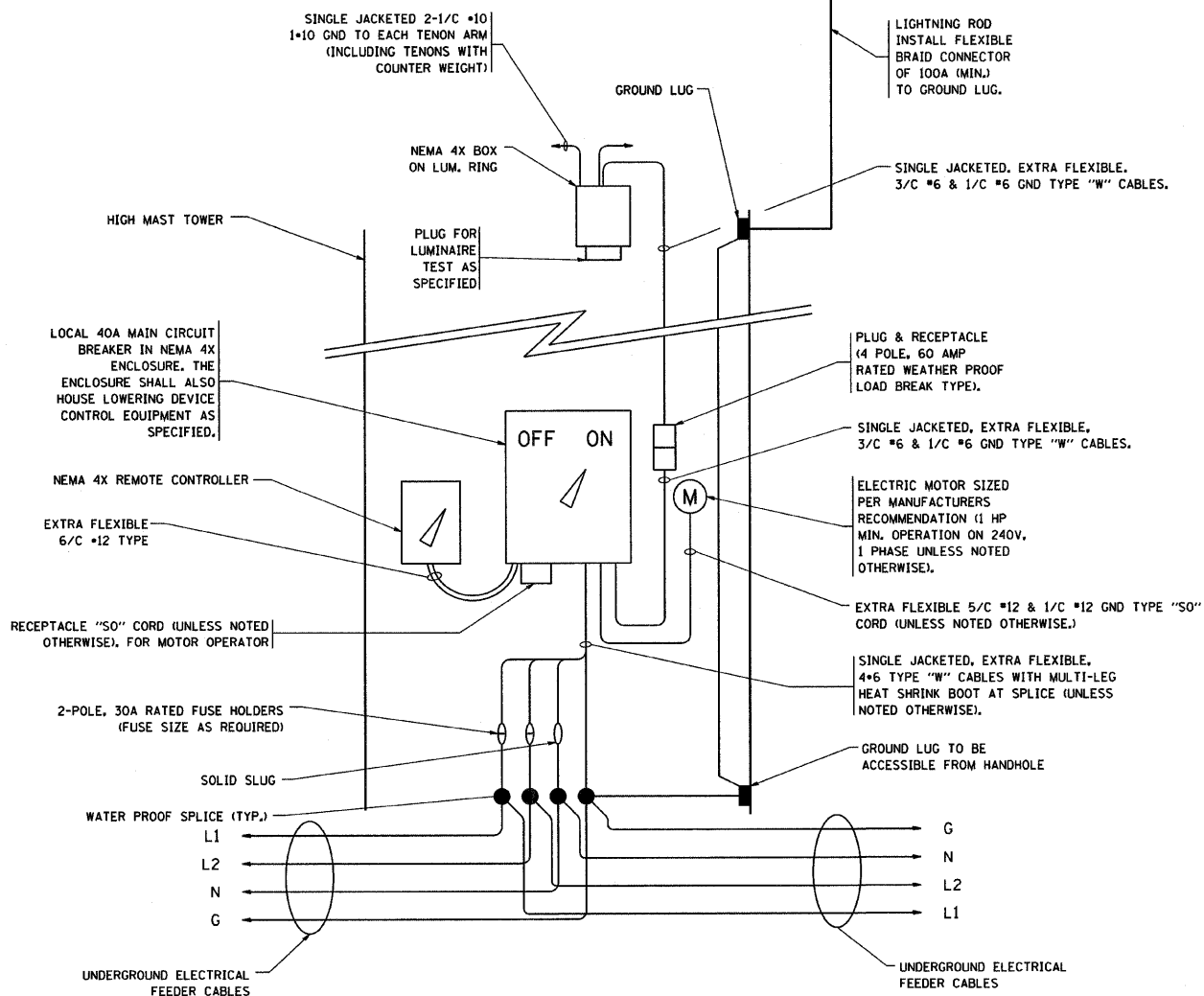

HIGH MAST POLE WIRING DIAGRAM

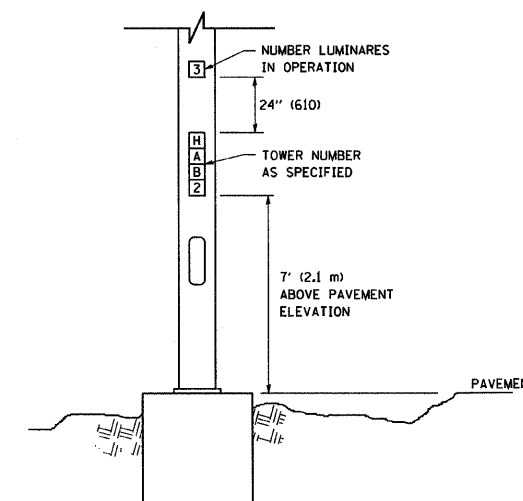

LIGHT TOWER NUMBERING DETAIL

FILE NAME = W:\diststd\22x34\be500.dgn	USER NAME = gaglianobt	DESIGNED -	REVISED - R. TOMSONS 08-04-03
		DRAWN -	REVISED -
	PLOT SCALE = 50.0000' / IN.	CHECKED -	REVISED -
	PLOT DATE = 1/4/2008	DATE -	REVISED -

STATE OF ILLINOIS
DEPARTMENT OF TRANSPORTATION

HIGH MAST LIGHT TOWER 90 FT TO 120 FT (27 m TO 36 m)		F.A. RTE.	SECTION	COUNTY	TOTAL SHEETS	SHEET NO.
SCALE: NONE		157	2008-082L	COOK/WILL	49	47
SHEET NO. 3 OF 3 SHEETS		BE-500		CONTRACT NO. 60F84		
STA. TO STA.		FED. ROAD DIST. NO. 1 (ILLINOIS) FED. AID PROJECT				

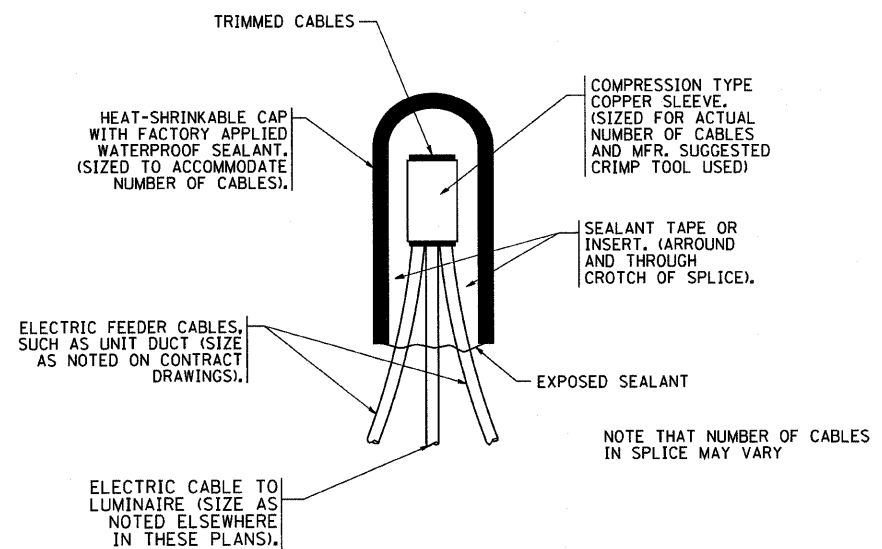

TYPICAL SPLICE DETAIL
N.T.S.

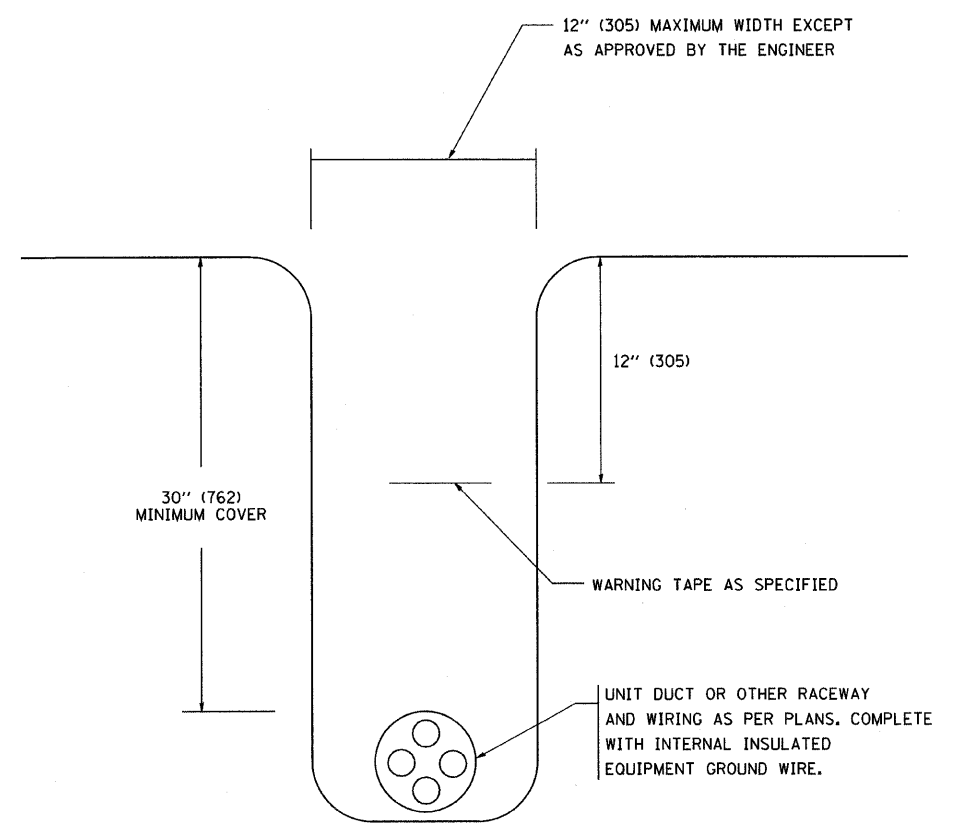

TYPICAL WIRING IN TRENCH DETAIL
N.T.S.

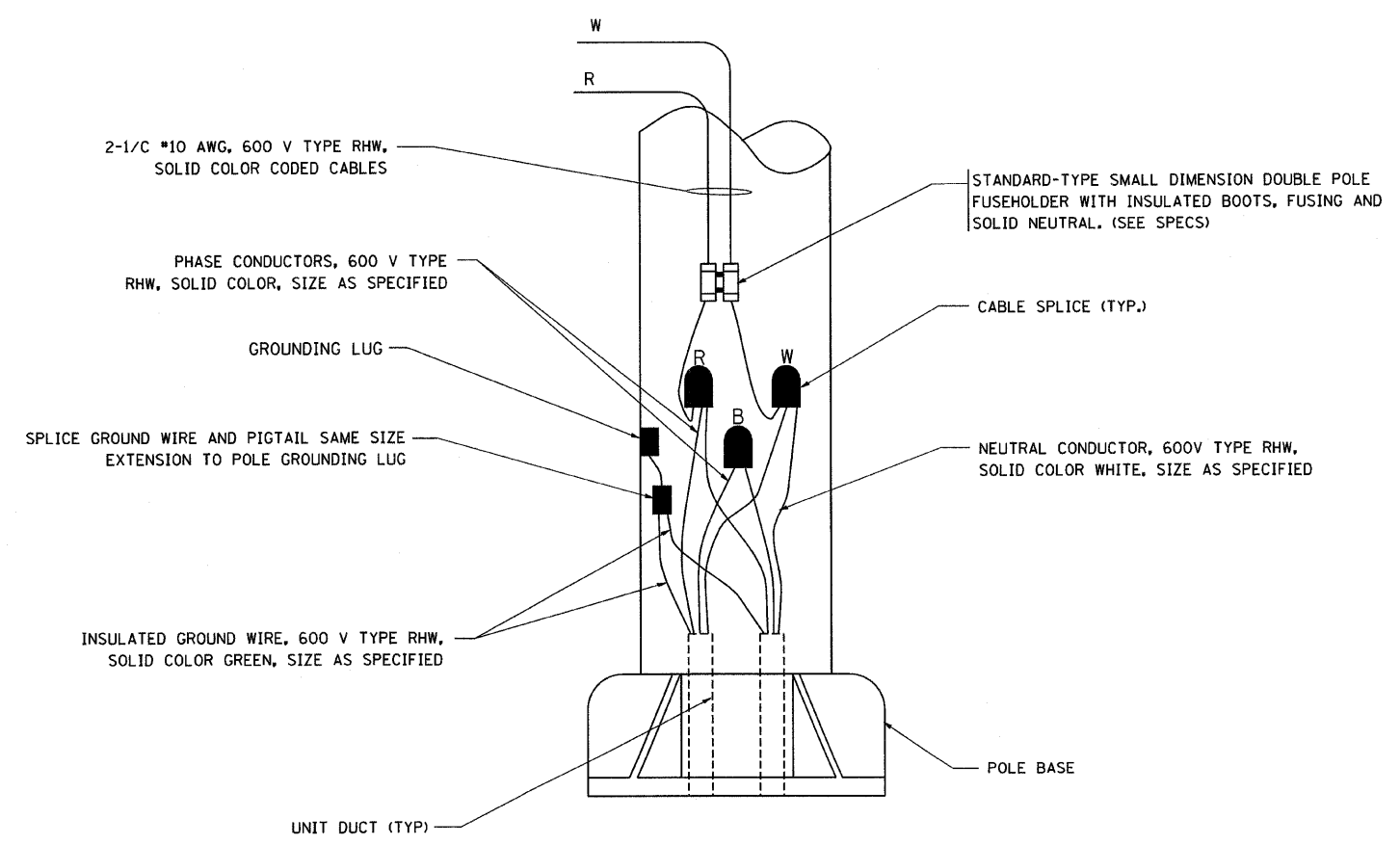

POLE WIRING DETAIL
N.T.S.

FILE NAME = W:\diststd\22x34\ba782.dgn	USER NAME = gaglierobt	DESIGNED -	REVISED - 08-08-03	STATE OF ILLINOIS DEPARTMENT OF TRANSPORTATION	MISC. ELECTRICAL DETAILS SHEET A			F.A. RTE.	SECTION	COUNTY	TOTAL SHEETS	SHEET NO.
	PLOT SCALE = 50,000' / IN.	DRAWN -	REVISED -		IS7	2008-082L	COOK/WILL	49	48			
	PLOT DATE = 1/4/2008	CHECKED -	REVISED -		BE-702		CONTRACT NO. 60824					
		DATE -	REVISED -		SCALE: NONE	SHEET NO. 1 OF 1 SHEETS	STA.	TO STA.	FED. ROAD DIST. NO. 1 (ILLINOIS) FED. AID PROJECT			

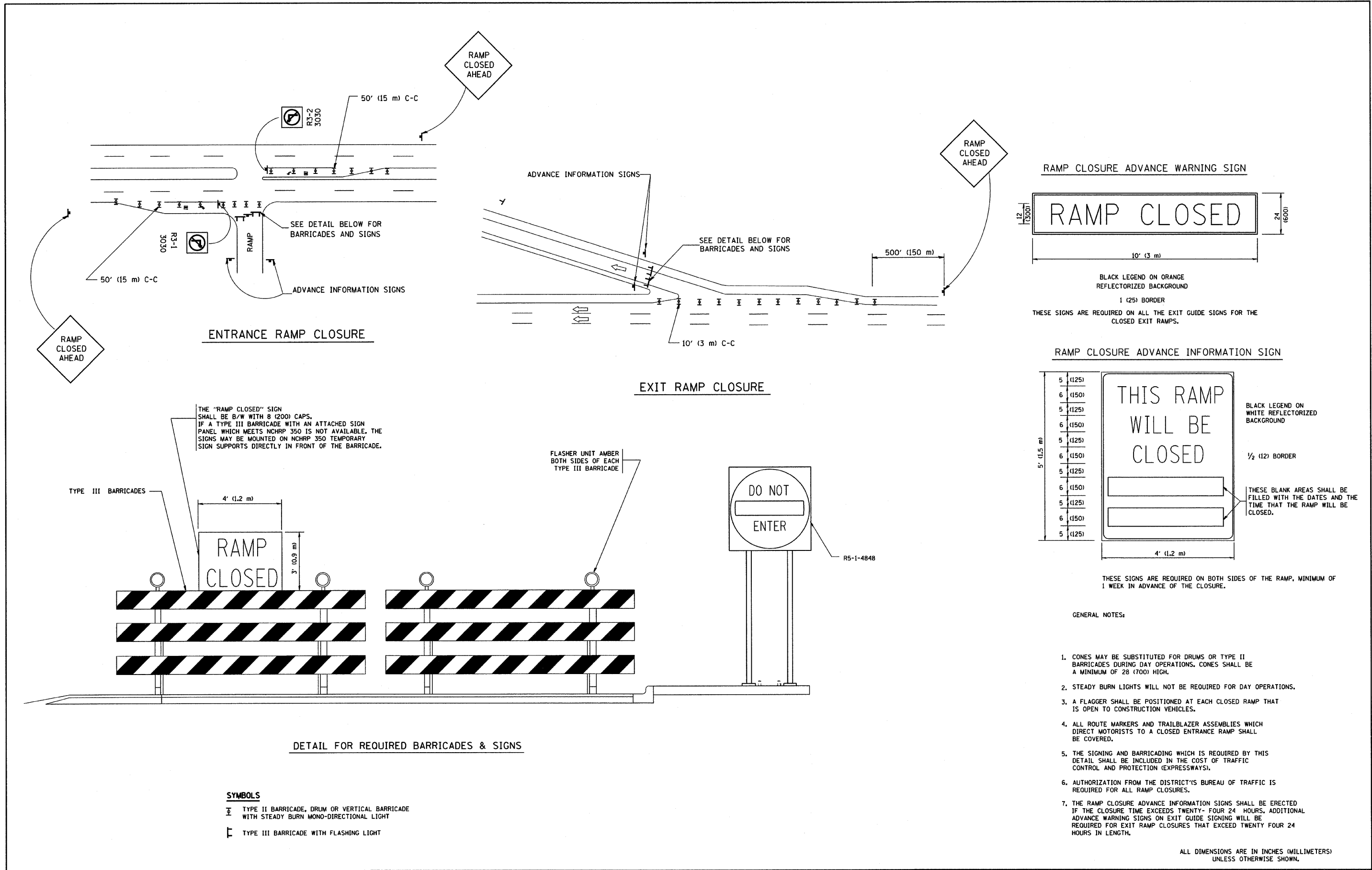

- SYMBOLS**
- ▬ TYPE II BARRICADE, DRUM OR VERTICAL BARRICADE WITH STEADY BURN MONO-DIRECTIONAL LIGHT
 - ⌈ TYPE III BARRICADE WITH FLASHING LIGHT

FILE NAME = W:\diststd\22x34\to08.dgn	USER NAME = gaglianobt	DESIGNED - DWS	REVISED - DWS 12-94	STATE OF ILLINOIS DEPARTMENT OF TRANSPORTATION	FREWAY ENTRANCE AND EXIST RAMP CLOSURE DETAILS			F.A. RTE.	SECTION	COUNTY	TOTAL SHEETS	SHEET NO.	
	PLOT SCALE = 50,000' / IN.	CHECKED -	REVISED - DWS/JAF 12-02					157	2008-082L	Cook/Will	49	49	
	PLOT DATE = 1/4/2008	DATE - 02-83	REVISED - JAF 02-06					TC-08		CONTRACT NO. 60F84			
			REVISED - SPB 01-07					FED. ROAD DIST. NO. 1 (ILLINOIS) FED. AID PROJECT					

PARTIAL RAMP CLOSURE DETAILS

SHOULDER CLOSURE DETAILS

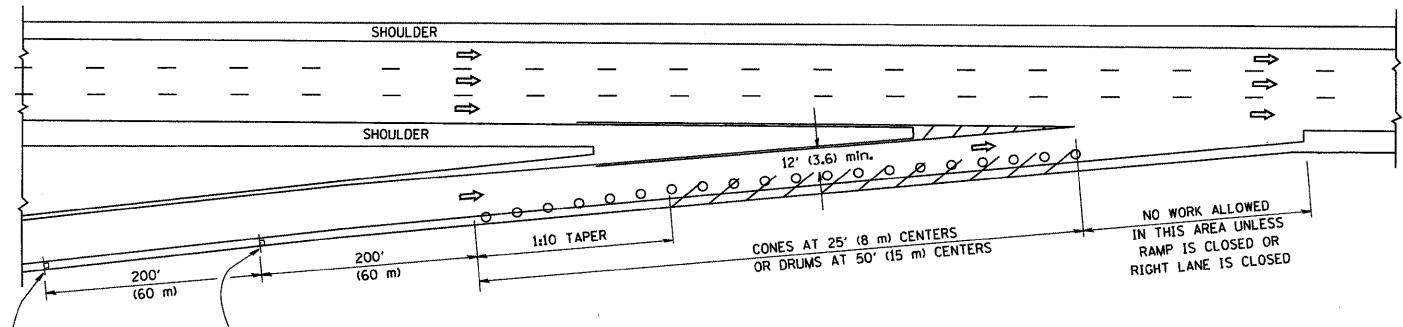

TYPICAL ENTRANCE RAMP

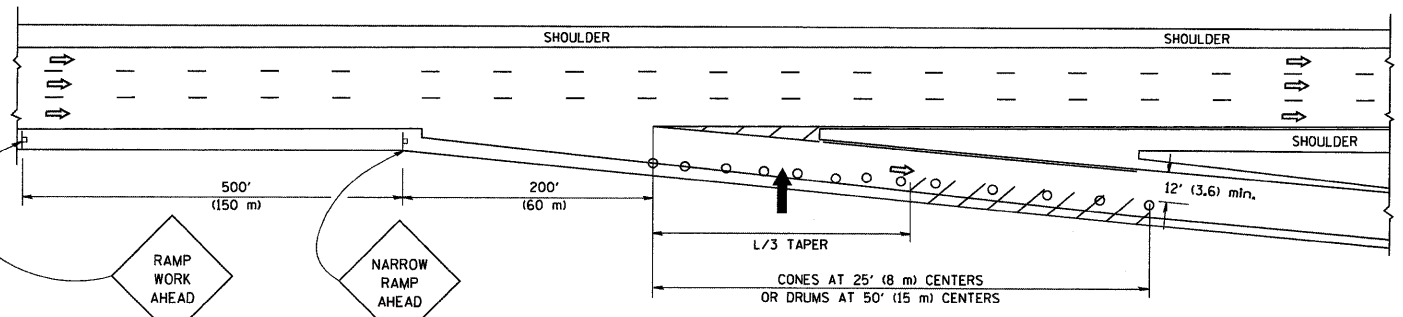

TYPICAL EXIT RAMP

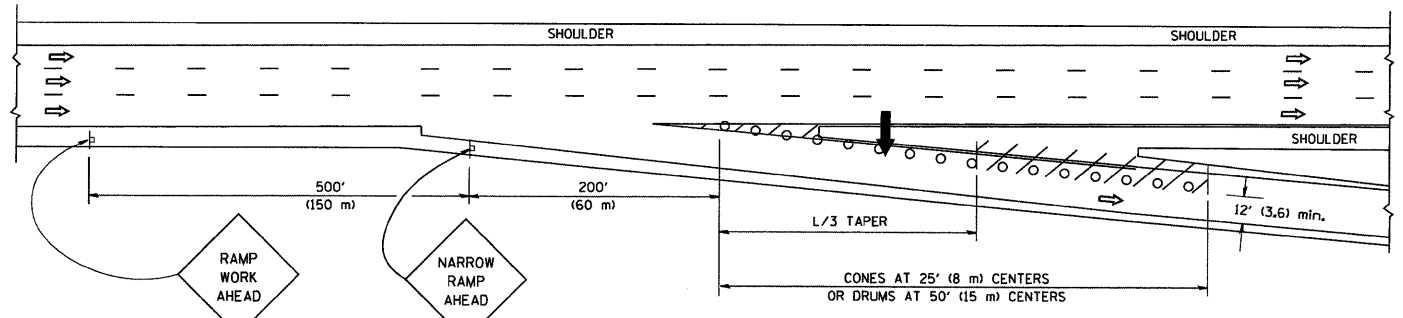

TYPICAL EXIT RAMP

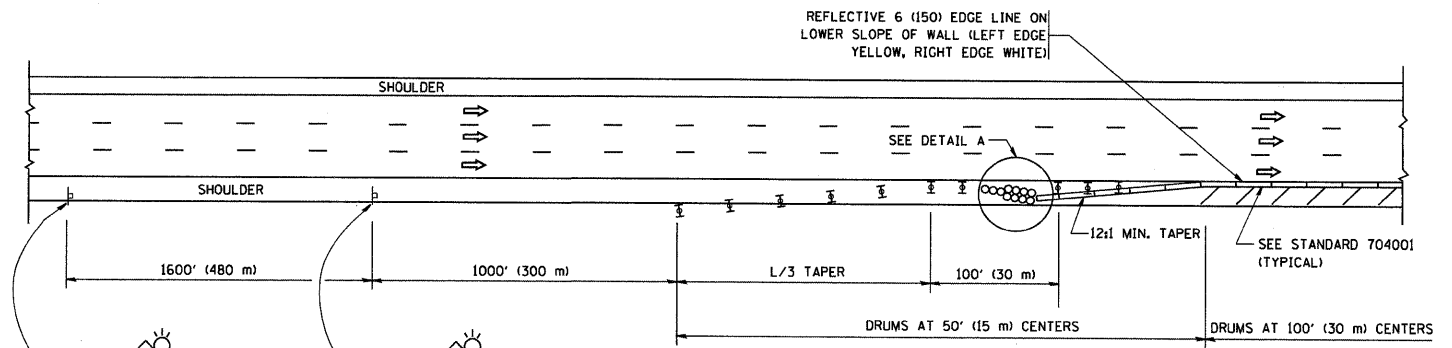

PERMANENT SHOULDER CLOSURE

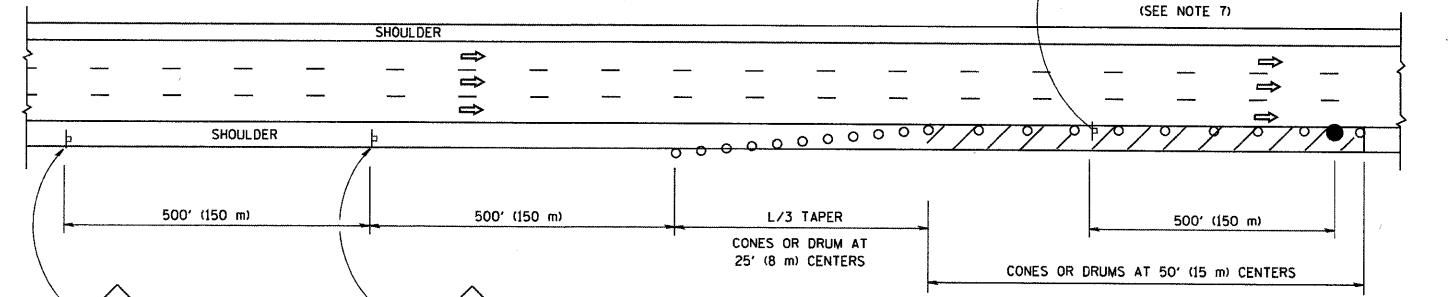

DAYTIME SHOULDER CLOSURE

OR WHEN SPECIFIED INSTALL TEMPORARY CONCRETE BARRIER WALL WITH BARRIER WALL REFLECTORS PER TRAFFIC CONTROL AND PROTECTION (EXPRESSWAYS)

THIS DETAIL IS USED WHERE:
1. VEHICLES, EQUIPMENT, WORKERS OR THEIR ACTIVITIES ENCR OACH IN AN AREA CLOSER THAN 15' (4.5 m) TO THE EDGE OF PAVEMENT FOR A PERIOD IN EXCESS OF 15 MINUTES.

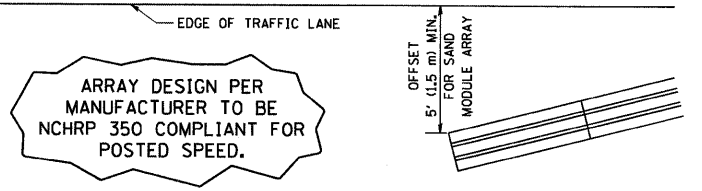

ARRAY DESIGN PER MANUFACTURER TO BE NCHRP 350 COMPLIANT FOR POSTED SPEED.

DETAIL "A"
IMPACT ATTENUATOR, TEMPORARY
(SEE NOTE 5)

ALL DIMENSIONS ARE IN INCHES (MILLIMETERS) UNLESS OTHERWISE SHOWN.

SYMBOLS

- ARROWBOARD
- WORK AREA
- SIGN ON PORTABLE OR PERMANENT SUPPORT
- FLAGGER WITH CONTROL SIGN
- TYPE II BARRICADE, DRUM OR VERTICAL BARRICADE WITH STEADY BURN MONO-DIRECTIONAL LIGHT
- CONE, DRUM OR BARRICADE

GENERAL NOTES

1. THE "L" DISTANCE EQUALS:
SPEED LIMIT FORMULAS
45 mph (80 km/h) METRIC ENGLISH
OR GREATER: L=0.65(WX) L=(WXS)
2. PLASTIC DRUMS WITH HIGH PERFORMANCE REFLECTIVE SHEETING AND STEADY BURNING LIGHTS ARE REQUIRED FOR ALL NIGHTTIME CLOSURES.
3. ALL SIGNS SHALL BE POST MOUNTED IF THE CLOSURE TIME EXCEEDS FOUR DAYS.
4. FLASHING LIGHTS SHALL BE USED DURING THE HOURS OF DARKNESS AND SHALL BE INSTALLED ABOVE THE FIRST TWO SETS OF SIGNS.
5. THE IMPACT ATTENUATOR, TEMPORARY IS NOT REQUIRED WHEN THE TEMPORARY CONCRETE BARRIER WALL IS PROTECTED BY OR IS TIED INTO THE EXISTING GUARDRAIL. IF OFFSET IS LESS THAN 5 FEET USE "TRAFFIC BARRIER TERMINAL, TYPE III, TEMPORARY" DEVICE TO MEET NCHRP350 FOR POSTED SPEED.
6. AUTHORIZATION FROM THE DISTRICT'S BUREAU OF TRAFFIC IS REQUIRED FOR ALL FREEWAY CLOSURES.
7. THE FLAGGER AND FLAGGER SIGN ARE REQUIRED AT THE ABOVE WORK SITES WHEN:
 - a. FOUR OR MORE WORK VEHICLES ENTER THE TRAFFIC LANES IN A ONE HOUR PERIOD.
 - b. THE WORK ACTIVITY REQUIRES FREQUENT ENCR OACHMENT INTO THE LANE OPEN TO TRAFFIC.
 THE FLAGGER SHALL BE STATIONED APPROXIMATELY 100' (30 m) TO 200' (60 m) IN ADVANCE OF THE WORKERS.

FILE NAME = W:\diststd\22x34\td17.dgn

USER NAME = geglienobt
PLOT SCALE = 50.0000' / IN.
PLOT DATE = 1/4/2008

DESIGNED -
DRAWN - D.W.S.
CHECKED -
DATE - 11-96

REVISED - J.A.F. 12-02
REVISED - 04-03
REVISED - J.A.F. 12-06
REVISED - S.P.B. 01-07

STATE OF ILLINOIS
DEPARTMENT OF TRANSPORTATION

TRAFFIC CONTROL DETAILS FOR FREEWAY
SHOULDER CLOSURES AND PARTIAL RAMP CLOSURES

SCALE: NONE SHEET NO. 1 OF 1 SHEETS STA. TO STA.

F.A. RTE.	SECTION	COUNTY	TOTAL SHEETS	SHEET NO.
			49	49A
TC-17		CONTRACT NO.		
FED. ROAD DIST. NO. 1 ILLINOIS FED. AID PROJECT				