

F.A.P. RTE.	SECTION	COUNTY	TOTAL SHEETS	SHEET NO.
	2009-039 TS	WILL	20	1
FED. ROAD DIST. NO.	ILLINOIS	CONTRACT NO. 60G44		

D-91-406-09

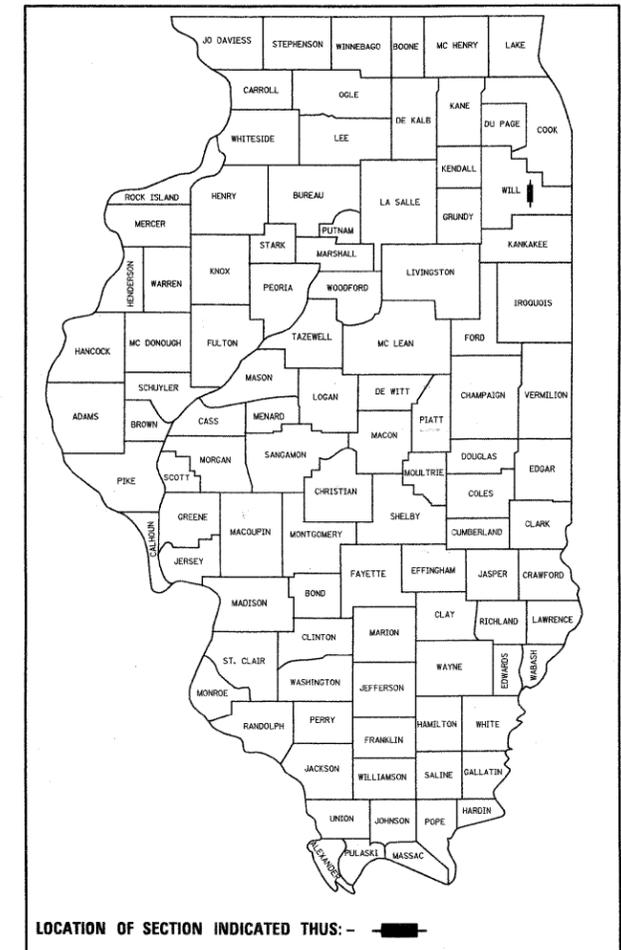

LOCATION OF SECTION INDICATED THUS: - [black rectangle] -

PREPARED BY:  
**CEMCON, Ltd.**  
 Consulting Engineers, Land Surveyors & Planners  
 2280 White Oak Circle, Suite 100  
 Aurora, Illinois 60504-9675  
 Ph: 630.862.2100 Fax: 630.862.2199  
 E-Mail: cadd@cemcon.com Website: www.cemcon.com

STATE OF ILLINOIS  
 DEPARTMENT OF TRANSPORTATION  
 DIVISION OF HIGHWAYS

SUBMITTED March 20 2009  
Kevin M. O'Keefe  
 DEPUTY DIRECTOR OF HIGHWAYS, REGION ENGINEER

May 8, 2009  
Charles J. Ingwersen  
 ENGINEER OF DESIGN AND ENVIRONMENT

May 8, 2009  
Christina M. Reed  
 DIRECTOR OF HIGHWAYS, CHIEF ENGINEER

**PRINTED BY THE AUTHORITY  
 OF THE STATE OF ILLINOIS**

STATE OF ILLINOIS  
 DEPARTMENT OF TRANSPORTATION  
 DIVISION OF HIGHWAYS  
**PLANS FOR PROPOSED  
 FEDERAL AID HIGHWAY**  
 DISTRICT 1  
 HIGHWAY SAFETY IMPROVEMENT PROJECT

*FAU 323*(IL 126 @ Essington Road)  
*FAP 577*(IL 171 @ Woodruff Road)  
*FAP 112* (IL 53 @ Theodore Street  
 IL 53 @ Murphy Road  
 IL 53 @ Belmont Road  
 IL 53 @ Joliet Road)

**PROJECT: HSIP-0005(674)**

**WILL COUNTY  
 SECTION 2009-039 TS  
 C-91-406-09**

**INDEX OF SHEETS**

1. TITLE SHEET
2. GENERAL NOTES
3. SUMMARY OF QUANTITIES
- 4.-7. DISTRICT 1 STANDARD TRAFFIC SIGNAL DESIGN DETAILS
8. PLAN - LED TRAFFIC SIGNAL RETROFIT FLASHER LOCATIONS  
IL. ROUTE 126 AT ESSINGTON ROAD
9. TRAFFIC SIGNAL MODERNIZATION PLAN  
IL. RTE. 171 AT WOODRUFF RD.
10. CABLE PLAN, SCHEDULE OF QUANTITIES AND PHASE DESIGNATION DIAGRAM  
IL. RTE. 171 AT WOODRUFF RD.
11. TRAFFIC SIGNAL MODERNIZATION PLAN  
IL. ROUTE 53 AT IL. ROUTE 7 (THEODORE ST.)
12. CABLE PLAN, SCHEDULE OF QUANTITIES AND PHASE DESIGNATION DIAGRAM  
IL. ROUTE 53 AT IL. ROUTE 7 (THEODORE ST.)
13. TRAFFIC SIGNAL MODIFICATION PLAN  
IL. ROUTE 53 (INDEPENDENCE BLVD.) AT MURPHY DRIVE
14. SCHEDULE OF QUANTITIES, CABLE PLAN AND PHASE DESIGNATION DIAGRAM  
IL. ROUTE 53 (INDEPENDENCE BLVD.) AT MURPHY DRIVE
15. TRAFFIC SIGNAL MODIFICATION PLAN  
IL. ROUTE 53 (INDEPENDENCE BLVD.) AT BELMONT DRIVE
16. SCHEDULE OF QUANTITIES, CABLE PLAN AND PHASE DESIGNATION DIAGRAM  
IL. ROUTE 53 (INDEPENDENCE BLVD.) AT BELMONT DRIVE
17. TRAFFIC SIGNAL MODIFICATION PLAN  
IL. ROUTE 53 AT JOLIET ROAD
18. SCHEDULE OF QUANTITIES, CABLE PLAN AND PHASE DESIGNATION DIAGRAM  
IL. ROUTE 53 AT JOLIET ROAD
19. INTERCONNECT SCHEMATIC  
IL. ROUTE 53 FROM TAYLOR ROAD TO INTERNATIONALE PARKWAY
20. MAST ARM MOUNTED STREET NAME SIGN  
IL. ROUTE 53 AT JOLIET ROAD

**IDOT STANDARDS:**

- 701001-02 OFF-RD OPERATIONS, 2L 2W MORE THAN 15' (4.5m) AWAY
- 701011-02 OFF-RD MOVING OPERATIONS, 2L 2W, DAY ONLY
- 701101-02 OFF-RD OPERATIONS, MULTILANE, 15' (4.5 m) TO 24' (600 mm) FROM PAVEMENT EDGE
- 701106-02 OFF-RD OPERATIONS, MULTILANE, MORE THAN 15' (4.5 m) AWAY
- 701301-03 LANE CLOSURE, 2L, 2W, SHORT TIME OPERATIONS
- 701201-03 LANE CLOSURE, 2L, 2W, DAY ONLY, FOR SPEEDS > 45 MPH
- 701421-02 LANE CLOSURE, MULTILANE, DAY OPERATIONS ONLY, FOR SPEEDS > 45 MPH TO 55 MPH
- 701501-05 URBAN LANE CLOSURE, 2L, 2W, UNDIVIDED
- 701601-06 URBAN LANE CLOSURE, MULTILANE, 1W OR 2W WITH NONTRAVERSABLE MEDIAN
- 701701-06 URBAN LANE CLOSURE, MULTILANE INTERSECTION
- 701901-01 TRAFFIC CONTROL DEVICES
- 720001-01 SIGN PANEL MOUNTING DETAILS
- 814001-02 HANDHOLES
- 814006-02 DOUBLE HANDHOLES
- 857001-01 STANDARD PHASE DESIGNATION DIAGRAMS AND PHASE SEQUENCES
- 886001-01 DETECTOR LOOP INSTALLATIONS
- 862001-01 UNINTERRUPTIBLE POWER SUPPLY (UPS)
- 877001-04 STEEL MAST ARM ASSEMBLY AND POLE 16' THROUGH 55'
- 877011-04 STEEL COMB. MAST ARM ASSEMBLY AND POLE 16' THROUGH 55'
- 878001-07 CONCRETE FOUNDATION DETAILS
- 880001-01 SPAN WIRE MOUNTED SIGNALS AND FLASHING BEACON INSTALLATION
- 880006-01 TRAFFIC SIGNAL MOUNTING DETAILS

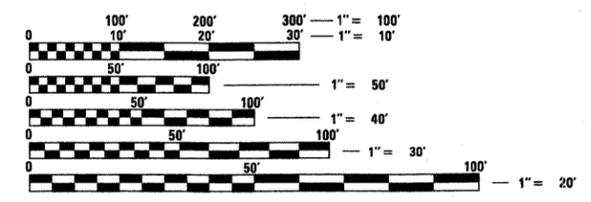

FULL SIZE PLANS HAVE BEEN PREPARED USING STANDARD ENGINEERING SCALES. REDUCED SIZED PLANS WILL NOT CONFORM TO STANDARD SCALES. IN MAKING MEASUREMENTS ON REDUCED PLANS, THE ABOVE SCALES MAY BE USED.

J.U.L.I.E.  
 JOINT UTILITY LOCATING INFORMATION FOR EXCAVATORS  
 1-800-892-0123  
 OR 811

**CONTRACT NO. 60G44**

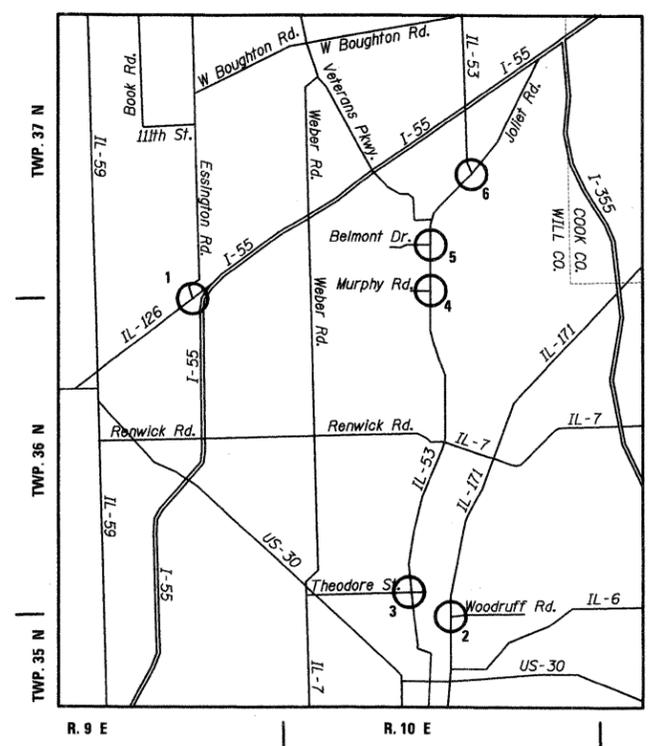

- LEGEND:**
1. IL 126 @ Essington Road
  2. IL 171 @ Woodruff Road
  3. IL 53 @ Theodore Street
  4. IL 53 @ Murphy Road
  5. IL 53 @ Belmont Road
  6. IL 53 @ Joliet Road



**BRUCE P. TALBOT**  
 082-046494  
 REGISTERED  
 PROFESSIONAL  
 ENGINEER  
 OF  
 ILLINOIS

*Bruce P. Talbot*  
 03-18-2009  
 Expires: 11-30-2009

BUREAU OF TRAFFIC, DISTRICT ONE: STEPHEN TRAVIA / DARYLE DREW (847) 705-4420

GENERAL NOTES:

1. ALL CONSTRUCTION SHALL BE DONE IN ACCORDANCE WITH THE "STANDARD SPECIFICATIONS FOR ROAD AND BRIDGE CONSTRUCTION" ADOPTED JANUARY 1, 2007 (HEREINAFTER REFERRED TO AS THE "STANDARD SPECIFICATIONS"); THE LATEST "SUPPLEMENTAL SPECIFICATIONS" AND "RECURRING SPECIAL PROVISIONS"; THE LATEST EDITION OF THE "ILLINOIS MANUAL ON UNIFORM TRAFFIC CONTROL DEVICES FOR STREETS AND HIGHWAYS"; THE DETAILS IN THE PLANS AND THE SPECIAL PROVISIONS INCLUDED IN THE CONTRACT DOCUMENTS.
2. ANY REFERENCE TO THE STANDARDS THROUGHOUT THE PLANS OR SPECIAL PROVISIONS SHALL BE INTERPRETED AS THE LATEST STANDARD OF THE ILLINOIS DEPARTMENT OF TRANSPORTATION.
3. THE CONTRACTOR SHALL NOTIFY J.U.L.I.E. (1-800-892-0123) AT LEAST 10 DAYS PRIOR TO CONSTRUCTION OF THE PROPOSED IMPROVEMENTS. ALL UTILITIES MUST BE NOTIFIED AND STAKED PRIOR TO CONSTRUCTION.
4. THE CONTRACTOR SHALL FAMILIARIZE HIMSELF WITH THE PLANS AND SHALL NOTIFY THE ENGINEER AT ONCE OF ANY DISCREPANCIES.
5. THE CONTRACTOR IS REQUIRED TO ATTEND AN ILLINOIS DEPARTMENT OF TRANSPORTATION (IDOT) PRECONSTRUCTION MEETING AND SHALL INFORM THE IDOT TRAFFIC ENGINEER BEFORE WORK COMMENCES.
6. THE CONTRACTOR SHALL KEEP PUBLIC STREET PAVEMENTS CLEAN OF DIRT AND DEBRIS.
7. THE CONTRACTOR SHALL BE RESPONSIBLE IN PROVIDING SAFE AND HEALTHFUL CONDITIONS THROUGHOUT THE CONSTRUCTION OF THE PROPOSED IMPROVEMENTS.
8. THE CONTRACTOR SHALL BE RESPONSIBLE FOR THE PROTECTION OF ALL UNDERGROUND AND SURFACE UTILITIES EVEN THOUGH THEY MAY NOT BE SHOWN ON THE PLANS. ANY UTILITY THAT IS DAMAGED DURING CONSTRUCTION SHALL BE RESTORED TO A CONDITION EQUAL TO THAT EXISTING BEFORE THE DAMAGE INCURRED. THIS WORK SHALL BE AT THE CONTRACTOR'S EXPENSE.
9. RESTORATION OF THE WORK AREA SHALL BE INCIDENTAL TO THE RELATED PAY ITEMS AND SHALL BE REPLACED IN KIND. ALL DAMAGE TO MOWED LAWNS SHALL BE REPLACED WITH AN APPROVED SOD, AND ALL DAMAGE TO UNMOWED FIELDS SHALL BE SEEDED IN ACCORDANCE WITH THE STANDARD SPECIFICATIONS 252 AND 250, RESPECTIVELY.
10. CONTROLLER CABINETS SHALL BE PLACED SO THAT a) THE DOORS OPEN AWAY FROM THE CURB OR TRAVEL WAY., b) AND THE TRAFFIC MOVEMENTS AT THE INTERSECTION ARE VISIBLE FROM THE CONTROLLER.
11. ANY CONTROLLER CABINET WHETHER NEW OR EXISTING TO RECIEVE UPS, WILL HAVE A "L" SHAPED 4 FEET CONCRETE MAINTENANCE PAD INSTALLED. SEE PLANS FOR DETAIL. THE COST OF INSTALLATION OF CONCRETE PAD IS INCIDENTAL TO NEW CONTROLLER AND OR UPS INSTALLATIONS.

FILE NAME = \\MICROST\352072\ 02-GENNOTES	USER NAME = RDS	DESIGNED - KK	REVISED -
		DRAWN - RDS	REVISED -
	PLOT SCALE = 1"=20'	CHECKED - BPT	REVISED -
	PLOT DATE = 03-18-09	DATE - 03-18-09	REVISED -

**STATE OF ILLINOIS  
DEPARTMENT OF TRANSPORTATION**

**GENERAL NOTES**

SCALE: N.T.S.    SHEET NO.    OF    SHEETS    STA.    TO STA.

 PREPARED BY: <b>CEMCON, Ltd.</b> Consulting Engineers, Land Surveyors & Planners 2200 White Oak Circle, Suite 100 Aurora, Illinois 60504-9875 Ph: 630.862.2100 Fax: 630.862.2199 E-Mail: oadd@cemcon.com Website: www.cemcon.com				
F.A.P. RTE.	SECTION	COUNTY	TOTAL SHEETS	SHEET NO.
	2009-039 TS	WILL	20	2
CONTRACT NO. 60G44				
FED. ROAD DIST. NO.    ILLINOIS FED. AID PROJECT				

PAY CODE	SUMMARY OF TRAFFIC SIGNAL QUANTITIES	UNIT	TOTAL	90% FED. 10% STATE	90% FED. 10% STATE	90% FED. 10% STATE	90% FED. 10% STATE	90% FED. 10% STATE	90% FED. 10% STATE
				URBAN	IL 126 @	IL 171 @	IL 53 @	IL 53 @	IL 53 @
NUMBER	ITEM	QUANTITY	ESSINGTON RD	WOODRUFF RD	THEODORE ST	MURPHY DR	BELMONT DR	JOLIET RD	
67000400	ENGINEER'S FIELD OFFICE, TYPE A	CAL MO	5		1	1	1	1	1
67100100	MOBILIZATION	L SUM	1	0.16	0.17	0.17	0.17	0.17	0.16
70102620	TRAFFIC CONTROL AND PROTECTION, STANDARD 701501	L SUM	1	0.16	0.17	0.17	0.17	0.17	0.16
70102630	TRAFFIC CONTROL AND PROTECTION, STANDARD 701601	L SUM	1	0.16	0.17	0.17	0.17	0.17	0.16
70102635	TRAFFIC CONTROL AND PROTECTION, STANDARD 701701	L SUM	1	0.16	0.17	0.17	0.17	0.17	0.16
* 72000100	SIGN PANEL, TYPE 1	SQ FT	55				19	12	24
* 72400710	RELOCATE SIGN PANEL-TYPE 1	SQ FT	47				12	19	16
* 72800100	TELESCOPING STEEL SIGN SUPPORT	FOOT	30						30
* 78000400	THERMOPLASTIC PAVEMENT MARKING-LINE 6"	FOOT	930		310	620			
* 78000600	THERMOPLASTIC PAVEMENT MARKING-LINE 12"	FOOT	197				82	115	
* 78000650	THERMOPLASTIC PAVEMENT MARKING-LINE 24"	FOOT	344		80	143			121
* 78300400	THERMOPLASTIC PAVEMENT MARKING REMOVAL	SQ FT	371		90	126		34	121
81000700	CONDUIT IN TRENCH, 2 1/2" DIA., GALVANIZED STEEL	FOOT	519				189	222	108
81900200	TRENCH AND BACKFILL FOR ELECTRICAL WORK	FOOT	524				194	222	108
85000200	MAINTENANCE OF EXISTING TRAFFIC SIGNAL INSTALLATION	EACH	6	1	1	1	1	1	1
85700200	FULL-ACTUATED CONTROLLER AND TYPE IV CABINET	EACH	1		1				
85700205	FULL-ACTUATED CONTROLLER AND TYPE IV CABINET, SPECIAL	EACH	1					1	
85700505	FULL-ACTUATED CONTROLLER IN EXISTING CABINET, SPECIAL	EACH	2				1		1
87301225	ELECTRIC CABLE IN CONDUIT, SIGNAL NO. 14 3C	FOOT	2347				1225	931	191
87301245	ELECTRIC CABLE IN CONDUIT, SIGNAL NO. 14 5C	FOOT	7558		279	690	2137	2168	2284
87301255	ELECTRIC CABLE IN CONDUIT, SIGNAL NO. 14 7C	FOOT	1957			65	478	1198	216
87301805	ELECTRIC CABLE IN CONDUIT, SERVICE, NO. 6 2C	FOOT	336		126	128	19	12	51
87301305	ELECTRIC CABLE IN CONDUIT, LEAD-IN, NO. 14 1 PAIR	FOOT	4084				1352	1823	909
87502480	TRAFFIC SIGNAL POST, GALVANIZED STEEL 14 FT.	EACH	7		4		2		1
87502490	TRAFFIC SIGNAL POST, GALVANIZED STEEL 15 FT.	EACH	2			2			
87502500	TRAFFIC SIGNAL POST, GALVANIZED STEEL 16 FT.	EACH	6		2	2		1	1
87502520	TRAFFIC SIGNAL POST, GALVANIZED STEEL 18 FT.	EACH	2				1		1
87700160	STEEL MAST ARM ASSEMBLY AND POLE, 24 FT.	EACH	2					2	
87700210	STEEL MAST ARM ASSEMBLY AND POLE, 34 FT.	EACH	1						1
87700250	STEEL MAST ARM ASSEMBLY AND POLE, 42 FT.	EACH	1						1
87702840	STEEL COMBINATION MAST ARM ASSEMBLY AND POLE 22 FT.	EACH	2				1		1
87702900	STEEL COMBINATION MAST ARM ASSEMBLY AND POLE 34 FT.	EACH	1					1	
87702910	STEEL COMBINATION MAST ARM ASSEMBLY AND POLE 36 FT.	EACH	1				1		
87702920	STEEL COMBINATION MAST ARM ASSEMBLY AND POLE 38 FT.	EACH	1					1	
87800100	CONCRETE FOUNDATION, TYPE A	FOOT	20				12	4	4
87800400	CONCRETE FOUNDATION, TYPE E 30-INCH DIAMETER	FOOT	45				15	30	
87800415	CONCRETE FOUNDATION, TYPE E 36-INCH DIAMETER	FOOT	75				15	30	30
87900200	DRILL EXISTING HANDHOLE <i>(POWERED)</i>	EACH	5					3	2
X8803000	SIGNAL HEAD, LED, 1-FACE, SOLAR POST MOUNTED	EACH	1	1					
88030020	SIGNAL HEAD, LED, 1-FACE, 3-SECTION, MAST-ARM MOUNTED	EACH	22		2	3	4	7	6
88030050	SIGNAL HEAD, LED, 1-FACE, 3-SECTION, BRACKET MOUNTED	EACH	7		2		4	1	
88030080	SIGNAL HEAD, LED, 1-FACE, 4-SECTION, MAST ARM MOUNTED	EACH	4		2	2			
88030100	SIGNAL HEAD, LED, 1-FACE, 5-SECTION, BRACKET MOUNTED	EACH	7		2		1	3	1
88030110	SIGNAL HEAD, LED, 1-FACE, 5-SECTION, MAST-ARM MOUNTED	EACH	9		2	3	1	3	
88030210	SIGNAL HEAD, LED, 2-FACE, 3-SECTION, BRACKET MOUNTED	EACH	3		2				1
88030220	SIGNAL HEAD, LED, 2-FACE, 5-SECTION, BRACKET MOUNTED	EACH	1			1			
88030230	SIGNAL HEAD, LED, 2-FACE, 1-3 SECTION, 1-4 SECTION, BRACKET MOUNTED	EACH	2			2			
88030240	SIGNAL HEAD, LED, 2-FACE, 1-3 SECTION, 1-5 SECTION, BRACKET MOUNTED	EACH	2			1			1
88030310	SIGNAL HEAD, LED, 3-FACE, 3-SECTION, BRACKET MOUNTED	EACH	1						1
88102747	PEDESTRIAN SIGNAL HEAD, L.E.D., 2-FACE, BRACKET MOUNTED WITH COUNTDOWN TIMER	EACH	8		4	4			
88200210	TRAFFIC SIGNAL BACKPLATE, LOUVERED, ALUMINUM	EACH	33		4	8	5	10	6
88800100	PEDESTRIAN PUSH-BUTTON	EACH	8		4	4			
89502300	REMOVE ELECTRIC CABLE FROM CONDUIT	FOOT	15028				5189	6109	3730
89502350	REMOVE AND REINSTALL ELECTRIC CABLE FROM CONDUIT	FOOT	140		140				
89502375	REMOVE EXISTING TRAFFIC SIGNAL EQUIPMENT	EACH	5		1	1	1	1	1
89502385	REMOVE EXISTING CONCRETE FOUNDATION	EACH	14				4.0	5.0	5.0
X0322256	TEMPORARY INFORMATION SIGNING	SQ FT	103		20.6	20.6	20.6	20.6	20.6
X0324183	CLEAN EXISTING ELECTRICAL MANHOLE OR HANDHOLE	EACH	4				4		
X8050015	SERVICE INSTALLATION-POLE MOUNTED	EACH	5		1	1	1	1	1
X8440102	RELOCATE EXISTING LUMINAIRE	EACH	4		2		2	2	
X8730027	ELECTRIC CABLE IN CONDUIT, GROUNDING NO. 6 1C	FOOT	2243		510	128	431	508	666
X8730250	ELECTRIC CABLE IN CONDUIT, NO. 20 3/C, TWISTED, SHIELDED	FOOT	1198				650	357	191
X8620020	UNINTERRUPTIBLE POWER SUPPLY	EACH	5		1	1	1	1	1
X8950200	REBUILD EXISTING HANDHOLE	EACH	4				2	1	1

\*Specialty Items

FILE NAME = \MICROST\352872\ 03-SUMMARY  
USER NAME = RDS  
DESIGNED - KK  
DRAWN - RDS  
CHECKED - BPT  
DATE - 03-18-09

REVISED -  
REVISED -  
REVISED -  
REVISED -

STATE OF ILLINOIS  
DEPARTMENT OF TRANSPORTATION

SUMMARY OF QUANTITIES

SCALE: N.T.S. SHEET NO. OF SHEETS STA. TO STA.

PREPARED BY:  
**CEMCON, Ltd.**  
Consulting Engineers, Land Surveyors & Planners  
2280 White Oak Circle, Suite 100  
Aurora, Illinois 60504-9675  
Ph: 630.862.2100 Fax: 630.862.2199  
E-Mail: ocd@cemcon.com Website: www.cemcon.com

F.A.P. RTE.	SECTION	COUNTY	TOTAL SHEETS	SHEET NO.
	2009-039 TS	WILL	20	3
CONTRACT NO. 60G44				
FED. ROAD DIST. NO. [ILLINOIS] FED. AID PROJECT				

F.A. RTE.	SECTION	COUNTY	TOTAL SHEETS	SHEET NO.
STA.		TO STA.		
FED. ROAD DIST. NO. 1 ILLINOIS FED. AID PROJECT				

### LOOP DETECTOR NOTES

- EACH PAIR OF LOOP WIRES SHALL BE PLACED IN A SEPARATE UNIT DUCT FROM THE EDGE OF PAVEMENT TO THE HANDHOLE. SPACING BETWEEN THE HOLES DRILLED IN THE PAVEMENT SHALL NOT BE LESS THAN 6" (150 mm). UNIT DUCT SHALL BE INCLUDED IN THE COST OF THE LOOP WIRE.
- THE NUMBER OF LOOP TURNS SHALL BE AS RECOMMENDED BY THE AMPLIFIER MANUFACTURER. ALL ADJACENT SIDES OF THE LOOPS SHALL BE INSTALLED IN SUCH A WAY THAT THE CURRENT FLOW IS IN THE SAME DIRECTION TO REINFORCE ITS MAGNETIC FIELDS FOR SMALL VEHICLE DETECTION.
- EACH LOOP LEAD-IN SHALL BE IDENTIFIED AND PERMANENTLY TAGGED IN THE HANDHOLE. EACH LEAD-IN CABLE TAG SHALL INDICATE THE LOCATION OF THE LOOP, LOOP ROTATION (CLOCKWISE/COUNTERCLOCKWISE), LOOP LEAD-IN DIRECTION (IN OR OUT), LOOP CABLE NUMBER AND LOCATION IN CABINET, AND NUMBER OF TURNS IN THE DETECTOR LOOPS IN WATER PROOF INK AS INDICATED ON THE DISTRICT 1 STANDARD TRAFFIC SIGNAL DESIGN DETAIL. THE CONTRACTOR SHALL MARK LOOP LOCATIONS ON RECORD DRAWINGS AND PRESENT TO THE ENGINEER AFTER FINAL INSPECTION. LOOPS SHALL BE MARKED BY LANE AND LOOP NUMBER. SEE DETAIL BELOW.
- ALL LOOP CABLE SHALL BE FASTENED WITH PLASTIC TIE WRAP TO THE HANDHOLE HOOKS.
- IN ASPHALT PAVEMENT, LOOPS SHOULD BE PLACED IN THE BINDER AND DIVESHOLES MARKED AT THE CURB WITH A SAW-CUT. THE SAW-CUT SHALL BE CUT IN ACCORDANCE WITH LOCAL AND E.P.A. DUST CONTROL REQUIREMENTS. DETECTOR LOOP(S) SHALL NOT BE INSTALLED IN WET CONDITIONS AND THE SAW-CUTS MUST BE FREE OF DEBRIS AND RESIDUE SUCH AS DUST AND WATER WHICH IS TO BE ACHIEVED BY THE USE OF COMPRESSED AIR, WIRE BRUSHING AND HEAT DRYING ACCORDING TO SEALANT MANUFACTURER REQUIREMENTS. THE DETECTOR WIRE SHALL BE HELD IN PLACE BY THE USE OF FORM WEDGES. WEDGES SHALL BE SPACED NO MORE THAN 18" (450 mm) APART.
- LOOP SPLICES SHALL BE SOLDERED USING A SOLDERING IRON. BLOW TORCHES OR OTHER DEVICES WHICH OXIDIZE COPPER CABLE SHALL NOT BE ALLOWED FOR SOLDERING OPERATIONS. SEE DETAIL BELOW RIGHT.
- PREFORMED DETECTOR LOOPS SHALL BE USED, AS SHOWN ON THE PLANS, WHERE NEW CONCRETE PAVEMENT IS PROPOSED. THE INSTALLATION OF PREFORMED LOOPS SHALL BE IN ACCORDANCE WITH THE DISTRICT 1 SPECIFICATIONS OR AS DIRECTED BY THE ENGINEER.

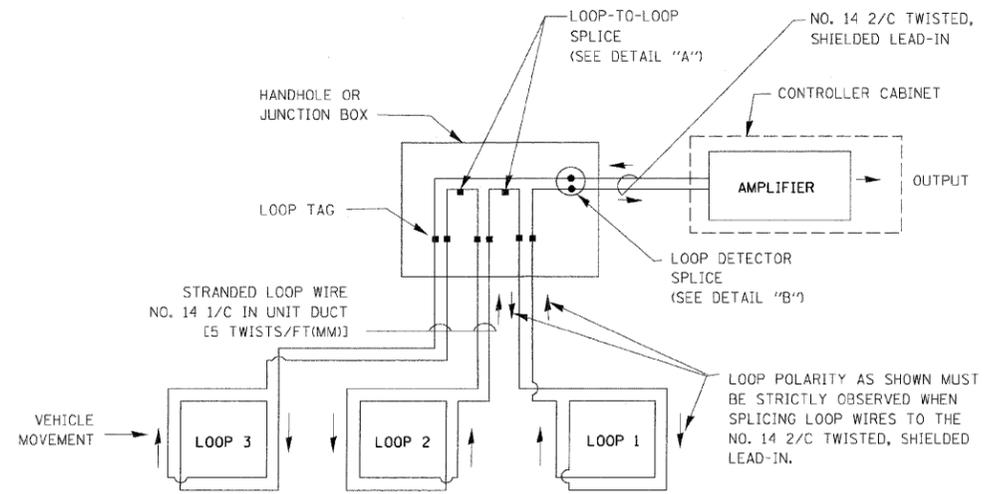

DETECTOR LOOP WIRING SCHEMATIC

- LOOPS SHALL BE SPLICED IN SERIES.
- SAW-CUTS SHALL BE A MINIMUM WIDTH OF 5/16" (8 mm).
- SAW-CUT DEPTHS SHALL BE 3" (75 mm). IF IN CONCRETE, THE SAW-CUT DEPTH SHALL BE TO THE TOP OF THE REINFORCEMENT.
- LOOP CORNERS SHALL BE DRILLED WITH A 2" (50 mm) DIAMETER CORE.

LOOP LEAD-IN CABLE TAG

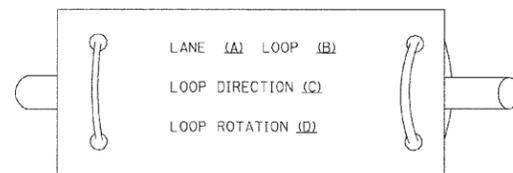

- LANE 1 IS THE LANE CLOSEST TO THE CENTERLINE OF THE ROADWAY
- LOOP #1 IS THE LOOP IN THE LANE CLOSEST TO THE INTERSECTION.
- LABEL LOOP CABLE "IN" OR LOOP CABLE "OUT".
- LABEL LOOP CABLE CLOCKWISE OR LOOP CABLE COUNTERCLOCKWISE.

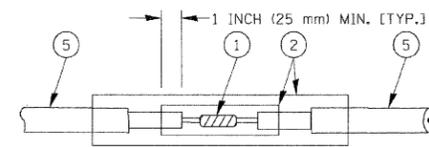

DETAIL "A"  
LOOP-TO-LOOP SPLICE

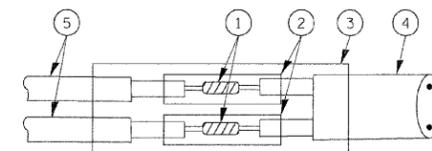

DETAIL "B"  
LOOP-TO-CONTROLLER SPLICE

LOOP DETECTOR SPLICE

- WESTERN UNION SPLICE SOLDERED WITH ROSIN CORE FLUX. ALL EXPOSED SURFACES OF THE SOLDER SHALL BE SMOOTH.
- WCSMW 30/100 HEAT SHRINK TUBE, MINIMUM LENGTH 3" (75 mm), UNDERWATER GRADE.
- WCS 200/750 HEAT SHRINK TUBE, MINIMUM LENGTH 6" (150 mm), UNDERWATER GRADE.
- NO. 14 2/C TWISTED, SHIELDED CABLE.
- LOOP CONDUCTOR WITH FLEXIBLE PLASTIC TUBE.

REVISIONS	
NAME	DATE
CADD	5/30/00
ADD NOTE NO. 8	11/12/01
BUREAU OF TRAFFIC	1-01-02

PREPARED BY:  
**CEMCON, Ltd.**  
 Consulting Engineers, Land Surveyors & Planners  
 2280 White Oak Circle, Suite 100  
 Aurora, Illinois 60504-9675  
 Ph: 630.862.2100 Fax: 630.862.2199  
 E-Mail: cadd@cemcon.com Website: www.cemcon.com

ILLINOIS DEPARTMENT OF TRANSPORTATION  
**DISTRICT ONE  
 STANDARD TRAFFIC SIGNAL  
 DESIGN DETAILS**

SCALE: VERT. NONE  
 HORIZ.  
 DATE 10/18/2002

DRAWN BY: RWP  
 DESIGNED BY: DAD  
 CHECKED BY: DAZ  
 SHEET 1 OF 4

10/18/2002  
 c:\proj\jeffs\d1stdt\Vs05.dgn  
 VPT:SDS

FILE NAME = MICROST\352072\ 04-TS05A	USER NAME = RDS	DESIGNED - KK	REVISED -
		DRAWN - RDS	REVISED -
	PLOT SCALE = 1"=20'	CHECKED - BPT	REVISED -
	PLOT DATE = 03-18-09	DATE - 03-18-09	REVISED -

**STATE OF ILLINOIS  
 DEPARTMENT OF TRANSPORTATION**

**DISTRICT 1 STANDARD TRAFFIC SIGNAL DESIGN DETAILS**

SCALE: N.T.S.	SHEET NO.	OF	SHEETS	STA.	TO STA.
F.A.P. RTE.	SECTION	COUNTY	TOTAL SHEETS	SHEET NO.	
	2009-039 TS	WILL	20	4	
CONTRACT NO. 60G44					
FED. ROAD DIST. NO. ILLINOIS FED. AID PROJECT					

REVISION DATE: 01/01/02

F.A. RTE.	SECTION	COUNTY	TOTAL SHEETS	SHEET NO.
STA.	TO STA.			
FED. ROAD DIST. NO. 1 ILLINOIS FED. AID PROJECT				

**TRAFFIC SIGNAL MAST ARM AND POST**

MAST ARM MOUNTED SIGNAL IN PROPOSED & FUTURE SIDEWALK AREA. INTERSECTION SHOWN WITH PEDESTRIAN SIGNAL AND PUSHBUTTON DETECTOR

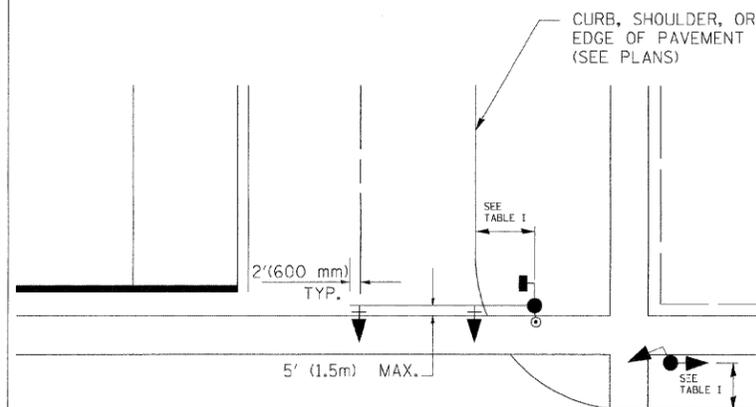

**PEDESTRIAN SIGNAL PUSHBUTTON**

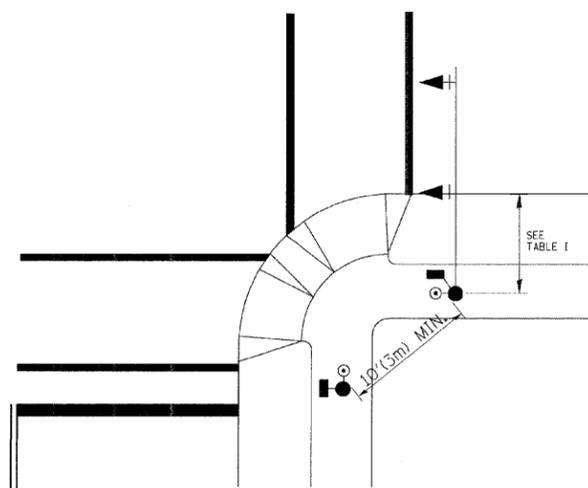

RECOMMENDED PUSHBUTTON LOCATIONS FOR ACCESSIBLE PEDESTRIAN SIGNALS SHALL BE IN ACCORDANCE WITH THE CURRENT MUTCD (SEE NOTE 1). TO MEET MUTCD REQUIREMENTS, PEDESTRIAN SIGNAL PUSHBUTTONS MAY HAVE TO BE MOUNTED ON A SEPARATE POST.

**NOTES:**

- AT ACCESSIBLE PEDESTRIAN SIGNAL LOCATIONS WITH PEDESTRIAN ACTUATION, EACH PUSHBUTTON SHALL ACTIVATE BOTH THE WALK INTERVAL AND THE ACCESSIBLE PEDESTRIAN SIGNALS.  
 AT ACCESSIBLE PEDESTRIAN SIGNAL LOCATIONS, PUSHBUTTONS SHOULD CLEARLY INDICATE WHICH CROSSWALK SIGNAL IS ACTUATED BY EACH PUSHBUTTON. PUSHBUTTONS AND TACTILE ARROWS SHOULD HAVE HIGH VISUAL CONTRAST (SEE THE DEPARTMENT OF JUSTICE'S AMERICANS WITH DISABILITIES ACT STANDARDS FOR ACCESSIBLE DESIGN, 1991). TACTILE ARROWS SHOULD POINT IN THE SAME DIRECTION AS THE ASSOCIATED CROSSWALK. AT CORNERS OF SIGNALIZED LOCATIONS WITH ACCESSIBLE PEDESTRIAN SIGNALS WHERE PEDESTRIAN PUSHBUTTONS ARE PROVIDED, THE PUSHBUTTONS SHOULD BE SEPARATED BY THE DISTANCE OF AT LEAST 10 FT (3m). THIS ENABLES PEDESTRIANS WHO HAVE VISUAL DISABILITIES TO DISTINGUISH AND LOCATE THE APPROPRIATE PUSHBUTTON.  
 PUSHBUTTONS FOR ACCESSIBLE PEDESTRIAN SIGNALS SHOULD BE LOCATED AS FOLLOWS:  
 A: ADJACENT TO A LEVEL ALL-WEATHER SURFACE TO PROVIDE ACCESS FROM A WHEELCHAIR, AND WHERE THERE IS AN ALL WEATHER SURFACE, WHEELCHAIR ACCESSIBLE ROUTE TO THE RAMP.  
 B: WITHIN 5 FT (1.5m) OF THE CROSSWALK EXTENDED.  
 C: WITHIN 10 FT (3m) OF THE EDGE OF CURB, SHOULDER, OR PAVEMENT.  
 D: PARALLEL TO THE CROSSWALK TO BE USED (SEE MUTCD FIGURE 4E-2).  
 E: NORMAL PEDESTRIAN PUSHBUTTON MOUNTING HEIGHT SHOULD BE 3.5 FT (1.05m) ABOVE ADJACENT SIDEWALK.
- PEDESTRIAN SIGNAL FACES SHALL BE MOUNTED WITH THE BOTTOM OF THE HOUSING NOT LESS THAN 8 FT (2.4m) NOR MORE THAN 10 FT (3.0m) ABOVE THE SIDEWALK LEVEL AND SO THERE IS A PEDESTRIAN INDICATION IN THE LINE OF PEDESTRIANS' VISION WHICH PERTAINS TO THE CROSSWALK BEING USED.
- THE BOTTOM OF THE HOUSING OF A VEHICLE SIGNAL FACE, NOT MOUNTED OVER A ROADWAY, SHALL BE AT LEAST 10 FT (3.0m) BUT NOT MORE THAN 15 FT (4.5m) ABOVE THE SIDEWALK OR, ABOVE THE PAVEMENT GRADE AT THE CENTER OF THE HIGHWAY IF NO SIDEWALKS EXIST.
- THE BOTTOM OF THE HOUSING OF A VEHICLE SIGNAL FACE, MOUNTED OVER A ROADWAY, SHALL BE ACCORDING TO CURRENT STATE STANDARDS 877001 AND 877006. (16 FT (5m) MIN., 18 FT (5.5m) MAX., FROM HIGHEST POINT OF PAVEMENT)

**PEDESTRIAN SIGNAL POST**

PEDESTRIAN SIGNAL HEAD AND PEDESTRIAN PUSHBUTTON DETECTOR LOCATION

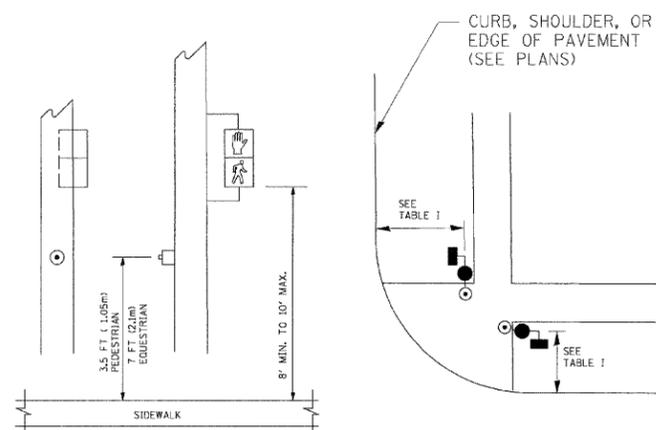

TABLE I

TRAFFIC SIGNAL EQUIPMENT	COMBINATION CONCRETE CURB AND GUTTER (MIN. DIST. FROM BACK OF CURB)	SHOULDER/NON-CURBED AREA (MIN. DIST. FROM EDGE OF PAVEMENT)
TRAFFIC SIGNAL MAST ARM POLE	6 FT (1.8m)	SHOULDER WIDTH + 2FT(0.6m), MINIMUM 10FT(3.0m)
TRAFFIC SIGNAL POST	4 FT (1.2m)	SHOULDER WIDTH + 2FT(0.6m), MINIMUM 10FT(3.0m)
PEDESTRIAN SIGNAL POST	4 FT (1.2m)	SHOULDER WIDTH + 2FT(0.6m), MINIMUM 10FT(3.0m)
PEDESTRIAN PUSHBUTTON	SEE NOTE 1	SEE NOTE 1

REVISIONS	
NAME	DATE
BUREAU OF TRAFFIC	1/01/02

ILLINOIS DEPARTMENT OF TRANSPORTATION  
**DISTRICT 1**  
**STANDARD TRAFFIC SIGNAL**  
**DESIGN DETAILS**

PREPARED BY:  
**CEMCON, Ltd.**  
*Consulting Engineers, Land Surveyors & Planners*  
 2280 White Oak Circle, Suite 100  
 Aurora, Illinois 60504-9675  
 Ph: 630.862.2100 Fax: 630.862.2199  
 E-Mail: codd@cemcon.com Website: www.cemcon.com

SCALE: VERT. NONE  
 HORIZ. NONE  
 DATE 10/18/2002  
 DRAWN BY: RNP  
 DESIGNED BY: DAD  
 CHECKED BY: DAZ  
 SHEET 2 OF 4

TS05

REVISION DATE: 01/01/02

FILE NAME = MICROSTV352072\ 05-TS05B	USER NAME = RDS	DESIGNED - KK	REVISED -
		DRAWN - RDS	REVISED -
		CHECKED - BPT	REVISED -
		DATE - 03-18-09	REVISED -

**STATE OF ILLINOIS**  
**DEPARTMENT OF TRANSPORTATION**

**DISTRICT 1 STANDARD TRAFFIC SIGNAL DESIGN DETAILS**  
 SCALE: N.T.S. SHEET NO. OF SHEETS STA. TO STA.

F.A.P. RTE.	SECTION	COUNTY	TOTAL SHEETS	SHEET NO.
	2009-039 TS	WILL	20	5
CONTRACT NO. 60G44				
FED. ROAD DIST. NO. [ILLINOIS] FED. AID PROJECT				

F.A. RTE.	SECTION	COUNTY	TOTAL SHEETS	SHEET NO.
STA.	TO STA.			
FED. ROAD DIST. NO.	ILLINOIS	FED. AID PROJECT		

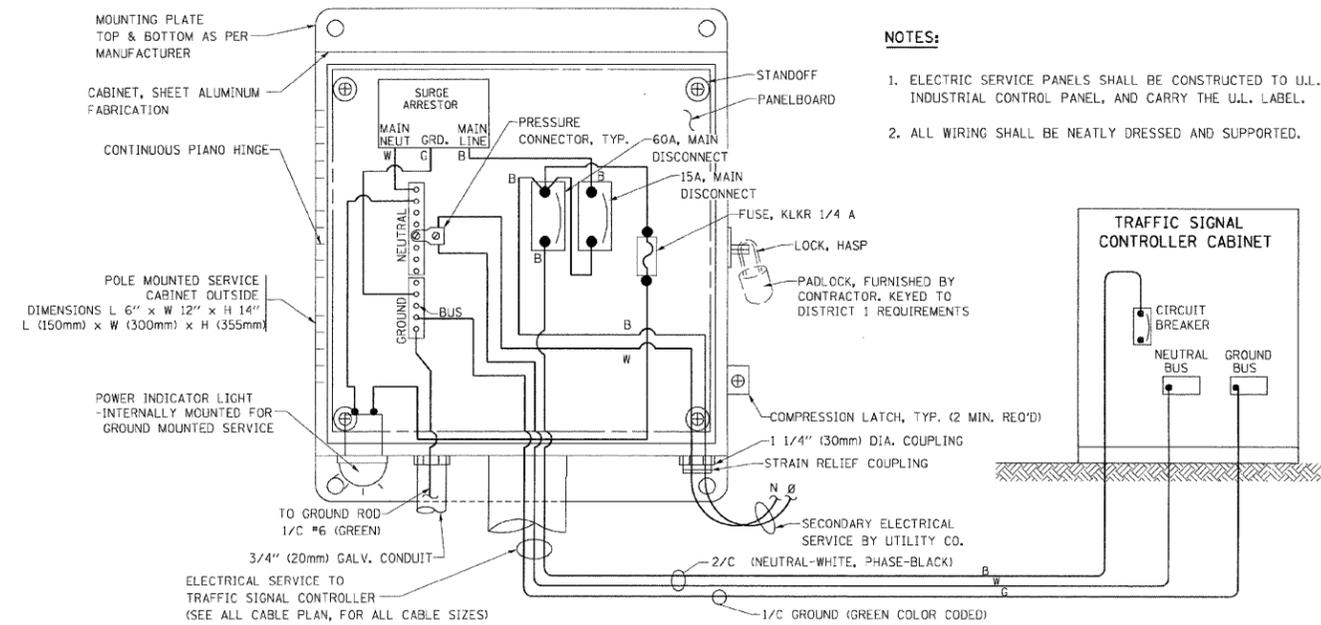

**ELECTRICAL SERVICE - PANEL DIAGRAM (TYPICAL FOR POLE AND GROUND MOUNTED SERVICE)**  
**SERVICE INSTALLATION POLE MOUNT (SHOWN)**  
 (NOT TO SCALE)

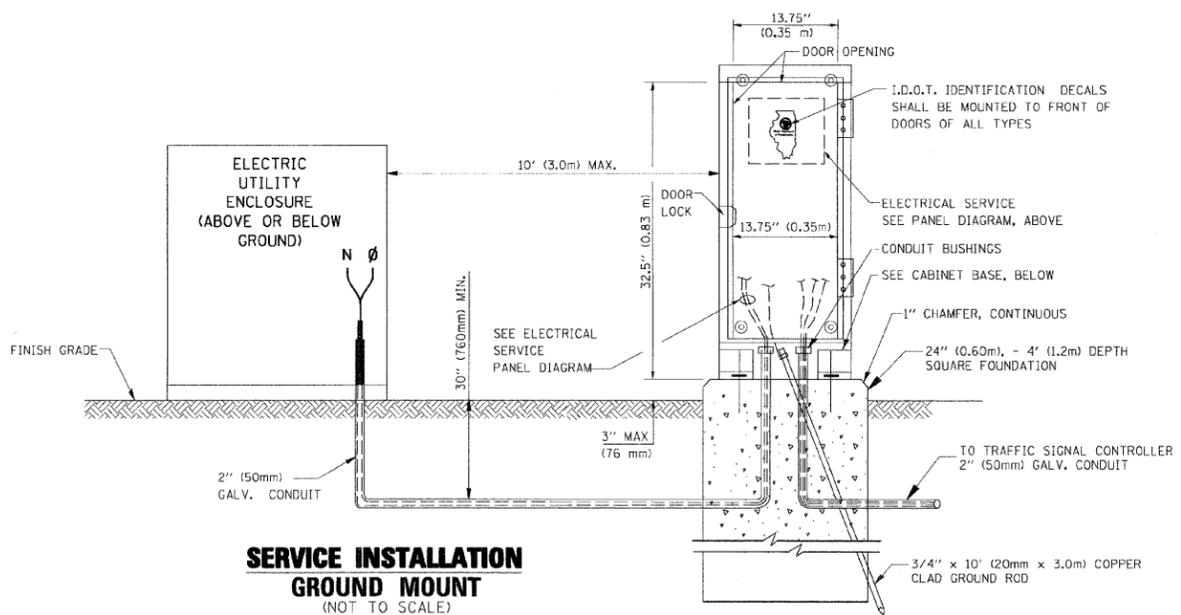

**SERVICE INSTALLATION GROUND MOUNT**  
 (NOT TO SCALE)

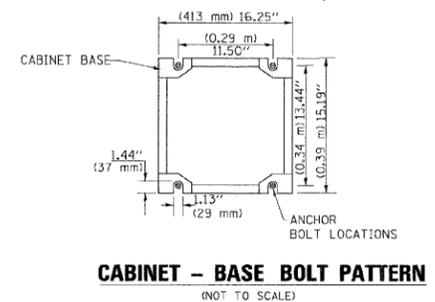

**CABINET - BASE BOLT PATTERN**  
 (NOT TO SCALE)

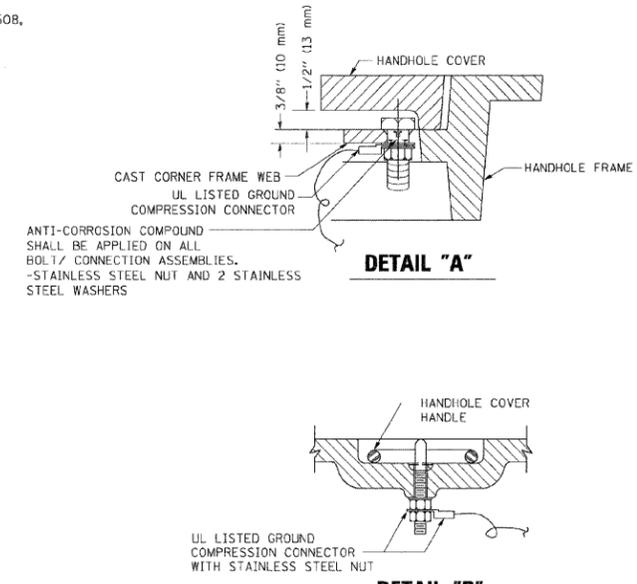

**NOTES:**

**GROUNDING SYSTEM**

- THE GROUNDING SYSTEM SHALL CONSIST OF AN INSULATED CONDUCTOR TYPE XLP, NO. 6 A.W.G., STRANDED COPPER TO BE INSTALLED IN RACEWAYS. THE GROUNDING CABLE SHALL BE INSTALLED IN A CONTINUOUS MANNER AS SHOWN ON THE CABLE PLAN PROVIDED. ALL GROUNDING CONDUCTORS SHALL BE BONDED TO METAL ENCLOSURE (HANDHOLE, POST, MAST ARM, CONTROLLER, ETC.). GROUND ROD SHALL BE 3/4" DIA. x 10'-0" (20mm x 3.0m) LONG, COPPER CLAD. ONE GROUND ROD SHALL BE INSTALLED AT ALL POST FOUNDATIONS, POLE FOUNDATIONS, CONTROLLER CABINET FOUNDATION AND ELECTRICAL SERVICE INSTALLATION AS INDICATED ON THE CABLE PLAN. IF THERE ARE ANY SPECIAL CONDITIONS SUCH AS SUB-SURFACE CONDITIONS OR INSTALLATION PROBLEMS, THE RESIDENT ENGINEER SHALL BE NOTIFIED OR CONTACT THE BUREAU OF TRAFFIC, ILLINOIS DEPARTMENT OF TRANSPORTATION DISTRICT ONE AT (847) 705-4139.
- THE NEUTRAL CONDUCTOR AND THE GROUND CONDUCTOR SHALL BE CONNECTED IN THE SERVICE INSTALLATION. AT NO OTHER POINT IN THE TRAFFIC SIGNAL SYSTEM SHALL THE NEUTRAL AND GROUND CONDUCTORS BE CONNECTED.
- ALL EQUIPMENT GROUNDING CONDUCTORS SHALL TERMINATE AT THE GROUND BUS IN THE CONTROLLER CABINET.
- THE CONTRACTOR SHALL PROVIDE A GROUND CABLE WITH CONNECTORS BETWEEN THE HANDHOLE COVER AND HANDHOLE FRAME.

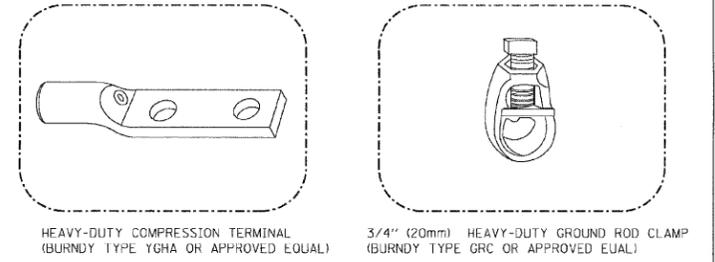

**NOTES:**

- ALL CLAMPS SHALL BE BRONZE OR COPPER, UL APPROVED.
- GROUND CABLE SHALL BE LOOPED OVER HOOKS IN THE HANDHOLES 6.5' (2.0m) SLACK SHALL BE PROVIDED IN SINGLE HANDHOLES 13' (4.0m) OF SLACK SHALL BE PROVIDED IN DOUBLE HANDHOLES. 5' (1.4m) OF SLACK SHALL BE PROVIDED BETWEEN FRAME AND COVER.

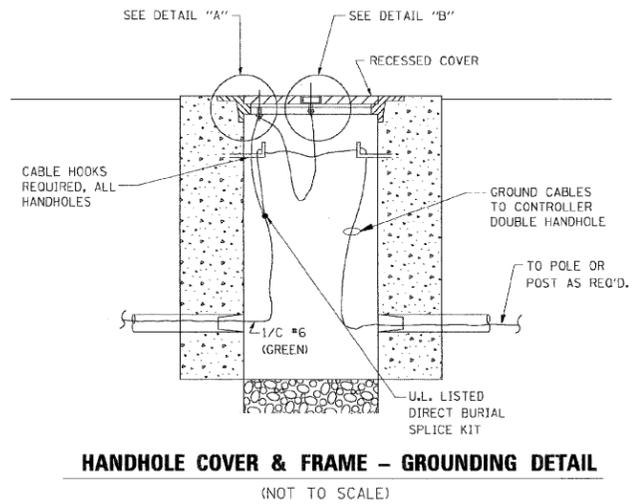

**HANDHOLE COVER & FRAME - GROUNDING DETAIL**  
 (NOT TO SCALE)

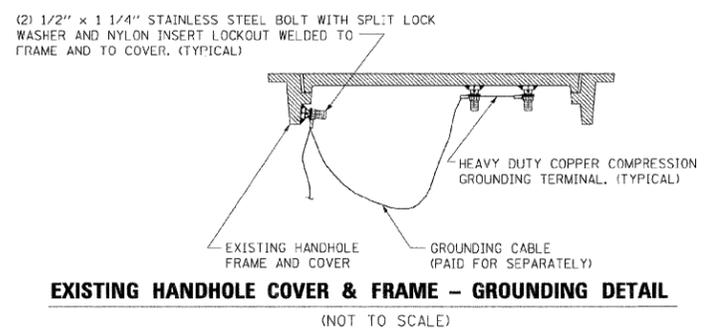

**EXISTING HANDHOLE COVER & FRAME - GROUNDING DETAIL**  
 (NOT TO SCALE)

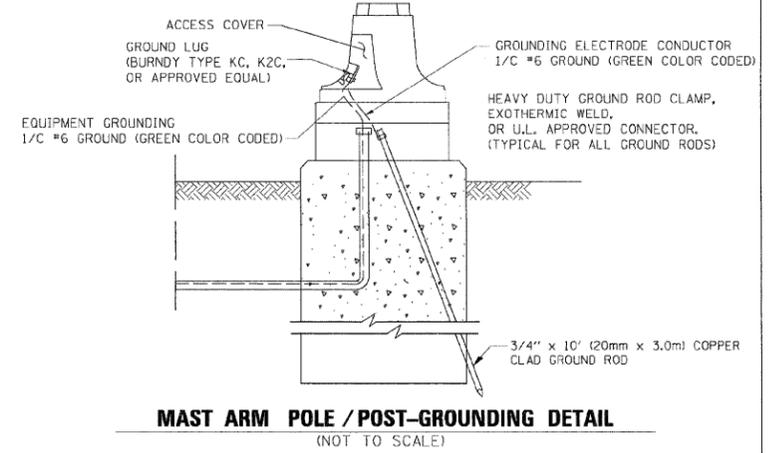

**MAST ARM POLE / POST-GROUNDING DETAIL**  
 (NOT TO SCALE)

REVISIONS	
NAME	DATE
CADD	5/30/00
CADD	3/15/01
BUREAU OF TRAFFIC	1/01/02

ILLINOIS DEPARTMENT OF TRANSPORTATION  
 DISTRICT 1  
 STANDARD TRAFFIC SIGNAL  
 DESIGN DETAILS

SCALE: VERT. NONE  
 HORIZ. DATE 10/18/2002

DRAWN BY: RWP  
 DESIGNED BY: DAD  
 CHECKED BY: DAZ  
 SHEET 3 OF 4

PREPARED BY:  
**CEMCON, Ltd.**  
 Consulting Engineers, Land Surveyors & Planners  
 2280 White Oak Circle, Suite 100  
 Aurora, Illinois 60504-9675  
 Ph: 630.862.2100 Fax: 630.862.2199  
 E-Mail: cadd@cemcon.com Website: www.cemcon.com

10/18/2002  
 c:\projects\diststd\vs05.dgn  
 VIT.S05

FILE NAME = \MICROST\352072\ 06-TS05C	USER NAME = RDS	DESIGNED - KK	REVISED -
PLOT SCALE = 1"=20'	CHECKED - BPT	DRAWN - RDS	REVISED -
PLOT DATE = 03-18-09	DATE - 03-18-09	CHECKED - BPT	REVISED -

**STATE OF ILLINOIS  
 DEPARTMENT OF TRANSPORTATION**

<b>DISTRICT 1 STANDARD TRAFFIC SIGNAL DESIGN DETAILS</b>			
SCALE: N.T.S.	SHEET NO. OF SHEETS	STA. TO STA.	

F.A.P. RTE.	SECTION	COUNTY	TOTAL SHEETS	SHEET NO.
	2009-039 TS	WILL	20	6
CONTRACT NO. 60G44				
FED. ROAD DIST. NO.	ILLINOIS	FED. AID PROJECT		

REVISION DATE: 01/01/02

TS05

F.A. RTE.	SECTION	COUNTY	TOTAL SHEETS	SHEET NO.
STA.	TO STA.			
FED. ROAD DIST. NO.	ILLINOIS	FED. AID PROJECT		

MATERIAL:  
 - ASTM A48 CLASS 30 GREY IRON  
 - ASTM A123 HOT DIPPED GALVANIZED

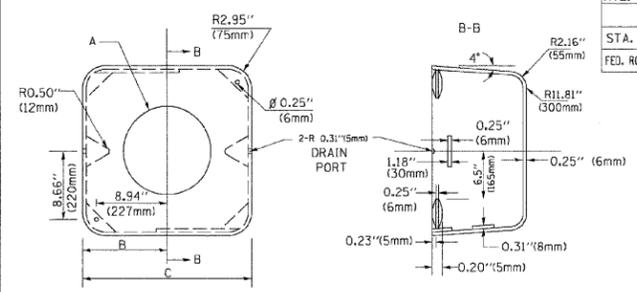

TYPE	A	B	C	HEIGHT	WEIGHT
I	Ø 10.125" (257mm)	9.5" (241mm)	19" (483mm)	12" (300mm)	24kg
II	Ø 11.125" (283mm)	10.75" (273mm)	21.5" (546mm)	12" (300mm)	26kg

SHROUD DETAIL

NOTE:  
 SUPPORT EXISTING CABINET AND CONTROL EQUIPMENT ABOVE FOUNDATION TO KEEP TRAFFIC SIGNAL FUNCTIONING WHILE FOUNDATION MODIFICATION WORK IS PROCEEDING.

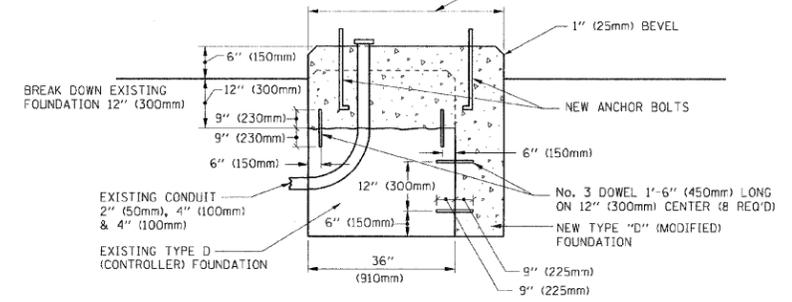

MODIFY EXISTING TYPE "D" FOUNDATION

(NOT TO SCALE)

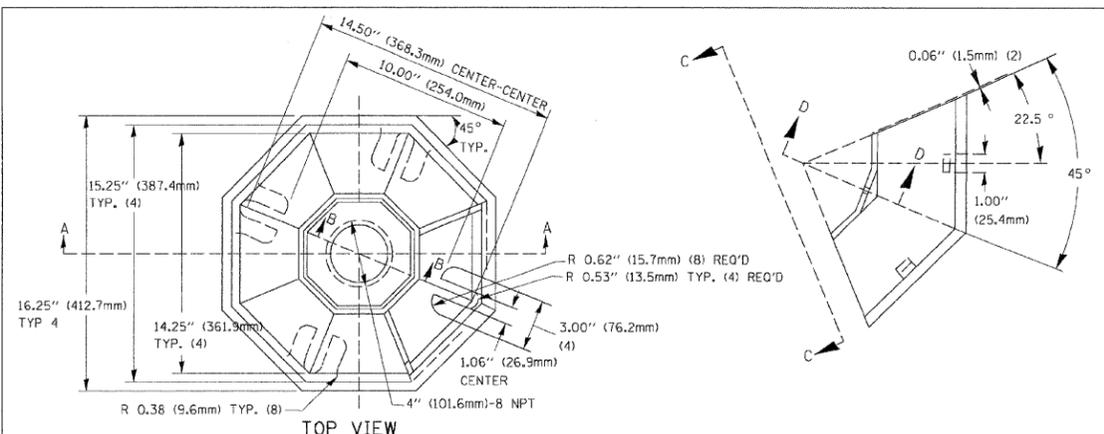

TOP VIEW

SECTION B-B

SECTION D-D

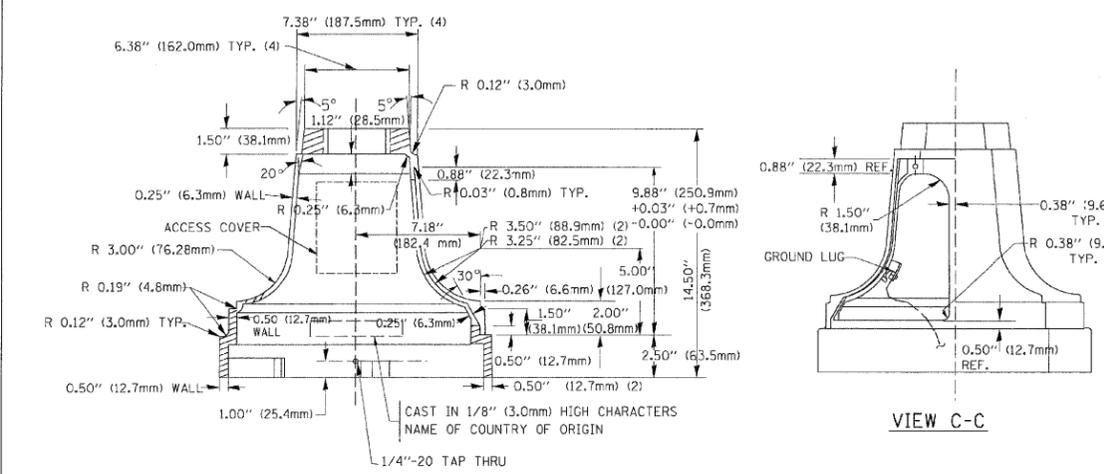

SECTION A-A

VIEW C-C

TRAFFIC SIGNAL POST - MOUNTING BASE - TYPE A

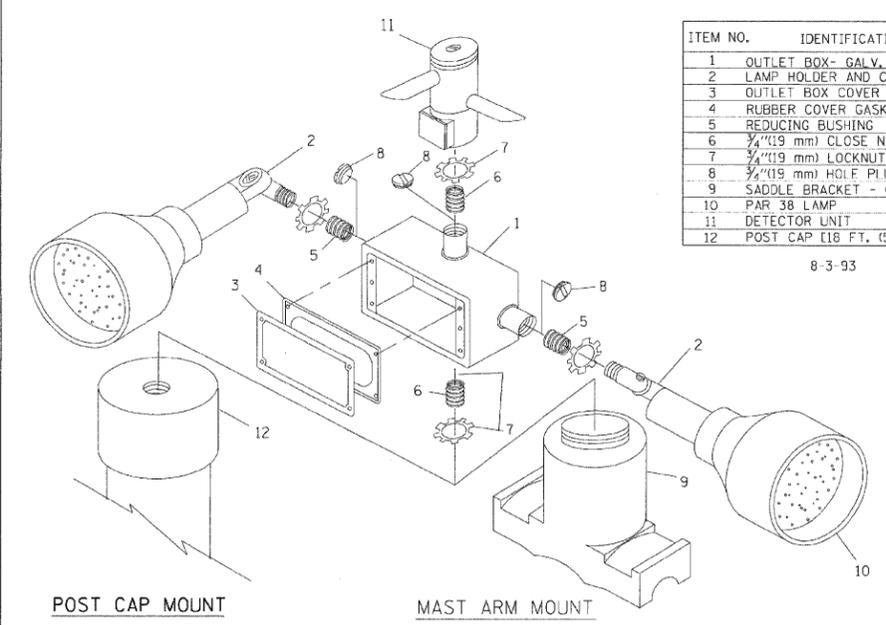

POST CAP MOUNT

MAST ARM MOUNT

EMERGENCY VEHICLE DETECTOR WITH CONFIRMATION BEACON MOUNTING DETAIL

ITEM NO.	IDENTIFICATION
1	OUTLET BOX - GALV. 21 CU. IN. (G.000344 CU-M)
2	LAMP HOLDER AND COVER
3	OUTLET BOX COVER
4	RUBBER COVER GASKET
5	REDUCING BUSHING
6	3/4" (19 mm) CLOSE NIPPLE
7	3/4" (19 mm) LOCKNUT
8	3/4" (19 mm) HOLE PLUG
9	SADDLE BRACKET - GALV.
10	PAR 38 LAMP
11	DETECTOR UNIT
12	POST CAP [18 FT. (5.4 m) POST MIN.]

8-3-93

NOTES:

- ALL ELECTRICAL ITEMS, EXCEPT ITEMS #2 AND #11 SHALL BE ALUMINUM OR GALVANIZED
- ITEM #1- OZ/GEDNEY FSX-1-50 OR EQUIVALENT  
 ITEM #2- MULBERRY CON-O-SHADE LAMP SHIELD OR EQUIVALENT  
 ITEM #9- "BAND-IT" SADDLE BRACKET OR EQUIVALENT
- WHEN POST MOUNTING IS SPECIFIED, ITEM #9 SHALL NOT BE REQUIRED. THE DETECTION UNIT SHALL BE MOUNTED DIRECTLY ON TOP OF THE CAP BY DRILLING AND TAPPING A 3/4" (19 mm) HOLE WITH PIPE THREADS. THE POST CAP SHALL EITHER BE SCREWED TO THE TOP OF THE POST OR A MINIMUM OF 3 TIGHTENING SCREWS SHALL BE REQUIRED ON EACH CAP.

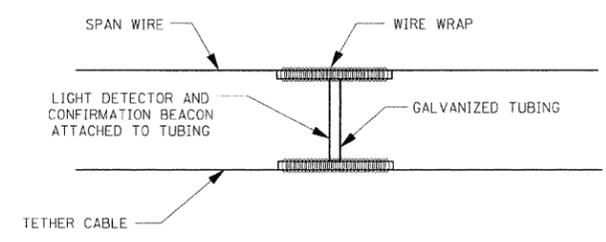

LIGHT DETECTOR AND CONFIRMATION BEACON MOUNTING FOR TEMPORARY TRAFFIC SIGNALS

(NOT TO SCALE)

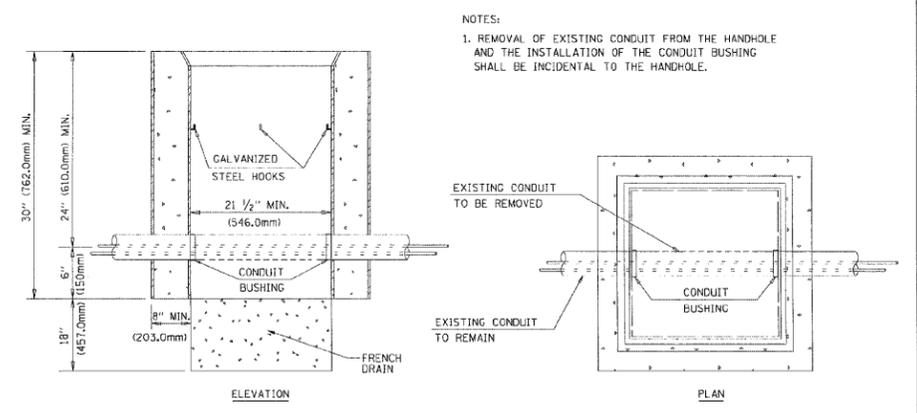

DETAIL HANDHOLE TO INTERCEPT EXISTING CONDUIT

N.T.S.

REVISIONS	NAME	DATE
	BUREAU OF TRAFFIC	5/30/00
	BUREAU OF TRAFFIC	3/15/01
	BUREAU OF TRAFFIC	11/12/01
	BUREAU OF TRAFFIC	1-01-02

ILLINOIS DEPARTMENT OF TRANSPORTATION  
 DISTRICT 1  
 STANDARD TRAFFIC SIGNAL DESIGN DETAILS

SCALE: VERT. NONE  
 HORIZ. DATE 10/18/2002  
 DRAWN BY: RWP  
 DESIGNED BY: DAD  
 CHECKED BY: DAZ  
 SHEET 4 OF 4

TS05

REVISION DATE: 01/01/02

FILE NAME = \\MICROST\352072\07-TS050	USER NAME = RDS	DESIGNED - KK	REVISED -
	PLOT SCALE = 1"=20'	DRAWN - RDS	REVISED -
	PLOT DATE = 03-18-09	CHECKED - BPT	REVISED -
		DATE - 03-18-09	REVISED -

STATE OF ILLINOIS  
 DEPARTMENT OF TRANSPORTATION

DISTRICT 1 STANDARD TRAFFIC SIGNAL DESIGN DETAILS

SCALE: N.T.S. SHEET NO. OF SHEETS STA. TO STA.

F.A.P. RTE.	SECTION	COUNTY	TOTAL SHEETS	SHEET NO.
	2009-039 TS	WILL	20	7
FED. ROAD DIST. NO.	ILLINOIS	FED. AID PROJECT	CONTRACT NO. 60G44	

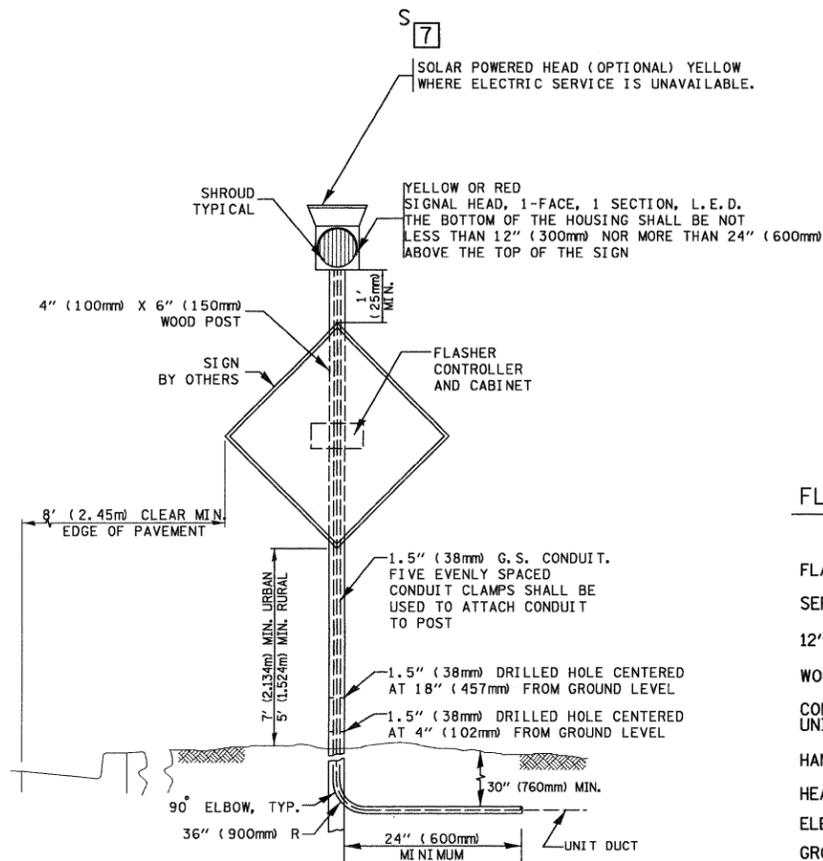

**YELLOW - POST MOUNTED FLASHER DETAIL (TYPICAL)**

**FLASHER SIGNAL LEGEND**

	PROPOSED	EXISTING
FLASHER CONTROL CABINET		
SERVICE INSTALLATION		
12" SIGNAL HEAD (LED)		
WOOD POST, 4" x 6"		
CONDUIT IN GROUND OR UNIT DUCT IN TRENCH		
HANDHOLE		
HEAVY-DUTY HANDHOLE		
ELECTRICAL POLE		
GROUND ROD		
SIGNAL FACE WITH BACKPLATE		
W2-1 OR W2-2 WARNING SIGN W/ STREET PANEL		
JUNCTION BOX - STAINLESS STEEL		

**NOTES:**

REMOVAL OF INCANDESCENT OPTICS ARE INCLUDED IN L.E.D. RETROFIT PAY ITEM

**SCHEDULE OF QUANTITIES**

ITEM	UNIT	QUANTITY
MAINTENANCE OF EXISTING TRAFFIC SIGNAL INSTALLATION	EACH	1
SIGNAL HEAD L.E.D., 1-SECTION, SOLAR POST MOUNTED	EACH	1

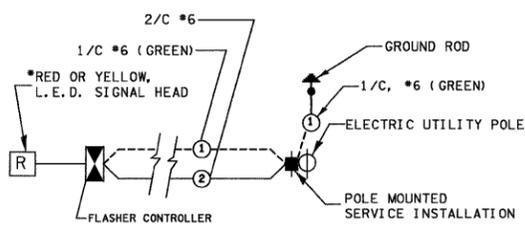

**TYPICAL CABLE PLAN**

- YELLOW FLASHER - MOUNTED IN ADVANCE OF INTERSECTION
- RED FLASHER - MOUNTED AT INTERSECTION

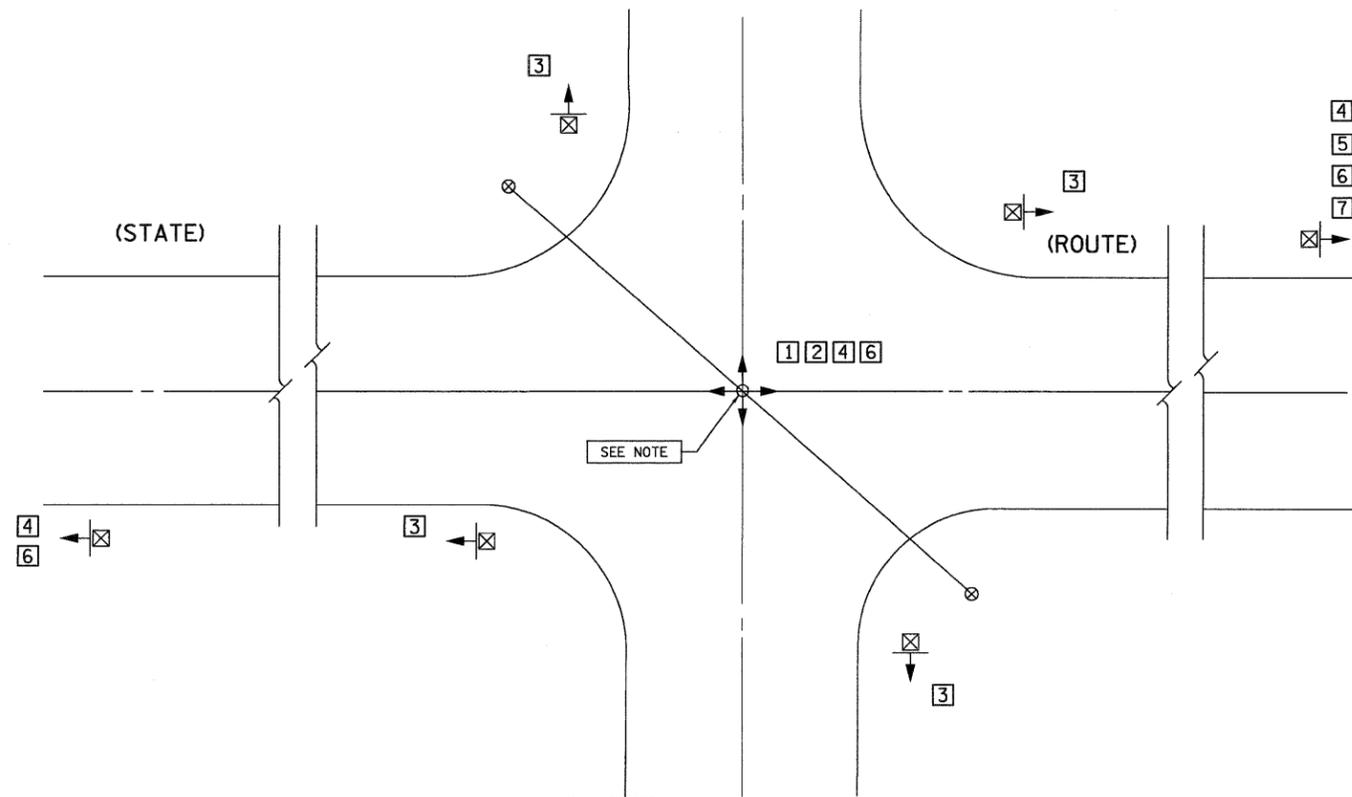

**VARIOUS PLANS - TRAFFIC SIGNAL FLASHERS  
N.T.S.**

- 1 U.S. ROUTE 45/52 @ WILMINGTON/ PEOTONE RD. (VILLAGE OF PEOTONE)
- 2 GOVERNORS HWY. @ STUENKEL RD. (VILLAGE OF UNIVERSITY PARK)
- 3 U.S. ROUTE 52 @ LARAWAY RD. (CITY OF JOLIET)
- 4 U.S. ROUTE 6 @ PARKER RD. (VILLAGE OF MOKENA)
- 5 U.S. ROUTE 6 @ BRANDON RD. (CITY OF JOLIET)
- 6 IL. ROUTE 129 @ STRIP MINE RD. (CITY OF WILMINGTON)
- 7 IL. ROUTE 126 @ ESSINGTON RD. (CITY OF PLAINFIELD)

**L.E.D. FLASHERS - SCHEDULE OF QUANTITIES**

	1	2	3	4	5	6	7
ITEM DESCRIPTION	U.S. RTE. 45/52 @ WILMINGTON PEOTONE RD.	GOVERNOR'S HWY @ STUENKEL ROAD	U.S. RTE. 52 @ LARAWAY ROAD	U.S. RTE. 6 @ PARKER ROAD	U.S. RTE. 6 @ BRANDON ROAD	IL. RTE. 129 @ STRIP MINE RD.	IL. RTE. 126 @ ESSINGTON RD.
TRAFFIC SIGNAL FLASHER 1-SECTION, L.E.D.- (RED)	4	4	4	4		4	
TRAFFIC SIGNAL FLASHER 1-SECTION, L.E.D.- (YELLOW)				2	* 1	2	S <sub>1</sub>

- \* ADVANCED WARNING FLASHER WESTBOUND U.S. ROUTE 6 (IDOT CONTRACT)
- △ ADVANCED WARNING FLASHER(S) NORTH & SOUTHBOUND IL. ROUTE 129 @ STRIP MINE RD.
- ADVANCED WARNING FLASHER(S) EAST & WESTBOUND U.S. ROUTE 6 @ PARKER RD.
- S ADVANCED WARNING FLASHER WESTBOUND (SOLAR POWERED) ON IL. ROUTE 126
- ▨ NOT APPLICABLE THIS LOCATION



IL. RTE. 171 (COLLINS ST.)

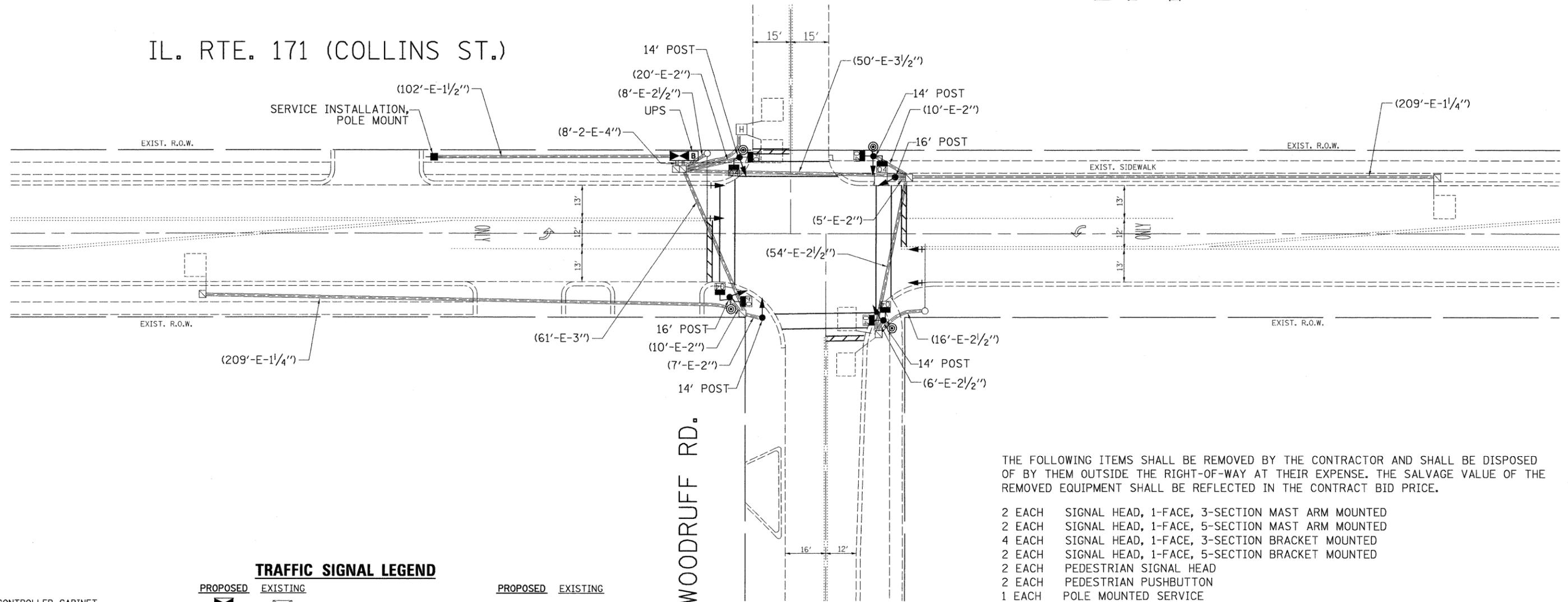

THE FOLLOWING ITEMS SHALL BE REMOVED BY THE CONTRACTOR AND SHALL BE DISPOSED OF BY THEM OUTSIDE THE RIGHT-OF-WAY AT THEIR EXPENSE. THE SALVAGE VALUE OF THE REMOVED EQUIPMENT SHALL BE REFLECTED IN THE CONTRACT BID PRICE.

- 2 EACH SIGNAL HEAD, 1-FACE, 3-SECTION MAST ARM MOUNTED
- 2 EACH SIGNAL HEAD, 1-FACE, 5-SECTION MAST ARM MOUNTED
- 4 EACH SIGNAL HEAD, 1-FACE, 3-SECTION BRACKET MOUNTED
- 2 EACH SIGNAL HEAD, 1-FACE, 5-SECTION BRACKET MOUNTED
- 2 EACH PEDESTRIAN SIGNAL HEAD
- 2 EACH PEDESTRIAN PUSHBUTTON
- 1 EACH POLE MOUNTED SERVICE

**TRAFFIC SIGNAL LEGEND**

	PROPOSED	EXISTING		PROPOSED	EXISTING
CONTROLLER CABINET					
RAILROAD CONTROL CABINET					
SERVICE INSTALLATION, (P) POLE OR (G) GROUND MOUNT					
TELEPHONE CONNECTION					
SIGNAL HEAD					
SIGNAL HEAD WITH BACKPLATE					
SIGNAL HEAD OPTICALLY PROGRAMMED					
SIGNAL HEAD PEDESTRIAN WITH COUNTDOWN TIMER					
ILLUMINATED SIGN "NO LEFT TURN"					
ILLUMINATED SIGN "NO RIGHT TURN"					
SIGNAL POST					
WOOD POLE					
STEEL MAST ARM ASSEMBLY AND POLE					
ALUMINUM MAST ARM ASSEMBLY AND POLE					
STEEL COMBINATION MAST ARM ASSEMBLY AND POLE WITH LUMINAIRE					

**NOTE:**

1. EXISTING TRAFFIC SIGNAL CABLES 2/C & 3/C WILL BE REUSED TO INSTALL THE PEDESTRIAN SIGNAL 2-FACE AT THE LOCATION SHOWN.

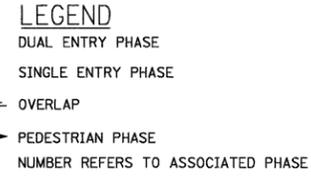
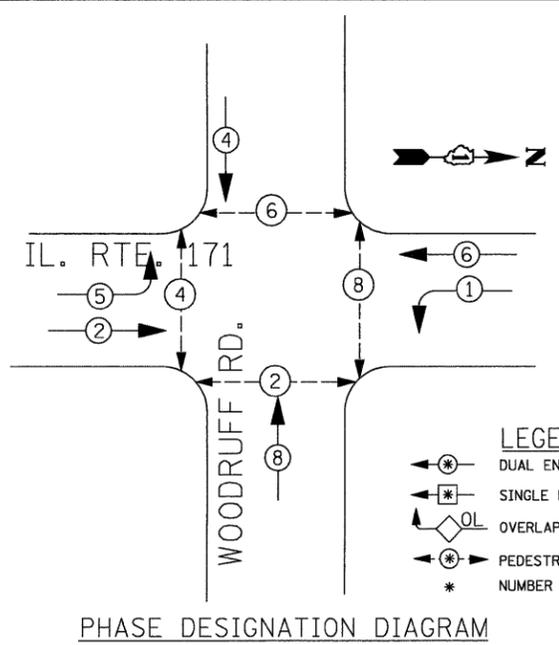

PHASE DESIGNATION DIAGRAM

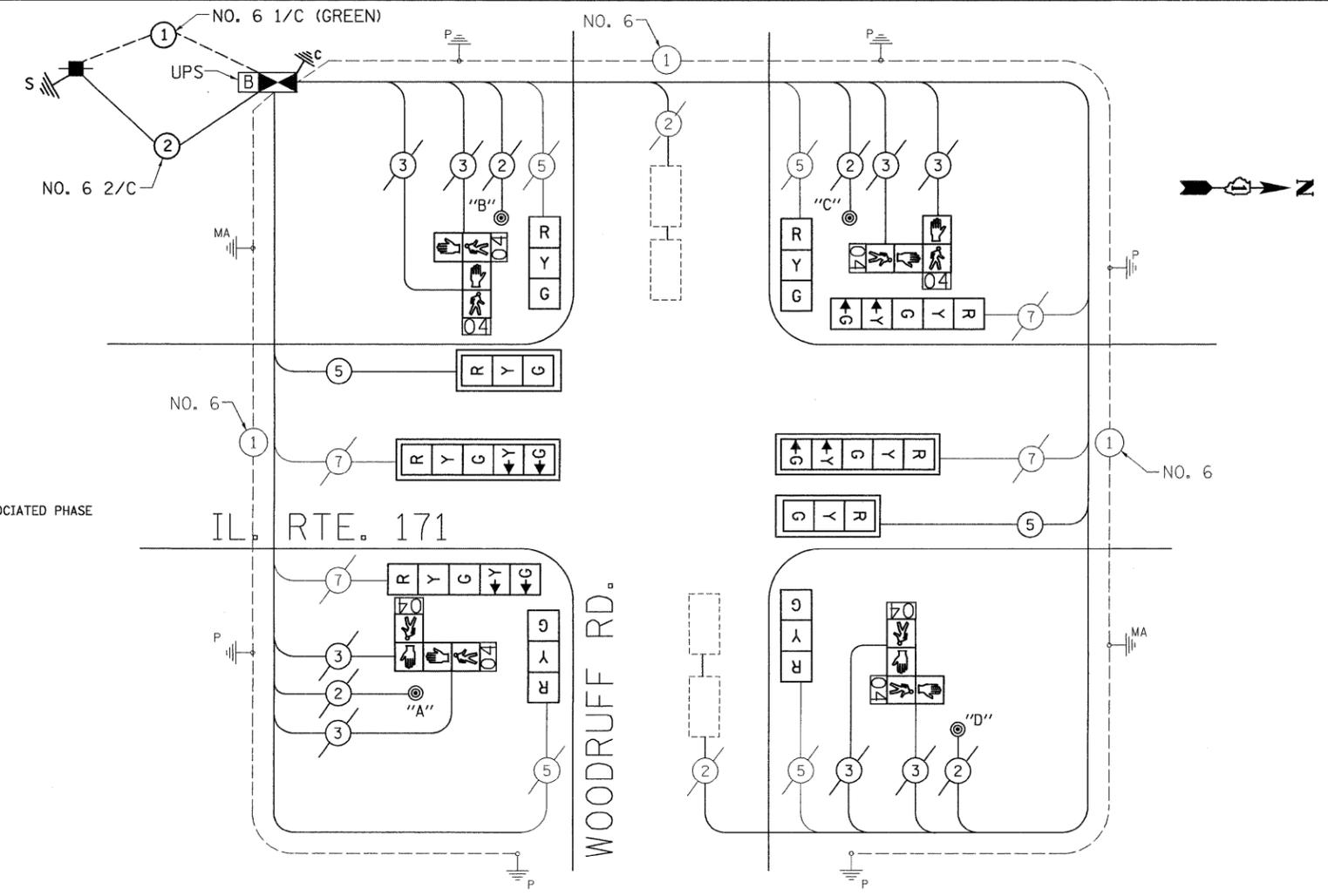

**CABLE PLAN LEGEND**

	PROPOSED	EXISTING
CONTROLLER CABINET		
RAILROAD CONTROL CABINET		
SERVICE INSTALLATION, (P) POLE OR (G) GROUND MOUNT		
TELEPHONE CONNECTION		
GROUND ROD AT (C) CONTROLLER, (H) HANDHOLE, (P) POST, (M) MAST ARM, OR (S) SERVICE		
FIBER OPTIC CABLE IN CONDUIT, NUMBER OF FIBERS AS NOTED		
ELECTRIC CABLE IN CONDUIT, NO. 14, UNLESS OTHERWISE NOTED. NUMBER OF CONDUCTORS AS NOTED		
GROUND CABLE IN CONDUIT NO. 6 COPPER (GREEN)		
SIGNAL FACE WITH BACKPLATE. "P" INDICATES PROGRAMMED HEAD		
12" (300mm) RED WITH 8" (200mm) YELLOW AND GREEN TRAFFIC SIGNAL FACE		
12" (300mm) TRAFFIC SIGNAL SECTION		
12" (300mm) PEDESTRIAN SIGNAL SECTION WITH COUNTDOWN TIMER		
ILLUMINATED SIGN "NO LEFT TURN"		
ILLUMINATED SIGN "NO RIGHT TURN"		
PUSHBUTTON DETECTOR		
DETECTOR LOOP		
PREFORMED DETECTOR LOOP		
MICROWAVE VEHICLE SENSOR		
VIDEO DETECTOR		
CLOSED CIRCUIT TV		
EMERGENCY VEHICLE SYSTEM DETECTOR		
CONFIRMATION BEACON		
UNINTERRUPTABLE POWER SUPPLY		

**SCHEDULE OF QUANTITIES**

ITEM	UNIT	QUANTITY
THERMOPLASTIC PAVEMENT MARKING LINE 6"	FOOT	310
THERMOPLASTIC PAVEMENT MARKING LINE 24"	FOOT	80
MAINTENANCE OF EXISTING TRAFFIC SIGNAL INSTALLATION	EACH	1
FULL-ACTUATED CONTROLLER AND TYPE IV CABINET	EACH	1
ELECTRIC CABLE IN CONDUIT, SIGNAL NO. 14 5C	FOOT	279
ELECTRIC CABLE IN CONDUIT, GROUNDING, NO. 6 1C	FOOT	510
ELECTRIC CABLE IN CONDUIT, SERVICE, NO. 6 2C	FOOT	126
SIGNAL HEAD, L.E.D. 1-FACE, 3 SECTION, MAST ARM MNTD.	EACH	2
SIGNAL HEAD, L.E.D. 1-FACE, 3 SECTION, BRACKET MNTD.	EACH	4
SIGNAL HEAD, L.E.D. 1-FACE, 5 SECTION, MAST ARM. MNTD.	EACH	2
SIGNAL HEAD, L.E.D. 1-FACE, 5 SECTION, BRKT. MNTD.	EACH	2
TRAFFIC SIGNAL POST, GALVANIZED STEEL 14FT.	EACH	4
TRAFFIC SIGNAL POST, GALVANIZED STEEL 16FT.	EACH	2
TRAFFIC SIGNAL BACKPLATE, LOUVERED, ALUMINUM	EACH	4
REMOVE EXISTING TRAFFIC SIGNAL EQUIPMENT	EACH	1
UNINTERRUPTIBLE POWER SUPPLY	EACH	1
SERVICE INSTALLATION, POLE MOUNTED	EACH	1
PEDESTRIAN PUSH-BUTTON	EACH	4
PEDESTRIAN SIGNAL HEAD, L.E.D., 2-FACE, BRKT. MNTD. WITH COUNTDOWN TIMER	EACH	4
THERMOPLASTIC PAVEMENT MARKING REMOVAL	FOOT	90
REMOVE AND REINSTALL ELECTRIC CABLE FROM CONDUIT	FOOT	140

**PUSH BUTTON NOTES:**  
 PUSH BUTTON "A" SHALL PLACE A CALL IN PHASES 2 AND 4  
 PUSH BUTTON "B" SHALL PLACE A CALL IN PHASES 4 AND 6  
 PUSH BUTTON "C" SHALL PLACE A CALL IN PHASES 6 AND 8  
 PUSH BUTTON "D" SHALL PLACE A CALL IN PHASES 2 AND 8

I.D.O.T TRAFFIC SIGNAL INSTALLATION ELECTRICAL SERVICE REQUIREMENTS					TOTAL WATTAGE
TYPE	NO. LAMPS	WATTAGE (INCAND.)	LED	% OPERATION	
SIGNAL (RED)	10	135	17	0.50	85.00
(YELLOW)	10	135	25	0.25	62.50
(GREEN)	10	135	15	0.25	37.50
ARROW	8	135	12	0.10	9.60
PED. SIGNAL	8	90	25	1.00	200.00
CONTROLLER	1	100	100	1.00	100.00
ILLUM. SIGN		84		0.05	
FLASHER				0.50	
ENERGY COSTS TO:					TOTAL = 364.60

FOUNDATION (DEPTH)	FT. (m)	CABLE SLACK	FT. (m)	VERTICAL	FT. (m)
TYPE A - POST	4 (1.2)	HANDHOLE	6.5 (2.0)	ALL FOUNDATIONS	3.5 (1.0)
D - CONTROLLER	4 (1.2)	DOUBLE HANDHOLE	13 (4.0)	MAST ARM (L) POLE	20'-H-2" (6m+L-0.6m)=
E - M. ARM POLE		SIGNAL POST	2 (1.0)	BRACKET MOUNTED	13 (4.0)
		24" (600mm)	10 (3.0)	FIBER OPTIC	13 (4.0)
		30" (750mm)	15 (4.6)	ELECTRIC SERVICE	4 (1.2)
		36" (900mm)	15 (4.6)	ELECTRIC SERVICE	13.5 (4.1)
				GROUND CABLE	13.5 (4.1)
				POST MOUNTED	6 (1.8)

ENERGY SUPPLY CONTACT: PHONE: 708-410-5069 COMPANY: COM. EDISON

DESIGNED - REVISED -  
 DRAWN - REVISED -  
 CHECKED - REVISED -  
 DATE - REVISED -

STATE OF ILLINOIS DEPARTMENT OF TRANSPORTATION

CABLE PLAN, SCHEDULE OF QUANTITIES AND PHASE DESIGNATION DIAGRAM  
 IL. RTE. 171 AT WOODRUFF RD.

F.A. RTE.	SECTION	COUNTY	TOTAL SHEETS	SHEET NO.
	2009-039 TS	WILL	20	10
CONTRACT NO. 60G44				
FED. ROAD DIST. NO. ILLINOIS FED. AID PROJECT				

SCALE: NO SCALE SHEET NO. OF SHEETS STA. TO STA.

**TRAFFIC SIGNAL LEGEND**

PROPOSED	EXISTING	PROPOSED	EXISTING
CONTROLLER CABINET		JUNCTION BOX	
RAILROAD CONTROL CABINET		HANDHOLE	
SERVICE INSTALLATION, (P) POLE OR (G) GROUND MOUNT		HEAVY DUTY HANDHOLE	
TELEPHONE CONNECTION		DOUBLE HANDHOLE	
SIGNAL HEAD		G.S. CONDUIT IN TRENCH OR PUSHED	
SIGNAL HEAD WITH BACKPLATE		COMMON TRENCH	
SIGNAL HEAD OPTICALLY PROGRAMMED		UNIT DUCT	
SIGNAL HEAD PEDESTRIAN WITH COUNTDOWN TIMER		PEDESTRIAN PUSHBUTTON DETECTOR	
ILLUMINATED SIGN "NO LEFT TURN"		DETECTOR LOOP, TYPE I	
ILLUMINATED SIGN "NO RIGHT TURN"		PERFORMED DETECTOR LOOP	
SIGNAL POST		MICROWAVE VEHICLE SENSOR	
WOOD POLE		VIDEO DETECTOR	
STEEL MAST ARM ASSEMBLY AND POLE		CLOSED CIRCUIT TV	
ALUMINUM MAST ARM ASSEMBLY AND POLE		EMERGENCY VEHICLE SYSTEM DETECTOR	
STEEL COMBINATION MAST ARM ASSEMBLY AND POLE WITH LUMINAIRE		CONFIRMATION BEACON	
		UNINTERRUPTIBLE POWER SUPPLY	
		PEDESTRIAN SIGNAL HEAD WITH COUNTDOWN TIMER	

THE FOLLOWING ITEMS SHALL BE REMOVED BY THE CONTRACTOR AND SHALL BE DISPOSED OF BY THEM OUTSIDE THE RIGHT-OF-WAY AT THEIR EXPENCSE. THE SALVAGE VALUE OF THE REMOVED EQUIPMENT SHALL BE REFLECTED IN THE CONTRACT BID PRICE.

- 3 EACH SIGNAL HEAD, 1-FACE, 3-SECTION MAST ARM MOUNTED
- 2 EACH SIGNAL HEAD, 1-FACE, 4-SECTION MAST ARM MOUNTED
- 3 EACH SIGNAL HEAD, 1-FACE, 5-SECTION MAST ARM MOUNTED
- 2 EACH SIGNAL HEAD, 2-FACE, 1-3 SECTION, 1-4 SECTION BRKT. MNTD.
- 1 EACH SIGNAL HEAD, 2-FACE, 5 SECTION BRKT. MNTD.
- 1 EACH SIGNAL HEAD, 2-FACE, 1-3 SECTION, 1-5 SECTION BRKT. MNTD.
- 8 EACH PEDESTRIAN SIGNAL HEAD
- 8 EACH PEDESTRIAN PUSHBUTTON
- 1 EACH POLE MOUNTED SERVICE

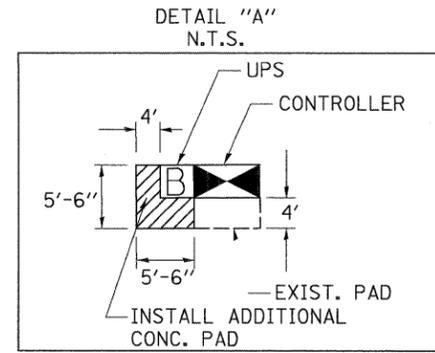

- NOTE:
- 1) 5" THICK CONCRETE PAD SHALL BE POURED NEXT TO NEW CONTROLLER AND /OR UPS TO PROVIDE EASY MAINTENANCE ACCESS.
  - 2) MAINTENANCE PAD SHALL EXTEND TO THE EDGE OF EXISTING CONTROLLER FOUNDATION.
  - 3) COST OF PAD SHALL BE INCLUDED IN THE PRICE OF THE UNINTERRUPTIBLE POWER SUPPLY PAY ITEM.

NOTE:  
THE WORK SHOWN IN DETAIL "A" SHALL BE INCLUDED IN THE COST FOR THE U.P.S. EQUIPMENT.

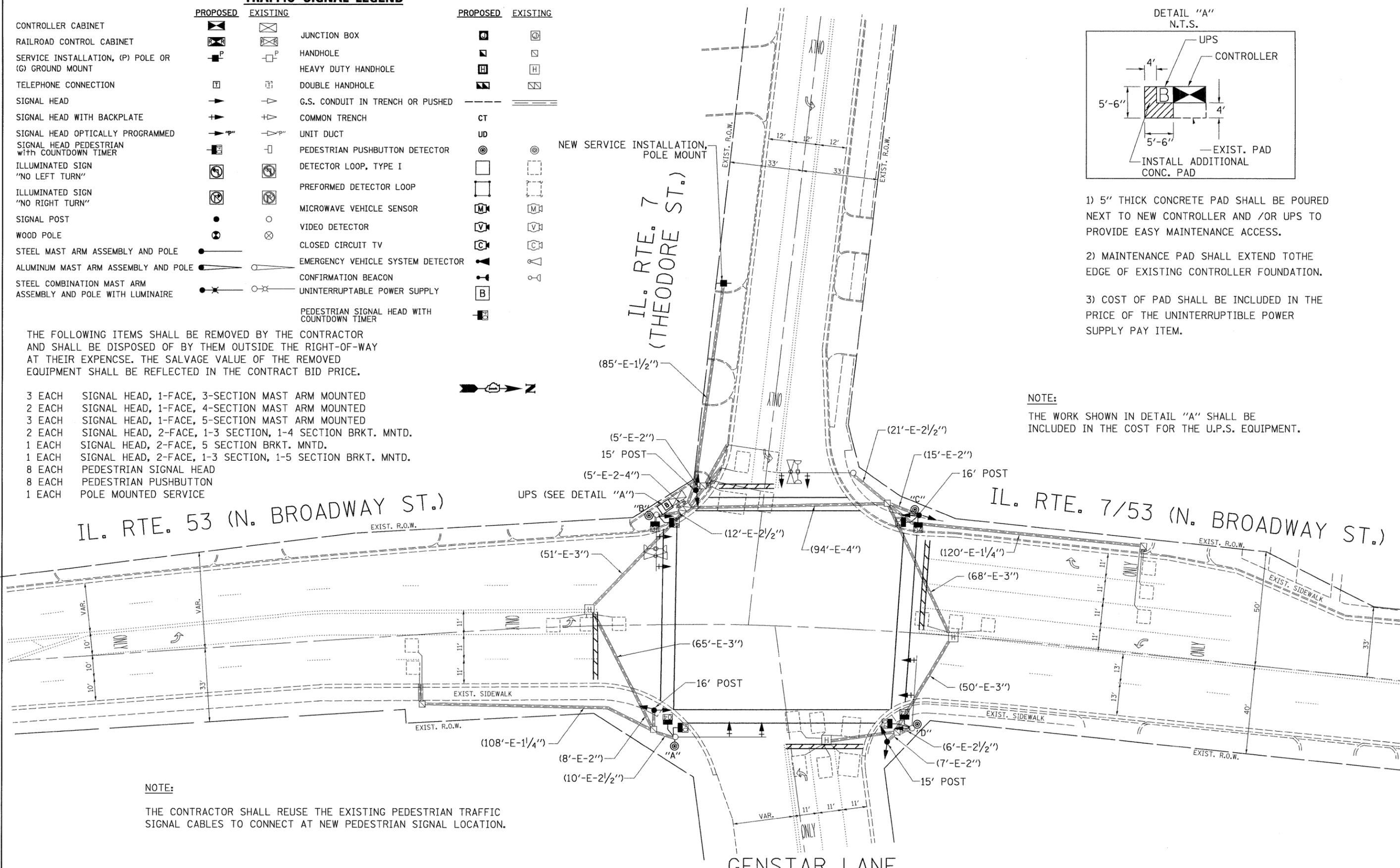

NOTE:  
THE CONTRACTOR SHALL REUSE THE EXISTING PEDESTRIAN TRAFFIC SIGNAL CABLES TO CONNECT AT NEW PEDESTRIAN SIGNAL LOCATION.

FILE NAME = \MICROST\352072\IL53 @THEODORE SIG.DGN	USER NAME =	DESIGNED -	REVISED -	<b>STATE OF ILLINOIS DEPARTMENT OF TRANSPORTATION</b>	<b>TRAFFIC SIGNAL MODERNIZATION PLAN IL. ROUTE. 53 AT IL. ROUTE 7 (THEODORE ST.)</b>			F.A. RTE.	SECTION	COUNTY	TOTAL SHEETS	SHEET NO.
		DRAWN -	REVISED -						2009-039 TS	WILL	20	11
		CHECKED -	REVISED -					CONTRACT NO. 60644				
		DATE -	REVISED -					FED. ROAD DIST. NO. [ILLINOIS] FED. AID PROJECT				
				SCALE: 1"=20'		SHEET NO. OF SHEETS STA. TO STA.						

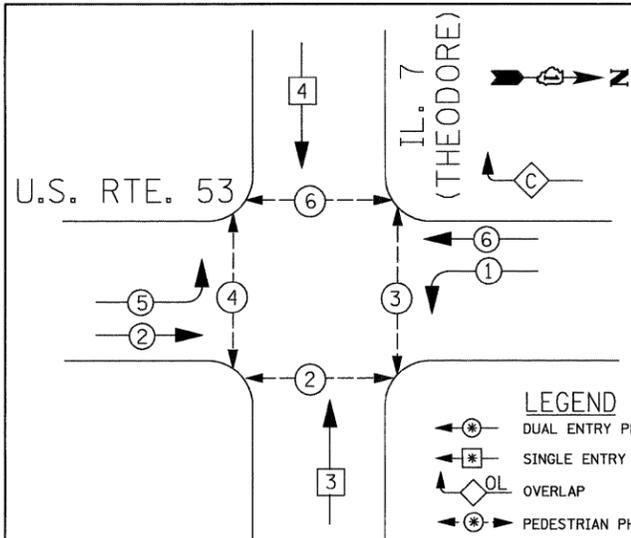

PHASE DESIGNATION DIAGRAM

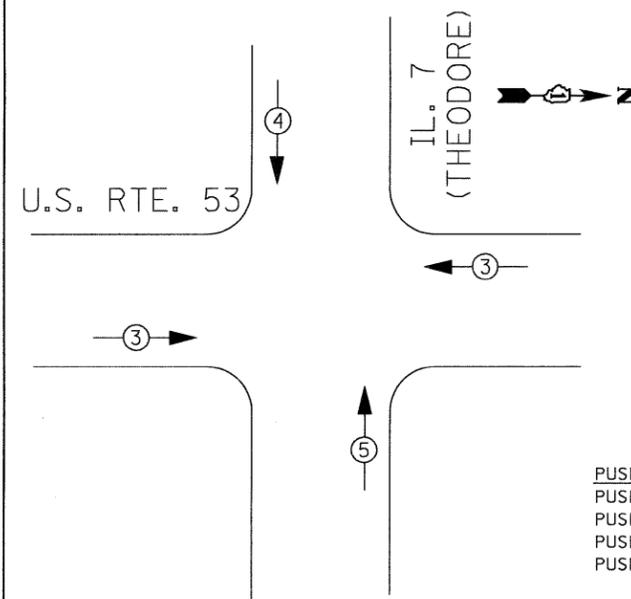

EMERGENCY VEHICLE PREEMPTION SEQUENCE

I.D.O.T. TRAFFIC SIGNAL INSTALLATION ELECTRICAL SERVICE REQUIREMENTS					TOTAL WATTAGE
TYPE	NO. LAMPS	WATTAGE (INCAND.)	WATTAGE (LED)	% OPERATION	
SIGNAL (RED)	14	135	17	0.50	119.00
(YELLOW)	14	135	25	0.25	87.50
(GREEN)	14	135	15	0.25	52.50
ARROW	16	135	12	0.10	19.20
PED. SIGNAL	8	90	25	1.00	200.00
CONTROLLER	1	100	100	1.00	100.00
ILLUM. SIGN		84		0.05	
FLASHER				0.50	
ENERGY COSTS TO:					TOTAL = 578.20

ENERGY SUPPLY CONTACT:  
PHONE: 708-410-5069  
COMPANY: COM. EDISON

FOUNDATION (DEPTH)	FT. (m)	CABLE SLACK	FT. (m)	VERTICAL	FT. (m)
TYPE A - POST	4 (1.2)	HANDHOLE	6.5 (2.0)	ALL FOUNDATIONS	3.5 (1.0)
D - CONTROLLER	4 (1.2)	DOUBLE HANDHOLE	13 (4.0)	MAST ARM (L) POLE	20'+L-2'
E - M. ARM POLE		SIGNAL POST	2 (1.0)	(6m+L-0.6m)=	
	24" (600mm)	CONTROLLER CAB.	1 (0.5)	BRACKET MOUNTED	13 (4.0)
	30" (750mm)	FIBER OPTIC	13 (4.0)	PED. PUSHBUTTON	4 (1.2)
	36" (900mm)	ELECTRIC SERVICE	1 (0.5)	ELECTRIC SERVICE	13.5 (4.1)
		GROUND CABLE	1 (0.5)	SERVICE TO GROUND	13.5 (4.1)
				POST MOUNTED	6 (1.8)

PUSH BUTTON NOTES:

PUSH BUTTON "A" SHALL PLACE A CALL IN PHASES 2 AND 4  
 PUSH BUTTON "B" SHALL PLACE A CALL IN PHASES 4 AND 6  
 PUSH BUTTON "C" SHALL PLACE A CALL IN PHASES 3 AND 6  
 PUSH BUTTON "D" SHALL PLACE A CALL IN PHASES 2 AND 3

EMERGENCY VEHICLE PREEMPTOR	3	4	5
MOVEMENT	→	↓	↑

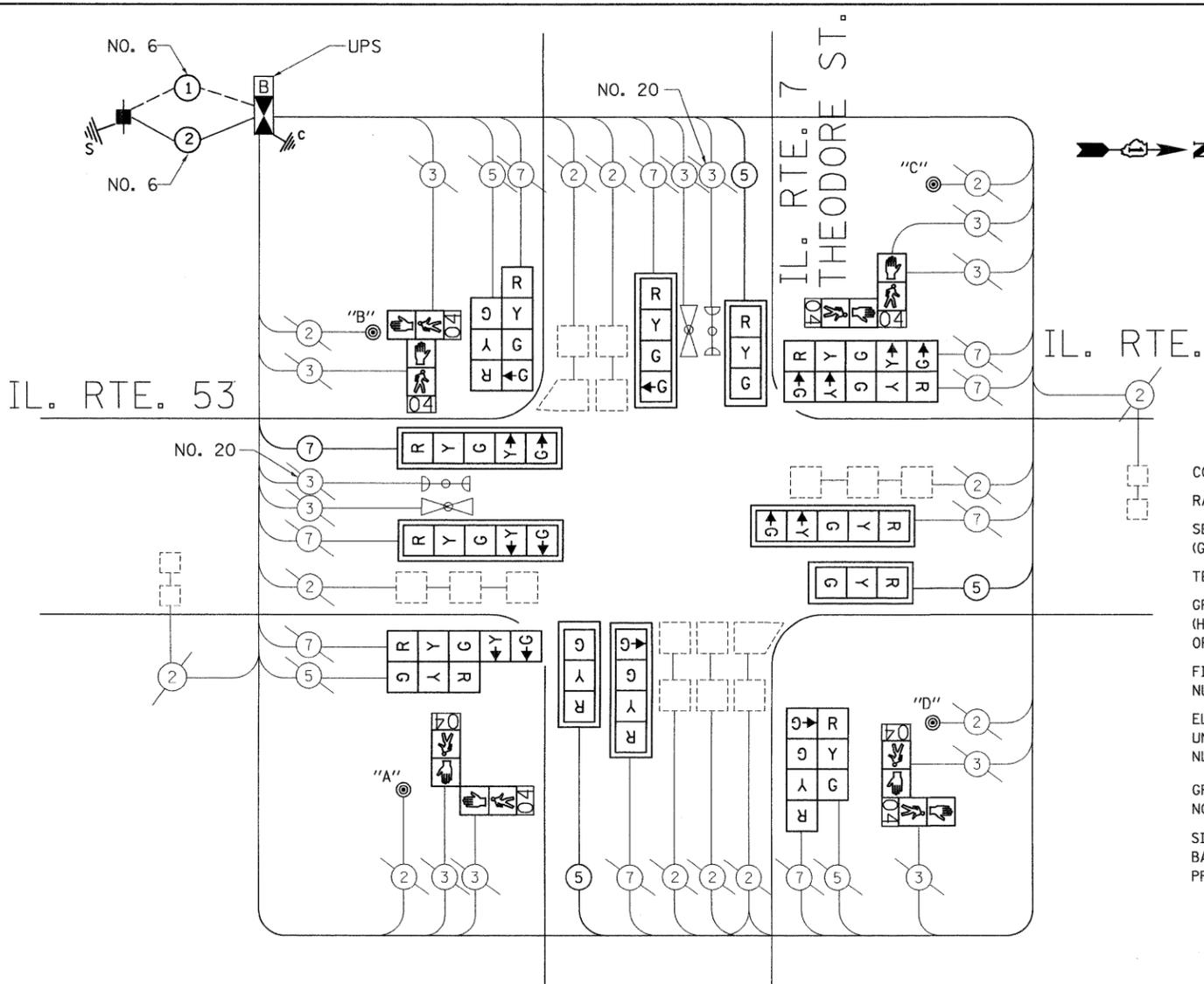

CABLE PLAN LEGEND

	PROPOSED	EXISTING
CONTROLLER CABINET		
RAILROAD CONTROL CABINET		
SERVICE INSTALLATION, (P) POLE OR (G) GROUND MOUNT		
TELEPHONE CONNECTION		
GROUND ROD AT (C) CONTROLLER, (H) HANDHOLE, (P) POST, (M) MAST ARM, OR (S) SERVICE		
FIBER OPTIC CABLE IN CONDUIT, NUMBER OF FIBERS AS NOTED		
ELECTRIC CABLE IN CONDUIT, NO. 14, UNLESS OTHERWISE NOTED. NUMBER OF CONDUCTORS AS NOTED		
GROUND CABLE IN CONDUIT NO. 6 COPPER (GREEN)		
SIGNAL FACE WITH BACKPLATE. "P" INDICATES PROGRAMMED HEAD		
12" (300mm) RED WITH 8" (200mm) YELLOW AND GREEN TRAFFIC SIGNAL FACE		
12" (300mm) PEDESTRIAN SIGNAL SECTION WITH COUNTDOWN TIMER		
ILLUMINATED SIGN "NO LEFT TURN"		
ILLUMINATED SIGN "NO RIGHT TURN"		
PUSHBUTTON DETECTOR		
DETECTOR LOOP		
PREFORMED DETECTOR LOOP		
MICROWAVE VEHICLE SENSOR		
VIDEO DETECTOR		
CLOSED CIRCUIT TV		
EMERGENCY VEHICLE SYSTEM DETECTOR		
CONFIRMATION BEACON		
UNINTERRUPTABLE POWER SUPPLY		

SCHEDULE OF QUANTITIES

ITEM	UNIT	QUANTITY
THERMOPLASTIC PAVEMENT MARKING LINE 6"	FOOT	620
THERMOPLASTIC PAVEMENT MARKING LINE 24"	FOOT	143
MAINTENANCE OF EXISTING TRAFFIC SIGNAL INSTALLATION	EACH	1
ELECTRIC CABLE IN CONDUIT, GROUNDING, NO. 6 1C	FOOT	128
ELECTRIC CABLE IN CONDUIT, SIGNAL, NO. 14 5/C	FOOT	690
ELECTRIC CABLE IN CONDUIT, SIGNAL, NO. 14 7/C	FOOT	65
SIGNAL HEAD, L.E.D. 1-FACE, 3 SECTION, MAST ARM MNTD.	EACH	3
SIGNAL HEAD, L.E.D. 1-FACE, 4 SECTION, MAST ARM. MNTD.	EACH	2
SIGNAL HEAD, L.E.D. 1-FACE, 5 SECTION, MAST ARM. MNTD.	EACH	3
SIGNAL HEAD, L.E.D. 2-FACE, 1-3, 1-4 SECTION, BRKT. MNTD.	EACH	2
SIGNAL HEAD, L.E.D. 2-FACE, 1-3, 1-5 SECTION, BRKT. MNTD.	EACH	1
SIGNAL HEAD, L.E.D. 2-FACE, 5 SECTION, BRKT. MNTD.	EACH	1
TRAFFIC SIGNAL POST, GALVANIZED STEEL 15FT.	EACH	2
TRAFFIC SIGNAL POST, GALVANIZED STEEL 16FT.	EACH	2
TRAFFIC SIGNAL BACKPLATE, LOUVERED, ALUMINUM	EACH	8
REMOVE EXISTING TRAFFIC SIGNAL EQUIPMENT	EACH	1
REMOVE & REINSTALL EXISTING T.S. CABLE	FOOT	162
UNINTERRUPTIBLE POWER SUPPLY	EACH	1
SERVICE INSTALLATION, POLE MOUNTED	EACH	1
PEDESTRIAN PUSH-BUTTON	EACH	4
PEDESTRIAN SIGNAL HEAD, L.E.D., 2-FACE, BRKT. MNTD. WITH COUNTDOWN TIMER	EACH	4
THERMOPLASTIC PAVEMENT MARKING REMOVAL	FOOT	126
ELECTRICAL CABLE IN CONDUIT, SERVICE NO. 6 2C	FOOT	128

THE FOLLOWING ITEMS SHALL BE REMOVED BY THE CONTRACTOR AND SHALL BE DISPOSED OF BY THEM OUTSIDE THE RIGHT-OF-WAY AT THEIR EXPENSE. THE SALVAGE VALUE OF THE REMOVED EQUIPMENT SHALL BE REFLECTED IN THE CONTRACT BID PRICE.

- 1 EACH CONTROLLER
- 5 EACH SIGNAL HEAD, 1-FACE, 3-SECTION
- 2 EACH SIGNAL HEAD, 1-FACE, 5-SECTION
- 1 EACH SIGNAL HEAD, 2-FACE, 3-SECTION
- 2 EACH TRAFFIC SIGNAL BACKPLATE
- 3 EACH TRAFFIC SIGNAL POST
- 2 EACH COMBINATION MAST ARM ASSEMBLY AND POLE
- 1 EACH SERVICE INSTALLATION

**NOTE:**  
RELOCATE EXISTING MAST ARM MOUNTED SIGNS TO NEW MAST ARM.

**SIGN "A"**



R10-11B  
30"x 30"

**SIGN "B"**



R1-1  
30"x 30"

(HORIZONTAL FOLDING SIGN WITH "DRIVE CAREFULLY" MESSAGE ON BACK WHEN FOLDED)

**DETAIL "B"**

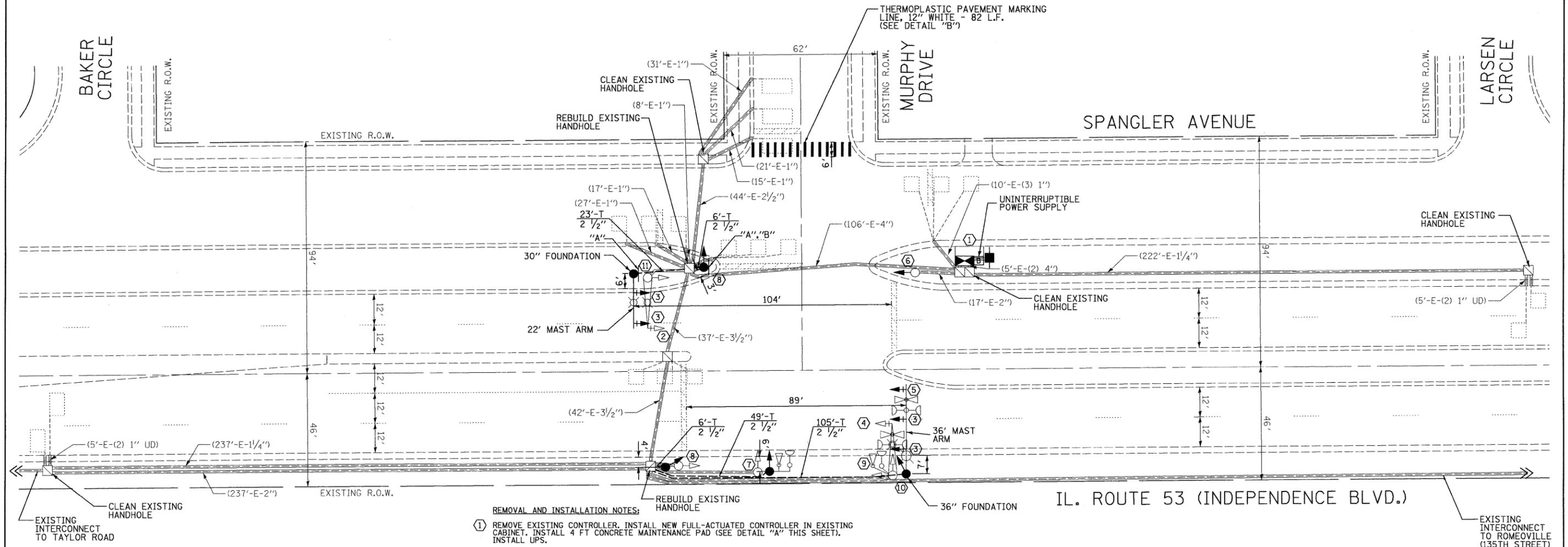
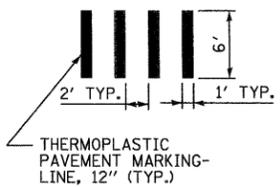

**REMOVAL AND INSTALLATION NOTES:**

- 1) REMOVE EXISTING CONTROLLER. INSTALL NEW FULL-ACTUATED CONTROLLER IN EXISTING CABINET. INSTALL 4 FT CONCRETE MAINTENANCE PAD (SEE DETAIL "A" THIS SHEET). INSTALL UPS.
- 2) REMOVE EXISTING SIGNAL HEAD, 1-FACE 3-SECTION, MAST ARM MOUNTED.
- 3) INSTALL NEW SIGNAL HEAD, LED, 1-FACE 3-SECTION, MAST ARM MOUNTED.
- 4) REMOVE EXISTING SIGNAL HEAD, 1-FACE 5-SECTION, MAST ARM MOUNTED.
- 5) INSTALL NEW SIGNAL HEAD, LED, 1-FACE 5-SECTION, MAST ARM MOUNTED.
- 6) REMOVE EXISTING SIGNAL HEAD, 1-FACE 5-SECTION, BRACKET MOUNTED. INSTALL NEW SIGNAL HEAD, LED, 1-FACE 5-SECTION, BRACKET MOUNTED.
- 7) REMOVE EXISTING SIGNAL HEAD, 1-FACE 3-SECTION, BRACKET MOUNTED. REMOVE EXISTING TRAFFIC SIGNAL POST AND EXISTING CONCRETE FOUNDATION. INSTALL NEW TRAFFIC SIGNAL POST, 18 FT ON NEW FOUNDATION AT PROPOSED LOCATION AS SHOWN IN PLAN. INSTALL NEW SIGNAL HEAD, LED, 1-FACE 3-SECTION, BRACKET MOUNTED.
- 8) REMOVE EXISTING SIGNAL HEAD, 1-FACE 3-SECTION, BRACKET MOUNTED. REMOVE EXISTING TRAFFIC SIGNAL POST AND EXISTING CONCRETE FOUNDATION. INSTALL NEW TRAFFIC SIGNAL POST, 14 FT ON NEW FOUNDATION AT PROPOSED LOCATION AS SHOWN IN PLAN. INSTALL NEW SIGNAL HEAD, LED, 1-FACE 3-SECTION, BRACKET MOUNTED.
- 9) REMOVE AND REINSTALL EXISTING EMERGENCY VEHICLE PREEMPTION LIGHT DETECTOR AND CONFIRMATION BEACON ON 18 FT TRAFFIC SIGNAL POST AS SHOWN IN PLAN.
- 10) REMOVE EXISTING SIGNAL HEAD, 2-FACE, 3-SECTION, BRACKET MOUNTED. REMOVE AND REINSTALL EXISTING EMERGENCY VEHICLE PREEMPTION LIGHT DETECTOR AND CONFIRMATION BEACON ON NEW MAST ARM. REMOVE AND REINSTALL EXISTING LUMINAIRE ON NEW COMBINATION POLE. REMOVE EXISTING COMBINATION POLE. REMOVE EXISTING CONCRETE FOUNDATION. INSTALL NEW STEEL COMBINATION MAST ARM ASSEMBLY AND POLE, 36 FT ON NEW FOUNDATION AT PROPOSED LOCATION AS SHOWN IN PLAN. INSTALL NEW SIGNAL HEAD, LED, 1-FACE, 3-SECTION, BRACKET MOUNTED.
- 11) REMOVE EXISTING SIGNAL HEAD, 1-FACE 3-SECTION, BRACKET MOUNTED. REMOVE AND REINSTALL EXISTING LUMINAIRE ON NEW COMBINATION POLE. REMOVE EXISTING COMBINATION POLE. REMOVE EXISTING CONCRETE FOUNDATION. INSTALL NEW STEEL COMBINATION MAST ARM ASSEMBLY AND POLE, 22 FT ON NEW FOUNDATION AT PROPOSED LOCATION AS SHOWN IN PLAN.

**DETAIL "A"**

N.T.S.

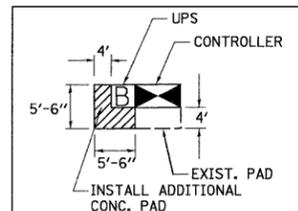

1) 5" THICK CONCRETE PAD SHALL BE POURED NEXT TO NEW CONTROLLER AND/OR UPS TO PROVIDE EASY MAINTENANCE ACCESS.

2) MAINTENANCE PAD SHALL EXTEND TO THE EDGE OF EXISTING CONTROLLER FOUNDATION.

3) COST OF PAD SHALL BE INCLUDED IN THE PRICE OF THE UNINTERRUPTIBLE POWER SUPPLY PAY ITEM.

**NOTE:**

THE WORK SHOWN IN DETAIL "A" SHALL BE INCLUDED IN THE COST FOR THE U.P.S. EQUIPMENT.

**NOTE:**  
THE TRAFFIC SIGNAL CONTROL EQUIPMENT FOR THIS PROJECT SHALL BE "ECONOLITE" TO MATCH THE EXISTING ADJACENT SYSTEM.

**NOTE:**  
CONTRACTOR SHALL REINSTALL "EVP" EQUIPMENT WHERE SHOWN TO NEW MAST ARM OR TRAFFIC SIGNAL POST AND CONTROLLER. THIS WORK SHALL BE INCLUDED IN COST FOR "FULL-ACTUATED CONTROLLER IN EXISTING CABINET, SPECIAL".

**NOTE:**  
THE CONTRACTOR SHALL BE REQUIRED TO MAINTAIN THE OPERATION OF THE TRAFFIC SIGNALS DURING THE ENTIRE PROJECT.

**TRAFFIC SIGNAL LEGEND**

	PROPOSED	EXISTING		PROPOSED	EXISTING
CONTROLLER			CONFIRMATION BEACON		
SERVICE INSTALLATION			SIGNAL HEAD OPTICALLY PROGRAMMED		
SIGNAL HEAD			CONDUIT SPLICE		
SIGNAL HEAD WITH BACKPLATE			WOOD POLE		
SIGNAL HEAD, PEDESTRIAN			RACEWAY FOR MAGNETIC DETECTOR, TYPE I OR TYPE II		
SIGNAL POST			VEHICLE DETECTOR, NON COMPENSATED MAGNETIC TYPE		
STEEL MAST ARM ASSEMBLY AND POLE			RAILROAD CONTROL CABINET		
MAST ARM ASSEMBLY AND POLE, ALUMINUM			TELEPHONE CONNECTION		
STEEL COMBINATION MAST ARM ASSEMBLY AND POLE WITH LUMINAIRE			ILLUMINATED SIGN "NO LEFT TURN"		
UNIT DUCT	UD		ILLUMINATED SIGN "NO RIGHT TURN"		
COMMON TRENCH	CT		UNINTERRUPTIBLE POWER SUPPLY		
HANDHOLE					
HEAVY DUTY HANDHOLE					
DOUBLE HANDHOLE					
G.S. CONDUIT IN TRENCH (T) OR PUSHED (P)					
PEDESTRIAN PUSH-BUTTON DETECTOR					
DETECTOR LOOP, TYPE I					
CAST IRON JUNCTION BOX					
EMERGENCY VEHICLE SYSTEM DETECTOR					

FILE NAME =	USER NAME = RDS	DESIGNED - KK	REVISED -
\\MICROST\352072\ RT53 @ MURPHY SIG.DGN		DRAWN - RDS	REVISED -
	PLOT SCALE = 1"=20'	CHECKED - BPT	REVISED -
	PLOT DATE = 03-18-09	DATE - 03-18-09	REVISED -

**STATE OF ILLINOIS  
DEPARTMENT OF TRANSPORTATION**

<b>TRAFFIC SIGNAL MODIFICATION PLAN IL. ROUTE 53 (INDEPENDENCE BLVD.) AT MURPHY DRIVE</b>			
SCALE: N.T.S.	SHEET NO. OF SHEETS	STA. TO STA.	

PREPARED BY:  
**CEMCON, Ltd.**  
Consulting Engineers, Land Surveyors & Planners  
2280 White Oak Circle, Suite 100  
Aurora, Illinois 60504-9675  
Ph: 630.862.2100 Fax: 630.862.2199  
E-Mail: codd@cemcon.com Website: www.cemcon.com

F.A.P. RTE.	SECTION	COUNTY	TOTAL SHEETS	SHEET NO.
	2009-039 TS	WILL	20	13
				CONTRACT NO. 60G44
FED. ROAD DIST. NO.		ILLINOIS FED. AID PROJECT		

**CONTROLLER SEQUENCE**

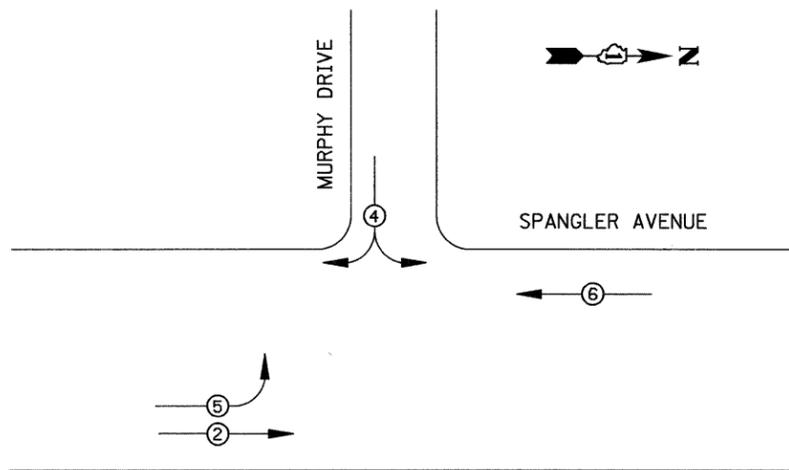

IL. ROUTE 53  
(INDEPENDENCE BLVD.)

**LEGEND**

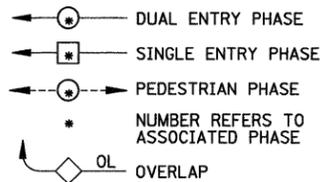

**PHASE DESIGNATION DIAGRAM**

EMERGENCY VEHICLE PREEMPTION SEQUENCE

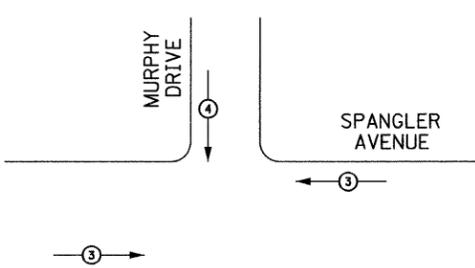

IL. ROUTE 53  
(INDEPENDENCE BLVD.)

**PROPOSED EMERGENCY VEHICLE PREEMPTOR**

EMERGENCY VEHICLE PREEMPTOR	3	4
MOVEMENT	← →	↓

**CABLE PLAN LEGEND**

- EXISTING PROPOSED
- 8" (200mm) TRAFFIC SIGNAL SECTION
- 12" (300mm) TRAFFIC SIGNAL SECTION
- 12" (300mm) PEDESTRIAN SIGNAL SECTION
- 12" (300mm) PEDESTRIAN SIGNAL SECTION
- CONTROLLER CABINET
- SERVICE INSTALLATION
- TELEPHONE CONNECTION
- MAGNETIC DETECTOR
- EMERGENCY VEHICLE LIGHT DETECTOR
- CONFIRMATION BEACON
- PUSH-BUTTON DETECTOR
- VEHICLE DETECTOR, INDUCTION LOOP
- DENOTES NUMBER OF CONDUCTORS, ALL CABLE NO. 14 EXCEPT AS INDICATED. ALL LOOP DETECTOR CABLE TO BE SHIELDED.
- GROUND CABLE IN CONDUIT NO. 6 SOLID COPPER (GREEN)
- FIBER OPTIC CABLE IN CONDUIT NO. 62.5/125 2-MM12F SMI2F
- SIGNAL FACE WITH BACKPLATE, "P" INDICATES PROGRAMMED HEAD
- RAILROAD CONTROL CABINET
- ILLUMINATED SIGN "NO LEFT TURN"
- ILLUMINATED SIGN "NO RIGHT TURN"
- GROUND ROD AT HANDHOLE (H), DOUBLE HANDHOLE (HH), OR CONTROLLER (C)
- GROUND ROD AT POST (P), OR MAST ARM POLE (MA)
- GROUND ROD AT ELECTRIC SERVICE INSTALLATION
- UNINTERRUPTIBLE POWER SUPPLY

**SCHEDULE OF QUANTITIES**

SIGN PANEL, TYPE 1	SQ FT	19
RELOCATE SIGN PANEL, TYPE 1	SQ FT	12
THERMOPLASTIC PAVEMENT MARKING, LINE-12"	FOOT	82
CONDUIT IN TRENCH, 2 1/2" DIA., GALVANIZED STEEL	FOOT	189
TRENCH AND BACKFILL FOR ELECTRICAL WORK	FOOT	194
MAINTENANCE OF EXISTING TRAFFIC SIGNAL INSTALLATION	EACH	1
FULL-ACTUATED CONTROLLER IN EXISTING CABINET, SPECIAL	EACH	1
ELECTRIC CABLE IN CONDUIT, SIGNAL NO. 14 3C	FOOT	1225
ELECTRIC CABLE IN CONDUIT, SIGNAL NO. 14 5C	FOOT	2137
ELECTRIC CABLE IN CONDUIT, SIGNAL NO. 14 7C	FOOT	478
ELECTRIC CABLE IN CONDUIT, SERVICE, NO. 6 2C	FOOT	19
ELECTRIC CABLE IN CONDUIT, LEAD-IN, NO. 14 1 PAIR	FOOT	1352
TRAFFIC SIGNAL POST, GALVANIZED STEEL 14 FT.	EACH	2
TRAFFIC SIGNAL POST, GALVANIZED STEEL 18 FT.	EACH	1
STEEL COMBINATION MAST ARM ASSEMBLY AND POLE 22 FT.	EACH	1
STEEL COMBINATION MAST ARM ASSEMBLY AND POLE 36 FT.	EACH	1
CONCRETE FOUNDATION, TYPE A 30-INCH DIAMETER	FOOT	12
CONCRETE FOUNDATION, TYPE A 36-INCH DIAMETER	FOOT	15
SIGNAL HEAD, LED, 1-FACE, 3-SECTION, MAST-ARM MOUNTED	EACH	4
SIGNAL HEAD, LED, 1-FACE, 3-SECTION, BRACKET MOUNTED	EACH	4
SIGNAL HEAD, LED, 1-FACE, 5-SECTION, BRACKET MOUNTED	EACH	1
SIGNAL HEAD, LED, 1-FACE, 5-SECTION, MAST-ARM MOUNTED	EACH	1
TRAFFIC SIGNAL BACKPLATE, LOUVERED, ALUMINUM	EACH	5
REMOVE ELECTRIC CABLE FROM CONDUIT	FOOT	5189
REMOVE EXISTING TRAFFIC SIGNAL EQUIPMENT	EACH	1
REMOVE EXISTING CONCRETE FOUNDATION	EACH	4
CLEAN EXISTING ELECTRICAL MANHOLE OR HANDHOLE	EACH	4
SERVICE INSTALLATION, POLE MOUNT	EACH	1
RELOCATE EXISTING LUMINAIRE	EACH	2
ELECTRIC CABLE IN CONDUIT, GROUNDING, NO. 6 1C	FOOT	431
ELECTRIC CABLE IN CONDUIT, NO. 20 3/C, TWISTED & SHIELDED	FOOT	650
UNINTERRUPTIBLE POWER SUPPLY	EACH	1
REBUILD EXISTING HANDHOLE	EACH	2

FOUNDATION (DEPTH)	FT. (m)	CABLE SLACK	FT. (m)	VERTICAL	FT. (m)
TYPE A - POST	4 (1.2)	HANDHOLE	6.5 (2.0)	ALL FOUNDATIONS	3.0 (1.0)
D - CONTROLLER	4 (1.2)	DOUBLE HANDHOLE	13 (4.0)	MAST ARM (L) POLE	20.0 (6.0)
E - M. ARM POLE		SIGNAL POST	0 (0.0)	BRACKET MOUNTED	13 (4.0)
24" (600mm)	10 (3.0)	CONTROLLER CAB.	0 (0.0)	PED. PUSH-BUTTON	6 (2.0)
30" (750mm)	15 (4.6)	FIBER OPTIC	13 (4.0)	ELECTRIC SERVICE	13.5 (4.1)
		ELECTRIC SERVICE	1 (0.5)	SERVICE TO GROUND	13.5 (4.1)
		GROUND CABLE	1 (0.5)	POST MOUNTED	13 (4.0)

NOTE:  
THE TRAFFIC SIGNAL CONTROL EQUIPMENT FOR THIS PROJECT SHALL BE "ECONOLITE" TO MATCH THE EXISTING ADJACENT SYSTEM.

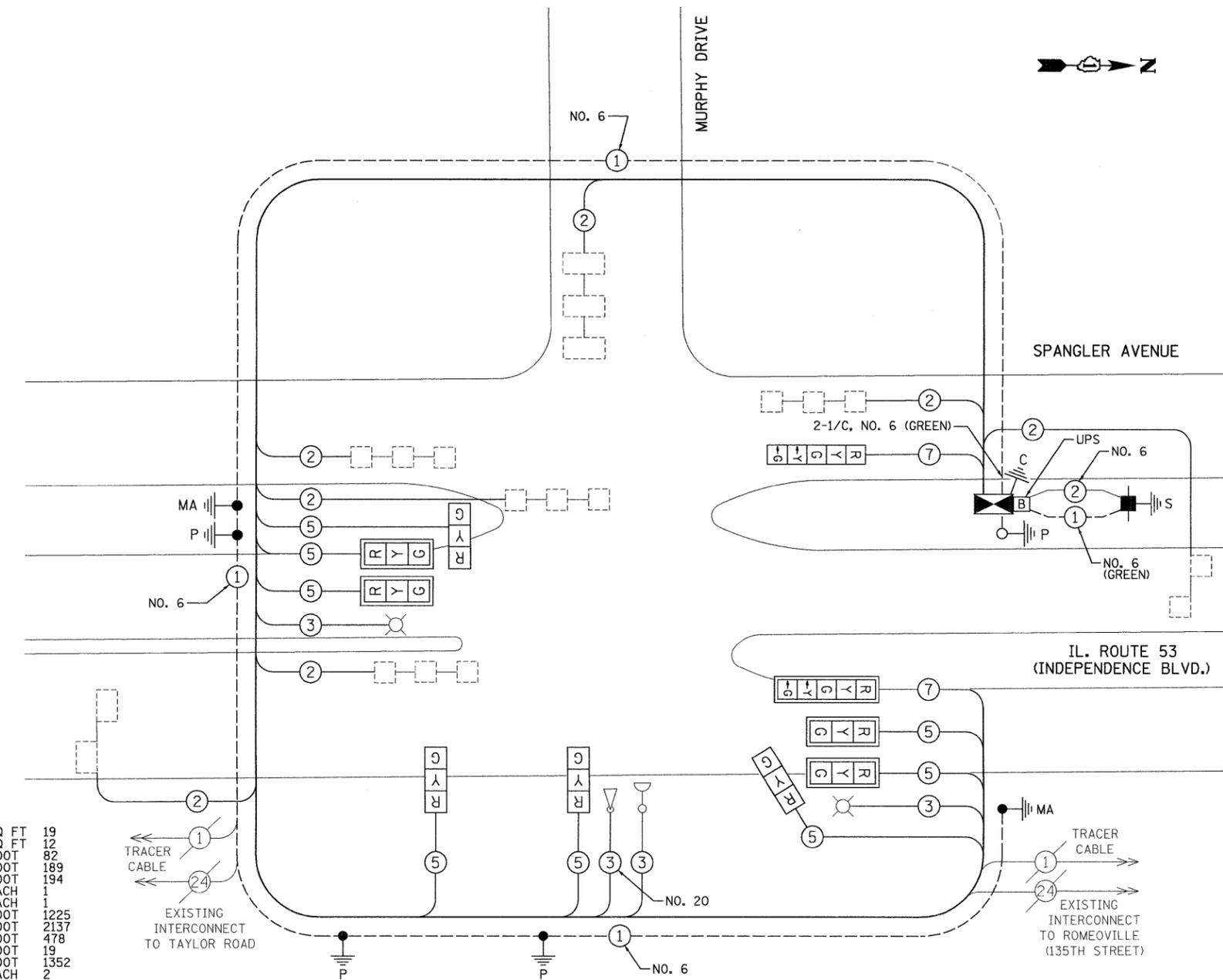

**CABLE PLAN**

**I.D.O.T TRAFFIC SIGNAL INSTALLATION ELECTRICAL SERVICE REQUIREMENTS**

TYPE	NO. LAMPS	WATTAGE INCAND.	LED	%OPERATION	TOTAL WATTAGE
SIGNAL (RED)	10	135	17	0.50	85
(YELLOW)	10	135	25	0.25	62.5
(GREEN)	10	135	15	0.25	37.5
ARROW	4	135	12	0.10	4.8
PED. SIGNAL		90	25	1.00	
CONTROLLER	1	100	100	1.00	100
ILLUM. SIGN		84		0.05	
FLASHER				0.50	

ENERGY COSTS TO:  
VILLAGE OF ROMEOVILLE  
13 MONTROSE DRIVE  
ROMEOVILLE, IL 60446

ENERGY SUPPLY CONTACT:  
PHONE:  
COMPANY:

FILE NAME =	USER NAME = RDS
MICROST\352072\ RT53 @MURPHY CAB.DGN	
PLOT SCALE = 1"=20'	
PLOT DATE = 03-18-09	

DESIGNED - KK	REVISED -
DRAWN - RDS	REVISED -
CHECKED - BPT	REVISED -
DATE - 03-18-09	REVISED -

**STATE OF ILLINOIS DEPARTMENT OF TRANSPORTATION**

**SCHEDULE OF QUANTITIES, CABLE PLAN AND PHASE DESIGNATION DIAGRAM**  
**IL. ROUTE 53 (INDEPENDENCE BLVD.) AT MURPHY DRIVE**

SCALE: N.T.S.	SHEET NO. OF SHEETS	STA. TO STA.
---------------	---------------------	--------------

PREPARED BY:  
**CEMCON, Ltd.**  
Consulting Engineers, Land Surveyors & Planners  
2280 White Oak Circle, Suite 100  
Aurora, Illinois 60504-9675  
Ph: 630.862.2100 Fax: 630.862.2199  
E-Mail: cadd@cemcon.com Website: www.cemcon.com

F.A.P. RTE.	SECTION	COUNTY	TOTAL SHEETS	SHEET NO.
	2009-039 TS	WILL	20	14
CONTRACT NO. 60G44				
FED. ROAD DIST. NO. ILLINOIS FED. AID PROJECT				

**TRAFFIC SIGNAL LEGEND**

PROPOSED	EXISTING	PROPOSED	EXISTING
CONTROLLER		PEDESTRIAN PUSH-BUTTON DETECTOR	
SERVICE INSTALLATION		DETECTOR LOOP, TYPE I	
SIGNAL HEAD		CAST IRON JUNCTION BOX	
SIGNAL HEAD WITH BACKPLATE		EMERGENCY VEHICLE SYSTEM DETECTOR	
SIGNAL HEAD, PEDESTRIAN		CONFIRMATION BEACON	
SIGNAL POST		SIGNAL HEAD OPTICALLY PROGRAMMED	
STEEL MAST ARM ASSEMBLY AND POLE		CONDUIT SPLICE	
MAST ARM ASSEMBLY AND POLE, ALUMINUM		WOOD POLE	
STEEL COMBINATION MAST ARM ASSEMBLY AND POLE WITH LUMINAIRE		RACEWAY FOR MAGNETIC DETECTOR, TYPE I OR TYPE II	
UNIT DUCT		VEHICLE DETECTOR, NON COMPENSATED MAGNETIC TYPE	
COMMON TRENCH		RAILROAD CONTROL CABINET	
HANDHOLE		TELEPHONE CONNECTION	
HEAVY DUTY HANDHOLE		ILLUMINATED SIGN "NO LEFT TURN"	
DOUBLE HANDHOLE		ILLUMINATED SIGN "NO RIGHT TURN"	
G.S. CONDUIT IN TRENCH (T) OR PUSHED (P)		UNINTERRUPTIBLE POWER SUPPLY	

**SIGN "A"**



**SIGN "B"**



(HORIZONTAL FOLDING SIGN WITH "DRIVE CAREFULLY" MESSAGE ON BACK WHEN FOLDED)

**DETAIL "A"**

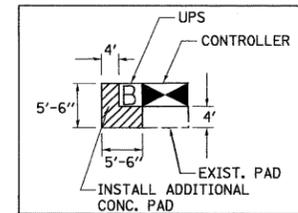

NOTE: THE WORK SHOWN IN DETAIL "A" SHALL BE INCLUDED IN THE COST FOR THE U.P.S. EQUIPMENT.

**DETAIL "B"**

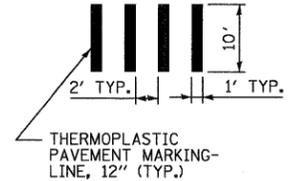

- 1) 5" THICK CONCRETE PAD SHALL BE POURED NEXT TO NEW CONTROLLER AND /OR UPS TO PROVIDE EASY MAINTENANCE ACCESS.
- 2) MAINTENANCE PAD SHALL EXTEND TO THE EDGE OF EXISTING CONTROLLER FOUNDATION.
- 3) COST OF PAD SHALL BE INCLUDED IN THE PRICE OF THE UNINTERRUPTIBLE POWER SUPPLY PAY ITEM.

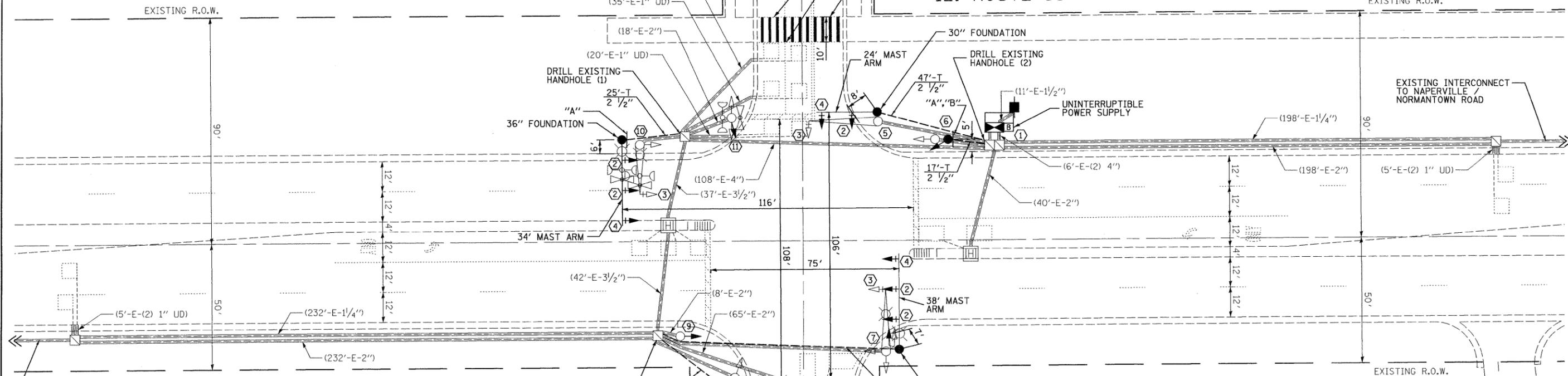

**REMOVAL AND INSTALLATION NOTES:**

- 1) REMOVE EXISTING CONTROLLER AND CABINET. INSTALL NEW FULL-ACTUATED CONTROLLER AND TYPE IV CABINET ON EXISTING FOUNDATION. INSTALL 4 FT CONCRETE MAINTENANCE PAD (SEE DETAIL "A" THIS SHEET). INSTALL UPS.
- 2) INSTALL NEW SIGNAL HEAD, LED, 1-FACE 3-SECTION, MAST ARM MOUNTED.
- 3) REMOVE EXISTING SIGNAL HEAD, 1-FACE 5-SECTION, MAST ARM MOUNTED.
- 4) INSTALL NEW SIGNAL HEAD, LED, 1-FACE 5-SECTION, MAST ARM MOUNTED.
- 5) REMOVE EXISTING MAST ARM ASSEMBLY AND POLE. REMOVE EXISTING CONCRETE FOUNDATION. INSTALL NEW STEEL MAST ARM ASSEMBLY AND POLE, 24 FT ON NEW FOUNDATION AT PROPOSED LOCATION AS SHOWN IN PLAN.
- 6) REMOVE EXISTING SIGNAL HEAD, 1-FACE 5-SECTION, BRACKET MOUNTED. REMOVE EXISTING TRAFFIC SIGNAL POST. REMOVE EXISTING CONCRETE FOUNDATION. INSTALL NEW TRAFFIC SIGNAL POST, 16 FT ON NEW FOUNDATION AT PROPOSED LOCATION AS SHOWN IN PLAN. INSTALL NEW SIGNAL HEAD, LED, 1-FACE 5-SECTION, BRACKET MOUNTED.
- 7) REMOVE AND REINSTALL EXISTING LUMINAIRE ON NEW COMBINATION POLE. REMOVE EXISTING SIGNAL HEAD, 3-FACE 3-SECTION, BRACKET MOUNTED. REMOVE EXISTING COMBINATION POLE. REMOVE EXISTING CONCRETE FOUNDATION. INSTALL NEW STEEL COMBINATION MAST ARM ASSEMBLY AND POLE, 38 FT ON NEW FOUNDATION AT PROPOSED LOCATION AS SHOWN IN PLAN.
- 8) REMOVE EXISTING TRAFFIC SIGNAL POST. REMOVE EXISTING CONCRETE FOUNDATION.
- 9) REMOVE EXISTING SIGNAL HEAD, 1-FACE 5-SECTION, BRACKET MOUNTED. INSTALL NEW SIGNAL HEAD, LED, 1-FACE 5-SECTION, BRACKET MOUNTED.
- 10) REMOVE AND REINSTALL EXISTING LUMINAIRE ON NEW COMBINATION POLE. REMOVE AND REINSTALL EXISTING EMERGENCY VEHICLE PREEMPTION LIGHT DETECTOR AND CONFIRMATION BEACON. REMOVE EXISTING SIGNAL HEAD, 1-FACE 3-SECTION, BRACKET MOUNTED. REMOVE EXISTING COMBINATION POLE. REMOVE EXISTING CONCRETE FOUNDATION. INSTALL NEW STEEL COMBINATION MAST ARM ASSEMBLY AND POLE, 34 FT ON NEW FOUNDATION AT PROPOSED LOCATION AS SHOWN IN PLAN.
- 11) REMOVE EXISTING SIGNAL HEAD, 2-FACE, 1-3 SECTION, 1-5 SECTION BRACKET MOUNTED. INSTALL NEW SIGNAL HEAD, 1-FACE, 5-SECTION, BRACKET MOUNTED.

THE FOLLOWING ITEMS SHALL BE REMOVED BY THE CONTRACTOR AND SHALL BE DISPOSED OF BY THEM OUTSIDE THE RIGHT-OF-WAY AT THEIR EXPENSE. THE SALVAGE VALUE OF THE REMOVED EQUIPMENT SHALL BE REFLECTED IN THE CONTRACT BID PRICE.

- |   |      |   |
|---|------|---|
| 1 | EACH | CONTROLLER AND CABINET (COMPLETE)             |
| 2 | EACH | SIGNAL HEAD, 1-FACE, 3-SECTION                |
| 1 | EACH | SIGNAL HEAD, 3-FACE, 3-SECTION                |
| 1 | EACH | SIGNAL HEAD, 2-FACE, 1-3-SECTION, 1-5-SECTION |
| 5 | EACH | SIGNAL HEAD, 1-FACE, 5-SECTION                |
| 3 | EACH | TRAFFIC SIGNAL BACKPLATE                      |
| 2 | EACH | TRAFFIC SIGNAL POST                           |
| 2 | EACH | COMBINATION MAST ARM ASSEMBLY AND POLE        |
| 1 | EACH | MAST ARM ASSEMBLY AND POLE                    |
| 1 | EACH | SERVICE INSTALLATION                          |

NOTE: RELOCATE EXISTING MAST ARM MOUNTED SIGNS TO NEW MAST ARMS.

NOTE: THE TRAFFIC SIGNAL CONTROL EQUIPMENT FOR THIS PROJECT SHALL BE "ECONOLITE" TO MATCH THE EXISTING ADJACENT SYSTEM.

NOTE: CONTRACTOR SHALL REINSTALL "EVP" EQUIPMENT WHERE SHOWN TO NEW MAST ARM AND CONTROLLER. THIS WORK SHALL BE INCLUDED IN COST FOR "FULL-ACTUATED CONTROLLER AND TYPE IV CABINET, SPECIAL".

NOTE: THE CONTRACTOR SHALL BE REQUIRED TO MAINTAIN THE OPERATION OF THE TRAFFIC SIGNALS DURING THE ENTIRE PROJECT.

FILE NAME =	USER NAME = RDS	DESIGNED - KK	REVISED -
\\MICROST\352072\ IL53 @BELMONT SIG.DGN		DRAWN - RDS	REVISED -
	PLOT SCALE = 1"=20'	CHECKED - BPT	REVISED -
	PLOT DATE = 03-18-09	DATE - 03-18-09	REVISED -

**STATE OF ILLINOIS  
DEPARTMENT OF TRANSPORTATION**

**TRAFFIC SIGNAL MODIFICATION PLAN  
IL. ROUTE 53 (INDEPENDENCE BLVD.) AT BELMONT DRIVE**

SCALE: N.T.S. SHEET NO. OF SHEETS STA. TO STA.

PREPARED BY:  
**CEMCON, Ltd.**  
Consulting Engineers, Land Surveyors & Planners  
2280 White Oak Circle, Suite 100  
Aurora, Illinois 60504-9675  
Ph: 630.862.2100 Fax: 630.862.2199  
E-Mail: cadd@cemcon.com Website: www.cemcon.com

F.A.P. RTE.	SECTION	COUNTY	TOTAL SHEETS	SHEET NO.
	2009-039 TS	WILL	20	15
CONTRACT NO. 60G44				
FED. ROAD DIST. NO. ILLINOIS FED. AID PROJECT				

**CONTROLLER SEQUENCE**

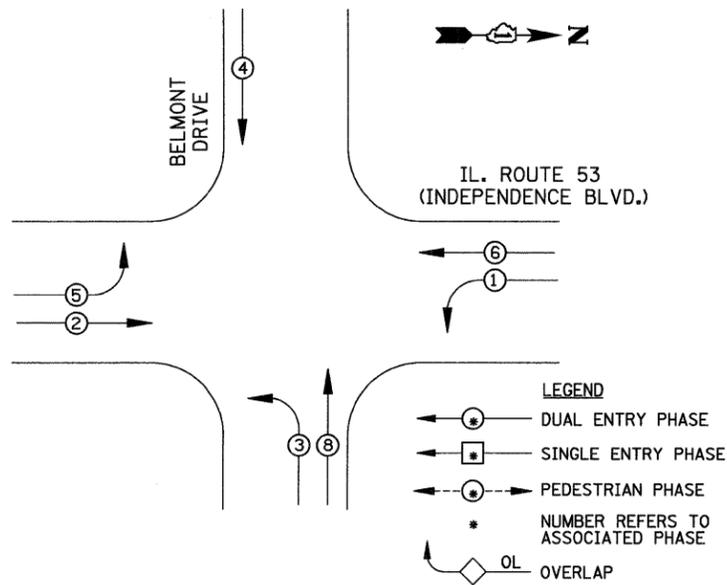

**PHASE DESIGNATION DIAGRAM**

**EMERGENCY VEHICLE PREEMPTION SEQUENCE**

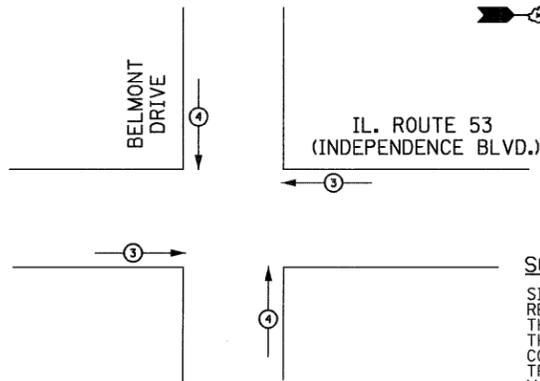

PROPOSED EMERGENCY VEHICLE PREEMPTOR			
EMERGENCY VEHICLE PREEMPTOR	3	4	
MOVEMENT	←	↑	

**CABLE PLAN LEGEND**

- EXISTING PROPOSED
- 8" (200mm) TRAFFIC SIGNAL SECTION
- 12" (300mm) TRAFFIC SIGNAL SECTION
- 12" (300mm) PEDESTRIAN SIGNAL SECTION
- 12" (300mm) PEDESTRIAN SIGNAL SECTION
- CONTROLLER CABINET
- SERVICE INSTALLATION
- TELEPHONE CONNECTION
- MAGNETIC DETECTOR
- EMERGENCY VEHICLE LIGHT DETECTOR
- CONFIRMATION BEACON
- PUSH-BUTTON DETECTOR
- VEHICLE DETECTOR, INDUCTION LOOP
- DENOTES NUMBER OF CONDUCTORS. ALL CABLE NO. 14 EXCEPT AS INDICATED. ALL LOOP DETECTOR CABLE TO BE SHIELDED.
- GROUND CABLE IN CONDUIT NO. 6 SOLID COPPER (GREEN)
- FIBER OPTIC CABLE IN CONDUIT NO. 62.5/125 2-MM12F SM12F
- SIGNAL FACE WITH BACKPLATE. "P" INDICATES PROGRAMMED HEAD
- RAILROAD CONTROL CABINET
- ILLUMINATED SIGN "NO LEFT TURN"
- ILLUMINATED SIGN "NO RIGHT TURN"
- GROUND ROD AT HANDHOLE (H), DOUBLE HANDHOLE (H), OR CONTROLLER (C)
- GROUND ROD AT POST (P), OR MAST ARM POLE (MA)
- GROUND ROD AT ELECTRIC SERVICE INSTALLATION
- UNINTERRUPTIBLE POWER SUPPLY

**SCHEDULE OF QUANTITIES**

SIGN PANEL, TYPE 1	SQ FT	12
RELOCATE SIGN PANEL, TYPE 1	SQ FT	19
THERMOPLASTIC PAVEMENT MARKING, LINE-12"	FOOT	115
THERMOPLASTIC PAVEMENT MARKING REMOVAL	SQ FT	34
CONDUIT IN TRENCH, 2 1/2" DIA., GALVANIZED STEEL	FOOT	222
TRENCH AND BACKFILL FOR ELECTRICAL WORK	FOOT	222
MAINTENANCE OF EXISTING TRAFFIC SIGNAL INSTALLATION	EACH	1
FULL-ACTUATED CONTROLLER AND TYPE IV CABINET, SPECIAL	EACH	1
ELECTRIC CABLE IN CONDUIT, SIGNAL NO. 14 3C	FOOT	931
ELECTRIC CABLE IN CONDUIT, SIGNAL NO. 14 5C	FOOT	2168
ELECTRIC CABLE IN CONDUIT, SIGNAL NO. 14 7C	FOOT	1198
ELECTRIC CABLE IN CONDUIT, SERVICE, NO. 6 2C	FOOT	12
ELECTRIC CABLE IN CONDUIT, LEAD-IN, NO. 14 1 PAIR	FOOT	1823
TRAFFIC SIGNAL POST, GALVANIZED STEEL 16 FT.	EACH	1
STEEL MAST ARM ASSEMBLY AND POLE, 24 FT.	EACH	2
STEEL COMBINATION MAST ARM ASSEMBLY AND POLE 34 FT.	EACH	1
STEEL COMBINATION MAST ARM ASSEMBLY AND POLE 38 FT.	EACH	1
CONCRETE FOUNDATION, TYPE A	FOOT	4
CONCRETE FOUNDATION, TYPE A 30-INCH DIAMETER	FOOT	30
CONCRETE FOUNDATION, TYPE E 36-INCH DIAMETER	FOOT	30
DRILL EXISTING HANDHOLE	EACH	3
SIGNAL HEAD, LED, 1-FACE, 3-SECTION, MAST-ARM MOUNTED	EACH	7
SIGNAL HEAD, LED, 1-FACE, 3-SECTION, BRACKET MOUNTED	EACH	1
SIGNAL HEAD, LED, 1-FACE, 5-SECTION, BRACKET MOUNTED	EACH	3
SIGNAL HEAD, LED, 1-FACE, 5-SECTION, MAST-ARM MOUNTED	EACH	3
TRAFFIC SIGNAL BACKPLATE, LOUVERED, ALUMINUM	EACH	10
REMOVE ELECTRIC CABLE FROM CONDUIT	FOOT	6109
REMOVE EXISTING TRAFFIC SIGNAL EQUIPMENT	EACH	1
REMOVE EXISTING CONCRETE FOUNDATION	EACH	5
SERVICE INSTALLATION, POLE MOUNT	EACH	1
RELOCATE EXISTING LUMINAIRE	EACH	2
ELECTRIC CABLE IN CONDUIT, GROUNDING, NO. 6 1C	FOOT	508
ELECTRIC CABLE IN CONDUIT, NO. 20 3/C, TWISTED & SHIELDED	FOOT	357
UNINTERRUPTIBLE POWER SUPPLY	EACH	1
REBUILD EXISTING HANDHOLE	EACH	1

NOTE:  
THE TRAFFIC SIGNAL CONTROL EQUIPMENT FOR THIS PROJECT SHALL BE "ECONOLITE" TO MATCH THE EXISTING ADJACENT SYSTEM.

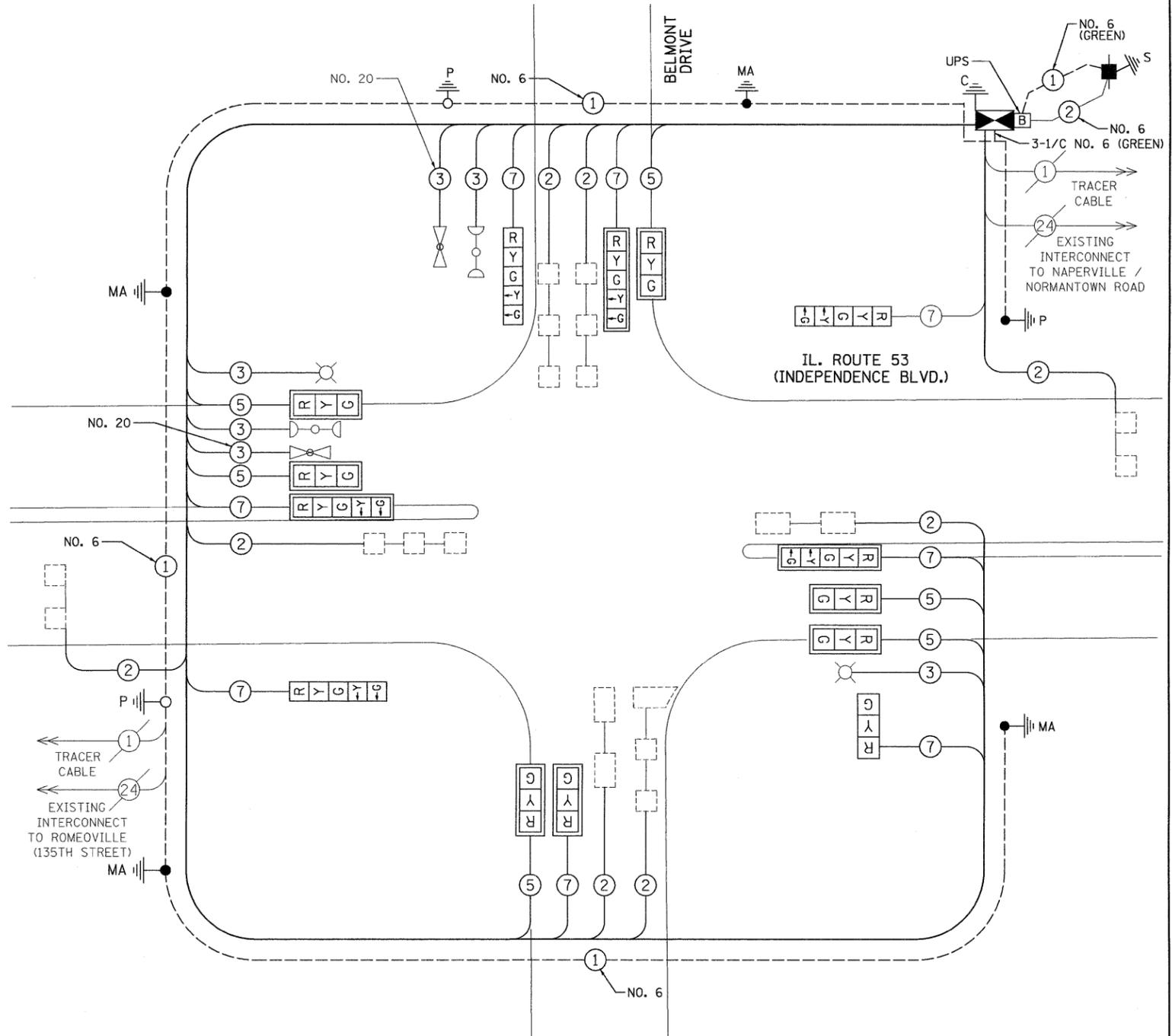

**CABLE PLAN**

I.D.O.T TRAFFIC SIGNAL INSTALLATION ELECTRICAL SERVICE REQUIREMENTS						TOTAL WATTAGE
TYPE	NO. LAMPS	WATTAGE INCAND.	LED	%OPERATION		
SIGNAL (RED)	14	135	17	0.50		119
(YELLOW)	14	135	25	0.25		87.5
(GREEN)	14	135	15	0.25		52.5
ARROW	12	135	12	0.10		14.4
PED. SIGNAL	90	25		1.00		
CONTROLLER	1	100	100	1.00		100
ILLUM. SIGN		84		0.05		
FLASHER				0.50		
TOTAL =						373.4

ENERGY COSTS TO:  
VILLAGE OF ROMEOVILLE  
13 MONTROSE DRIVE  
ROMEOVILLE, IL 60446

ENERGY SUPPLY CONTACT:  
PHONE:  
COMPANY:

FOUNDATION (DEPTH)	FT. (m)	CABLE SLACK	FT. (m)	VERTICAL	FT. (m)
TYPE A - POST	4 (1.2)	HANDHOLE	6.5 (2.0)	ALL FOUNDATIONS	3.0 (1.0)
D - CONTROLLER	4 (1.2)	DOUBLE HANDHOLE	13 (4.0)	MAST ARM (L) POLE	20.0 (6.0)
E - M. ARM POLE		SIGNAL POST	0 (0.0)	BRACKET MOUNTED	13 (4.0)
24" (600mm)	10 (3.0)	CONTROLLER CAB.	0 (0.0)	PED. PUSH-BUTTON	6 (2.0)
30" (750mm)	15 (4.6)	FIBER OPTIC	13 (4.0)	ELECTRIC SERVICE	13.5 (4.1)
		ELECTRIC SERVICE	1 (0.5)	SERVICE TO GROUND	13.5 (4.1)
		GROUND CABLE	1 (0.5)	POST MOUNTED	13 (4.0)

**STATE OF ILLINOIS  
DEPARTMENT OF TRANSPORTATION**

**SCHEDULE OF QUANTITIES, CABLE PLAN  
AND PHASE DESIGNATION DIAGRAM  
IL. ROUTE 53 (INDEPENDENCE BLVD.) AT BELMONT DRIVE**

SCALE: N.T.S. SHEET NO. OF SHEETS STA. TO STA.

PREPARED BY:  
**CEMCON, Ltd.**  
Consulting Engineers, Land Surveyors & Planners  
2280 White Oak Circle, Suite 100  
Aurora, Illinois 60504-9675  
Ph: 630.862.2100 Fax: 630.862.2199  
E-Mail: cadd@cemcon.com Website: www.cemcon.com

F.A.P. RTE.	SECTION	COUNTY	TOTAL SHEETS	SHEET NO.
	2009-039 TS	WILL	20	16
CONTRACT NO. 60G44				
FED. ROAD DIST. NO. ILLINOIS FED. AID PROJECT				

FILE NAME = \MICROST\362072\ RT53 @BELMNT CAB.DGN  
USER NAME = RDS  
DESIGNED - KK  
DRAWN - RDS  
CHECKED - BPT  
PLOT SCALE = 1"=20'  
PLOT DATE = 03-18-09  
DATE - 03-18-09

CONTROLLER  
SERVICE INSTALLATION  
SIGNAL HEAD  
SIGNAL HEAD WITH BACKPLATE  
SIGNAL HEAD, PEDESTRIAN WITH COUNTDOWN TIMER  
SIGNAL POST  
STEEL MAST ARM ASSEMBLY AND POLE  
MAST ARM ASSEMBLY AND POLE, ALUMINUM  
STEEL COMBINATION MAST ARM ASSEMBLY AND POLE WITH LUMINAIRE  
UNIT DUCT  
COMMON TRENCH  
HANDHOLE  
HEAVY DUTY HANDHOLE  
DOUBLE HANDHOLE  
G.S. CONDUIT IN TRENCH (T) OR PUSHED (P)

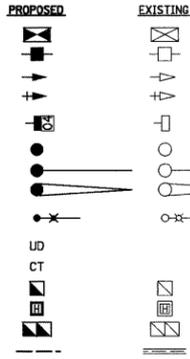

PEDESTRIAN PUSH-BUTTON DETECTOR  
DETECTOR LOOP, TYPE I  
CAST IRON JUNCTION BOX  
EMERGENCY VEHICLE SYSTEM DETECTOR  
CONFIRMATION BEACON  
SIGNAL HEAD OPTICALLY PROGRAMMED  
CONDUIT SPLICE  
WOOD POLE  
RAILWAY FOR MAGNETIC DETECTOR, TYPE I OR TYPE II  
VEHICLE DETECTOR, NON COMPENSATED MAGNETIC TYPE  
RAILROAD CONTROL CABINET  
TELEPHONE CONNECTION  
ILLUMINATED SIGN "NO LEFT TURN"  
ILLUMINATED SIGN "NO RIGHT TURN"  
UNINTERRUPTIBLE POWER SUPPLY

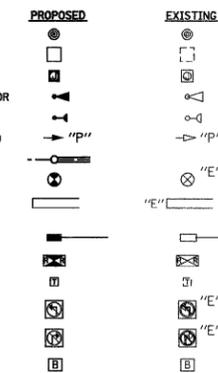

**SIGN "A"**



**SIGN ASSEMBLY "B"**

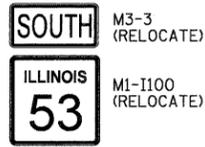

**SIGN "E"**



**SIGN "C"**



**SIGN "D"**

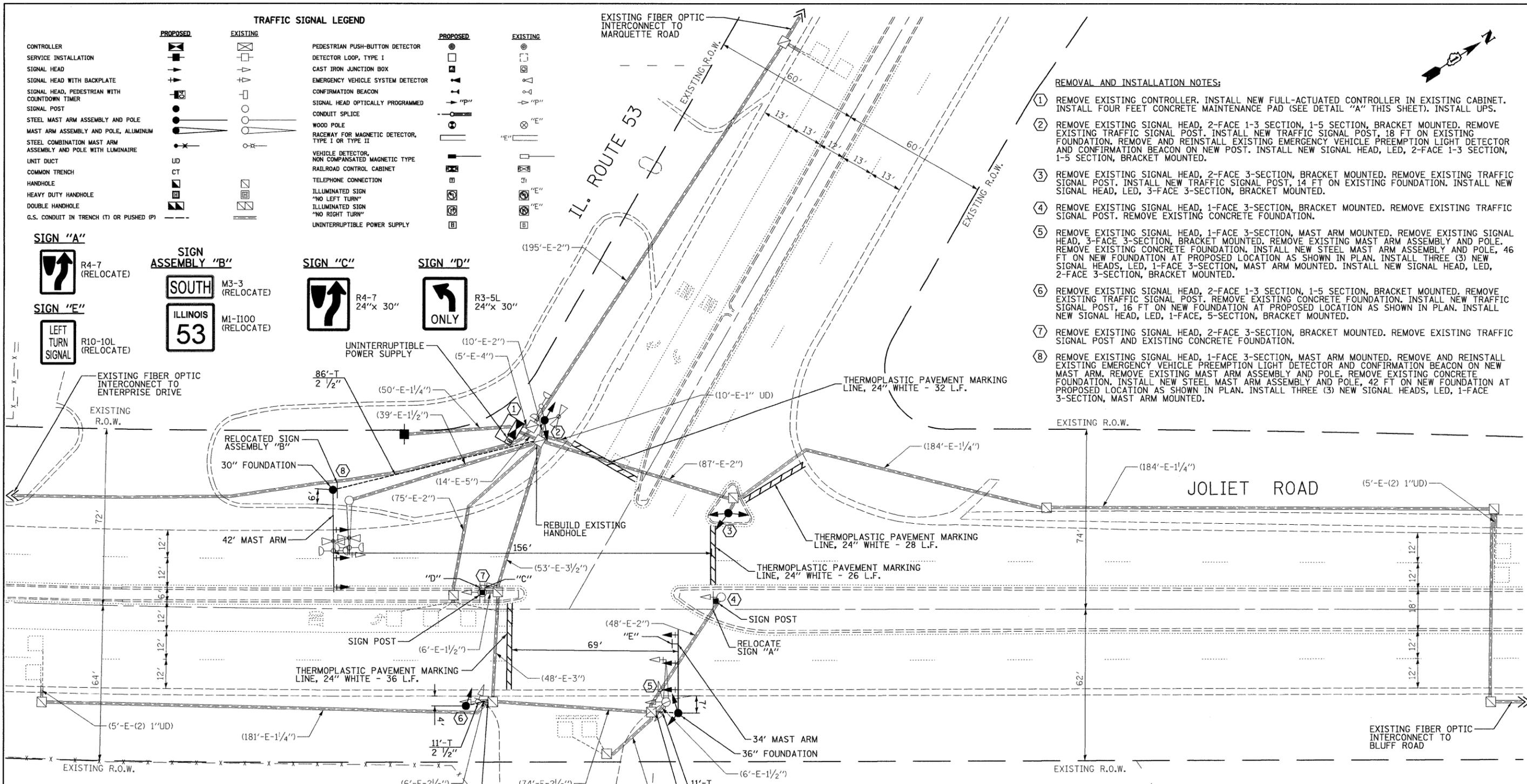

- REMOVAL AND INSTALLATION NOTES:**
- 1) REMOVE EXISTING CONTROLLER. INSTALL NEW FULL-ACTUATED CONTROLLER IN EXISTING CABINET. INSTALL FOUR FEET CONCRETE MAINTENANCE PAD (SEE DETAIL "A" THIS SHEET). INSTALL UPS.
  - 2) REMOVE EXISTING SIGNAL HEAD, 2-FACE 1-3 SECTION, 1-5 SECTION, BRACKET MOUNTED. REMOVE EXISTING TRAFFIC SIGNAL POST. INSTALL NEW TRAFFIC SIGNAL POST, 18 FT ON EXISTING FOUNDATION. REMOVE AND REINSTALL EXISTING EMERGENCY VEHICLE PREEMPTION LIGHT DETECTOR AND CONFIRMATION BEACON ON NEW POST. INSTALL NEW SIGNAL HEAD, LED, 2-FACE 1-3 SECTION, BRACKET MOUNTED.
  - 3) REMOVE EXISTING SIGNAL HEAD, 2-FACE 3-SECTION, BRACKET MOUNTED. REMOVE EXISTING TRAFFIC SIGNAL POST. INSTALL NEW TRAFFIC SIGNAL POST, 14 FT ON EXISTING FOUNDATION. INSTALL NEW SIGNAL HEAD, LED, 3-FACE 3-SECTION, BRACKET MOUNTED.
  - 4) REMOVE EXISTING SIGNAL HEAD, 1-FACE 3-SECTION, BRACKET MOUNTED. REMOVE EXISTING TRAFFIC SIGNAL POST. REMOVE EXISTING CONCRETE FOUNDATION.
  - 5) REMOVE EXISTING SIGNAL HEAD, 1-FACE 3-SECTION, MAST ARM MOUNTED. REMOVE EXISTING SIGNAL HEAD, 3-FACE 3-SECTION, BRACKET MOUNTED. REMOVE EXISTING MAST ARM ASSEMBLY AND POLE. REMOVE EXISTING CONCRETE FOUNDATION. INSTALL NEW STEEL MAST ARM ASSEMBLY AND POLE, 46 FT ON NEW FOUNDATION AT PROPOSED LOCATION AS SHOWN IN PLAN. INSTALL THREE (3) NEW SIGNAL HEADS, LED, 1-FACE 3-SECTION, MAST ARM MOUNTED. INSTALL NEW SIGNAL HEAD, LED, 2-FACE 3-SECTION, BRACKET MOUNTED.
  - 6) REMOVE EXISTING SIGNAL HEAD, 2-FACE 1-3 SECTION, 1-5 SECTION, BRACKET MOUNTED. REMOVE EXISTING TRAFFIC SIGNAL POST. REMOVE EXISTING CONCRETE FOUNDATION. INSTALL NEW TRAFFIC SIGNAL POST, 16 FT ON NEW FOUNDATION AT PROPOSED LOCATION AS SHOWN IN PLAN. INSTALL NEW SIGNAL HEAD, LED, 1-FACE, 5-SECTION, BRACKET MOUNTED.
  - 7) REMOVE EXISTING SIGNAL HEAD, 2-FACE 3-SECTION, BRACKET MOUNTED. REMOVE EXISTING TRAFFIC SIGNAL POST AND EXISTING CONCRETE FOUNDATION.
  - 8) REMOVE EXISTING SIGNAL HEAD, 1-FACE 3-SECTION, MAST ARM MOUNTED. REMOVE AND REINSTALL EXISTING EMERGENCY VEHICLE PREEMPTION LIGHT DETECTOR AND CONFIRMATION BEACON ON NEW MAST ARM. REMOVE EXISTING MAST ARM ASSEMBLY AND POLE. REMOVE EXISTING CONCRETE FOUNDATION. INSTALL NEW STEEL MAST ARM ASSEMBLY AND POLE, 42 FT ON NEW FOUNDATION AT PROPOSED LOCATION AS SHOWN IN PLAN. INSTALL THREE (3) NEW SIGNAL HEADS, LED, 1-FACE 3-SECTION, MAST ARM MOUNTED.

**DETAIL "A"**

N.T.S.

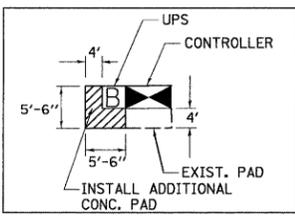

- 1) 5" THICK CONCRETE PAD SHALL BE POURED NEXT TO NEW CONTROLLER AND /OR UPS TO PROVIDE EASY MAINTENANCE ACCESS.
- 2) MAINTENANCE PAD SHALL EXTEND TO THE EDGE OF EXISTING CONTROLLER FOUNDATION.
- 3) COST OF PAD SHALL BE INCLUDED IN THE PRICE OF THE UNINTERRUPTIBLE POWER SUPPLY PAY ITEM.

**NOTE:**  
THE WORK SHOWN IN DETAIL "A" SHALL BE INCLUDED IN THE COST FOR THE U.P.S. EQUIPMENT.

**NOTE:**  
THE CONTRACTOR SHALL BE REQUIRED TO MAINTAIN THE OPERATION OF THE TRAFFIC SIGNALS DURING THE ENTIRE PROJECT.

**NOTE:**  
RELOCATE SIGNS ON MAST ARMS AND SIGNAL POSTS TO NEW MAST ARMS.

**NOTE:**  
CONTRACTOR SHALL REINSTALL "EVP" EQUIPMENT WHERE SHOWN TO NEW MAST ARM OR TRAFFIC SIGNAL POST AND CABINET. THIS WORK SHALL BE INCLUDED IN COST FOR "FULL-ACTUATED CONTROLLER IN EXISTING CABINET, SPECIAL".

**NOTE:**  
THE TRAFFIC SIGNAL CONTROL EQUIPMENT FOR THIS PROJECT SHALL BE "ECONOLITE" TO MATCH THE EXISTING ADJACENT SYSTEM.

THE FOLLOWING ITEMS SHALL BE REMOVED BY THE CONTRACTOR AND SHALL BE DISPOSED OF BY THEM OUTSIDE THE RIGHT-OF-WAY AT THEIR EXPENSE. THE SALVAGE VALUE OF THE REMOVED EQUIPMENT SHALL BE REFLECTED IN THE CONTRACT BID PRICE.

- 1 EACH CONTROLLER
- 3 EACH SIGNAL HEAD, 1-FACE, 3-SECTION
- 2 EACH SIGNAL HEAD, 2-FACE, 3-SECTION
- 2 EACH SIGNAL HEAD, 2-FACE, 1-3-SECTION, 1-5-SECTION
- 1 EACH SIGNAL HEAD, 3-FACE, 3-SECTION
- 1 EACH TRAFFIC SIGNAL BACKPLATE
- 2 EACH TRAFFIC SIGNAL POST
- 1 EACH MAST ARM ASSEMBLY AND POLE
- 1 EACH SERVICE INSTALLATION

FILE NAME =	USER NAME = RDS	DESIGNED - KK	REVISED -
\\MICROST\352072\ RT53 @JOLIET SIG.DGN		DRAWN - RDS	REVISED -
	PLOT SCALE = 1"=20'	CHECKED - BPT	REVISED -
	PLOT DATE = 03-18-09	DATE - 03-18-09	REVISED -

**STATE OF ILLINOIS  
DEPARTMENT OF TRANSPORTATION**

**TRAFFIC SIGNAL MODIFICATION PLAN  
IL. ROUTE 53 AT JOLIET ROAD**

SCALE: N.T.S. SHEET NO. OF SHEETS STA. TO STA.

PREPARED BY:  
**CEMCON, Ltd.**  
Consulting Engineers, Land Surveyors & Planners  
2280 White Oak Circle, Suite 100  
Aurora, Illinois 60504-9675  
Ph: 630.862.2100 Fax: 630.862.2199  
E-Mail: codd@cemcon.com Website: www.cemcon.com

F.A.P. RTE.	SECTION	COUNTY	TOTAL SHEETS	SHEET NO.
	2009-039 TS	WILL	20	17
FED. ROAD DIST. NO.			ILLINOIS FED. AID PROJECT	
			CONTRACT NO. 60G44	

**CONTROLLER SEQUENCE**

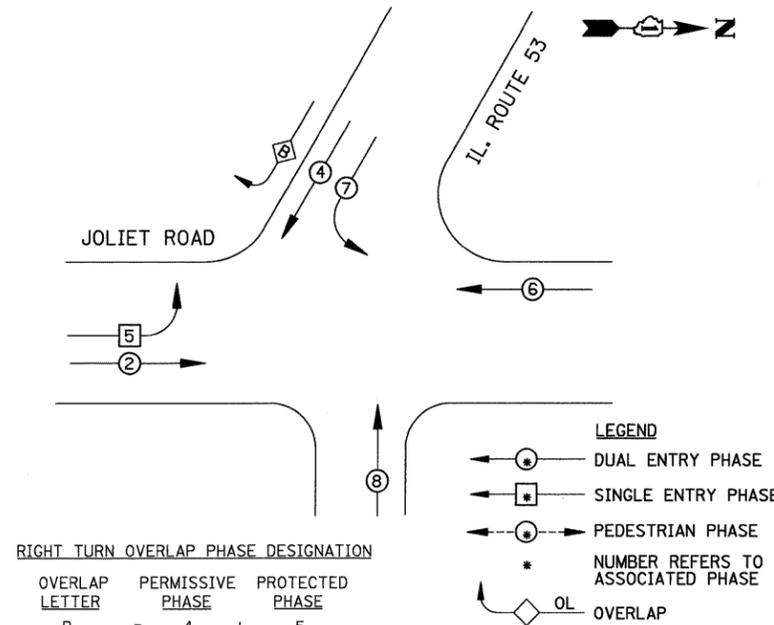

**PHASE DESIGNATION DIAGRAM**

**EMERGENCY VEHICLE PREEMPTION SEQUENCE**

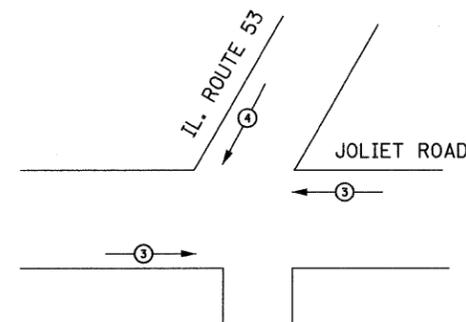

**PROPOSED EMERGENCY VEHICLE PREEMPTOR**

EMERGENCY VEHICLE PREEMPTOR	3	4
MOVEMENT	← →	↑ ↓

**CABLE PLAN LEGEND**

- EXISTING**
- PROPOSED**
- 8" (200mm) TRAFFIC SIGNAL SECTION
- 12" (300mm) TRAFFIC SIGNAL SECTION
- 12" (300mm) PEDESTRIAN SIGNAL SECTION
- 12" (300mm) PEDESTRIAN SIGNAL SECTION
- CONTROLLER CABINET
- SERVICE INSTALLATION
- TELEPHONE CONNECTION
- MAGNETIC DETECTOR
- EMERGENCY VEHICLE LIGHT DETECTOR
- CONFIRMATION BEACON
- PUSH-BUTTON DETECTOR
- VEHICLE DETECTOR, INDUCTION LOOP
- 2 DENOTES NUMBER OF CONDUCTORS, ALL CABLE NO. 14 EXCEPT AS INDICATED. ALL LOOP DETECTOR CABLE TO BE SHIELDED.
- 1 GROUND CABLE IN CONDUIT NO. 6 SOLID COPPER (GREEN)
- 24 FIBER OPTIC CABLE IN CONDUIT NO. 62.5/125 2-MM12F SM12F
- SIGNAL FACE WITH BACKPLATE, "P" INDICATES PROGRAMMED HEAD
- RAILROAD CONTROL CABINET
- ILLUMINATED SIGN "NO LEFT TURN"
- ILLUMINATED SIGN "NO RIGHT TURN"
- GROUND ROD AT HANDHOLE (H), DOUBLE HANDHOLE (H), OR CONTROLLER (C)
- GROUND ROD AT POST (P), OR MAST ARM POLE (MA)
- GROUND ROD AT ELECTRIC SERVICE INSTALLATION
- UNINTERRUPTIBLE POWER SUPPLY

**SCHEDULE OF QUANTITIES**

SIGN PANEL, TYPE 1	24	SQ FT
RELOCATE SIGN PANEL, TYPE 1	16	SQ FT
TELESCOPING STEEL SIGN SUPPORT	30	FOOT
THERMOPLASTIC PAVEMENT MARKING, LINE-24"	121	FOOT
THERMOPLASTIC PAVEMENT MARKING REMOVAL	121	SQ FT
CONDUIT IN TRENCH, 2 1/2" DIA., GALVANIZED STEEL	108	FOOT
TRENCH AND BACKFILL FOR ELECTRICAL WORK	108	FOOT
MAINTENANCE OF EXISTING TRAFFIC SIGNAL INSTALLATION	1	EACH
FULL-ACTUATED CONTROLLER IN EXISTING CABINET, SPECIAL	1	EACH
ELECTRIC CABLE IN CONDUIT, SIGNAL NO. 14 3C	191	FOOT
ELECTRIC CABLE IN CONDUIT, SIGNAL NO. 14 5C	2326	FOOT
ELECTRIC CABLE IN CONDUIT, SIGNAL NO. 14 7C	216	FOOT
ELECTRIC CABLE IN CONDUIT, SERVICE, NO. 6 2C	51	FOOT
ELECTRIC CABLE IN CONDUIT, LEAD-IN, NO. 14 1 PAIR	909	FOOT
TRAFFIC SIGNAL POST, GALVANIZED STEEL 14 FT.	1	EACH
TRAFFIC SIGNAL POST, GALVANIZED STEEL 16 FT.	1	EACH
TRAFFIC SIGNAL POST, GALVANIZED STEEL 18 FT.	1	EACH
STEEL MAST ARM ASSEMBLY AND POLE, 42 FT.	1	EACH
STEEL MAST ARM ASSEMBLY AND POLE, 46 FT.	1	EACH
STEEL COMBINATION MAST ARM ASSEMBLY AND POLE 22 FT.	1	EACH
CONCRETE FOUNDATION, TYPE A	4	FOOT
CONCRETE FOUNDATION, TYPE E 36-INCH DIAMETER	30	FOOT
DRILL EXISTING HANDHOLE	2	EACH
SIGNAL HEAD, LED, 1-FACE, 3-SECTION, MAST-ARM MOUNTED	6	EACH
SIGNAL HEAD, LED, 1-FACE, 5-SECTION, BRACKET MOUNTED	1	EACH
SIGNAL HEAD, LED, 2-FACE, 3-SECTION, BRACKET MOUNTED	1	EACH
SIGNAL HEAD, LED, 2-FACE, 1-3 SECTION, 1-5 SECTION, BRACKET MOUNTED	1	EACH
SIGNAL HEAD, LED, 3-FACE, 3-SECTION, BRACKET MOUNTED	1	EACH
TRAFFIC SIGNAL BACKPLATE, LOUVERED, ALUMINUM	6	EACH
REMOVE ELECTRIC CABLE FROM CONDUIT	3730	FOOT
REMOVE EXISTING TRAFFIC SIGNAL EQUIPMENT	1	EACH
REMOVE EXISTING CONCRETE FOUNDATION	5	EACH
SERVICE INSTALLATION, POLE MOUNT	1	EACH
ELECTRIC CABLE IN CONDUIT, GROUNDING, NO. 6 1C	666	FOOT
ELECTRIC CABLE IN CONDUIT, NO. 20 3/C, TWISTED & SHIELDED	191	FOOT
UNINTERRUPTIBLE POWER SUPPLY	1	EACH
REBUILD EXISTING HANDHOLE	1	EACH

FOUNDATION (DEPTH)	FT. (m)	CABLE SLACK	FT. (m)	VERTICAL	FT. (m)
TYPE A - POST	4 (1.2)	HANDHOLE	6.5 (2.0)	ALL FOUNDATIONS	3.0 (1.0)
D - CONTROLLER	4 (1.2)	DOUBLE HANDHOLE	13 (4.0)	MAST ARM (L) POLE	20.0 (6.0)
E - M. ARM POLE		SIGNAL POST	0 (0.0)	BRACKET MOUNTED	13 (4.0)
24" (600mm)	10 (3.0)	CONTROLLER CAB.	0 (0.0)	PED. PUSH-BUTTON	6 (2.0)
30" (750mm)	15 (4.6)	FIBER OPTIC	13 (4.0)	ELECTRIC SERVICE	13.5 (4.1)
		ELECTRIC SERVICE	1 (0.5)	SERVICE TO GROUND	13.5 (4.1)
		GROUND CABLE	1 (0.5)	POST MOUNTED	13 (4.0)

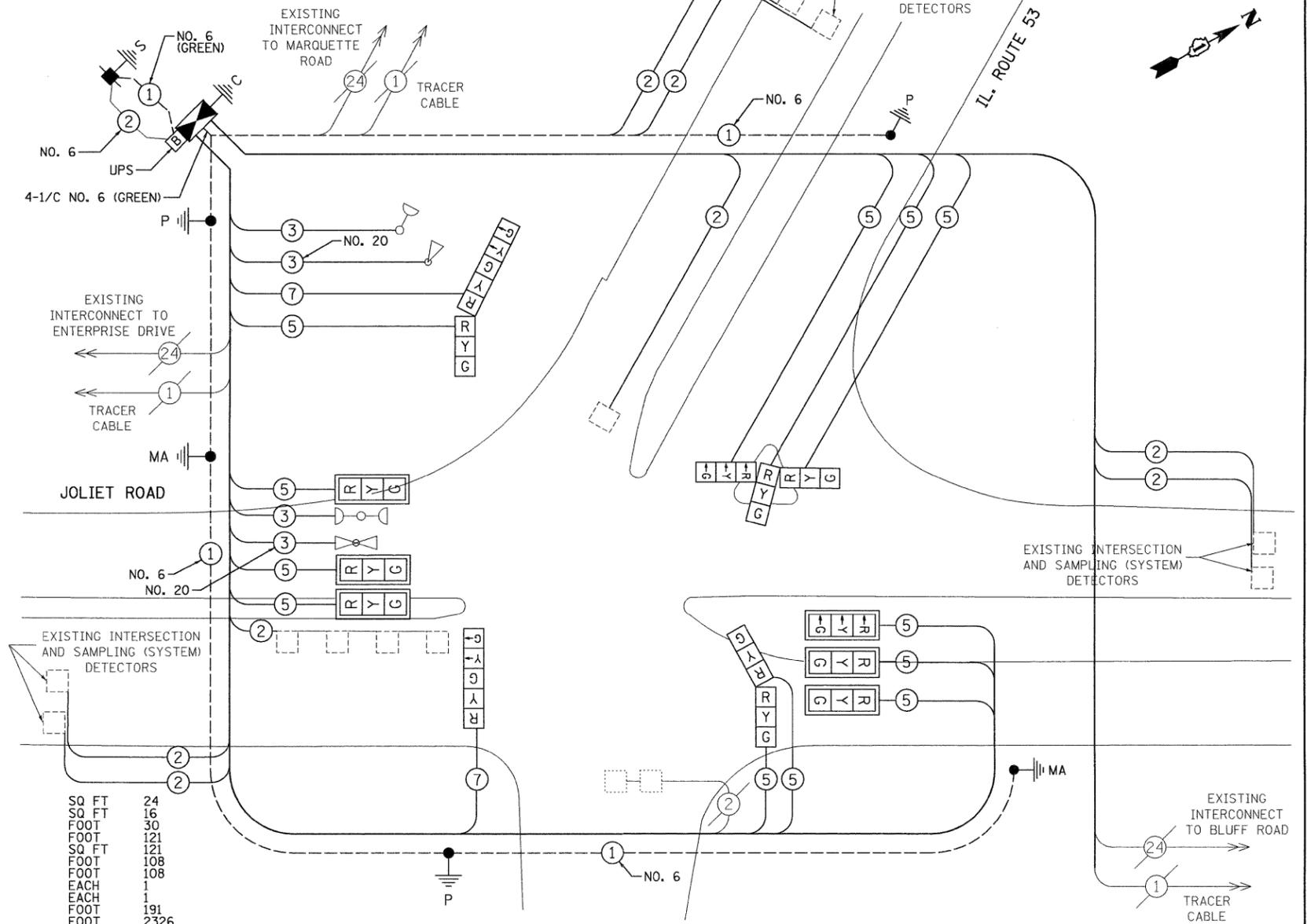

**CABLE PLAN**

I.D.O.T TRAFFIC SIGNAL INSTALLATION ELECTRICAL SERVICE REQUIREMENTS					TOTAL WATTAGE
TYPE	NO. LAMPS	WATTAGE		%OPERATION	
SIGNAL (RED)	13	135	17	0.50	110.5
		135	25	0.25	68.75
	(YELLOW)	11	135	15	0.25
(GREEN)	8	135	12	0.10	9.6
ARROW		90	25	1.00	
PED. SIGNAL	1	100	100	1.00	100
CONTROLLER					
ILLUM. SIGN		84		0.05	

FLASHER				0.50	
ENERGY COSTS TO:					TOTAL =
VILLAGE OF ROMEOVILLE					230.1
13 MONTROSE DRIVE					
ROMEOVILLE, IL 60446					

ENERGY SUPPLY CONTACT:	
PHONE:	
COMPANY:	

FILE NAME =	USER NAME = RDS	DESIGNED - KK	REVISED -
\\MICROSTV352072\RT53 @JOLIET CAB.DGN		DRAWN - RDS	REVISED -
	PLOT SCALE = 1"=20'	CHECKED - BPT	REVISED -
	PLOT DATE = 03-18-09	DATE - 03-18-09	REVISED -

**STATE OF ILLINOIS DEPARTMENT OF TRANSPORTATION**

**SCHEDULE OF QUANTITIES, CABLE PLAN AND PHASE DESIGNATION DIAGRAM IL. ROUTE 53 AT JOLIET ROAD**

SCALE: N.T.S. SHEET NO. OF SHEETS STA. TO STA.

PREPARED BY:  
**CEMCON, Ltd.**  
 Consulting Engineers, Land Surveyors & Planners  
 2280 White Oak Circle, Suite 100  
 Aurora, Illinois 60504-9675  
 Ph: 630.862.2100 Fax: 630.862.2199  
 E-Mail: cadd@cemcon.com Website: www.cemcon.com

F.A.P. RTE.	SECTION	COUNTY	TOTAL SHEETS	SHEET NO.
	2009-039 TS	WILL	20	18
CONTRACT NO. 60G44				
FED. ROAD DIST. NO. [ILLINOIS] FED. AID PROJECT				

# FOR INFORMATION ONLY

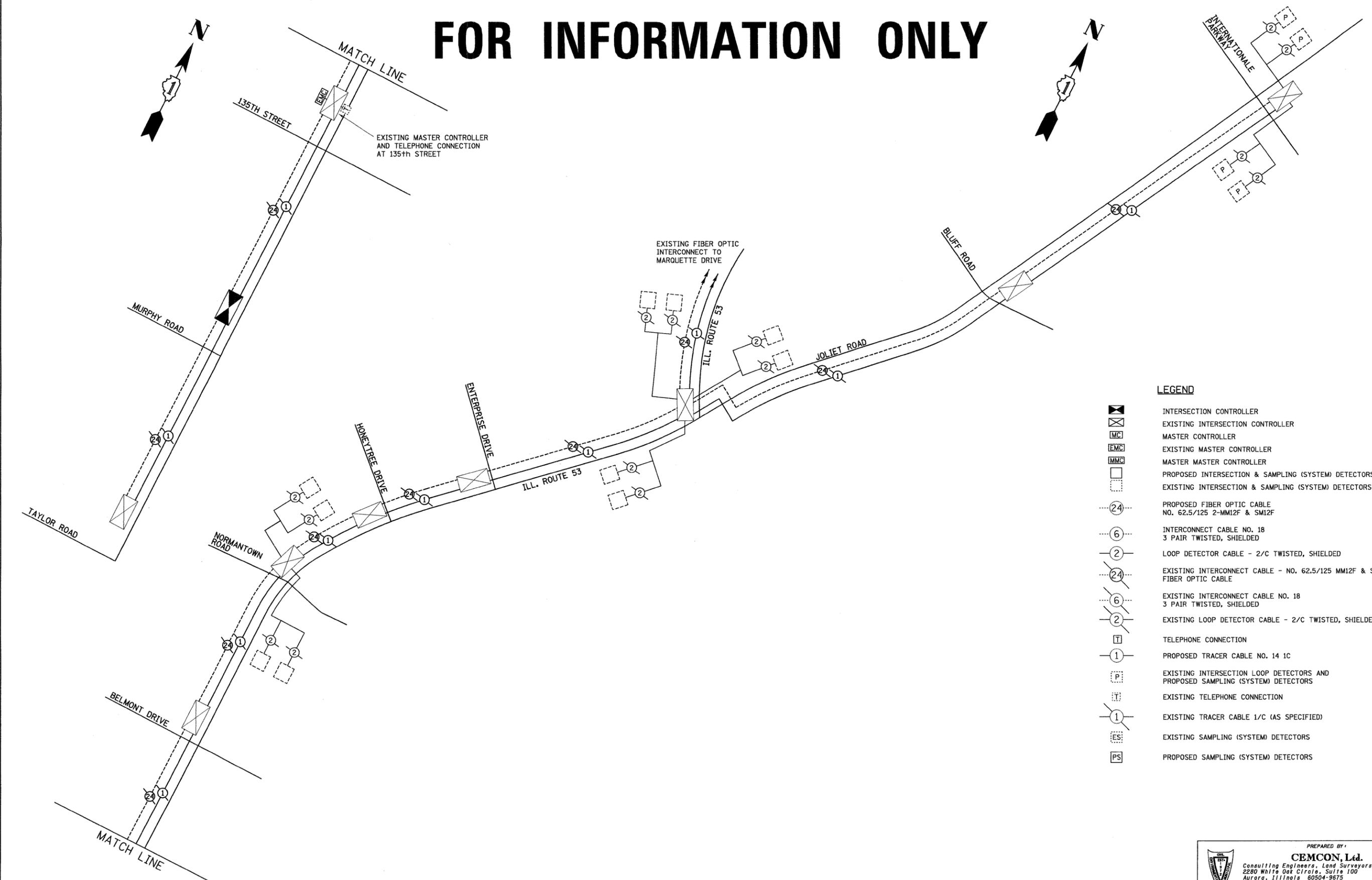

## LEGEND

- INTERSECTION CONTROLLER
- EXISTING INTERSECTION CONTROLLER
- MASTER CONTROLLER
- EXISTING MASTER CONTROLLER
- MASTER MASTER CONTROLLER
- PROPOSED INTERSECTION & SAMPLING (SYSTEM) DETECTORS
- EXISTING INTERSECTION & SAMPLING (SYSTEM) DETECTORS
- PROPOSED FIBER OPTIC CABLE  
NO. 62.5/125 2-MM12F & SM12F
- INTERCONNECT CABLE NO. 18  
3 PAIR TWISTED, SHIELDED
- LOOP DETECTOR CABLE - 2/C TWISTED, SHIELDED
- EXISTING INTERCONNECT CABLE - NO. 62.5/125 MM12F & SM12F  
FIBER OPTIC CABLE
- EXISTING INTERCONNECT CABLE NO. 18  
3 PAIR TWISTED, SHIELDED
- EXISTING LOOP DETECTOR CABLE - 2/C TWISTED, SHIELDED
- TELEPHONE CONNECTION
- PROPOSED TRACER CABLE NO. 14 1C
- EXISTING INTERSECTION LOOP DETECTORS AND  
PROPOSED SAMPLING (SYSTEM) DETECTORS
- EXISTING TELEPHONE CONNECTION
- EXISTING TRACER CABLE 1/C (AS SPECIFIED)
- EXISTING SAMPLING (SYSTEM) DETECTORS
- PROPOSED SAMPLING (SYSTEM) DETECTORS

PREPARED BY:  
**CEMCON, Ltd.**  
 Consulting Engineers, Land Surveyors & Planners  
 2280 White Oak Circle, Suite 100  
 Aurora, Illinois 60504-9675  
 Ph: 630.862.2100 Fax: 630.862.2199  
 E-Mail: ccd@cemcon.com Website: www.cemcon.com

FILE NAME = MICROST\352072\19-INT SCHEMATIC.DGN	USER NAME = RDS	DESIGNED - KK	REVISED -
		DRAWN - RDS	REVISED -
		CHECKED - BPT	REVISED -
		DATE - 03-18-09	REVISED -

**STATE OF ILLINOIS**  
**DEPARTMENT OF TRANSPORTATION**

**INTERCONNECT SCHEMATIC**  
**IL. ROUTE 53 FROM TAYLOR ROAD TO INTERNATIONALE PARKWAY**

SCALE: N.T.S.    SHEET NO.    OF    SHEETS    STA.    TO STA.

F.A.P. RTE.	SECTION	COUNTY	TOTAL SHEETS	SHEET NO.
	2009-039 TS	WILL	20	19
CONTRACT NO. 60G44				
FED. ROAD DIST. NO.    ILLINOIS    FED. AID PROJECT				

PANEL SIGN DESIGN TYPE 1

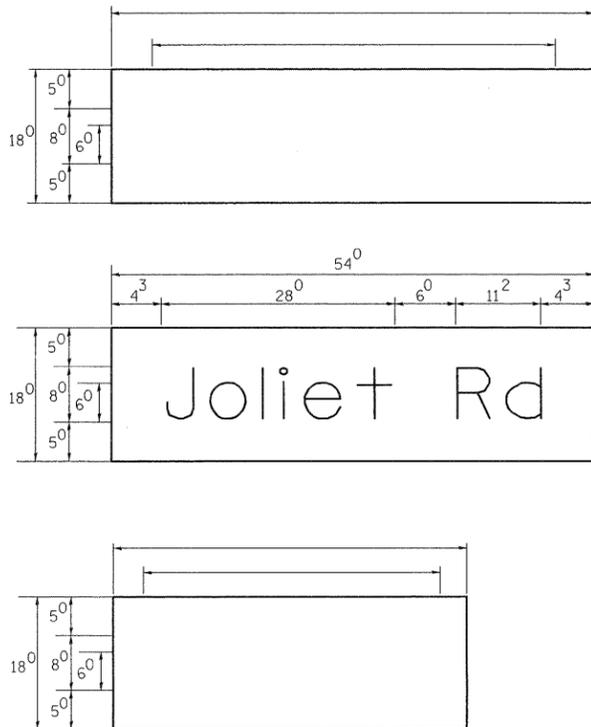

Sq. M. each  
 Sq. Ft. each  
 Required  
 Design Series

Sq. M. each  
 6.8 Sq. Ft. each  
 2 Required  
 Design Series D

Sq. M. each  
 Sq. Ft. each  
 Required  
 Design Series

NOTE: SIGN DIMENSIONS ARE IN ENGLISH UNITS

PANEL SIGN DESIGN TYPE 2

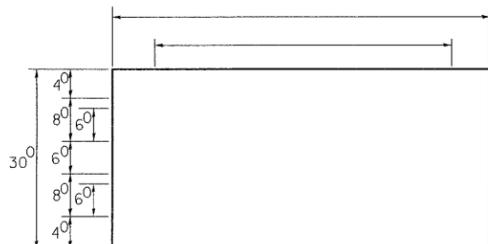

Sq. M. each  
 Sq. Ft. each  
 Required  
 Design Series

GENERAL NOTES

- WHERE MAST ARM MOUNTED STREET NAME SIGNS ARE SPECIFIED, THE MAST ARM ASSEMBLY AND POLES SHALL BE DESIGNED TO SUPPORT THE LOADINGS CALLED FOR ON STANDARDS 834001, 834006 AND 834011, AS APPLICABLE, PLUS TWO (2) SIGN PANELS 2'-6" X 6'-0" MOUNTED AS SHOWN. THE DESIGN SHALL BE IN ACCORDANCE WITH THE REQUIREMENTS OF THE CURRENT "STANDARD SPECIFICATIONS FOR STRUCTURAL SUPPORTS FOR HIGHWAY SIGNS, LUMINAIRES, AND TRAFFIC SIGNALS" AS PUBLISHED BY THE AMERICAN ASSOCIATION OF STATE HIGHWAY AND TRANSPORTATION OFFICIALS FOR 80 M.P.H. WIND VELOCITY.
- ALL SIGNS SHALL HAVE A WHITE REFLECTORIZED LEGEND AND BORDER ON A GREEN REFLECTORIZED BACKGROUND, TYPE A SHEETING.
- THE SIGN LENGTH SHOULD BE INCREASED IN 6-INCH INCREMENTS, BUT THE OVERALL LENGTH SHOULD NOT EXCEED 6'-0".
- ALL BORDERS SHALL BE 3/4" WIDE AND CORNER RADIUS SHALL BE 2-1/4".
- SIGNFIX ALUMINUM CHANNEL FRAMING SYSTEM SHALL BE USED FOR ALL SIGNS ATTACHED TO SIGNAL POLES AND POSTS. LOCAL SUPPLIERS OF THE SIGNFIX ALUMINUM CHANNEL FRAMING SYSTEM ARE:
  - \* A.K.T. CORPORATION SCHAUMBURG, IL
  - \* TUCKER COMPANY, INC. WAUWATOSA, WI
  - \* AMERICAN FABRICATION CO. CHICAGO HEIGHTS, IL
  - \* WESTERN TRAFFIC CONTROL INC. CICERO, IL

PARTS LISTING:  
 SIGN CHANNEL PART #HPN053 (MED. CHANNEL)  
 SIGN SCREWS 1/4" x 14 x 1" H.W.H. #3  
 SELF TAPPING WITH NEOPRENE WASHER  
 BRACKETS PART #HPN034 (UNIVERSAL)  
 CHANNEL CLAMPS WITH STAINLESS STEEL STRAPPING

OTHER BRANDS OF MOUNTING HARDWARE ARE ACCEPTABLE, BASED UPON THE DEPARTMENT'S APPROVAL AND COMPATIBILITY WITH THE CHANNEL/BACKET OF THE ABOVE PRODUCT.

SUPPORTING CHANNELS

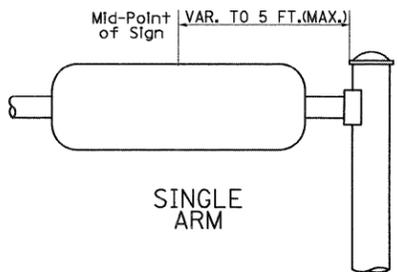
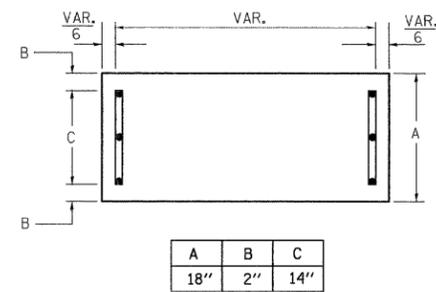

SUPPORTING CHANNELS

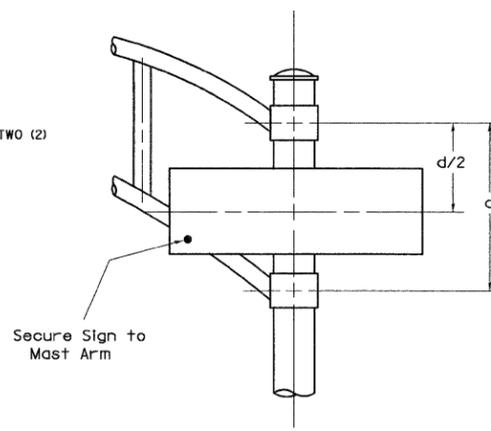
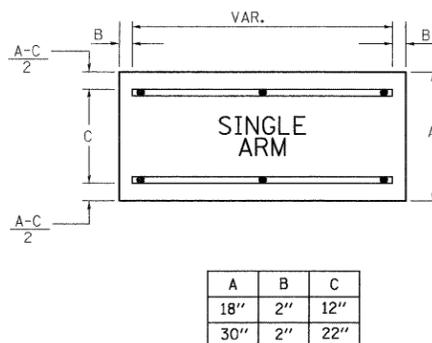

**DUAL ARM**  
 SIGNFIX ALUMINUM CHANNEL FRAMING SYSTEM  
 Shall be used. See Note #5.

Upper Case To Lower Case

Spacing Chart 8-6 Inch Series "C & D"

EXAMPLE, 2<sup>3</sup> DENOTES 3/8"

UPPER AND LOWER CASE LETTER WIDTHS

SERIES	SECOND LETTER																										
	a	c	d	e	g	o	q	b	h	i	k	l	m	n	p	r	u	f	w	J	s	t	v	y	x	Z	
A W X	12	14	14	15	12	14	06	10	11	14	06	10	11	12	12	14	14	15	12	14	15	12	14	14	15	14	15
B	14	15	20	21	14	15	11	12	14	15	12	14	12	14	16	17											
C E G	14	15	20	21	12	14	06	10	12	14	12	14	14	15	14	15											
D O Q R	14	15	20	21	14	15	06	10	12	14	12	14	14	15	14	15											
F	05	06	14	15	06	10	05	06	06	10	06	10	06	10	11	12											
H I M N	20	21	22	24	20	21	14	15	16	17	16	17	20	21	20	21											
J U	20	21	20	21	16	17	14	15	16	17	16	17	16	17	20	21											
K L	11	12	16	17	11	12	05	06	11	12	11	12	11	12	12	14											
P	12	14	14	15	12	14	05	06	11	12	11	12	12	14	12	14											
S	12	14	16	17	12	14	06	10	12	14	12	14	12	14	12	14											
T	11	12	16	17	06	10	06	10	11	12	11	12	11	12	12	14											
V	06	10	14	15	11	12	06	10	12	14	12	14	12	14	12	14											
Y	05	06	14	15	06	10	05	06	05	07	05	06	06	10	11	12											
Z	16	17	22	24	16	17	12	14	16	17	16	17	16	17	20	21											

Lower Case To Lower Case

Spacing Chart 6 Inch Series "C & D"

SERIES	SECOND LETTER																										
	a	c	d	e	g	o	q	b	h	i	k	l	m	n	p	r	u	f	w	J	s	t	v	y	x	Z	
ad h g l j	16	17	22	24	16	17	12	14	14	15	14	15	16	17	16	17											
lm n q u																											
b f k o p s	12	14	16	17	11	12	05	06	11	12	11	12	12	14	12	14											
c e	12	14	16	17	12	14	06	10	12	14	12	14	12	14	12	14											
r	06	10	12	14	06	10	03	03	05	06	05	06	06	10	06	10											
t z	12	14	16	17	12	14	06	10	11	12	11	12	12	14	12	14											
v y	11	12	14	15	11	12	05	06	06	10	06	10	11	12	11	12											
w	11	12	14	15	11	12	05	06	11	12	11	12	11	12	12	14											
x	12	14	16	17	11	12	05	06	11	12	11	12	11	12	12	14											

Number To Number

Spacing Chart 8 Inch Series "C & D"

SERIES	SECOND NUMBER																			
	0	1	2	3	4	5	6	7	8	9	C	D	C	D	C	D	C	D		
0 9	16	17	16	17	14	15	12	14	14	15	14	15	16	17	12	14	16	17	16	17
1	20	21	20	21	20	21	16	17	14	15	20	21	20	21	14	15	20	21	20	21
2 3 4	14	15	14	15	14	15	12	14	12	14	14	15	14	15	11	12	16	17	14	15
5	14	15	14	15	14	15	11	12	11	12	14	15	14	15	11	12	14	15	14	15
6	16	17	14	15	14	15	12	14	14	15	14	15	11	12	14	15	14	15	14	15
7	12	14	12	14	14	15	12	15	05	06	12	14	14	15	11	12	14	15	12	14
8	16	17	16	17	14	15	12	15	12	14	14	15	16	17	12	14	16	17	14	15

LETTERS	6 INCH UPPER CASE LETTERS		8 INCH UPPER CASE LETTERS		LETTERS	6 INCH LOWER CASE LETTERS	
	C	D	C	D		C	D
A	3 <sup>6</sup>	5 <sup>0</sup>	5 <sup>0</sup>	6 <sup>5</sup>	a	3 <sup>5</sup>	4 <sup>2</sup>
B	3 <sup>2</sup>	4 <sup>0</sup>	4 <sup>3</sup>	5 <sup>3</sup>	b	3 <sup>5</sup>	4 <sup>2</sup>
C	3 <sup>2</sup>	4 <sup>0</sup>	4 <sup>3</sup>	5 <sup>3</sup>	c	3 <sup>5</sup>	4 <sup>1</sup>
D	3 <sup>2</sup>	4 <sup>0</sup>	4 <sup>3</sup>	5 <sup>3</sup>	d	3 <sup>5</sup>	4 <sup>2</sup>
E	3 <sup>0</sup>	3 <sup>5</sup>	4 <sup>0</sup>	4 <sup>7</sup>	e	3 <sup>5</sup>	4 <sup>2</sup>
F	3 <sup>0</sup>	3 <sup>5</sup>	4 <sup>0</sup>	4 <sup>7</sup>	f	2 <sup>3</sup>	2 <sup>6</sup>
G	3 <sup>2</sup>	4 <sup>0</sup>	4 <sup>3</sup>	5 <sup>3</sup>	g	3 <sup>5</sup>	4 <sup>2</sup>
H	3 <sup>2</sup>	4 <sup>0</sup>	4 <sup>3</sup>	5 <sup>3</sup>	h	3 <sup>5</sup>	4 <sup>2</sup>
I	0 <sup>7</sup>	0 <sup>7</sup>	1 <sup>1</sup>	1 <sup>2</sup>	i	1 <sup>1</sup>	1 <sup>1</sup>
J	3 <sup>0</sup>	3 <sup>6</sup>	4 <sup>0</sup>	5 <sup>0</sup>	j	2 <sup>0</sup>	2 <sup>2</sup>
K	3 <sup>2</sup>	4 <sup>1</sup>	4 <sup>3</sup>	5 <sup>4</sup>	k	3 <sup>5</sup>	4 <sup>2</sup>
L	3 <sup>0</sup>	3 <sup>5</sup>	4 <sup>0</sup>	4 <sup>7</sup>	l	1 <sup>1</sup>	1 <sup>1</sup>
M	3 <sup>7</sup>	4 <sup>5</sup>	5 <sup>1</sup>	6 <sup>1</sup>	m	6 <sup>0</sup>	7 <sup>0</sup>
N	3 <sup>2</sup>	4 <sup>0</sup>	4 <sup>3</sup>	5 <sup>3</sup>	n	3 <sup>5</sup>	4 <sup>2</sup>
O	3 <sup>4</sup>	4 <sup>2</sup>	4 <sup>5</sup>	5 <sup>5</sup>	o	3 <sup>6</sup>	4 <sup>3</sup>
P	3 <sup>2</sup>	4 <sup>0</sup>	4 <sup>3</sup>	5 <sup>3</sup>	p	3 <sup>5</sup>	4 <sup>2</sup>
Q	3 <sup>4</sup>	4 <sup>2</sup>	4 <sup>5</sup>	5 <sup>5</sup>	q	3 <sup>5</sup>	4 <sup>2</sup>
R	3 <sup>2</sup>	4 <sup>0</sup>	4 <sup>3</sup>	5 <sup>3</sup>	r	2 <sup>6</sup>	3 <sup>2</sup>
S	3 <sup>2</sup>	4 <sup>0</sup>	4 <sup>3</sup>	5 <sup>3</sup>	s	3 <sup>6</sup>	4 <sup>2</sup>
T	3 <sup>0</sup>	3 <sup>5</sup>	4 <sup>0</sup>	4 <sup>7</sup>	t	2 <sup>7</sup>	3 <sup>2</sup>
U	3 <sup>2</sup>	4 <sup>0</sup>	4 <sup>3</sup>	5 <sup>3</sup>	u	3 <sup>5</sup>	4 <sup>2</sup>
V	3 <sup>5</sup>	4 <sup>4</sup>	4 <sup>7</sup>	6 <sup>0</sup>	v	4 <sup>2</sup>	4 <sup>7</sup>
W	4 <sup>4</sup>	5 <sup>2</sup>	6 <sup>0</sup>	7 <sup>0</sup>	w	5 <sup>5</sup>	6 <sup>4</sup>
X	3 <sup>4</sup>	4 <sup>0</sup>	4 <sup>5</sup>	5 <sup>3</sup>	x	4 <sup>4</sup>	5 <sup>1</sup>
Y	3 <sup>6</sup>	5 <sup>0</sup>	5 <sup>0</sup>	6 <sup>6</sup>	y	4 <sup>6</sup>	5 <sup>3</sup>
Z	3 <sup>2</sup>	4 <sup>0</sup>	4 <sup>3</sup>	5 <sup>3</sup>	z	3 <sup>6</sup>	4 <sup>3</sup>

NUMBER	6 INCH SERIES		8 INCH SERIES	
	C	D	C	D
1	12	14	15	20
2	3 <sup>2</sup>	4 <sup>0</sup>	4 <sup>3</sup>	5 <sup>3</sup>
3	3 <sup>2</sup>	4 <sup>0</sup>	4 <sup>3</sup>	5 <sup>3</sup>
4	3 <sup>5</sup>	4 <sup>3</sup>	4 <sup>7</sup>	5 <sup>7</sup>
5	3 <sup>2</sup>	4 <sup>0</sup>	4 <sup>3</sup>	5 <sup>3</sup>
6	3 <sup>2</sup>	4 <sup>0</sup>	4 <sup>3</sup>	5 <sup>3</sup>
7	3 <sup>2</sup>	4 <sup>0</sup>	4 <sup>3</sup>	5 <sup>3</sup>
8	3 <sup>2</sup>	4 <sup>0</sup>	4 <sup>3</sup>	5 <sup>3</sup>
9	3 <sup>2</sup>	4 <sup>0</sup>	4 <sup>3</sup>	5 <sup>3</sup>
0	3 <sup>4</sup>	4 <sup>2</sup>	4 <sup>5</sup>	5 <sup>5</sup>

PREPARED BY:  
**CEMCON, Ltd.**  
 Consulting Engineers, Land Surveyors & Planners  
 2280 White Oak Circle, Suite 100  
 Aurora, Illinois 60504-9675  
 Ph: 630.862.2100 Fax: 630.862.2199  
 E-Mail: [cad@cemcon.com](mailto:cad@cemcon.com) [Website: www.cemcon.com](http://www.cemcon.com)

FILE NAME =	USER NAME = RDS	DESIGNED - KK	REVISED -	STATE OF ILLINOIS	MAST ARM MOUNTED STREET NAME SIGN	F.A.P. R.T.E.	SECTION	COUNTY	TOTAL SHEETS	SHEET NO.
\MICROST\352072\ ST NAME JOLIET.DGN		DRAWN - RDS	REVISED -	DEPARTMENT OF TRANSPORTATION	IL ROUTE 53 AT JOLIET ROAD		2009-039 TS	WILL	20	20
	PLOT SCALE = 1"=20'	CHECKED - BPT	REVISED -							
	PLOT DATE = 03-18-09	DATE - 03-18-09	REVISED -		SCALE: N.T.S. SHEET NO. OF SHEETS STA. TO STA.					CONTRACT NO. 60G44
							FED. ROAD DIST. NO.	ILLINOIS	FED. AID PROJECT	