

F.A. RTE.	SECTION	COUNTY	TOTAL SHEETS	SHEET NO.
361	06-00214-25-BR	KANE	220	1
FED. ROAD DIST. NO. 1		ILLINOIS	CONTRACT NO. 63076	

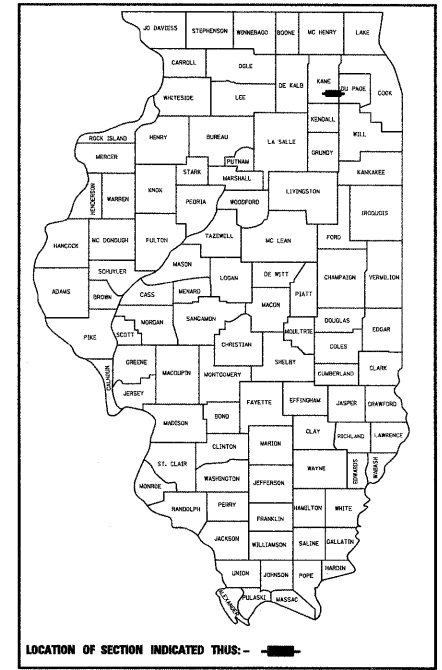

STATE OF ILLINOIS
COUNTY OF KANE
DIVISION OF TRANSPORTATION

PROPOSED HIGHWAY PLANS

F.A.P. 361 (STEARNS ROAD)
STAGE 5
RANDALL ROAD TO McLEAN BOULEVARD
SECTION 06-00214-25-BR
PROJECT NO. HPP-1527 (018)
C-91-247-06

IMPROVEMENT LOCATED IN THE VILLAGE OF SOUTH ELGIN.

INDEX OF SHEETS
FOR INDEX OF SHEETS, SEE SHEET NO. 2

FOR LIST OF STATE STANDARDS, SEE SHEET NO.3

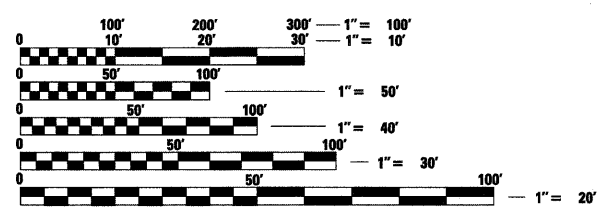

FULL SIZE PLANS HAVE BEEN PREPARED USING STANDARD ENGINEERING SCALES. REDUCED SIZED PLANS WILL NOT CONFORM TO STANDARD SCALES. IN MAKING MEASUREMENTS ON REDUCED PLANS, THE ABOVE SCALES MAY BE USED.

Call Before You Dig
JULIE
800.892.0123
Joint Utility Locating Information for Excavators
Call 48 hours before you dig (Excluding Sat., Sun. & Holidays)

J.U.L.I.E.
JOINT UTILITY LOCATION INFORMATION FOR EXCAVATION
1-800-892-0123 OR 811

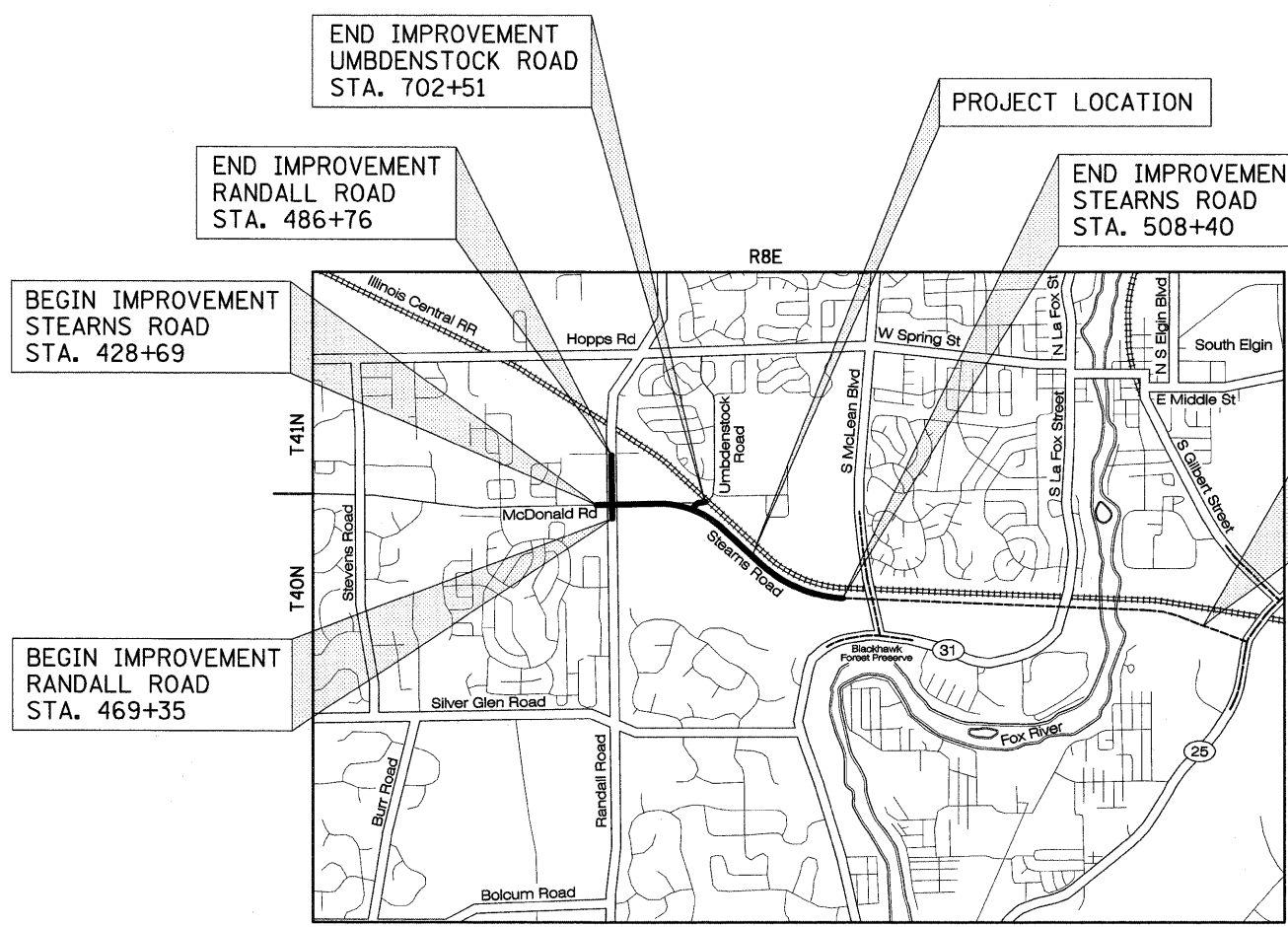

LOCATION MAP
NOT TO SCALE

PROJECT LENGTH:
STEARNS ROAD - 7971 FT (1.51 MILE) (NET & GROSS)
UMBDENSTOCK ROAD - 251 FT (0.05 MILE) (NET & GROSS)
RANDALL ROAD - 1741 FT (0.33 MILE) (NET & GROSS)
PROJECT TOTAL - 9963 FT (1.89 MILE) (NET & GROSS)

POSTED AND DESIGN SPEEDS:
STEARNS ROAD - 45 MPH DESIGN; 45 MPH POSTED
UMBDENSTOCK ROAD - 30 MPH DESIGN; 30 MPH POSTED
RANDALL ROAD - 50 MPH DESIGN; 50 MPH POSTED

STATE OF ILLINOIS
DEPARTMENT OF TRANSPORTATION
DIVISION OF HIGHWAYS

APPROVED MARCH 27 2009
DIRECTOR OF TRANSPORTATION /COUNTY ENGINEER, KANE COUNTY

PASSED APRIL 10 2009
CHRISTOPHER HOLT
DISTRICT ONE ENGINEER OF LOCAL ROADS & STREETS

RELEASING FOR BID
BASED ON LIMITED
REVIEW APRIL 7, 2009
Diana M. O'Keefe
DEPUTY DIRECTOR OF HIGHWAYS, REGION ONE ENGINEER

APPLIES TO SHEETS 51-62	APPLIES TO SHEETS 74-76; 123-129
REGISTERED P.E., STATE OF ILLINOIS EXPIRES 11/30/09	REGISTERED S.E., STATE OF ILLINOIS EXPIRES 11/30/10
APPLIES TO SHEETS 99-122	APPLIES TO SHEETS 1-50; 63-73; 89-98; 137-220
REGISTERED P.E., STATE OF ILLINOIS EXPIRES 11/30/09	REGISTERED P.E., STATE OF ILLINOIS EXPIRES 11/30/09



PLANS PREPARED BY:
CIVILTECH
450 E. Devon Ave. Suite 300 - Itasca, Illinois 60143
Tel: 630.773.3900 - Fax: 630.773.3975
www.civiltechinc.com

PRINTED BY THE AUTHORITY OF THE STATE OF ILLINOIS

CONSULTANT ENGINEER: DEREK N. MALL, P.E. CIVILTECH ENGINEERING, INC.

PROJECT MANAGER JESSICA A. FELICIANO, P.E.
CONTRACT NO. 63076

INDEX OF SHEETS

1	COVER SHEET & INDEX OF SHEETS
2-3	GENERAL NOTES AND LIST OF STATE AND LOCAL STANDARDS
4-5	SUMMARY OF QUANTITIES
6-11	EXISTING & PROPOSED TYPICAL SECTIONS
12-19	EARTHWORK & SCHEDULE OF QUANTITIES
20-21	ALIGNMENT, TIES & BENCHMARKS
22-24	SUPERELEVATION TABLES
25-27	EXISTING CONDITIONS AND REMOVAL PLAN
28-36	PLAN AND PROFILE
37-50	MAINTENANCE OF TRAFFIC GENERAL NOTES, TYPICAL SECTIONS, & PLAN
51-59	LANDSCAPE RESTORATION & EROSION CONTROL PLAN
60-62	STORM WATER POLLUTION PREVENTION
63-76	DRAINAGE AND UTILITIES & STORMWATER DETENTION DETAILS
77-79	SUBSURFACE UTILITY EXPLORATION PLANS
80-88	PLAT OF HIGHWAYS
89-94	JOINTING PLAN & INTERSECTION GRADING DETAILS
95-98	PAVEMENT MARKING AND SIGNING
99-122	TRAFFIC SIGNAL PLAN AND DETAILS
123-129	STRUCTURAL PLANS
130-136	SOIL BORING PLAN & SOIL PROFILE
137-145	CONSTRUCTION DETAILS
146-220	CROSS SECTIONS

SPECIFICATIONS, STANDARDS AND SPECIAL PROVISIONS

- ALL CONSTRUCTION SHALL BE IN ACCORDANCE WITH THE "STANDARD SPECIFICATIONS FOR ROAD AND BRIDGE CONSTRUCTION" ("STANDARD SPECIFICATIONS"), ADOPTED JANUARY 1, 2007; THE "SUPPLEMENTAL SPECIFICATIONS AND RECURRING SPECIAL PROVISIONS", ADOPTED JANUARY 1, 2009; THE LATEST EDITION OF THE "ILLINOIS MANUAL ON UNIFORM TRAFFIC CONTROL DEVICES FOR STREETS AND HIGHWAYS", (IMUTCD); "THE STANDARD SPECIFICATIONS FOR WATER AND SEWER MAIN CONSTRUCTION IN ILLINOIS" MAY 1996 FIFTH EDITION, THE DETAILS IN THE PLANS, AND THE SPECIAL PROVISIONS AND IDOT STANDARD DRAWINGS INCLUDED IN THE CONTRACT DOCUMENTS.
- ALL REFERENCES TO "ENGINEER" SHALL BE INTERPRETED AS THE RESIDENT ENGINEER.
- ALL UTILITY COMPANIES, SCHOOL DISTRICTS, AND LOCAL POLICE AND FIRE DEPARTMENTS SHALL BE NOTIFIED BY THE CONTRACTOR AT LEAST 72 HOURS PRIOR TO THE START OF CONSTRUCTION.

STAKING

- ALL RADII FOR PROPOSED CURB AND GUTTER ARE TO THE EDGE OF PAVEMENT UNLESS OTHERWISE NOTED.
- THE STATION/OFFSET/ELEVATIONS NOTED FOR ALL DRAINAGE STRUCTURES LOCATED IN THE CURB LINE REFER TO THE POSITION OF THE ADJACENT EDGE OF PAVEMENT. THE CONTRACTOR SHALL BE RESPONSIBLE FOR DETERMINING THE OFFSET NECESSARY FOR EACH STRUCTURE TO SET THE FRAME AND GRATE IN THE PROPER LOCATION. ALL OTHER STRUCTURES ARE DIMENSIONED TO THE CENTER OF STRUCTURE, UNLESS OTHERWISE NOTED.
- PAVEMENT GRADES: THE ELEVATIONS INDICATED ON THE PLANS ARE FINISHED GRADES OF PROPOSED PAVEMENT, UNLESS OTHERWISE INDICATED.
- THE CONSTRUCTION BASELINE HAS BEEN ESTABLISHED FOR STAKING PURPOSES ONLY AND IS NOT INTENDED TO BE A CENTERLINE OF RIGHT-OF-WAY.
- THE CONTRACTOR SHALL PROTECT AND CAREFULLY PRESERVE ALL SECTION OR SUBSECTION MONUMENTS OR PROPERTY OR REFERENCE MARKERS UNTIL THE VILLAGE, THE COUNTY, ITS AGENT OR AN AUTHORIZED SURVEYOR HAS WITNESSED OR OTHERWISE REFERENCED THEIR LOCATIONS.

PAVING AND CURB & GUTTER

- THE CONTRACTOR SHALL SAW CUT PAVEMENT, CURB & GUTTER, MEDIAN AND SIDEWALK AS INDICATED ON THE PLANS TO SEPARATE THE EXISTING MATERIAL TO BE REMOVED BY MEANS OF AN APPROVED SAW TO FULL DEPTH AS SHOWN ON THE PLANS OR AS DIRECTED BY THE ENGINEER. THIS WORK SHALL BE CONSIDERED INCIDENTAL TO THE ITEM BEING REMOVED.

THE CONTRACTOR SHALL BE REQUIRED TO SAW VERTICAL CUTS SO AS TO FORM CLEAN VERTICAL JOINTS. SHOULD THE CONTRACTOR DEFACE ANY EDGE, A NEW SAWED JOINT SHALL BE PROVIDED AND ANY ADDITIONAL WORK, INCLUDING REMOVAL AND REPLACEMENT, SHALL BE DONE AT THE CONTRACTOR'S EXPENSE.
- BINDER COURSE SHALL NOT BE PLACED ADJACENT TO CURB AND GUTTER UNTIL THE CURB AND GUTTER HAS BEEN PROPERLY CURED AND BACKFILLED TO THE SATISFACTION OF THE ENGINEER.
- HOT-MIX ASPHALT SURFACE COURSE SHALL NOT BE PLACED UNTIL ALL EARTH EXCAVATION, TOPSOIL PLACEMENT, AND HOT-MIX ASPHALT BINDER COURSE HAVE BEEN COMPLETED TO THE SATISFACTION OF THE ENGINEER.
- THE THICKNESSES OF HOT-MIX ASPHALT MIXTURES SHOWN ON THE PLANS ARE NOMINAL. DEVIATIONS MAY OCCUR DUE TO IRREGULARITIES IN THE BINDER OR BASE UPON WHICH THE HOT-MIX ASPHALT MATERIALS ARE PLACED.
- DRIVEWAY PAVEMENT REMOVAL SHALL INCLUDE FROM TOP OF DRIVEWAY TO BOTTOM OF PROPOSED AGGREGATE BASE COURSE.
- MILLING OF RANDALL ROAD FOR RESURFACING SHALL NOT BE PERMITTED UNTIL THE CONTRACTOR IS READY TO PLACE SURFACE ON THE H.M.A. PAVEMENT OF STEARNS ROAD, OR AS DIRECTED BY THE ENGINEER.

EXCAVATION

- ALL EXCESS MATERIAL (BROKEN CONCRETE, SEWER PIPE, WASTE ROADWAY EXCAVATION AND SURPLUS MATERIAL FROM SEWER TRENCHES) SHALL BE LEGALLY DISPOSED OF OUTSIDE THE LIMITS OF THE RIGHT-OF-WAY. IT SHALL BE THE CONTRACTOR'S RESPONSIBILITY TO SELECT DUMP SITES AND OBTAIN PERMISSION AND ALL NECESSARY PERMITS TO USE SUCH DUMP SITES. THE COST OF THIS WORK SHALL BE INCLUDED IN THE COST OF THE REMOVAL ITEMS IN THE CONTRACT.
- POROUS GRANULAR EMBANKMENT, SUBGRADE HAS BEEN PROVIDED TO REPLACE SOILS WHICH TEND TO BE UNSTABLE WHEN WET. THE ACTUAL NEED FOR REMOVAL AND REPLACEMENT WITH PGES WILL BE DETERMINED IN THE FIELD AT THE TIME OF CONSTRUCTION BY THE ENGINEER. IF UNSUITABLE SOILS ARE ENCOUNTERED THE SOILS SHALL BE REMOVED AND REPLACED WITH PGES. THE REMOVAL AND REPLACEMENT AREA SHALL EXTEND TO 12 INCHES BEYOND THE CURB AND GUTTER AND COME UP AT A 1:1 SLOPE TO EXISTING GROUND SURFACE. THESE LIMITS MAY BE ALTERED BY THE ENGINEER IF FIELD CONDITIONS SO WARRANT. GEOTECHNICAL FABRIC FOR GROUND STABILIZATION SHALL BE PLACED BETWEEN THE EXISTING SUBGRADE AND THE PROPOSED PGES. REMOVAL OF THESE UNSUITABLE SOILS SHALL BE PAID FOR AS "REMOVAL AND DISPOSAL OF UNSUITABLE MATERIAL."
- EMBANKMENT MATERIAL USED FOR THE CONSTRUCTION OF POND 2A SHALL BE CLAY MATERIAL ONLY AS APPROVED BY THE ENGINEER TO PREVENT EXCESSIVE PERMEATION OF WATER.

SEWER

- THE COST OF MAKING SEWER CONNECTIONS TO EXISTING OR PROPOSED SEWER OR DRAINAGE STRUCTURES SHALL BE INCIDENTAL TO THE COST OF THE SEWER OR STRUCTURE BEING CONSTRUCTED.
- UNLESS OTHERWISE NOTED ON THE PLANS, THE EXISTING DRAINAGE FACILITIES SHALL REMAIN IN USE DURING THE PERIOD OF CONSTRUCTION. LOCATIONS OF EXISTING DRAINAGE STRUCTURES AND SEWERS AS SHOWN ON THE PLANS ARE APPROXIMATE. PRIOR TO COMMENCING WORK THE CONTRACTOR, AT HIS OWN EXPENSE, SHALL DETERMINE THE EXACT LOCATIONS OF EXISTING STRUCTURES WHICH ARE WITHIN THE PROPOSED CONSTRUCTION LIMITS. DURING CONSTRUCTION, IF THE CONTRACTOR ENCOUNTERS OR OTHERWISE BECOMES AWARE OF ANY SEWERS, UNDERDRAINS OR FIELD DRAINS WITHIN THE RIGHT-OF-WAY OTHER THAN THOSE SHOWN ON THE PLANS, HE SHALL SO INFORM THE ENGINEER, WHO SHALL DIRECT THE WORK NECESSARY TO MAINTAIN OR REPLACE THE FACILITIES IN SERVICE AND TO PROTECT THEM FROM DAMAGE DURING CONSTRUCTION IF MAINTAINED. EXISTING FACILITIES TO BE MAINTAINED THAT ARE DAMAGED BECAUSE OF THE NON-COMPLIANCE WITH THIS PROVISION SHALL BE REPLACED AT THE CONTRACTOR'S OWN EXPENSE. SHOULD THE ENGINEER HAVE DIRECTED THE REPLACEMENT OF A FACILITY, THE NECESSARY WORK AND PAYMENT SHALL BE IN ACCORDANCE WITH SECTIONS 550 AND 601, AND ARTICLE 104.02 OF THE STANDARD SPECIFICATIONS.
- WHEN EXISTING DRAINAGE FACILITIES ARE DISTURBED, THE CONTRACTOR SHALL PROVIDE AND MAINTAIN TEMPORARY OUTLETS AND CONNECTIONS FOR ALL PRIVATE OR PUBLIC DRAINS, SEWERS OR CATCH BASINS. THE CONTRACTOR SHALL PROVIDE FACILITIES TO TAKE IN ALL STORM WATER WHICH WILL BE RECEIVED BY THESE DRAINS AND SEWERS AND DISCHARGE THE SAME. HE SHALL PROVIDE AND MAINTAIN AN EFFICIENT PUMPING PLANT, IF NECESSARY, AND A TEMPORARY OUTLET. HE SHALL BE PREPARED AT ALL TIMES TO DISPOSE OF THE WATER RECEIVED FROM TEMPORARY CONNECTIONS UNTIL SUCH TIME AS THE PERMANENT CONNECTIONS WITH SEWER ARE BUILT AND IN SERVICE. THIS WORK WILL NOT BE PAID FOR SEPARATELY, BUT SHALL BE INCLUDED IN THE CONTRACT.
- ALL ABANDONED PIPE AND STRUCTURE INVERTS SHALL BE PLUGGED WITH BRICK AND MORTAR TO THE SATISFACTION OF THE ENGINEER. THIS WORK SHALL BE INCIDENTAL TO THE SEWER ITEMS BEING REMOVED.
- TOP OF FRAME ("RIM") ELEVATIONS GIVEN ON THE PLANS ARE ONLY TO ASSIST THE CONTRACTOR IN DETERMINING THE APPROXIMATE OVERALL HEIGHT OF EACH STRUCTURE. FRAMES ON ALL NEW STRUCTURES SHALL BE ADJUSTED TO THE FINAL ELEVATIONS OF THE AREAS IN WHICH THEY ARE LOCATED, AS PART OF THE STRUCTURE COST.
- DRAINAGE STRUCTURE FLAT-TOPS AND CONES SHALL BE TURNED SO THAT THE FRAMES ARE CLOSEST TO THE CENTERLINE OF THE ROAD. ALL FLAT-TOPS AND CONES ARE ASSUMED TO BE ECCENTRIC.
- ALL SEWER AND WATER SERVICES CROSSED BY NEW STORM SEWERS SHALL BE PROPERLY LOCATED AND PROTECTED DURING CONSTRUCTION. ANY DAMAGE TO SAID SERVICES NOT CONSIDERED TO BE IN CONFLICT WITH THE PROPOSED STORM SEWER SHALL BE REPAIRED BY THE CONTRACTOR AT HIS OWN EXPENSE.

TREE REMOVAL, CLEARING, AND HEDGE REMOVAL

- ALL TREE TRUNK PROTECTION, TREE REMOVAL, PRUNING AND ROOT PRUNING SHALL BE COMPLETED BEFORE CONSTRUCTION OPERATIONS COMMENCE IN ANY AREA. AT NO TIME SHALL THE CONTRACTOR PRUNE OR REMOVE ANY TREES UNLESS DIRECTED BY THE ENGINEER.
- WHEN TREE TRUNK PROTECTION REQUIRES TEMPORARY FENCING, IT SHALL BE ERECTED ALONG THE DRIP LINE OF EXISTING TREES TO REMAIN WITHIN THE LIMITS OF CONSTRUCTION OR AS DIRECTED BY THE ENGINEER. AFTER TREES ARE SAFELY FENCED, NOTHING IS TO BE STORED, DRIVEN, OR DISTURBED INSIDE THE FENCED AREA. PROTECTIVE TEMPORARY FENCE IS TO BE REMOVED ONLY AFTER ALL CONSTRUCTION WORK HAS BEEN COMPLETED.
- CONTRACTOR SHALL PAY SPECIAL ATTENTION TO ARTICLE 201.01(d) OF THE STANDARD SPECIFICATIONS. REMOVAL OF ALL OBSTRUCTIONS IN THE RIGHT-OF-WAY, THAT ARE NOT INCLUDED IN A SPECIFIC REMOVAL ITEM, SHALL BE CONSIDERED CLEARING AND INCLUDED IN THE COST OF THE CONTRACT. THIS SHALL INCLUDE, BUT NOT LIMITED TO, FENCES, WALLS, FOUNDATIONS, BUILDINGS, WOODEN POWER POLES, GATES, AND ALL VEGETATION, TREES, SHRUBS, ETC. LESS THAN 6" IN DIAMETER.

SIGNING, STRIPING & LANDSCAPING

- THE CONTRACTOR SHALL ADHERE TO LIMITS OF RESTORATION SHOWN. AREAS OUTSIDE THESE LIMITS THAT ARE DAMAGED OR DISTURBED BY THE CONTRACTOR SHALL BE RESTORED BY THE CONTRACTOR AT HIS EXPENSE, AND NO ADDITIONAL COMPENSATION WILL BE ALLOWED.
- ALL NEW SIGNING WILL BE FURNISHED AND INSTALLED BY KANE COUNTY. SIGNS ON THE PROPOSED PAVEMENT MARKING AND SIGNING SHEET ARE FOR REFERENCE ONLY FOR KCDOT.

SUMMARY OF QUANTITIES

CODE NUMBER	ITEM	UNIT	ROADWAY J000-2A	TRAFFIC SIGNALS Y031-F	MSE RETAINING WALL Y007	TOTAL QUANTITY
20100110	TREE REMOVAL (6 TO 15 UNITS DIAMETER)	UNIT	1,640			1,640
20100210	TREE REMOVAL (OVER 15 UNITS DIAMETER)	UNIT	457			457
20101000	TEMPORARY FENCE	FOOT	2,440			2,440
20101100	TREE TRUNK PROTECTION	EACH	61			61
20200100	EARTH EXCAVATION	CU YD	369,402			369,402
20200300	EARTH EXCAVATION FOR EROSION CONTROL	CU YD	8,000			8,000
20201200	REMOVAL AND DISPOSAL OF UNSUITABLE MATERIAL	CU YD	1,242			1,242
20700400	POROUS GRANULAR EMBANKMENT, SPECIAL	CU YD	72		594	666
20700420	POROUS GRANULAR EMBANKMENT, SUBGRADE	CU YD	1,242			1,242
20800150	TRENCH BACKFILL	CU YD	2,337			2,337
21001000	GEOTECHNICAL FABRIC FOR GROUND STABILIZATION	SQ YD	19,657			19,657
21101615	TOPSOIL FURNISH AND PLACE, 4"	SQ YD	122,052			122,052
21101685	TOPSOIL FURNISH AND PLACE, 24"	SQ YD	7,577			7,577
21300010	EXPLORATION TRENCH, SPECIAL	FOOT	200			200
25000350	SEEDING, CLASS 7	ACRE	24.05			24.05
25000400	NITROGEN FERTILIZER NUTRIENT	POUND	2,156			2,156
25000500	PHOSPHORUS FERTILIZER NUTRIENT	POUND	2,156			2,156
25000600	POTASSIUM FERTILIZER NUTRIENT	POUND	2,156			2,156
25100115	MULCH, METHOD 2	ACRE	24.87			24.87
28000500	INLET AND PIPE PROTECTION	EACH	6			6
28000510	INLET FILTERS	EACH	83			83
28100101	STONE RIPRAP, CLASS A1	SQ YD	100			100
28100105	STONE RIPRAP, CLASS A3	SQ YD	368			368
28100107	STONE RIPRAP, CLASS A4	SQ YD	172			172
28100111	STONE RIPRAP, CLASS A6	SQ YD	104			104
28200200	FILTER FABRIC	SQ YD	744			744
31101000	SUB-BASE GRANULAR MATERIAL, TYPE B	TON	517			517
35101800	AGGREGATE BASE COURSE, TYPE B 6"	SQ YD	431			431
35501316	HMA BASE COURSE, 8"	SQ YD	427			427
40201000	AGGREGATE FOR TEMPORARY ACCESS	TON	595			595
40600100	BITUMINOUS MATERIALS (PRIME COAT)	GALLON	1,435			1,435
40600300	AGGREGATE (PRIME COAT)	TON	29			29
40600895	CONSTRUCTING TEST STRIP	EACH	1			1
40600990	TEMPORARY RAMP	SQ YD	1,602			1,602
40603310	HMA SURFACE COURSE, MIX "C", N50	TON	51			51
40603595	POLYMERIZED HOT-MIX ASPHALT SURFACE COURSE, MIX "F", N90	TON	961			961
40701896	HOT-MIX ASPHALT PAVEMENT (FULL-DEPTH), 10 3/4"	SQ YD	2,458			2,458
42000501	PORTLAND CEMENT CONCRETE PAVEMENT 10" (JOINTED)	SQ YD	48,436			48,436
44000100	PAVEMENT REMOVAL	SQ YD	20,427			20,427
44000157	HOT-MIX ASPHALT SURFACE REMOVAL, 2"	SQ YD	8,578			8,578
44000200	DRIVEWAY PAVEMENT REMOVAL	SQ YD	1,195			1,195
44000500	COMBINATION CURB AND GUTTER REMOVAL	FOOT	302			302
44201796	CLASS D PATCHES, TYPE IV, 12 INCH	SQ YD	523			523
48101500	AGGREGATE SHOULDERS, TYPE B 6"	SQ YD	2,394			2,394
48203021	HOT-MIX ASPHALT SHOULDERS, 6"	SQ YD	404			404
48301000	PROTECTIVE COAT	SQ YD	62,360			62,360
50105220	PIPE CULVERT REMOVAL	FOOT	273			273
50200100	STRUCTURE EXCAVATION	CU YD			2260	2,260
50300285	FORM LINER TEXTURED SURFACE	SQ FT			8,289	8,289
54213657	PRECAST REINFORCED CONCRETE FLARED END SECTIONS 12"	EACH	15			15
54213660	PRECAST REINFORCED CONCRETE FLARED END SECTIONS 15"	EACH	1			1
54213663	PRECAST REINFORCED CONCRETE FLARED END SECTIONS 18"	EACH	17			17
54213669	PRECAST REINFORCED CONCRETE FLARED END SECTIONS 24"	EACH	7			7
54213675	PRECAST REINFORCED CONCRETE FLARED END SECTIONS 30"	EACH	1			1
54213705	PRECAST REINFORCED CONCRETE FLARED END SECTIONS 60"	EACH	1			1
54247130	GRATING FOR CONCRETE FLARED END SECTION 24"	EACH	7			7
54247150	GRATING FOR CONCRETE FLARED END SECTION 30"	EACH	1			1
54247210	GRATING FOR CONCRETE FLARED END SECTION 60"	EACH	1			1
542A0223	PIPE CULVERTS, CLASS A, TYPE 1 18"	FOOT	64			64
542A1063	PIPE CULVERTS, CLASS A, TYPE 2 18"	FOOT	216			216
550A0050	STORM SEWERS, CLASS A, TYPE 1 12"	FOOT	504			504
550A0090	STORM SEWERS, CLASS A, TYPE 1 18"	FOOT	98			98
550A0120	STORM SEWERS, CLASS A, TYPE 1 24"	FOOT	1,222			1,222
550A0340	STORM SEWERS, CLASS A, TYPE 2 12"	FOOT	1,165			1,165
550A0360	STORM SEWERS, CLASS A, TYPE 2 15"	FOOT	103			103
550A0380	STORM SEWERS, CLASS A, TYPE 2 18"	FOOT	164			164
550A0410	STORM SEWERS, CLASS A, TYPE 2 24"	FOOT	1,363			1,363
550A0430	STORM SEWERS, CLASS A, TYPE 2 30"	FOOT	190			190
550A0450	STORM SEWERS, CLASS A, TYPE 2 36"	FOOT	245			245
550A0480	STORM SEWERS, CLASS A, TYPE 2 48"	FOOT	215			215
550A0500	STORM SEWERS, CLASS A, TYPE 2 60"	FOOT	89			89
550A0730	STORM SEWERS, CLASS A, TYPE 3 30"	FOOT	412			412
550A0800	STORM SEWERS, CLASS A, TYPE 3 60"	FOOT	192			192
550A1100	STORM SEWERS, CLASS A, TYPE 4 60"	FOOT	163			163
55035300	STORM SEWERS, TYPE 2, REINFORCED CONCRETE ELLIPTICAL PIPE, SPAN 23, RISE 14	FOOT	44			44
55103100	DUCTILE IRON WATER MAIN 8"	FOOT	134			134
55105000	WATER VALVES 8"	EACH	1			1
55400200	FIRE HYDRANTS TO BE MOVED (SPECIAL)	EACH	6			6
55400820	FIRE HYDRANT WITH AUXILIARY VALVE AND VALVE BOX	EACH	1			1
60100060	CONCRETE HEADWALL FOR PIPE DRAIN	EACH	23			23
60107700	PIPE UNDERDRAINS 6"	FOOT	3,113			3,113
60200805	CATCH BASINS, TYPE A, 4'-DIAMETER, TYPE 8 GRATE	EACH	11			11
60205040	CATCH BASINS, TYPE A, 5'-DIAMETER, TYPE 24 FRAME AND GRATE	EACH	1			1
60207605	CATCH BASINS, TYPE C, TYPE 8 GRATE	EACH	2			2

* DENOTES SPECIALTY ITEM

CODE NUMBER	ITEM	UNIT	ROADWAY J000-2A	TRAFFIC SIGNALS Y031-F	MSE RETAINING WALL Y007	TOTAL QUANTITY
60208230	CATCH BASINS, TYPE C, TYPE 23 FRAME AND GRATE	EACH	1			1
60208240	CATCH BASINS, TYPE C, TYPE 24 FRAME AND GRATE	EACH	9			9
60214400	RESTRICTED DEPTH CATCH BASINS, 4'-DIAMETER, TYPE 8 GRATE	EACH	1			1
60214713	RESTRICTED DEPTH CATCH BASINS, 4'-DIAMETER, TYPE 23 FRAME AND GRATE	EACH	4			4
60214714	RESTRICTED DEPTH CATCH BASINS, 4'-DIAMETER, TYPE 24 FRAME AND GRATE	EACH	13			13
60216613	RESTRICTED DEPTH CATCH BASINS, 5'-DIAMETER, TYPE 23 FRAME AND GRATE	EACH	1			1
60216614	RESTRICTED DEPTH CATCH BASINS, 5'-DIAMETER, TYPE 24 FRAME AND GRATE	EACH	6			6
60221100	MANHOLES, TYPE A, 5'-DIAMETER, TYPE 1 FRAME, CLOSED LID	EACH	2			2
60224446	MANHOLES, TYPE A, 7'-DIAMETER, TYPE 1 FRAME, CLOSED LID	EACH	1			1
60224600	RESTRICTED DEPTH MANHOLES, 4'-DIAMETER, TYPE 1 FRAME, CLOSED LID	EACH	1			1
60225400	RESTRICTED DEPTH MANHOLES, 5'-DIAMETER, TYPE 1 FRAME, CLOSED LID	EACH	6			6
60225900	RESTRICTED DEPTH MANHOLES, 5'-DIAMETER, TYPE 8 GRATE	EACH	2			2
60226200	RESTRICTED DEPTH MANHOLES, 6'-DIAMETER, TYPE 1 FRAME, CLOSED LID	EACH	2			2
60236200	INLETS, TYPE A, TYPE 8 GRATE	EACH	8			8
60236700	INLETS, TYPE A, TYPE 10 FRAME AND GRATE	EACH	2			2
60237460	INLETS, TYPE A, TYPE 23 FRAME AND GRATE	EACH	2			2
60237470	INLETS, TYPE A, TYPE 24 FRAME AND GRATE	EACH	10			10
60240305	INLETS, TYPE B, TYPE 10 FRAME AND GRATE	EACH	1			1
60240327	INLETS, TYPE B, TYPE 23 FRAME AND GRATE	EACH	2			2
60240328	INLETS, TYPE B, TYPE 24 FRAME AND GRATE	EACH	3			3
60248700	VALVE VAULTS, TYPE A, 4'-DIAMETER, TYPE 1 FRAM, CLOSED LID	EACH	1			1
60255500	MANHOLES TO BE ADJUSTED	EACH	4			4
60257900	MANHOLES TO BE RECONSTRUCTED	EACH	2			2
60600095	CLASS SIC CONCRETE (OUTLET)	CU YD	3.8			3.8
60602500	CONCRETE GUTTER, TYPE A	FOOT	946			946
60603800	COMBINATION CONCRETE CURB AND GUTTER, TYPE B-6.12	FOOT	169			169
60605000	COMBINATION CONCRETE CURB AND GUTTER, TYPE B-6.24	FOOT	14,093			14,093
60608600	COMBINATION CONCRETE CURB AND GUTTER, TYPE M-6.06	FOOT	18			18
60618300	CONCRETE MEDIAN SURFACE, 4 INCH	SQ FT	162			162
60620000	CONCRETE MEDIAN, TYPE SB-6.24	SQ FT	2,030			2,030
60620200	CONCRETE MEDIAN, TYPE SB-6.24 (MODIFIED)	SQ FT	8,121			8,121
60624600	CORRUGATED MEDIAN	SQ FT	424			424
* 63000001	STEEL PLATE BEAM GUARD RAIL, TYPE A, 6 FOOT POSTS	FOOT	1,168			1,168
* 63100045	TRAFFIC BARRIER TERMINAL, TYPE 2	EACH	1			1
* 63100167	TRAFFIC BARRIER TERMINAL, TYPE 1 (SPECIAL) TANGENT	EACH	1			1
67100100	MOBILIZATION	L SUM	1			1
70100100	TRAFFIC CONTROL AND PROTECTION, STANDARD 701316	EACH	1			1
70101700	TRAFFIC CONTROL AND PROTECTION	L SUM	1			1
70108800	CHANGEABLE MESSAGE SIGN	CAL MO	36			36
70300210	TEMPORARY PAVEMENT MARKING - LETTERS AND SYMBOLS	SQ FT	277			277
70300220	TEMPORARY PAVEMENT MARKING - LINE 4"	FOOT	11,943			11,943
* 70300510	PAVEMENT MARKING TAPE, TYPE III - LETTERS AND SYMBOLS	SQ FT	230			230
* 70300520	PAVEMENT MARKING TAPE, TYPE III 4"	FOOT	18,958			18,958
* 70301000	WORK ZONE PAVEMENT MARKING REMOVAL	SQ FT	13,365			13,365
* 70106500	TEMPORARY BRIDGE TRAFFIC SIGNALS	EACH	1			1
* 78001110	PAINT PAVEMENT MARKING - LINE 4"	FOOT	1088			1088
* 78001150	PAINT PAVEMENT MARKING - LINE 12"	FOOT	95			95
* 78005100	EPOXY PAVEMENT MARKING - LETTERS AND SYMBOLS	SQ FT	692			692
* 78005110	EPOXY PAVEMENT MARKING - LINE 4"	FOOT	842			842
* 78005130	EPOXY PAVEMENT MARKING - LINE 6"	FOOT	2,774			2,774
* 78005140	EPOXY PAVEMENT MARKING - LINE 8"	FOOT	613			613
* 78005150	EPOXY PAVEMENT MARKING - LINE 12"	FOOT	313			313
* 78005180	EPOXY PAVEMENT MARKING - LINE 24"	FOOT	285			285
* 78008200	POLYUREA PAVEMENT MARKING TYPE I - LETTERS AND SYMBOLS	SQ FT	1,859			1,859
* 78008210	POLYUREA PAVEMENT MARKING TYPE I - LINE 4"	FOOT	31,933			31,933
* 78008230	POLYUREA PAVEMENT MARKING TYPE I - LINE 6"	FOOT	3,592			3,592
* 78008240	POLYUREA PAVEMENT MARKING TYPE I - LINE 8"	FOOT	312			312
* 78008250	POLYUREA PAVEMENT MARKING TYPE I - LINE 12"	FOOT	95			95
* 78008270	POLYUREA PAVEMENT MARKING TYPE I - LINE 24"	FOOT	57			57
* 78201000	TERMINAL MARKER-DIRECT APPLIED	EACH	1			1
* 78200420	GUARDRAIL MARKERS, TYPE B	EACH	7			7
* 81000600	CONDUIT IN TRENCH, 2" DIA., GALVANIZED STEEL	FOOT		533		533
* 81000700	CONDUIT IN TRENCH, 2 1/2" DIA., GALVANIZED STEEL	FOOT		56		56
* 81000800	CONDUIT IN TRENCH, 3" DIA., GALVANIZED STEEL	FOOT		122		122
* 81001000	CONDUIT IN TRENCH, 4" DIA., GALVANIZED STEEL	FOOT		192		192
* 81001100	CONDUIT IN TRENCH, 5" DIA., GALVANIZED STEEL	FOOT		10		10
* 81018900	CONDUIT PUSHED, 4" DIA., GALVANIZED STEEL	FOOT		580		580
* 81400100	HANDHOLE	EACH		5		5
* 81400300	DOUBLE HANDHOLE	EACH		2		2
* 81900200	TRENCH AND BACKFILL FOR ELECTRICAL WORK	FOOT		806		806
* 85000200	MAINTENANCE OF EXISTING TRAFFIC SIGNAL INSTALLATION	EACH		3		3
* 85700205	FULL-ACTUATED CONTROLLER AND TYPE IV CABINET (SPECIAL)	EACH		1		1
* 87301225	ELECTRIC CABLE IN CONDUIT, SIGNAL NO. 14 3C	FOOT		1,336		1,336
* 87301245	ELECTRIC CABLE IN CONDUIT, SIGNAL NO. 14 5C	FOOT		5,034		5,034
* 87301255	ELECTRIC CABLE IN CONDUIT, SIGNAL NO. 14 7C	FOOT		2,250		2,250
* 87301805	ELECTRIC CABLE IN CONDUIT, SERVICE, NO. 6 2C	FOOT		51		51
* 87301305	ELECTRIC CABLE IN CONDUIT, LEAD-IN NO.14 1 PAIR	FOOT		3,218		3,218
* 87502500	TRAFFIC SIGNAL POST, GALVANIZED STEEL, 16 FT.	EACH		4		4
* 87800100	CONCRETE FOUNDATION, TYPE A	FOOT		16		16
* 87800200	CONCRETE FOUNDATION, TYPE D	FOOT		4		4

SUMMARY OF QUANTITIES

CODE NUMBER	ITEM	UNIT	ROADWAY J000-2A	TRAFFIC SIGNALS Y031-F	MSE RETAINING WALL Y007	TOTAL QUANTITY
* 87900200	DRILL EXISTING HANDHOLE	EACH		3		3
* 88030020	SIGNAL HEAD, L.E.D., 1-FACE, 3-SECTION, MAST ARM MOUNTED	EACH		12		12
* 88030110	SIGNAL HEAD, L.E.D., 1-FACE, 5-SECTION, MAST ARM MOUNTED	EACH		4		4
* 88030240	SIGNAL HEAD, L.E.D., 2-FACE, 1-3 SECTION, 1-5 SECTION, BRACKET MOUNTED	EACH		4		4
* 88200210	TRAFFIC SIGNAL BACKPLATE, LOUVERED, ALUMINUM	EACH		16		16
* 88500100	INDUCTIVE LOOP DETECTOR	EACH		11		11
* 88600100	DETECTOR LOOP, TYPE 1	FOOT		328		328
* 88700200	LIGHT DETECTOR	EACH		4		4
* 88700300	LIGHT DETECTOR AMPLIFIER	EACH		1		1
* 89502300	REMOVE ELECTRICAL CABLE FROM CONDUIT	FOOT		3,776		3776
* 89502380	REMOVE EXISTING HANDHOLE	EACH		3		3
* 89502500	REMOVE TEMPORARY TRAFFIC SIGNAL INSTALLATION	EACH		1		1
X0322033	STORM SEWER (WATER MAIN REQUIREMENTS) 12 INCH	FOOT	194			194
X0322035	STORM SEWER (WATER MAIN REQUIREMENTS) 18 INCH	FOOT	142			142
* X0322370	PREFORMED DETECTOR LOOP	FOOT		137		137
* X0322925	ELECTRIC CABLE IN CONDUIT, TRACER, NO. 14 1C	FOOT		5,410		5410
X0323426	SEDIMENT CONTROL, DRAINAGE STRUCTURE INLET FILTER CLEANING	EACH	249			249
X0323973	SEDIMENT CONTROL, SILT FENCE	FOOT	3641			3641
X0323974	SEDIMENT CONTROL, SILT FENCE MAINTENANCE	FOOT	3641			3641
X0324045	SEDIMENT CONTROL, STABILIZED CONSTRUCTION ENTRANCE REMOVAL	EACH	2			2
X0324774	SEDIMENT CONTROL, STABILIZED CONSTRUCTION ENTRANCE	SQ YD	555			555
X0324775	SEDIMENT CONTROL, STABILIZED CONSTRUCTION ENTRANCE MAINTENANCE	SQ YD	555			555
X0325110	BIAXIAL GEOGRID	SQ YD	115		887	1002
X0325375	MANHOLES, TYPE A, SPECIAL, 9'-DIAMETER, TYPE 1 FRAME, CLOSED LID	EACH	1			1
* X0325705	RE-OPTIMIZE TRAFFIC SIGNAL SYSTEM, LEVEL 2	EACH		1		1
* X0325737	TEMPORARY TRAFFIC SIGNAL TIMING	EACH		1		1
* X8050015	SERVICE INSTALLATION - POLE MOUNTED	EACH		1		1
* X8620020	UNINTERRUPTIBLE POWER SUPPLY	EACH		1		1
* X8730027	ELECTRIC CABLE IN CONDUIT, GROUNDING, NO. 6 1C	FOOT		903		903
* X8730250	ELECTRIC CABLE IN CONDUIT, NO. 20 3/C, TWISTED, SHIELDED	FOOT		1,336		1336
* X8900040	MODIFY TEMPORARY TRAFFIC SIGNAL INSTALLATION	EACH		1		1
XX003404	TEMPORARY PAVEMENT 8"	SQ YD	1,965			1965
● XX003536	CONNECTION TO EXISTING WATER MAINS (NON PRESSURE)	EACH	1			1
Z0034210	MECHANICALLY STABILIZED EARTH RETAINING WALL	SQ FT			8289	8289
XX004592	MANHOLES, TYPE A, 6'-DIAMETER, TYPE 1 FRAME, CLOSED LID, RESTRICTOR PLATE	EACH	1			1
XX004878	MAINTENANCE OF TEMPORARY EROSION CONTROL SYSTEMS	L SUM	1			1
* XX004913	REMOVE FIBER OPTIC CABLE FROM CONDUIT	FOOT		3776		3776
* XX005723	VIDEO DETECTION SYSTEM COMPLETE INTERSECTION	EACH		1		1
* XX006257	RECESSED REFLECTIVE PAVMENT MARKER	EACH	44			44
* XX006258	STEEL CASING PIPE 18"	FOOT	96			96
* XX006338	EROSION CONTROL BLANKET (SPECIAL 2)	SQ YD	5856			5856
* XX006654	FIBER OPTIC CABLE IN CONDUIT, NO. 62.5/125, MM12F SM24F	FOOT		5,482		5482
* XX006701	SEEDING, CLASS 4 (MODIFIED) MESIC PRAIRIE	ACRE	2.03			2.03
* XX006709	SEEDING, CLASS 5 (MODIFIED) MESIC PRAIRIE	ACRE	2.03			2.03
XX006722	TEMPORARY AGGREGATE BERM-COURSE AGGREGATE	TON	630			630
XX006723	TEMPORARY AGGREGATE BERM-RIPRAP	TON	1,353			1353
● XX007251	INTERSECTION VIDEO TRAFFIC MONITORING SYSTEM WITH PTZ CAMERA	EACH		1		1
Z0001050	AGGREGATE SUBGRADE 12"	SQ YD	67,519			67519
Z0013798	CONSTRUCTION LAYOUT	L SUM	1			1
Z0019600	DUST CONTROL WATERING	UNIT	10			10
Z0048665	RAILROAD PROTECTIVE LIABILITY INSURANCE	L SUM	1			1
Z0064500	SECTION MARKERS	EACH	3			3
Δ Z0076600	TRANEES	hour	4,500			4500
XX007959	PORTLAND CEMENT CONCRETE SHOULDERS, 6" (SPECIAL)	SQ YD	9,176			9176
XX007954	STORM SEWER (WATER MAIN REQUIREMENTS), SPAN 23, RISE 14	FOOT	70			70
XX007963	RESTRICTED DEPTH INLETS, TYPE B, TYPE 11 FRAME AND GRATE	EACH	1			1
B1703060	STEEL COMBINATION MAST ARM ASSEMBLY AND POLE, 65 FT.	EACH		1		1
B1703090	STEEL COMBINATION MAST ARM ASSEMBLY AND POLE, 70 FT.	EACH		3		3
XX007955	CONCRETE FOUNDATION, TYPE E 42-INCH DIAMETER	FOOT		100		100
XX007956	RESTRICTED DEPTH CATCH BASINS, 6'-DIAMETER, TYPE 24 FRAME AND GRATE	EACH	3			3
XX007957	EROSION CONTROL, TEMPORARY CHANNEL DIVERSION	FOOT	700			700
XX007958	DIVERSION STRUCTURE	EACH	1			1
XX007963	ETHERNET HUB KIT	EACH		1		1

Δ Y080

* DENOTES SPECIALTY ITEM

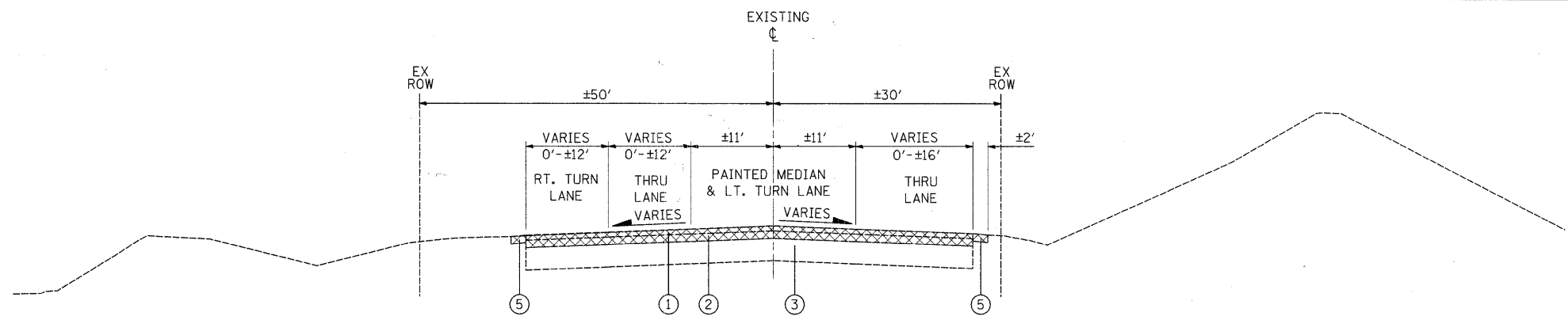

MCDONALD ROAD - EXISTING TYPICAL SECTION
STA. 678+22.7 TO STA. 682+42

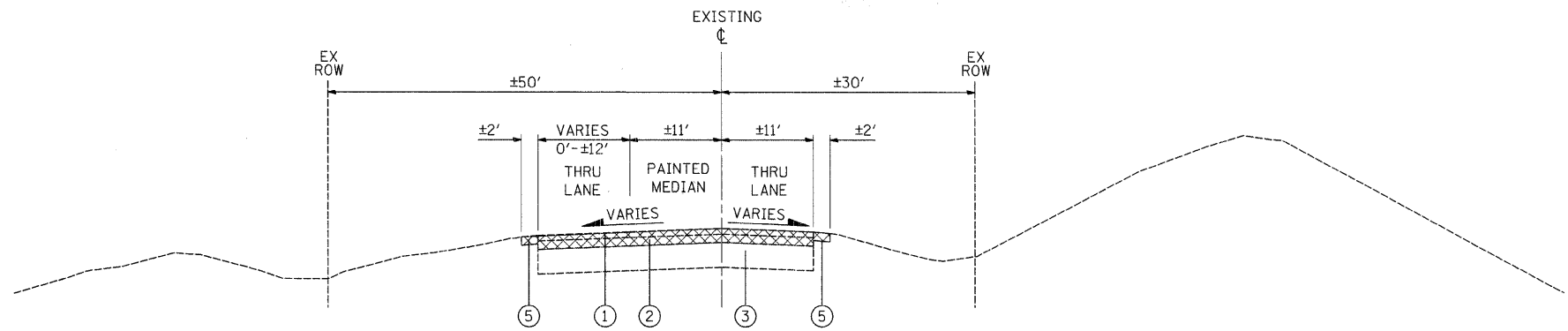

MCDONALD ROAD - EXISTING TYPICAL SECTION
STA. 682+42 TO STA. 689+00

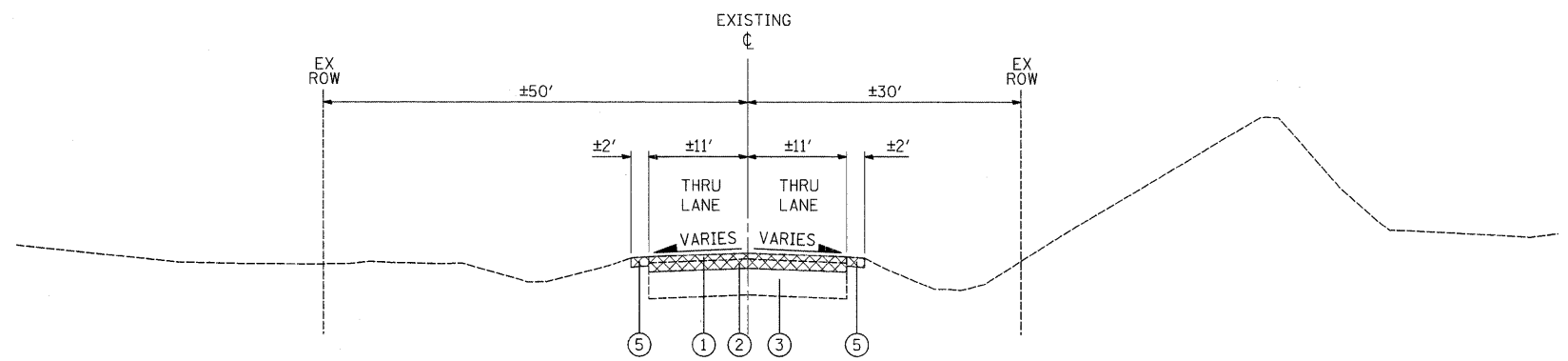

MCDONALD ROAD - EXISTING TYPICAL SECTION
STA. 689+00 TO STA. 702+04
EXISTING

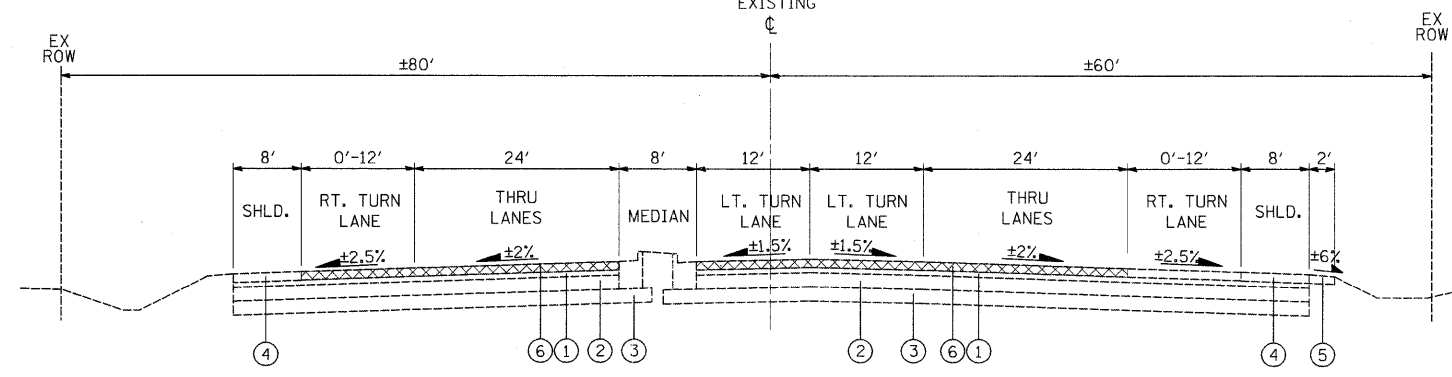

RANDALL ROAD - EXISTING TYPICAL SECTION

LEGEND

- ① HMA PAVEMENT, SURFACE, 1 1/4" TO 4 1/2"
- ② HMA PAVEMENT, BINDER, 1 3/4" TO 8"
- ③ GRANULAR BASE, 5" TO 19"
- ④ HMA SHOULDERS
- ⑤ AGGREGATE SHOULDERS
- ⑥ HOT-MIX ASPHALT SURFACE REMOVAL, 2"



STEARNS ROAD - PCC

STRUCTURAL DESIGN TRAFFIC: YEAR 2020
 PV = 31,450 SU = 170 MU = 2380
 ROAD/STREET CLASSIFICATION: CLASS I
 PERCENT OF STRUCTURE DESIGN TRAFFIC IN DESIGN LANE
 P = 50 S = 50 M = 50
 TRAFFIC FACTOR ACTUAL TF = 2.41
 MINIMUM TF = N/A
 P.C.C. THICKNESS = 10.0 INCHES
 SUBGRADE SUPPORT RATING:
 SSR = POOR

STEARNS ROAD - HMA

STRUCTURAL DESIGN TRAFFIC: YEAR 2020
 PV = 31,450 SU = 170 MU = 2380
 ROAD/STREET CLASSIFICATION: CLASS I
 PERCENT OF STRUCTURE DESIGN TRAFFIC IN DESIGN LANE
 P = 50 S = 50 M = 50
 TRAFFIC FACTOR ACTUAL TF = 2.41
 MINIMUM TF = N/A AC TYPE = AC-78
 PG GRADE: BINDER 8 3/4 INCHES SURFACE = 2 INCHES
 SUBGRADE SUPPORT RATING:
 SSR = POOR

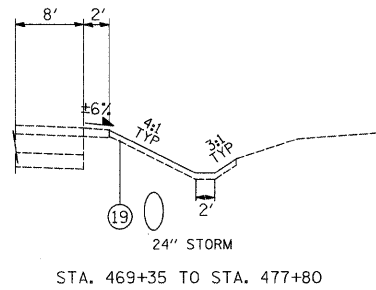

LEGEND

- ① PORTLAND CEMENT CONCRETE PAVEMENT 10" (JOINTED) (42000501)
- ② POLYMERIZED HOT-MIX ASPHALT SURFACE COURSE, MIX "F", N90, 2" (40603595)
- ③ NOT USED
- ④ POLYMERIZED HOT-MIX ASPHALT BINDER COURSE, IL-19.0, N90, 8 3/4" (40701896)
- ⑤ EMBANKMENT
- ⑥ SUB-BASE GRANULAR MATERIAL, TYPE B (31101000)
- ⑦ AGGREGATE SUBGRADE 12" (Z0001050)
- ⑧ PORTLAND CEMENT CONCRETE SHOULDERS 6" (SPECIAL)
- ⑨ CONCRETE MEDIAN, TYPE SB-6.24 (MODIFIED) (60620200)
- ⑩ AGGREGATE SHOULDERS, TYPE B 6" (48101500)
- ⑪ COMBINATION CONCRETE CURB AND GUTTER, TYPE B-6.24 (60605000)
- ⑫ COMBINATION CONCRETE CURB AND GUTTER, TYPE B-6.12 (60603800)
- ⑬ CONCRETE GUTTER, TYPE A (60602500)
- ⑭ CONCRETE MEDIAN, TYPE SB-6.24 (60620000)
- ⑮ #6 BARS (EPOXY COATED) 30" LENGTH, @ 30" CENTERS AT PAVEMENT TO PAVEMENT JOINTS
 #6 BARS (EPOXY COATED) 24" LENGTH, @ 24" CENTERS AT PAVEMENT TO SHOULDER JOINTS
 #6 BARS (EPOXY COATED) 24" LENGTH, @ 24" CENTERS AT PAVEMENT TO C&G/MEDIAN JOINTS (INCIDENTAL TO P.C.C. PAVEMENT)
- ⑯ HMA SHOULDERS 6" (48203021)
- ⑰ STEEL PLATE BEAM GUARD RAIL, TYPE A, 6 FOOT POSTS (63000001)
- ⑱ MECHANICALLY STABILIZED EARTH RETAINING WALL (XX004056)
- ⑲ TOPSOIL FURNISH AND PLACE, 4" (21101615) & SEEDING CLASS 7 (25000350) (SEE LANDSCAPING SHEETS FOR LIMITS OF SEEDING)
- ⑳ TOPSOIL FURNISH AND PLACE, 24" (21101685) & SEEDING CLASS 7 (25000350)

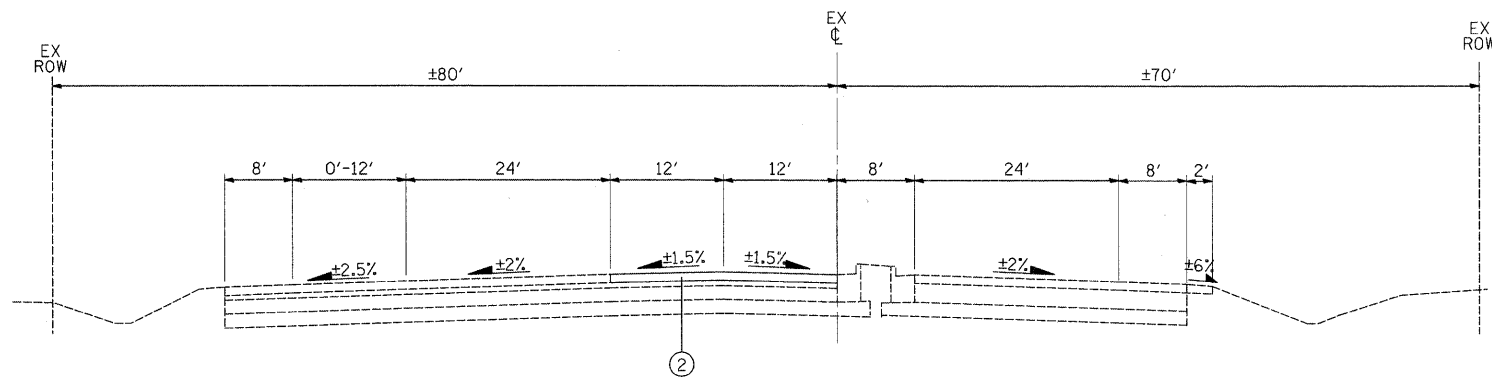

RANDALL ROAD PROPOSED TYPICAL SECTION
 STA. 480+55 TO STA. 486+75.5

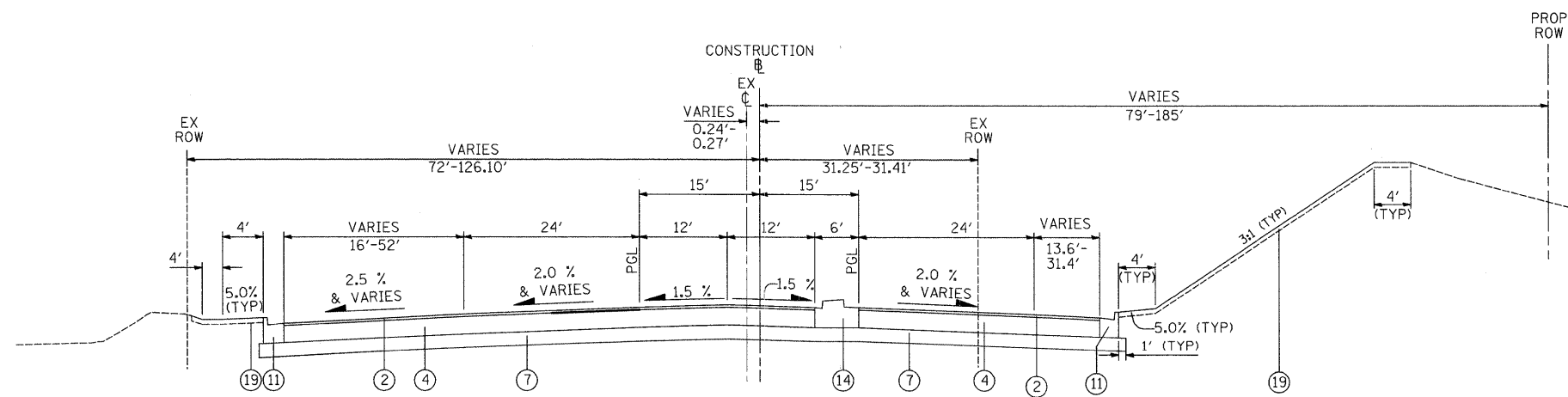

STEARNS ROAD PROPOSED TYPICAL SECTION
 STA. 436+15.8 TO STA. 437+50

*PAID FOR AS HOT-MIX ASPHALT PAVEMENT (FULL DEPTH), 10 3/4" (40701896)

HOT-MIX ASPHALT MIXTURE REQUIREMENTS		
MIXTURE TYPE	AC TYPE	VOIDS
HOT-MIX ASPHALT RESURFACING (RANDALL ROAD AND McDONALD ROAD)		
POLYMERIZED HOT-MIX ASPHALT SURFACE COURSE, MIX "F", N90, 2"	SBS/SBR PG 70-22	4% @ 90 GYR.
PROPOSED WIDENING AND RECONSTRUCTION (STEARNS RD AND McDONALD ROAD) FULL DEPTH PAVEMENT		
POLYMERIZED HOT-MIX ASPHALT SURFACE COURSE, MIX "F", N90, 2"	SBS/SBR PG 70-22	4% @ 90 GYR.
POLYMERIZED HOT-MIX ASPHALT BINDER COURSE, IL-19.0, N90, 8-3/4"	SBS/SBR PG 70-22	4% @ 90 GYR.
SHOULDERS		
HOT-MIX ASPHALT SHOULDER, 6"	PG 64-22*	2% @ 30 GYR.
DRIVEWAY (COMMERCIAL DRIVEWAYS)		
HOT-MIX ASPHALT SURFACE COURSE, MIX "C", N50, 2"	PG 64-22	4% @ 50 GYR.
HOT-MIX ASPHALT BASE COURSE (HMA BINDER, IL-19 MM), 8"	PG 64-22	4% @ 50 GYR.
TEMPORARY PAVEMENT		
TEMPORARY PAVEMENT 8"	PG 64-22	4% @ 50 Gyr.
PATCHING		
CLASS D PATCHES, TYPE IV, 12 INCH	PG 64-22*	4% @ 70 Gyr.

* WHEN RAP EXCEEDS 20%, THE NEW ASPHALT BINDER IN THE MIX SHALL BE PG 58-22.

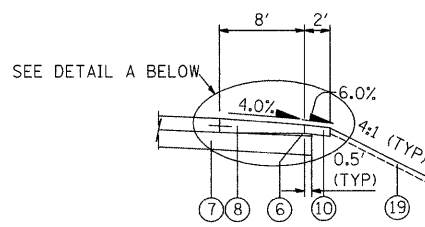
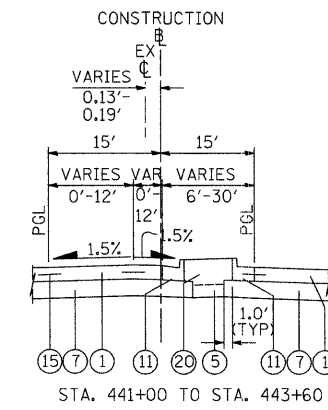
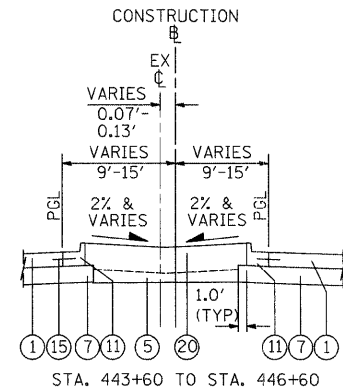
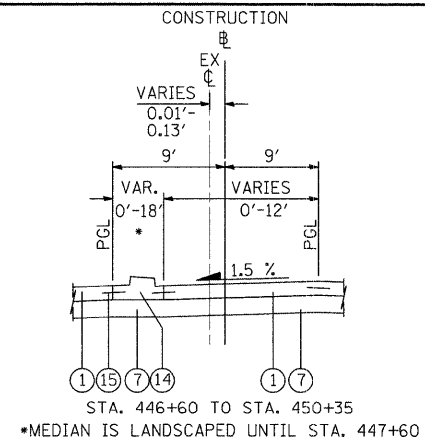

LEGEND

- ① PORTLAND CEMENT CONCRETE PAVEMENT 10" (JOINTED) (42000501)
- ② POLYMERIZED HOT-MIX ASPHALT SURFACE COURSE, MIX "F", N90, 2" (40603595)
- ③ NOT USED
- ④ POLYMERIZED HOT-MIX ASPHALT BINDER COURSE, IL-19.0, N90, 8 3/4" (40701896)
- ⑤ EMBANKMENT
- ⑥ SUB-BASE GRANULAR MATERIAL, TYPE B (31101000)
- ⑦ AGGREGATE SUBGRADE 12" (20001050)
- ⑧ PORTLAND CEMENT CONCRETE SHOULDERS 6" (SPECIAL)
- ⑨ CONCRETE MEDIAN, TYPE SB-6.24 (MODIFIED) (60620200)
- ⑩ AGGREGATE SHOULDERS, TYPE B 6" (48101500)
- ⑪ COMBINATION CONCRETE CURB AND GUTTER, TYPE B-6.24 (60605000)
- ⑫ COMBINATION CONCRETE CURB AND GUTTER, TYPE B-6.12 (60603800)
- ⑬ CONCRETE GUTTER, TYPE A (60602500)
- ⑭ CONCRETE MEDIAN, TYPE SB-6.24 (60620000)
- ⑮ #6 BARS (EPOXY COATED) 30" LENGTH, @ 30" CENTERS AT PAVEMENT TO PAVEMENT JOINTS
 #6 BARS (EPOXY COATED) 24" LENGTH, @ 24" CENTERS AT PAVEMENT TO SHOULDER JOINTS
 #6 BARS (EPOXY COATED) 24" LENGTH, @ 24" CENTERS AT PAVEMENT TO C&G/MEDIAN JOINTS (INCIDENTAL TO P.C.C. PAVEMENT)
- ⑯ HMA SHOULDERS 6" (48203021)
- ⑰ STEEL PLATE BEAM GUARD RAIL, TYPE A, 6 FOOT POSTS (63000001)
- ⑱ MECHANICALLY STABILIZED EARTH RETAINING WALL (XX004056)
- ⑲ TOPSOIL FURNISH AND PLACE, 4" (21101615) & SEEDING CLASS 7 (25000350) (SEE LANDSCAPING SHEETS FOR LIMITS OF SEEDING)
- ⑳ TOPSOIL FURNISH AND PLACE, 24" (21101685) & SEEDING CLASS 7 (25000350)

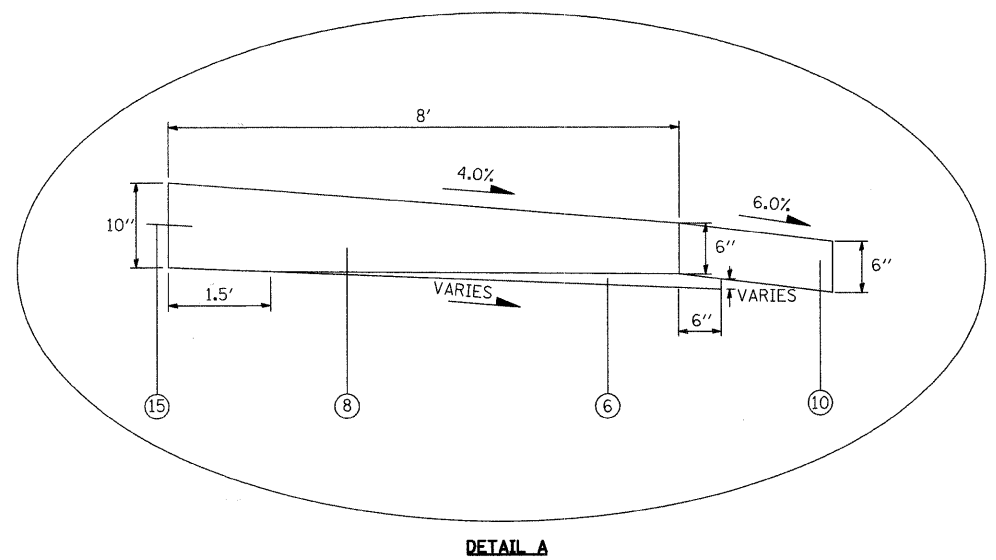
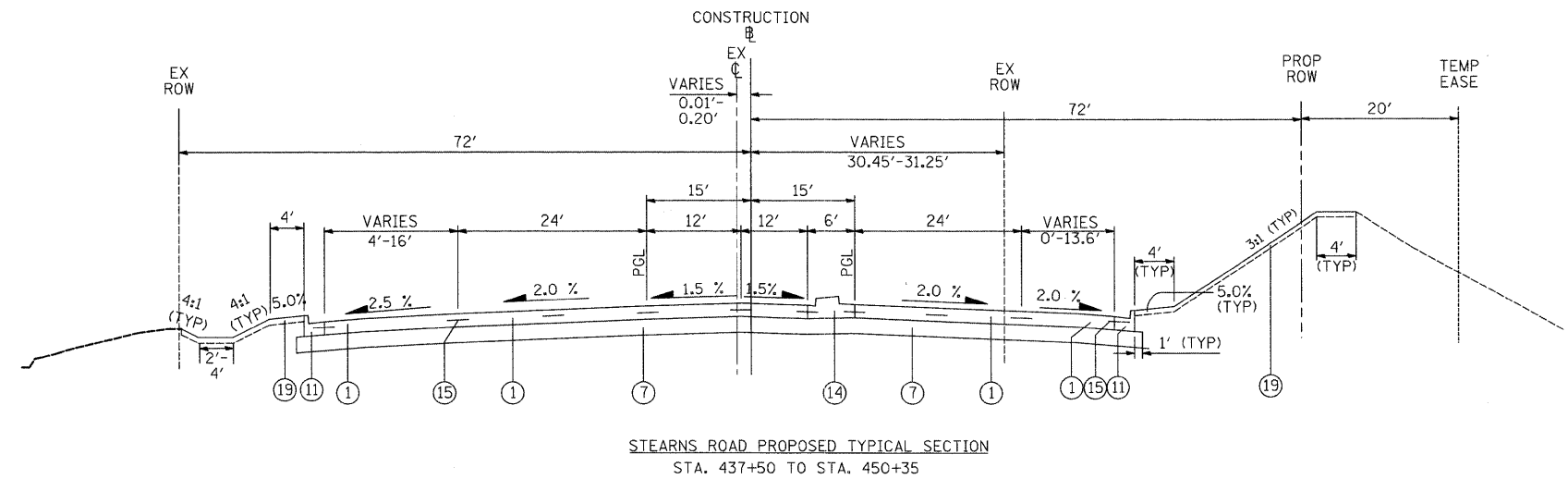
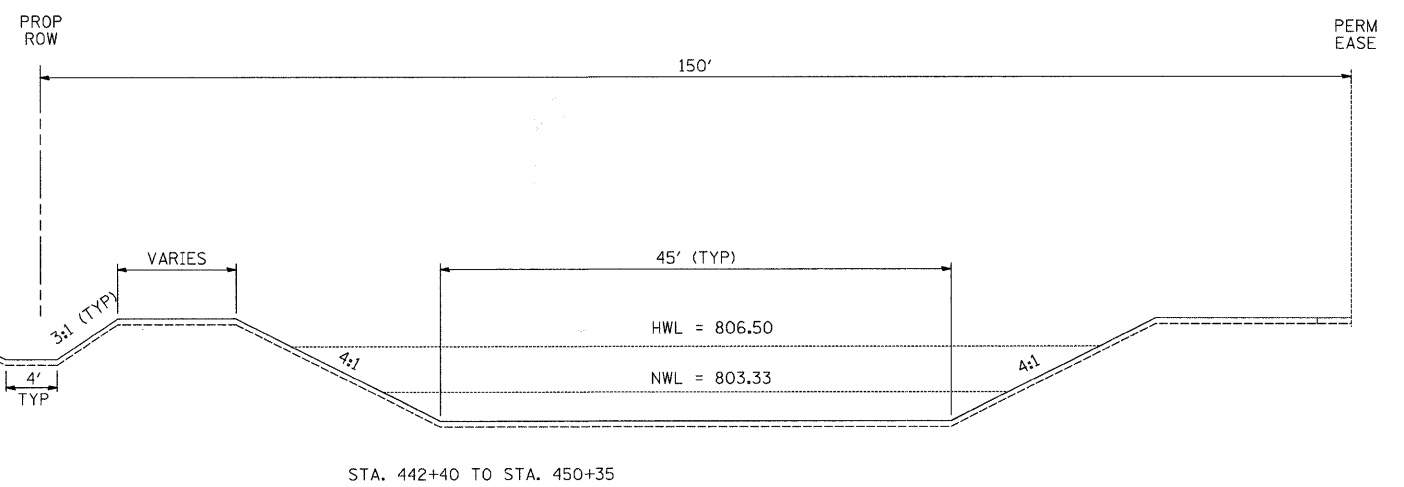

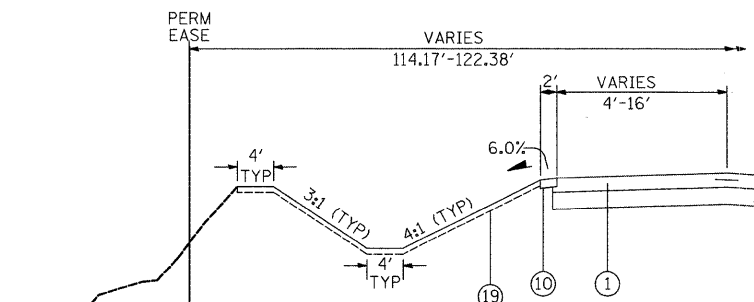

STA. 459+09 TO STA. 463+89
 *PERM EASE STA. 461+36 TO STA. 462+62

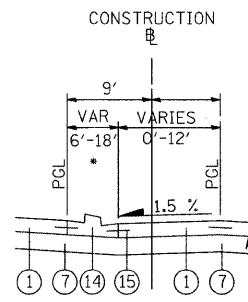

STA. 452+80 TO STA. 454+13
 *MEDIAN IS LANDSCAPED STA. 452+80 TO STA. 454+13

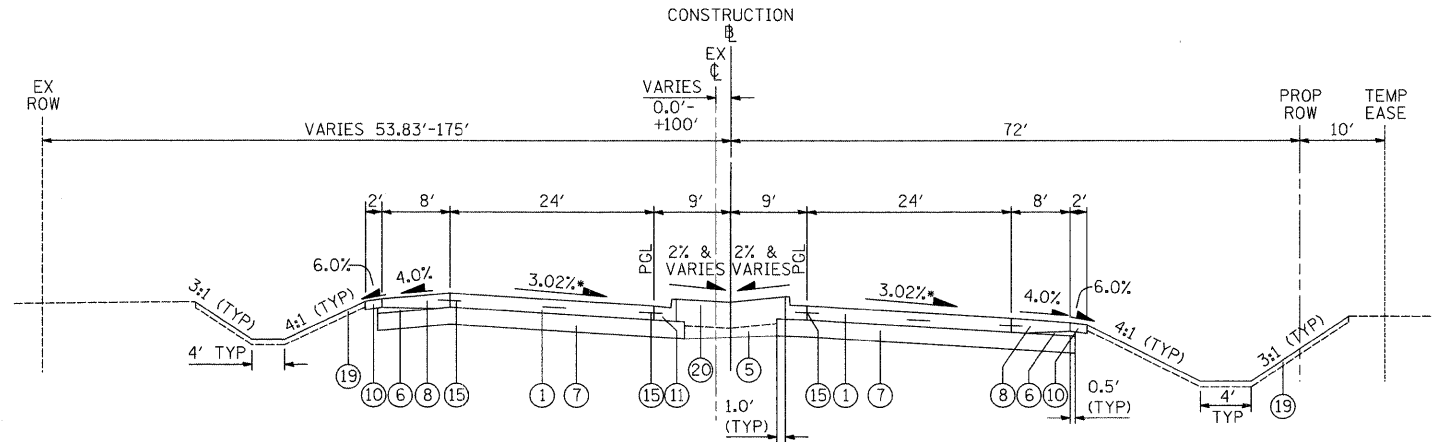

STEARNS ROAD PROPOSED TYPICAL SECTION
 STA. 450+35 TO STA. 466+85
 + SEE SUPERELEVATION TABLE FOR RATES & LOCATIONS

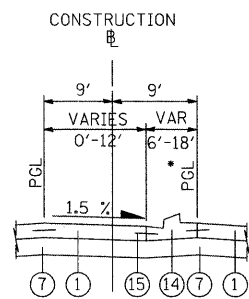

STA. 476+00 TO STA. 479+95
 *MEDIAN IS LANDSCAPED STA. 478+40 TO STA. 479+95

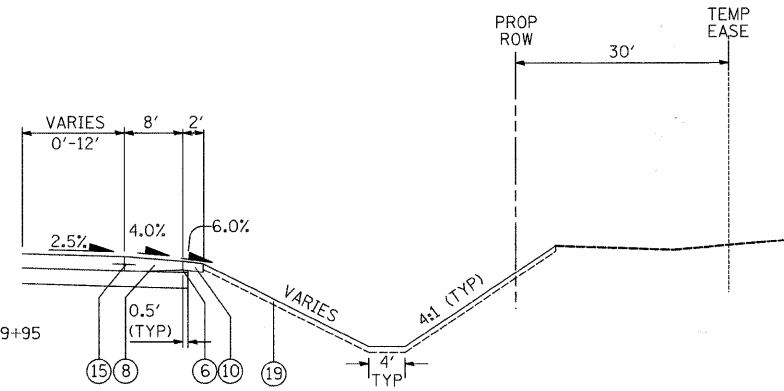

STA. 471+45 TO STA. 475+20

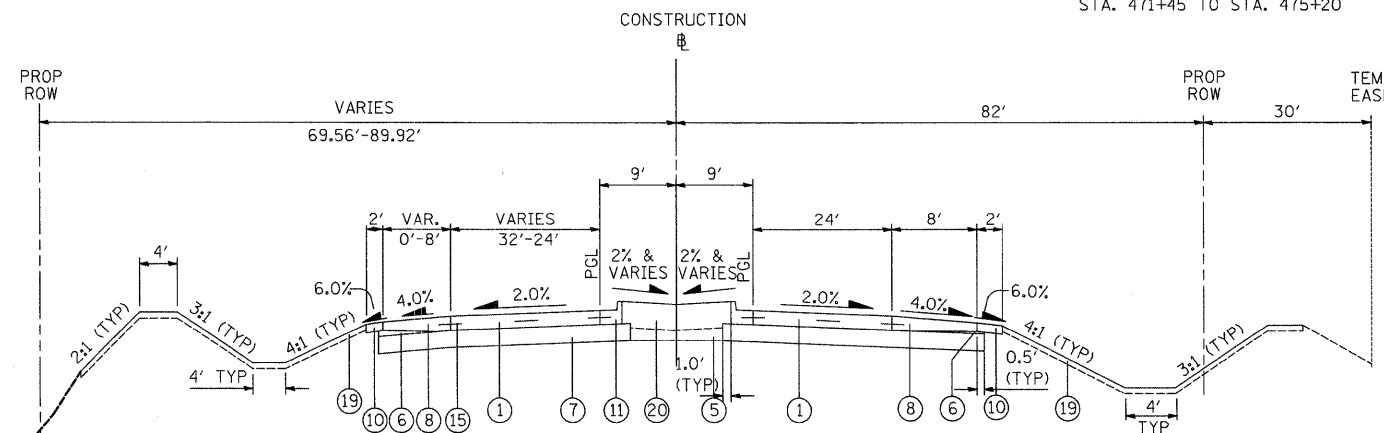

STEARNS ROAD PROPOSED TYPICAL SECTION
 STA. 466+85 TO STA. 480+55

LEGEND

- ① PORTLAND CEMENT CONCRETE PAVEMENT 10" (JOINTED) (42000501)
- ② POLYMERIZED HOT-MIX ASPHALT SURFACE COURSE, MIX "F", N90, 2" (40603595)
- ③ NOT USED
- ④ POLYMERIZED HOT-MIX ASPHALT BINDER COURSE, IL-19.0, N90, 8 3/4" (40701896)
- ⑤ EMBANKMENT
- ⑥ SUB-BASE GRANULAR MATERIAL, TYPE B (31101900)
- ⑦ AGGREGATE SUBGRADE 12" (20001050)
- ⑧ PORTLAND CEMENT CONCRETE SHOULDERS 6" (SPECIAL)
- ⑨ CONCRETE MEDIAN, TYPE SB-6.24 (MODIFIED) (60620200)
- ⑩ AGGREGATE SHOULDERS, TYPE B 6" (48101500)
- ⑪ COMBINATION CONCRETE CURB AND GUTTER, TYPE B-6.24 (60605000)
- ⑫ COMBINATION CONCRETE CURB AND GUTTER, TYPE B-6.12 (60603800)
- ⑬ CONCRETE GUTTER, TYPE A (60602500)
- ⑭ CONCRETE MEDIAN, TYPE SB-6.24 (60620000)
- ⑮ #6 BARS (EPOXY COATED) 30" LENGTH, @ 30" CENTERS AT PAVEMENT TO PAVEMENT JOINTS
 #6 BARS (EPOXY COATED) 24" LENGTH, @ 24" CENTERS AT PAVEMENT TO SHOULDER JOINTS
 #6 BARS (EPOXY COATED) 24" LENGTH, @ 24" CENTERS AT PAVEMENT TO C&G/MEDIAN JOINTS (INCIDENTAL TO P.C.C. PAVEMENT)
- ⑯ HMA SHOULDERS 6" (48203021)
- ⑰ STEEL PLATE BEAM GUARD RAIL, TYPE A, 6 FOOT POSTS (63000001)
- ⑱ MECHANICALLY STABILIZED EARTH RETAINING WALL (XX004056)
- ⑲ TOPSOIL FURNISH AND PLACE, 4" (21101615) & SEEDING CLASS 7 (25000350) (SEE LANDSCAPING SHEETS FOR LIMITS OF SEEDING)
- ⑳ TOPSOIL FURNISH AND PLACE, 24" (21101685) & SEEDING CLASS 7 (25000350)

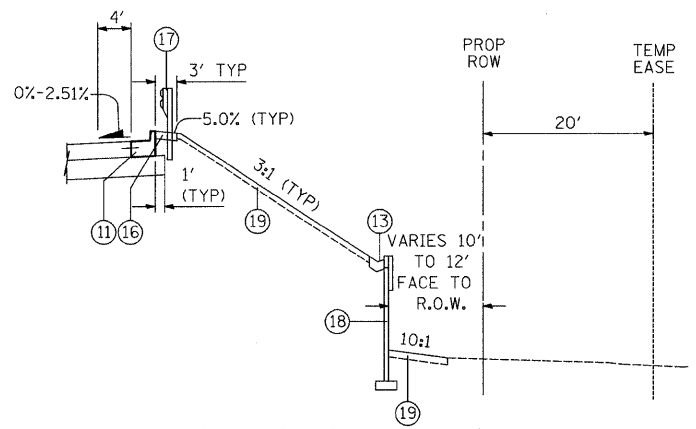

STA. 499+20 TO STA. 501+85

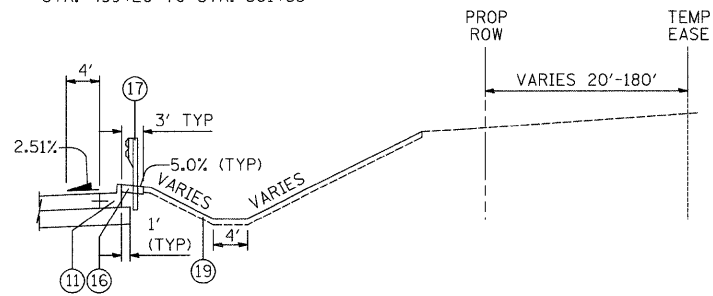

STA. 498+50 TO STA. 499+20

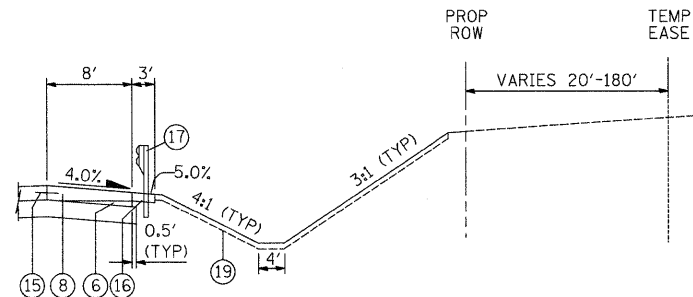

STA. 496+00 TO STA. 498+50

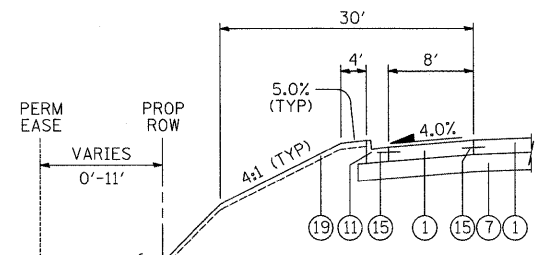

STA. 483+39 TO STA. 489+25

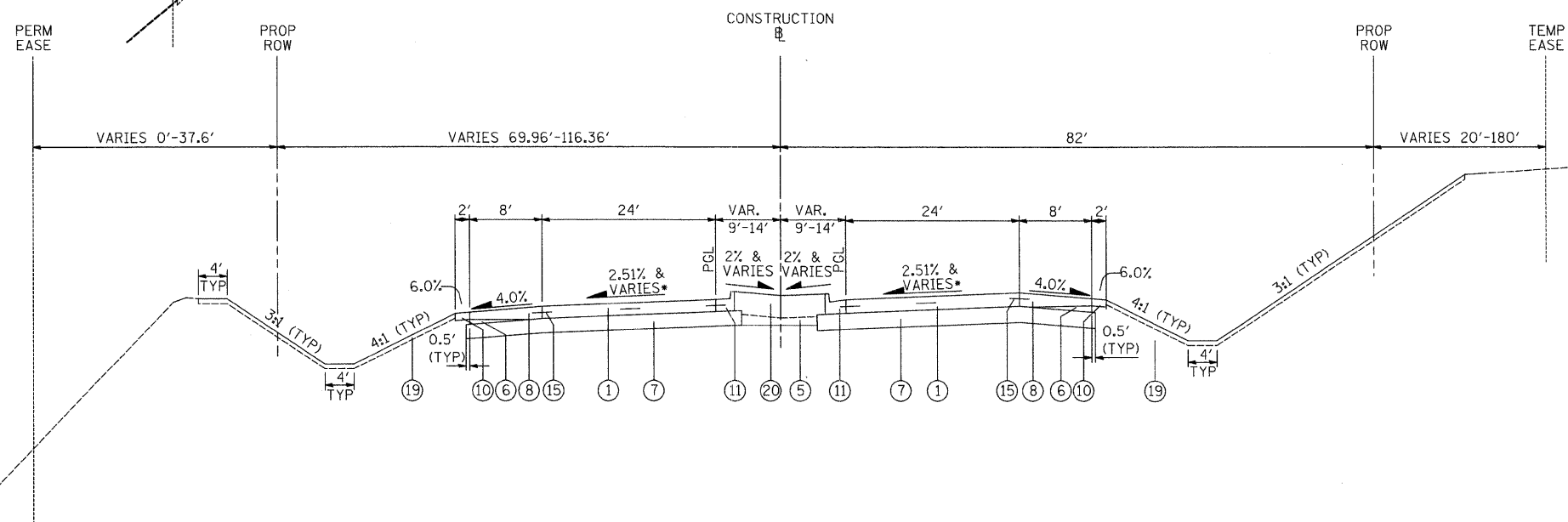

STEARNS ROAD PROPOSED TYPICAL SECTION
STA. 480+55 TO STA. 501+85

LEGEND

- ① PORTLAND CEMENT CONCRETE PAVEMENT 10" (JOINTED) (42000501)
- ② POLYMERIZED HOT-MIX ASPHALT SURFACE COURSE, MIX "F", N90, 2" (40603595)
- ③ NOT USED
- ④ POLYMERIZED HOT-MIX ASPHALT BINDER COURSE, IL-19.0, N90, 8 3/4" (40701896)
- ⑤ EMBANKMENT
- ⑥ SUB-BASE GRANULAR MATERIAL, TYPE B (31101000)
- ⑦ AGGREGATE SUBGRADE 12" (Z0001050)
- ⑧ PORTLAND CEMENT CONCRETE SHOULDERS 6" (SPECIAL)
- ⑨ CONCRETE MEDIAN, TYPE SB-6.24 (MODIFIED) (60620200)
- ⑩ AGGREGATE SHOULDERS, TYPE B 6" (48101500)
- ⑪ COMBINATION CONCRETE CURB AND GUTTER, TYPE B-6.24 (60605000)
- ⑫ COMBINATION CONCRETE CURB AND GUTTER, TYPE B-6.12 (60603800)
- ⑬ CONCRETE GUTTER, TYPE A (60602500)
- ⑭ CONCRETE MEDIAN, TYPE SB-6.24 (60620000)
- ⑮ #6 BARS (EPOXY COATED) 30" LENGTH, @ 30" CENTERS AT PAVEMENT TO PAVEMENT JOINTS
#6 BARS (EPOXY COATED) 24" LENGTH, @ 24" CENTERS AT PAVEMENT TO SHOULDER JOINTS
#6 BARS (EPOXY COATED) 24" LENGTH, @ 24" CENTERS AT PAVEMENT TO C&G/MEDIAN JOINTS
(INCIDENTAL TO P.C.C. PAVEMENT)
- ⑯ HMA SHOULDERS 6" (48203021)
- ⑰ STEEL PLATE BEAM GUARD RAIL, TYPE A, 6 FOOT POSTS (63000001)
- ⑱ MECHANICALLY STABILIZED EARTH RETAINING WALL (XX004056)
- ⑲ TOPSOIL FURNISH AND PLACE, 4" (21101615) & SEEDING CLASS 7 (25000350)
(SEE LANDSCAPING SHEETS FOR LIMITS OF SEEDING)
- ⑳ TOPSOIL FURNISH AND PLACE, 24" (21101685) & SEEDING CLASS 7 (25000350)

FILE NAME =

USER NAME = ead
 PLOT SCALE = 1:8000" / IN.
 PLOT DATE = 4/16/2009

DESIGNED - JSM
 DRAWN - JSM
 CHECKED - DNM
 DATE - 3/30/09

REVISED -
 REVISED -
 REVISED -
 REVISED -

**KANE COUNTY
 DIVISION OF TRANSPORTATION**

**PROPOSED TYPICAL SECTIONS -
 STEARNS ROAD**
 SCALE: N.T.S. SHEET NO. 5 OF 6 SHEETS STA. 480+00 TO STA. 508+40

F.A. RTE. 361	SECTION 06-00214-25-BR	COUNTY KANE	TOTAL SHEETS 220	SHEET NO. 10
CONTRACT NO. 63076				
FED. ROAD DIST. NO. 1 ILLINOIS FED. AID PROJECT				

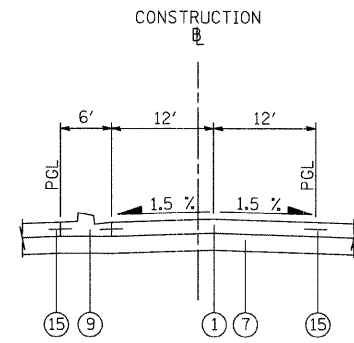

STA. 504+87 TO STA. 508+40

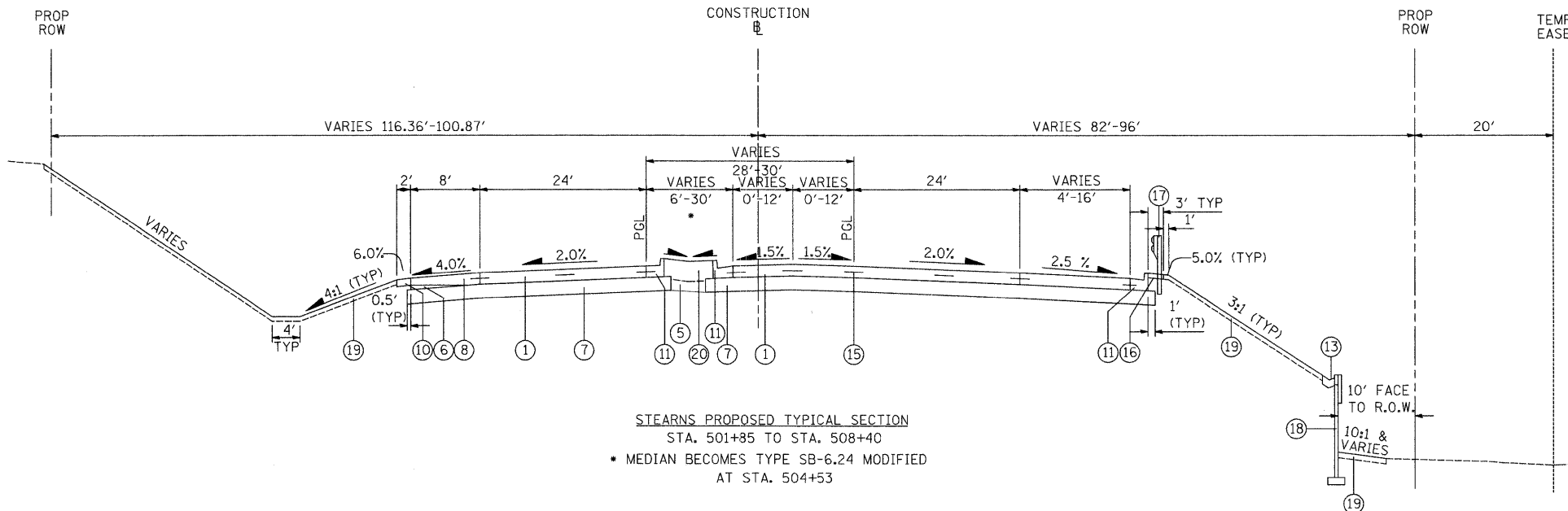

STEARNS PROPOSED TYPICAL SECTION
STA. 501+85 TO STA. 508+40
• MEDIAN BECOMES TYPE SB-6.24 MODIFIED
AT STA. 504+53

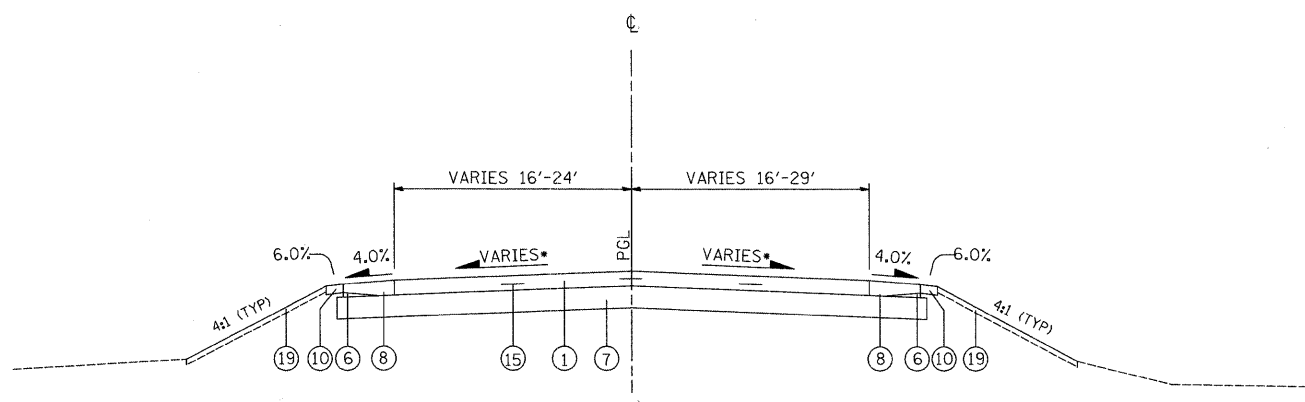

UMBDENSTOCK ROAD PROPOSED TYPICAL SECTION
STA. 700+34.67 TO STA. 702+51

• ROADWAY SUPERELEVATED, SEE SUPERELEVATION TABLE FOR RATES & LOCATIONS

LEGEND

- ① PORTLAND CEMENT CONCRETE PAVEMENT 10" (JOINTED) (42000501)
- ② POLYMERIZED HOT-MIX ASPHALT SURFACE COURSE, MIX "F", N90, 2" (40603595)
- ③ NOT USED
- ④ POLYMERIZED HOT-MIX ASPHALT BINDER COURSE, IL-19.0, N90, 8 3/4" (40701896)
- ⑤ EMBANKMENT
- ⑥ SUB-BASE GRANULAR MATERIAL, TYPE B (31101000)
- ⑦ AGGREGATE SUBGRADE 12" (Z0001050)
- ⑧ PORTLAND CEMENT CONCRETE SHOULDERS 6" (SPECIAL)
- ⑨ CONCRETE MEDIAN, TYPE SB-6.24 (MODIFIED) (60620200)
- ⑩ AGGREGATE SHOULDERS, TYPE B 6" (48101500)
- ⑪ COMBINATION CONCRETE CURB AND GUTTER, TYPE B-6.24 (60605000)
- ⑫ COMBINATION CONCRETE CURB AND GUTTER, TYPE B-6.12 (60603800)
- ⑬ CONCRETE GUTTER, TYPE A (60602500)
- ⑭ CONCRETE MEDIAN, TYPE SB-6.24 (60620000)
- ⑮ #6 BARS (EPOXY COATED) 30" LENGTH, @ 30" CENTERS AT PAVEMENT TO PAVEMENT JOINTS
#6 BARS (EPOXY COATED) 24" LENGTH, @ 24" CENTERS AT PAVEMENT TO SHOULDER JOINTS
#6 BARS (EPOXY COATED) 24" LENGTH, @ 24" CENTERS AT PAVEMENT TO C&G/MEDIAN JOINTS
(INCIDENTAL TO P.C.C. PAVEMENT)
- ⑯ HMA SHOULDERS 6" (48203021)
- ⑰ STEEL PLATE BEAM GUARD RAIL, TYPE A, 6 FOOT POSTS (63000001)
- ⑱ MECHANICALLY STABILIZED EARTH RETAINING WALL (XX004056)
- ⑲ TOPSOIL FURNISH AND PLACE, 4" (21101615) & SEEDING CLASS 7 (25000350) (SEE LANDSCAPING SHEETS FOR LIMITS OF SEEDING)
- ⑳ TOPSOIL FURNISH AND PLACE, 24" (21101685) & SEEDING CLASS 7 (25000350)

UMBDENSTOCK ROAD - PCC

STRUCTURAL DESIGN TRAFFIC:	YEAR 2020	
PV = 11,100	SU = 60	MU = 840
ROAD/STREET CLASSIFICATION: CLASS I		
PERCENT OF STRUCTURE DESIGN TRAFFIC IN DESIGN LANE		
P = 50	S = 50	M = 50
TRAFFIC FACTOR	ACTUAL TF = 0.6	
	MINIMUM TF = N/A	
P.C.C. THICKNESS = 10.0 INCHES		
SUBGRADE SUPPORT RATING:		
SSR = POOR		



FILE NAME =	USER NAME = ead	DESIGNED - JSM	REVISED -
		DRAWN - JSM	REVISED -
		CHECKED - DNM	REVISED -
		DATE - 3/30/09	REVISED -

**KANE COUNTY
DIVISION OF TRANSPORTATION**

**PROPOSED TYPICAL SECTIONS - STEARNS ROAD &
UMBDENSTOCK ROAD**

F.A. RTE.	SECTION	COUNTY	TOTAL SHEETS	SHEET NO.
361	06-00214-25-BR	KANE	220	11
CONTRACT NO. 63076				

STEARNS ROAD - EARTHWORK CALCULATIONS

STATION	DISTANCE	STAGE 1 EARTH EXCAVATION	STAGE 2 EARTH EXCAVATION	STAGE 3 EARTH EXCAVATION	STAGE 1 EARTH EXCAVATION (ADJ. FOR SHRINKAGE)	STAGE 2 EARTH EXCAVATION (ADJ. FOR SHRINKAGE)	STAGE 3 EARTH EXCAVATION (ADJ. FOR SHRINKAGE)	STAGE 1 EMBNAKMENT	STAGE 2 EMBNAKMENT	STAGE 3 EMBNAKMENT	STAGE 1 EARTHWORK BALANCE WASTE (+) OR SHORTAGE (-)	STAGE 2 EARTHWORK BALANCE WASTE (+) OR SHORTAGE (-)	STAGE 3 EARTHWORK BALANCE WASTE (+) OR SHORTAGE (-)
(XXX+XX)	(FT.)	(CU. YD.)	(CU. YD.)	(CU. YD.)	(CU. YD.)	(CU. YD.)	(CU. YD.)	(CU. YD.)	(CU. YD.)	(CU. YD.)	(CU. YD.)	(CU. YD.)	(CU. YD.)
STEARNS ROAD													
436+50	50	0.0	435.0	233.1	0.0	369.7	198.1	0.0	0.0	0.6	0.0	369.7	197.5
437+00	50	0.0	518.6	279.3	0.0	440.8	237.4	0.0	0.0	0.7	0.0	440.8	236.7
437+50	50	0.0	530.4	279.8	0.0	450.8	237.8	0.0	0.0	1.7	0.0	450.8	236.1
438+00	50	0.0	510.4	253.2	0.0	433.9	215.2	0.0	0.0	5.2	0.0	433.9	210.1
438+50	50	0.0	415.5	212.3	0.0	353.1	180.4	0.0	0.0	11.1	0.0	353.1	169.3
439+00	50	0.0	350.3	178.6	0.0	297.8	151.8	0.0	0.0	7.6	0.0	297.8	144.3
439+50	50	0.0	328.1	167.3	0.0	278.9	142.2	0.0	0.0	0.0	0.0	278.9	142.2
440+00	50	0.0	269.8	144.8	0.0	229.3	123.1	0.0	0.0	5.6	0.0	229.3	117.4
440+50	50	0.0	245.2	129.1	0.0	208.4	109.7	0.0	0.0	10.7	0.0	208.4	99.0
441+00	50	0.0	227.3	134.0	0.0	193.2	113.9	0.0	0.9	11.8	0.0	193.2	102.1
441+50	50	0.0	182.3	132.9	0.0	155.0	113.0	0.0	1.8	22.8	0.0	155.0	90.2
442+00	50	0.0	285.2	148.3	0.0	242.4	126.1	1260.8	8.1	16.0	-1260.8	234.3	110.0
442+50	50	90.7	430.7	134.6	77.1	366.1	114.4	1898.2	14.6	4.6	-1821.1	351.5	109.9
443+00	50	221.5	518.1	118.4	188.3	440.3	100.6	1028.4	7.4	10.1	-840.1	433.0	90.6
443+50	50	305.6	552.9	139.6	259.8	470.0	118.7	657.5	1.5	17.7	-397.7	468.5	101.0
444+00	50	544.7	611.2	148.9	463.0	519.5	126.6	292.8	1.5	24.2	170.2	518.1	102.4
444+50	50	809.0	556.9	156.9	687.7	473.4	133.4	188.0	0.0	23.0	499.7	473.4	110.4
445+00	50	912.4	409.4	168.3	775.5	348.0	143.0	280.6	0.0	20.4	494.9	348.0	122.7
445+50	50	929.5	376.8	172.4	790.1	320.3	146.6	231.4	0.0	12.3	558.7	320.3	134.3
446+00	50	878.9	495.4	137.6	747.1	421.1	117.0	234.5	1.6	19.3	512.6	419.5	97.7
446+50	50	863.4	624.5	107.7	733.9	530.8	91.5	258.4	2.4	33.0	475.5	528.4	58.6
447+00	50	959.0	614.0	120.4	815.1	521.9	102.3	266.4	1.1	27.1	548.7	520.8	75.2
447+50	50	1108.3	589.2	125.0	942.1	500.8	106.2	240.1	0.4	21.2	702.0	500.4	85.0
448+00	50	1101.7	570.2	114.7	936.4	484.7	97.5	218.7	1.4	18.3	717.7	483.3	79.2
448+50	50	1014.8	591.3	135.6	862.6	502.6	115.2	247.8	4.8	11.0	614.8	497.8	104.3
449+00	50	1004.7	612.7	173.0	854.0	520.8	147.1	266.2	7.5	7.1	587.8	513.4	139.9
449+50	50	993.0	621.0	163.9	844.1	527.8	139.4	267.4	7.5	3.9	576.6	520.3	135.4
450+00	50	491.6	594.7	159.0	417.8	505.5	135.2	140.3	6.0	0.0	277.6	499.5	135.2
450+50	50	0.0	519.7	188.0	0.0	441.7	159.8	0.0	2.5	0.5	0.0	439.3	159.3
451+00	50	0.0	458.4	213.7	0.0	389.7	181.7	0.0	2.8	2.7	0.0	386.8	178.9
451+50	50	0.0	446.2	188.1	0.0	379.3	159.9	0.0	4.0	3.5	0.0	375.3	156.4
452+00	50	0.0	457.4	158.8	0.0	388.8	135.0	0.0	2.0	5.8	0.0	386.8	129.2
452+50	50	0.0	437.0	184.5	0.0	371.5	156.9	0.0	4.4	6.7	0.0	367.0	150.2
453+00	50	0.0	383.7	195.5	0.0	326.1	166.1	0.0	8.5	4.4	0.0	317.6	161.7
453+50	50	0.0	392.7	170.1	0.0	333.8	144.6	0.0	7.2	8.9	0.0	326.7	135.7
454+00	50	0.0	437.0	136.1	0.0	371.5	115.7	0.0	2.3	14.5	0.0	369.1	101.2
454+50	50	0.0	455.7	107.1	0.0	387.3	91.0	0.0	3.8	10.9	0.0	383.5	80.1
455+00	50	0.0	452.1	97.3	0.0	384.2	82.7	0.0	3.8	4.2	0.0	380.4	78.5
455+50	50	0.0	378.3	85.8	0.0	321.5	72.9	0.0	0.7	5.1	0.0	320.8	67.8
456+00	50	0.0	353.6	66.9	0.0	300.6	56.8	0.0	20.2	3.9	0.0	280.3	53.0
456+50													

STEARNS ROAD - EARTHWORK CALCULATIONS

STATION	DISTANCE	STAGE 1 EARTH EXCAVATION	STAGE 2 EARTH EXCAVATION	STAGE 3 EARTH EXCAVATION	STAGE 1 EARTH EXCAVATION (ADJ. FOR SHRINKAGE)	STAGE 2 EARTH EXCAVATION (ADJ. FOR SHRINKAGE)	STAGE 3 EARTH EXCAVATION (ADJ. FOR SHRINKAGE)	STAGE 1 EMBNAKMENT	STAGE 2 EMBNAKMENT	STAGE 3 EMBNAKMENT	STAGE 1 EARTHWORK BALANCE WASTE (+) OR SHORTAGE (-)	STAGE 2 EARTHWORK BALANCE WASTE (+) OR SHORTAGE (-)	STAGE 3 EARTHWORK BALANCE WASTE (+) OR SHORTAGE (-)
(XXX+XX)	(FT.)	(CU. YD.)	(CU. YD.)	(CU. YD.)	(CU. YD.)	(CU. YD.)	(CU. YD.)	(CU. YD.)	(CU. YD.)	(CU. YD.)	(CU. YD.)	(CU. YD.)	(CU. YD.)
STEARNS ROAD													
456+50	50	0.0	486.2	39.7	0.0	413.3	33.7	0.0	38.1	0.0	0.0	375.2	33.7
457+00	50	0.0	555.1	8.9	0.0	471.8	7.6	0.0	47.1	0.0	0.0	424.7	7.6
457+50	50	0.0	341.3	0.0	0.0	290.1	0.0	0.0	44.3	0.0	0.0	245.8	0.0
458+00	50	0.0	121.9	0.0	0.0	103.6	0.0	0.0	127.8	0.0	0.0	-24.2	0.0
458+50	50	0.0	78.7	0.7	0.0	66.9	0.6	0.0	480.8	0.0	0.0	-413.9	0.6
459+00	50	0.0	113.9	0.7	0.0	96.8	0.6	0.0	792.0	0.0	0.0	-695.2	0.6
459+50	50	0.0	122.1	0.0	0.0	103.8	0.0	0.0	915.3	0.0	0.0	-811.5	0.0
460+00	50	8.4	45.0	0.0	7.2	38.2	0.0	624.6	491.9	0.0	-617.4	-453.7	0.0
460+50	50	13.4	0.0	0.0	11.4	0.0	0.0	1245.4	0.0	0.0	-1234.0	0.0	0.0
461+00	50	7.7	0.0	0.0	6.6	0.0	0.0	1474.0	0.0	0.0	-1467.4	0.0	0.0
461+50	50	5.1	0.0	0.0	4.3	0.0	0.0	1722.3	0.0	0.0	-1718.0	0.0	0.0
462+00	50	5.0	0.0	0.0	4.2	0.0	0.0	1763.6	0.0	0.0	-1759.4	0.0	0.0
462+50	50	6.1	0.0	0.0	5.2	0.0	0.0	1775.7	0.0	0.0	-1770.5	0.0	0.0
463+00	50	6.3	0.0	0.0	5.4	0.0	0.0	1743.8	0.0	0.0	-1738.5	0.0	0.0
463+50	50	4.8	0.0	0.0	4.0	0.0	0.0	1789.0	0.0	0.0	-1785.0	0.0	0.0
464+00	50	7.3	0.0	0.0	6.2	0.0	0.0	1829.9	0.0	0.0	-1823.7	0.0	0.0
464+50	50	18.6	0.0	0.0	15.8	0.0	0.0	1743.3	0.0	0.0	-1727.5	0.0	0.0
465+00	50	35.9	0.0	0.0	30.5	0.0	0.0	1607.9	0.0	0.0	-1577.4	0.0	0.0
465+50	50	62.7	0.0	0.0	53.3	0.0	0.0	1450.6	0.0	0.0	-1397.3	0.0	0.0
466+00	50	118.2	0.0	0.0	100.5	0.0	0.0	1271.6	0.0	0.0	-1171.1	0.0	0.0
466+50	50	213.1	0.0	0.0	181.1	0.0	0.0	1107.5	0.0	0.0	-925.4	0.0	0.0
467+00	50	212.8	0.0	0.0	180.9	0.0	0.0	1034.5	0.0	0.0	-853.6	0.0	0.0
467+50	50	151.7	0.0	0.0	129.0	0.0	0.0	1046.8	0.0	0.0	-917.8	0.0	0.0
468+00	50	147.8	0.0	0.0	125.7	0.0	0.0	995.1	0.0	0.0	-869.4	0.0	0.0
468+50	50	197.7	0.0	0.0	168.0	0.0	0.0	773.1	0.0	0.0	-605.1	0.0	0.0
469+00	50	396.0	0.0	0.0	336.6	0.0	0.0	472.9	0.0	0.0	-135.2	0.0	0.0
469+50	50	403.0	0.0	0.0	342.6	0.0	0.0	314.0	0.0	0.0	28.5	0.0	0.0
470+00	50	307.1	0.0	0.0	261.0	0.0	0.0	219.6	0.0	0.0	41.4	0.0	0.0
470+50	50	1053.7	0.0	0.0	895.7	0.0	0.0	86.8	0.0	0.0	808.9	0.0	0.0
471+00	50	940.5	0.0	0.0	799.4	0.0	0.0	60.9	0.0	0.0	738.5	0.0	0.0
471+50	50	121.5	0.0	0.0	103.3	0.0	0.0	96.7	0.0	0.0	6.5	0.0	0.0
472+00	50	147.3	0.0	0.0	125.2	0.0	0.0	84.5	0.0	0.0	40.7	0.0	0.0
472+50	50	215.5	0.0	0.0	183.2	0.0	0.0	61.3	0.0	0.0	121.8	0.0	0.0
473+00	50	289.2	0.0	0.0	245.8	0.0	0.0	43.6	0.0	0.0	202.2	0.0	0.0
473+50	50	422.4	0.0	0.0	359.0	0.0	0.0	26.6	0.0	0.0	332.4	0.0	0.0
474+00	50	575.1	0.0	0.0	488.8	0.0	0.0	12.7	0.0	0.0	476.1	0.0	0.0
474+50	50	682.9	0.0	0.0	580.4	0.0	0.0	0.0	0.0	0.0	580.4	0.0	0.0
475+00	50	752.9	0.0	0.0	640.0	0.0	0.0	9.1	0.0	0.0	630.9	0.0	0.0
475+50	50	712.5	0.0	0.0	605.6	0.0	0.0	9.1	0.0	0.0	596.5	0.0	0.0
476+00													



FILE NAME =
 USER NAME = eds
 PLOT SCALE = 1:8000 / IN.
 PLOT DATE = 3/30/2009

DESIGNED - JSM
 DRAWN - JSM
 CHECKED - DNM
 DATE - 3/30/09

REVISED -
 REVISED -
 REVISED -
 REVISED -

**KANE COUNTY
 DIVISION OF TRANSPORTATION**

EARTHWORK TABLES

SCALE: N.T.S. SHEET NO. 1 OF 2 SHEETS STA. TO STA.

F.A. RTE.	SECTION	COUNTY	TOTAL SHEETS	SHEET NO.
361	06-00214-25-BR	KANE	220	12
CONTRACT NO. 63076				
FED. ROAD DIST. NO. 1 ILLINOIS FED. AID PROJECT				

STEARNS ROAD - EARTHWORK CALCULATIONS

STATION	DISTANCE	STAGE 1 EARTH EXCAVATION	STAGE 2 EARTH EXCAVATION	STAGE 3 EARTH EXCAVATION	STAGE 1 EARTH EXCAVATION (ADJ. FOR SHRINKAGE)	STAGE 2 EARTH EXCAVATION (ADJ. FOR SHRINKAGE)	STAGE 3 EARTH EXCAVATION (ADJ. FOR SHRINKAGE)	STAGE 1 EMBNAKMENT	STAGE 2 EMBNAKMENT	STAGE 3 EMBNAKMENT	STAGE 1 EARTHWORK BALANCE WASTE (+) OR SHORTAGE (-)	STAGE 2 EARTHWORK BALANCE WASTE (+) OR SHORTAGE (-)	STAGE 3 EARTHWORK BALANCE WASTE (+) OR SHORTAGE (-)
(XXX+XX)	(FT.)	(CU. YD.)	(CU. YD.)	(CU. YD.)	(CU. YD.)	(CU. YD.)	(CU. YD.)	(CU. YD.)	(CU. YD.)	(CU. YD.)	(CU. YD.)	(CU. YD.)	(CU. YD.)
STEARNS ROAD													
476+00													
476+50	50	838.7	0.0	0.0	712.9	0.0	0.0	0.0	0.0	0.0	712.9	0.0	0.0
477+00	50	1142.2	0.0	0.0	970.9	0.0	0.0	5.1	0.0	0.0	965.7	0.0	0.0
477+50	50	1415.5	0.0	0.0	1203.2	0.0	0.0	5.1	0.0	0.0	1198.1	0.0	0.0
478+00	50	1678.9	0.0	0.0	1427.1	0.0	0.0	0.0	0.0	0.0	1427.1	0.0	0.0
478+50	50	1910.5	0.0	0.0	1623.9	0.0	0.0	0.7	0.0	0.0	1623.2	0.0	0.0
479+00	50	2120.1	0.0	0.0	1802.0	0.0	0.0	2.1	0.0	0.0	1800.0	0.0	0.0
479+50	50	2294.3	0.0	0.0	1950.2	0.0	0.0	3.6	0.0	0.0	1946.6	0.0	0.0
480+00	50	2401.5	0.0	0.0	2041.3	0.0	0.0	4.5	0.0	0.0	2036.8	0.0	0.0
480+50	50	2248.0	0.0	0.0	1910.8	0.0	0.0	23.9	0.0	0.0	1886.9	0.0	0.0
481+00	50	2187.0	0.0	0.0	1858.9	0.0	0.0	203.7	0.0	0.0	1655.2	0.0	0.0
481+50	50	2309.9	0.0	0.0	1963.4	0.0	0.0	683.6	0.0	0.0	1279.8	0.0	0.0
482+00	50	2391.5	0.0	0.0	2032.7	0.0	0.0	1139.3	0.0	0.0	893.5	0.0	0.0
482+50	50	2583.0	0.0	0.0	2280.6	0.0	0.0	1365.1	0.0	0.0	915.4	0.0	0.0
483+00	50	3186.2	0.0	0.0	2708.3	0.0	0.0	1356.9	0.0	0.0	1351.4	0.0	0.0
483+50	50	3547.6	0.0	0.0	3100.4	0.0	0.0	1125.9	0.0	0.0	1974.5	0.0	0.0
484+00	50	3886.0	0.0	0.0	3303.1	0.0	0.0	936.8	0.0	0.0	2366.2	0.0	0.0
484+50	50	4162.6	0.0	0.0	3538.2	0.0	0.0	734.4	0.0	0.0	2803.8	0.0	0.0
485+00	50	4417.4	0.0	0.0	3754.8	0.0	0.0	694.1	0.0	0.0	3060.7	0.0	0.0
485+50	50	4661.2	0.0	0.0	3962.1	0.0	0.0	821.5	0.0	0.0	3140.6	0.0	0.0
486+00	50	4878.8	0.0	0.0	4147.0	0.0	0.0	901.7	0.0	0.0	3245.3	0.0	0.0
486+50	50	4869.3	0.0	0.0	4138.9	0.0	0.0	915.4	0.0	0.0	3223.5	0.0	0.0
487+00	50	4832.3	0.0	0.0	4107.4	0.0	0.0	979.9	0.0	0.0	3127.6	0.0	0.0
487+50	50	5000.7	0.0	0.0	4250.6	0.0	0.0	1068.3	0.0	0.0	3182.3	0.0	0.0
488+00	50	5436.4	0.0	0.0	4620.9	0.0	0.0	986.9	0.0	0.0	3634.0	0.0	0.0
488+50	50	6091.2	0.0	0.0	5177.5	0.0	0.0	780.3	0.0	0.0	4397.3	0.0	0.0
489+00	50	7207.3	0.0	0.0	6126.2	0.0	0.0	453.8	0.0	0.0	5672.4	0.0	0.0
489+50	50	8585.5	0.0	0.0	7382.7	0.0	0.0	138.7	0.0	0.0	7244.0	0.0	0.0
490+00	50	10130.4	0.0	0.0	8610.8	0.0	0.0	3.5	0.0	0.0	8607.3	0.0	0.0
490+50	50	11307.1	0.0	0.0	9611.0	0.0	0.0	3.5	0.0	0.0	9607.6	0.0	0.0
491+00	50	12239.3	0.0	0.0	10403.4	0.0	0.0	3.5	0.0	0.0	10400.0	0.0	0.0
491+50	50	13145.2	0.0	0.0	11173.5	0.0	0.0	3.5	0.0	0.0	11170.0	0.0	0.0
492+00	50	13805.4	0.0	0.0	11734.6	0.0	0.0	3.5	0.0	0.0	11731.1	0.0	0.0
492+50	50	14314.0	0.0	0.0	12166.9	0.0	0.0	3.5	0.0	0.0	12163.5	0.0	0.0
493+00	50	14631.9	0.0	0.0	12437.1	0.0	0.0	3.5	0.0	0.0	12433.7	0.0	0.0
493+50	50	14755.1	0.0	0.0	12541.9	0.0	0.0	3.5	0.0	0.0	12538.4	0.0	0.0
494+00	50	14881.3	0.0	0.0	12649.1	0.0	0.0	3.5	0.0	0.0	12645.7	0.0	0.0
494+50	50	14714.1	0.0	0.0	12507.0	0.0	0.0	3.5	0.0	0.0	12503.5	0.0	0.0
495+00	50	14595.3	0.0	0.0	12406.0	0.0	0.0	3.5	0.0	0.0	12402.6	0.0	0.0
495+50	50	14536.2	0.0	0.0	12355.8	0.0	0.0	3.5	0.0	0.0	12352.3	0.0	0.0
496+00	50	13364.0	0.0	0.0	11359.4	0.0	0.0	3.5	0.0	0.0	11355.9	0.0	0.0
496+50	50	11169.3	0.0	0.0	9493.9	0.0	0.0	3.5	0.0	0.0	9490.4	0.0	0.0
STEARNS ROAD (CU. YD.)		341,916	20,103	6,411	290,628	17,087	5,449	94,714	3,068	418	+195,914	+14,020	+5,031

STATION	DISTANCE	STAGE 1 EARTH EXCAVATION	STAGE 2 EARTH EXCAVATION	STAGE 3 EARTH EXCAVATION	STAGE 1 EARTH EXCAVATION (ADJ. FOR SHRINKAGE)	STAGE 2 EARTH EXCAVATION (ADJ. FOR SHRINKAGE)	STAGE 3 EARTH EXCAVATION (ADJ. FOR SHRINKAGE)	STAGE 1 EMBNAKMENT	STAGE 2 EMBNAKMENT	STAGE 3 EMBNAKMENT	STAGE 1 EARTHWORK BALANCE WASTE (+) OR SHORTAGE (-)	STAGE 2 EARTHWORK BALANCE WASTE (+) OR SHORTAGE (-)	STAGE 3 EARTHWORK BALANCE WASTE (+) OR SHORTAGE (-)
(XXX+XX)	(FT.)	(CU. YD.)	(CU. YD.)	(CU. YD.)	(CU. YD.)	(CU. YD.)	(CU. YD.)	(CU. YD.)	(CU. YD.)	(CU. YD.)	(CU. YD.)	(CU. YD.)	(CU. YD.)
STEARNS ROAD													
496+50	50	9701.0	0.0	0.0	8245.9	0.0	0.0	3.5	0.0	0.0	8242.4	0.0	0.0
497+00	50	9123.2	0.0	0.0	7754.8	0.0	0.0	3.5	0.0	0.0	7751.3	0.0	0.0
497+50	50	6642.9	0.0	0.0	5646.4	0.0	0.0	3.5	0.0	0.0	5643.0	0.0	0.0
498+00	50	3934.5	0.0	0.0	3344.3	0.0	0.0	3.5	0.0	0.0	3340.8	0.0	0.0
498+50	50	2859.1	0.0	0.0	2430.2	0.0	0.0	3.5	0.0	0.0	2426.7	0.0	0.0
499+00	50	1762.6	0.0	0.0	1498.2	0.0	0.0	264.4	0.0	0.0	1233.9	0.0	0.0
499+50	50	998.5	0.0	0.0	848.7	0.0	0.0	935.3	0.0	0.0	-86.6	0.0	0.0
500+00	50	517.0	0.0	0.0	439.5	0.0	0.0	1413.6	0.0	0.0	-974.2	0.0	0.0
500+50	50	197.4	0.0	0.0	167.8	0.0	0.0	1558.5	0.0	0.0	-1390.7	0.0	0.0
501+00	50	46.0	0.0	0.0	39.1	0.0	0.0	1859.3	0.0	0.0	-1820.2	0.0	0.0
501+50	50	7.9	0.0	0.0	6.7	0.0	0.0	2176.1	0.0	0.0	-2169.4	0.0	0.0
502+00	50	8.9	0.0	0.0	7.6	0.0	0.0	2346.6	0.0	0.0	-2339.0	0.0	0.0
502+50	50	67.4	0.0	0.0	57.3	0.0	0.0	2438.4	0.0	0.0	-2381.1	0.0	0.0
503+00	50	119.6	0.0	0.0	101.7	0.0	0.0	2455.0	0.0	0.0	-2353.4	0.0	0.0
503+50	50	100.5	0.0	0.0	85.4	0.0	0.0	2558.0	0.0	0.0	-2472.6	0.0	0.0
504+00	50	105.7	0.0	0.0	89.8	0.0	0.0	2626.6	0.0	0.0	-2536.8	0.0	0.0
504+50	50	179.2	0.0	0.0	152.3	0.0	0.0	2711.8	0.0	0.0	-2559.5	0.0	0.0
505+00	50	210.6	0.0	0.0	179.0	0.0	0.0	3042.6	0.0	0.0	-2863.6	0.0	0.0
505+50	50	97.1	0.0	0.0	82.5	0.0	0.0	3450.7	0.0	0.0	-3368.2	0.0	0.0
506+00	50	7.3	0.0	0.0	6.2	0.0	0.0	3498.8	0.0	0.0	-3492.6	0.0	0.0
506+50	50	109.3	0.0	0.0	92.9	0.0	0.0	3183.2	0.0	0.0	-3090.2	0.0	0.0
507+00	50	148.1	0.0	0.0	125.9	0.0	0.0	3612.7	0.0	0.0	-3486.8	0.0	0.0
507+50	50	154.3	0.0	0.0	131.1	0.0	0.0	3451.8	0.0	0.0	-3320.6	0.0	0.0
508+00	40	174.4	0.0	0.0	148.2	0.0	0.0	1259.3	0.0	0.0	-1111.1	0.0	0.0
STEARNS ROAD (CU. YD.)		341,916	20,103	6,411	290,628	17,087	5,449	94,714	3,068	418	+195,914	+14,020	+5,031

UMBENSTOCK ROAD - EARTHWORK CALCULATIONS

STATION	DISTANCE	EARTH EXCAVATION	EMBANKMENT	EARTH EXCAVATION	EARTH EXCAVATION (ADJ. FOR SHRINKAGE)	EMBANKMENT	EARTHWORK BALANCE WASTE (+) OR SHORTAGE (-)
(XXX+XX)	(FT.)	(SQ. FT.)	(SQ. FT.)	(CU. YD.)	(CU. YD.)	(CU. YD.)	(CU. YD.)
UMBENSTOCK ROAD							
700+25	25	318.5	42.8	278.2	236.5	58.3	178.2
700+50	25	282.4	83.1	226.3	192.3	110.6	81.7
700+75	25	206.4	155.8	146.7	124.7	194.5	-69.8
701+00	25	110.6	264.3	87.1	74.1	225.9	-151.8
701+25	25	77.6	223.6	48.2	41.0	150.5	-109.6
701+50	25	26.5	101.6	34.7	29.5	93.1	-63.6
701+75	25	48.5	99.6	53.5	45.5	64.4	-18.9
702+00	25	67.1	39.5	56.6	48.1	20.8	27.4
702+25	25	55.2	5.4	40.8	34.7	2.5	32.2
702+50	25	33.1	0.0	33.1	0.0	0.0	0.0
TOTAL UMBENSTOCK ROAD (CU. YD.)		972	826	921	-94		

EARTHWORK SCHEDULE					
ITEM	UNIT	STAGE 1	STAGE 2	STAGE 3	UMBENSTOCK RD
EARTH EXCAVATION (20200100)	CU YD	341916	20103	6411	972
EARTH EXCAVATION ADJ. FOR SHRINKAGE	CU YD	290628	17087	5449	826
EMBANKMENT REQUIRED	CU YD	94714	3068	418	921
EARTHWORK BALANCE WASTE (+) OR SHORTAGE (-)	CU YD	+195,914	+14,020	+5,031	-94

RESTRICTED DEPTH MANHOLES, CATCH BASINS, AND INLETS SCHEDULE														
LOCATION		STRUCTURE NO.	RD MAN 4 DIA T1F CL	RD MAN 5 DIA T1F CL	RD MAN 5 DIA T8G	RD MAN 6 DIA T1F CL	RD CB 4 DIA T8G	RD CB 4 DIA T23F&G	RD CB 4 DIA T24F&G	RD CB 5 DIA T23F&G	RD CB 5 DIA T24F&G	RD CB 6 DIA T24F&G	RD INLETS TB T11F&G	RD MAN 6 DIA T1F CL RESTR. PL.
STATION	OFFSET		60224600	60225400	60225900	60226200	60214400	60214713	60214714	60216613	60216614			XX004592
RANDALL ROAD														
469+50	50.0 RT	2		1										
473+00	50.0 RT	3		1										
476+00	50.0 RT	4		1										
477+80	55.0 RT	5		1										
STEARNS ROAD														
436+76.09	92.7 LT	14		1										
436+81.34	87.9 LT	13	1											
436+92.50	66.1 LT	11							1					
437+06.60	70.0 RT	6				1								
437+06.60	56.8 RT	8								1				
437+06.60	9.0 RT	9							1					
437+06.60	60.3 LT	10							1					
438+50	46.3 RT	17							1					
440+50	43.0 RT	21							1					
442+30	57.0 RT	25				1								
442+30	49.0 LT	27							1					
442+60	90.0 RT	30												1
447+53.85	37.0 LT	44							1					
447+53.85	0.7 RT	46							1					
449+50	3.0 LT	50							1					
450+72.81	58.3 LT	53											1	
451+60	9.0 LT	56							1					
454+00	0.9 RT	62							1					
456+50	3.0 LT	66							1					
459+00	9.0 LT	71							1					
459+00	0.4 LT	72						1						
466+15	9.0 LT	79							1					
473+50	68.4 RT	86			1				1					
475+00	68.4 RT	87			1				1					
481+25	9.0 RT	94							1					
483+70	41.0 LT	99							1					
486+00	41.0 LT	102							1					
488+50	41.0 LT	105							1					
498+50	9.0 RT	118							1					
498+50	60.0 RT	119		1										
501+00	40.2 RT	122							1					
501+85	42.1 RT	125							1					
506+00	9.0 LT	131							1					
506+00	55.0 RT	132								1				
506+88.26	9.0 LT	134							1					
506+88.26	55.0 RT	135								1				
507+23	55.0 RT	136								1				
TOTAL:			1	6	2	2	1	4	13	1	6	3	1	1

RIPRAP SCHEDULE												
LOCATION		STRUCTURE NUMBER	PIPE SIZE (IN)	APRON LENGTH (FT)	UPSTREAM WIDTH (FT)	DOWNSTREAM WIDTH (FT)	THICKNESS (IN)	STONE RIPRAP CL A1 (SQ YD)	STONE RIPRAP CL A3 (SQ YD)	STONE RIPRAP CL A4 (SQ YD)	STONE RIPRAP CL A6 (SQ YD)	FILTER FABRIC (SQ YD)
STATION	OFFSET							28100101	28100105	28100107	28100111	28200200
RANDALL ROAD												
469+35	60.0 RT	1	24	20	6	16	20			24		24
STEARNS ROAD												
444+50	61.0 RT	33	18	16	13	13	15		23			23
446+50	58.4 RT	36	12	12	11	11	15		15			15
447+53.85	59.3 RT	47	18	16	11	11	15		20			20
448+00	101.9 RT	38,40,42	18	16	5.5	13.5	15		35			35
449+50	54.8 RT	51	18	16	11	11	15		20			20
449+95	59.2 LT	54	18	16	5.5	13.5	15		17			17
451+60	57.8 RT	58	12	12	11	11	15		15			15
451+77	57.1 LT	60	18	16	5.5	13.5	15		17			17
454+00	57.0 RT	63	12	12	11	11	15		15			15
456+50	57.0 RT	67	12	12	11	11	15		15			15
457+50	72.8 LT	69	18	16	5.5	13.5	15		17			17
459+00	57.0 RT	73	12	12	9	9	15		12			12
463+50	57.3 RT	76	12	12	9	9	15		12			12
466+15	58.6 LT	80	12	12	11	11	15		15			15
470+00	55.9 RT	82	12	12	11	11	15		15			15
476+00	62.8 RT	88	24	20	6	16	20			24		24
477+50	56.4 RT	90	12	12	11	11	15		15			15
479+95	56.1 LT	92	12	12	11	11	15		15			15
481+25	57.0 RT	95	12	12	11	11	15		15			15
489+10	59.0 LT	106	24	20	6	16	20			24		24
491+00	56.0 LT	109	12	12	11	11	15		15			15
493+50	56.0 LT	112	12	12	11	11	15		15			15
496+00	56.0 LT	115	12	12	11	11	15		15			15
504+00	62.0 LT	129	12	12	11	11	15		15			15
508+00	86.0 RT	60° OUTLET WEIR	60	30	31	31	36				104	104
443+25	82.5 RT	OVERFLOW	-	18	50	50	20			100		100
TOTAL:								100	368	172	104	744

OTHER DRAINAGE AND UTILITIES SCHEDULE							
LOCATION		STRUCTURE NO.	MAN ADJUST	MAN RECONST	FIRE HYDNTS MOVED SPL	FIRE HYD W/AUX V & VB	VV TA 4 DIA T1F CL
STATION	OFFSET		60255500	60257900	56400200	56400820	60248700
STEARNS ROAD (STORM SEWER SYSTEM)							
436+51.97	74.6 LT	15	1				
STEARNS ROAD (SANITARY SEWER SYSTEM)							
442+72.21	66.3 LT	1	1				
STEARNS ROAD (WATER MAIN SYSTEM)							
436+69.70	43.0 LT	1					1
436+70	86.8 RT	2				1	
436+93.18	43.0 LT	4		1			
438+77	62.6 LT	3			1		
441+79	58.9 LT	5			1		
442+86.32	36.5 LT	6	1				
444+80	49.6 LT	7			1		
447+70.88	43.6 LT	8		1			
447+95.85	48.3 LT	9			1		
450+64.80	49.0 LT	10			1		
453+78	51.0 LT	11			1		
UMBENSTOCK ROAD (WATER MAIN SYSTEM)							
701+39.85	44.3 LT	12	1				
TOTAL:			4	2	6	1	1

MANHOLES, CATCH BASINS, AND INLETS SCHEDULE																	
LOCATION		STRUCTURE NO.	MAN TA 5 DIA T1F CL	MAN TA 7 DIA T1F CL	MAN TA SPL 9D T1F CL	CB TA 4 DIA T8G	CB TA 5 DIA T24F&G	CB TC T8G	CB TC T23F&G	CB TC T24F&G	INLETS TA T8G	INLETS TA T10F&G	INLETS TA T23F&G	INLETS TA T24F&G	INLETS TB T10F&G	INLETS TB T23F&G	INLETS TB T24F&G
STATION	OFFSET		60221100	60224446	X0325375	60200805	60205040	60207605	60208230	60208240	60236200	60236700	60237460	60237470	60240305	60240327	60240328
STEARNS ROAD																	
436+92.50	61.6 RT	7												1			
436+92.50	75.4 LT	12															
438+50	66.0 RT	16	1														
438+50	9.0 RT	18														1	
438+50	55.0 LT	19															
440+50	62.0 RT	20	1														
440+50	9.0 RT	22														1	
440+50	55.0 LT	23															1
440+50	67.0 LT	24															
442+30	6.0 RT	26				1											
442+30	65.8 LT	28												1			
446+50	37.2 LT	34											1				
446+50	0.0 RT	35				1											
447+39	1.8 RT	45															
447+69	37.0 LT	43															
449+50	37.0 LT	49															1
451+05	9.0 LT	55															
451+60	0.0 RT	57				1											
454+00	9.0 LT	61															
456+50	9.0 LT	64															
457+00	3.0 LT	65															
459+50	9.0 LT	70															
463+50	9.0 LT	74															
463+50	0.0 RT	75				1											
465+60	9.0 LT	77															
466+15	0.0 RT	78															
470+00	0.0 RT	81															
473+50	0.0 RT	85				1											
474+50	0.0 RT	84															
477+50	3.0 RT	89															
479+95	9.0 LT	91															
481+25	0.0 RT	93															
483+70	9.0 RT	97															
483+70	0.0 RT	98				1											
486+00	9.0 RT	100															
486+00	0.0 RT	101				1											
488+50	9.0 RT	103															
488+50	0.0 RT	104				1											
491+00	9.0 RT	107															
491+00	0.0 RT	108				1											
493+50	9.0 RT	110															
493+50	0.0 RT	111				1											
496+00	9.0 RT	113															
496+00	0.0 RT	114				1											
498+50	0.0 RT	117															
501+00	12.2 RT	120															
501+00	69.0 RT	121															
501+85	0.0 RT	123															
501+85	14.1 RT	124															
503+50	76.4 RT	126															
503+50	48.7 RT	127															
504+00	8.0 LT	128															
506+00	90.0 LT	139															
507+00	84.0 RT	137															
507+08	9.0 LT	133															
508+00	90.0 LT	140															
TOTAL:			2	1	1	11	1	2	1	9	8	2	2	10	1	2	3

PRECAST REINFORCED CONCRETE FLARED END SECTIONS SCHEDULE											
LOCATION		STRUCTURE NO.	PRC FLAR END SEC, 12"	PRC FLAR END SEC, 15"	PRC FLAR END SEC, 18"	PRC FLAR END SEC, 24"	PRC FLAR END SEC, 30"	PRC FLAR END SEC, 60"	GRATING FOR PRC FLAR END SEC, 24"	GRATING FOR PRC FLAR END SEC, 30"	GRATING FOR PRC FLAR END SEC, 60"
STATION	OFFSET		54213657	54213660	54213663	54213669	54213675	54213705	54247130	54247150	54247210
RANDALL ROAD											
469+35	60.0 RT	1									
STEARNS ROAD											
442+50	65.5 RT	29					1				
442+80	111.1 RT	31			1						
444+50	62.5 LT	32				1					
444+50	61.0 RT	33					1				
446+50	58.4 RT	36	1								
447+95	66.4 RT	37					1				
447+95	101.9 RT	38						1			
448+00	66.4 RT	39						1			
448+00	101.9 RT	40							1		
448+05	66.4 RT	41								1	
448+05	101.9 RT	42									1
447+53.85	59.3 RT	47									
449+50	55.2 LT	48									
449+50	54.8 RT	51									
449+95	59.2 LT	54									
450+95	58.1 LT	52									
451+60	57.8 RT	58	1								
451+77	57.1 LT	60									
452+50	59.8 LT	59									
454+00	57.0 RT	63	1								
456+50	57.0 RT	67	1								
457+50	72.8 LT	69									
459+00	72.1 LT	68									
459+00	57.0 RT	73	1								
463+50	57.3 RT	76	1								
466+15	58.6 LT	80	1								
470+00	55.9 RT	82	1								
471+30	68.4 RT	83									
476+00	62.8 RT	88									
477+50	56.4 RT	90	1								
479+95	56.1 LT	92	1								
481+25	57.0 RT	95	1								
483+40	59.0 LT	96									
489+10	59.0 LT	106									
491+00	56.0 LT	109	1								
493+50	56.0 LT	112	1								
496+00	56.0 LT	115	1								
497+50	66.5 RT	116									
504+00	62.0 LT	129	1								
505+00	95.0 LT	138									
506+00	69.0 LT	130									
TOTAL:			15	1	17	7	1	1	7	1	1



FILE NAME =
 USER NAME = eds
 DESIGNED - JSM
 DRAWN - JSM
 CHECKED - DNM
 DATE - 3/30/09
 PLOT SCALE = 1:8000 / / IN.
 PLOT DATE = 3/30/2009

REVISED -
 REVISED -
 REVISED -
 REVISED -

**KANE COUNTY
 DIVISION OF TRANSPORTATION**

SCHEDULE OF QUANTITIES
 SCALE: N.T.S. SHEET NO. 2 OF 6 SHEETS STA. TO STA.

F.A. RTE.	SECTION	COUNTY	TOTAL SHEETS	SHEET NO.
361	06-00214-25-BR	KANE	220	15
CONTRACT NO. 63076				
FED. ROAD DIST. NO. 1 ILLINOIS FED. AID PROJECT				

DRAINAGE PIPE SCHEDULE																						
PIPE NO.	DOWNSTREAM STRUCTURE #	PIPE CULVERTS CL. A 18" (FT.)		STORM SEWERS												R.C.E.P. 23X14 (FT.)	S.S. WATERMAIN REQUIREMENTS (FT.)			TRENCH BACKFILL (C.Y.)		
		TYPE 1	TYPE 2	12" DIA. CL. A (FT.)		15" DIA. CL. A (FT.)	18" DIA. CL. A (FT.)		24" DIA. CL. A (FT.)		30" DIA. CL. A (FT.)		36" DIA. CL. A (FT.)	48" DIA. CL. A (FT.)	60" DIA. CL. A (FT.)							
				TYPE 1	TYPE 2	TYPE 1	TYPE 2	TYPE 1	TYPE 2	TYPE 1	TYPE 2	TYPE 2	TYPE 3	TYPE 2	TYPE 2		TYPE 2	TYPE 3	TYPE 4			
542A0223	542A1063	550A0050	550A0340	550A0360	550A0090	550A0380	550A0120	550A0410	550A0430	550A0730	550A0450	550A0480	550A0500	550A0800	550A1100	55035300	X0322033	X0322035	23" X 14"	20800150		
RANDALL ROAD																						
1	2																			10	0.0	
2	3																			345	0.0	
3	4																			295	0.0	
4	5																			176	0.0	
STEARNS ROAD																						
5	5																				127	0.0
6	6																				6	0.0
7	7				12																	1.6
8	8																					8.4
9	9																					11.4
10	10				12																	1.6
11	11				5																	0.0
12	14																					0.0
13	15																					5.0
14	6																					0.0
15	16																					0.0
16	17																					8.7
17	18																					11.1
18	16																					0.0
19	20																					0.0
20	21																					8.4
21	22																					12.5
22	23																					0.2
23	20																					0.0
24	25																					11.2
25	26																					12.1
26	27																					0.0
27	28																					0.0
28	28																					0.0
29	30																					0.0
30	33																					13.7
31	35																					5.4
32	36																					6.8
33	38																					0.0
34	40																					0.0
35	42																					0.0
36	44																					1.8
37	46																					5.3
38	46																					1.9
39	47																					6.6
40	49																					0.2
41	50																					5.8
42	51																					8.9
43	53																					0.2
44	54																					6.3
45	56																					6.9
46	57																					0.0
47	58																					5.6
48	50																					4.7
49	62																					0.3
50	63																					5.6
51	66																					0.5
52	66																					6.7
53	67																					6.1
54	69																					19.5
55	72																					6.9
56	72																					0.0
57	73																					5.3
58	75																					0.4
59	76																					6.4
60	78																					8.0
61	79																					0.0
62	80																					4.5
63	82																					5.2
64	86																					0.0
65	85																					0.0
66	86																					9.1
67	87																					0.0
68	88																					10.9
69	90																					5.1
70	92																					4.5
71	94																					0.0
72	95																					4.5
73	99																					0.6
74	98																					0.4
75	99																					6.5
76	102																					68.5
77	101																					0.4
78	102																					6.5

DRAINAGE PIPE SCHEDULE																						
PIPE NO.	DOWNSTREAM STRUCTURE #	STORM SEWERS															R.C.E.P. 23X14 (FT.)	S.S. WATERMAIN REQUIREMENTS (FT.)			TRENCH BACKFILL (C.Y.)	
		PIPE CULVERTS CL. A 18" (FT.)		12" DIA. CL. A (FT.)		15" DIA. CL. A (FT.)	18" DIA. CL. A (FT.)		24" DIA. CL. A (FT.)		30" DIA. CL. A (FT.)		36" DIA. CL. A (FT.)	48" DIA. CL. A (FT.)	60" DIA. CL. A (FT.)							
		TYPE 1	TYPE 2	TYPE 1	TYPE 2	TYPE 2	TYPE 1	TYPE 2	TYPE 1	TYPE 2	TYPE 2	TYPE 3	TYPE 2	TYPE 2	TYPE 2	TYPE 3		TYPE 4	TYPE 2	12"		18"
		542A0223	542A1063	550A0050	550A0340	550A0360	550A0090	550A0380	550A0120	550A0410	550A0430	550A0730	550A0450	550A0480	550A0500	550A0800	550A1100	55035300	X0322033	X0322035		20800150
STEARNS ROAD																						
79	105										242											85.5
80	104				5																	0.4
81	105				38																	6.5
82	106									53												2.2
83	108				5																	0.3
84	109				48																	5.2
85	111				5																	0.3
86	112				48																	5.2
87	114				5																	0.3
88	115				48																	5.2
89	119									94												0.0
90	118			4																		0.0
91	119				49																	9.3
92	122										251											112.3
93	122				25																	4.9
94	112				26																	2.9
95	125									81												113.8
96	124			11																		0.2
97	125				25																	3.8
98	127										161											237.2
99	127				25																	2.8
100				48																		5.3
101	130											245										309.0
102	129									49												20.8
103	130									60												42.4
104	133												83									53.3
105	132				17																	2.6
106	133				60																	9.2
107	134												29									23.0
108	139												71									56.5
109													32									37.4
110					1																	0.0
111	137													89								0.0
112	138														192							0.0
113	139																					623.5
114																						23.4
		64	216	504	1165	103	98	164	1222	1363	190	412	245	215	89	192	163	44	194	142	70	2189.4

STEEL CASING SCHEDULE		
LOCATION	OFFSET	STEEL CASING PIPE 18" (FOOT)
STEARNS RD		XX006258
456+00		96
TOTAL		96

TRENCH BACKFILL SCHEDULE	
LOCATION	TRENCH BACKFILL (C.Y.)
STATION	20800150
PIPE QUANTITIES	
	2189.4
PIPE CULVERT REMOVAL QUANTITIES	
439+42	14.5
442+40	13.7
450+00	7.0
451+92	10.8
452+84	5.8
EXPLORATORY TRENCH QUANTITIES	
	44.5
WATERMAIN QUANTITIES	
436+69	29.8
STEEL CASING QUANTITIES	
456+00	21.4
TOTAL: 2337	

PIPE UNDERDRAIN SCHEDULE	
PIPE NO.	PIPE UNDERDRAINS (FT)
	6"
	60107700
A	58
B	60
C	52
D	69
E	52
F	65
G	96
H	46
I	60
J	94
K	34
L	63
M	100
N	60
O	97
P	97
Q	34
R	105
S	97
T	52
U	52
V	52
W	52
X	52
Y	69
Z	50
AA	54
AB	69
AC	57
AD	52
AE	53
AF	54
AG	84
AH	84
AI	84
AJ	98
AK	98
AL	53
AM	60
AN	57
AO	43
AP	53
AQ	55
AR	53
AS	66
AT	52
AU	64
AV	52
TOTAL 3113	

REMOVAL SCHEDULE								
STATION		TREE REMOVAL (6 TO 15 UNITS DIAMETER) (UNITS)	TREE REMOVAL (OVER 15 UNITS DIAMETER) (UNITS)	PAVEMENT REMOVAL (SQ YD)	HOT-MIX ASPHALT SURFACE REMOVAL, 2" (SQ YD)	DRIVEWAY PAVEMENT REMOVAL (SQ YD)	COMBINATION CURB AND GUTTER REMOVAL (FOOT)	PIPE CULVERT REMOVAL (FOOT)
		20100110	20100210	44000100	44000157	44000200	44000500	50105220
STEARNS RD	434+00 TO 447+00	114	261	5,610		575	222	167
	447+00 TO 460+00	204	144	5,265		620		106
	460+00 TO 473+00	222	19	679				
	473+00 TO 486+00	219	0	2,370				
	486+00 TO 499+00	104	0	4,366				
	499+00 TO 508+40	777	33	2,137				
RANDALL RD					8,578		80	
TOTAL		1,640	457	20,427	8,578	1,195	302	273

MEDIAN SCHEDULE						
STATION		COMBINATION CONCRETE CURB AND GUTTER, TYPE M-6.06 (FOOT)	CONCRETE MEDIAN SURFACE, 4 INCH (SQ FT)	CONCRETE MEDIAN, TYPE SB-6.24 (SQ FT)	CONCRETE MEDIAN, TYPE SB-6.24 (MODIFIED) (SQ FT)	CORRUGATED MEDIAN (SQ FT)
		60608600	60618300	60620000	60620200	60624600
STEARNS RD	434+00 TO 447+00			261	2537	127
	447+00 TO 460+00			1,021	2506	200
	460+00 TO 473+00			0	0	0
	473+00 TO 486+00			487	960	97
	486+00 TO 499+00			0	0	0
	499+00 TO 508+40			261	2118	0
UMBENSTOCK RD		700+50 TO 702+50	18	162		
TOTAL		18	162	2,030	8121	424

PAVEMENT SCHEDULE													
STATION		PORTLAND CEMENT CONCRETE PAVEMENT 10" (JOINTED) (SQ YD)	PORTLAND CEMENT CONCRETE SHOULDERS 6", SPECIAL (SQ YD)	AGGREGATE SHOULDERS, TYPE B 6" (SQ YD)	HOT-MIX ASPHALT SHOULDERS, 6" (SQ YD)	HMA ASPHALT PAVEMENT (FULL-DEPTH), 10 3/4" (SQ YD)	POLYMERIZED HOT MIX ASPHALT SURFACE COURSE MIX F N90 2" (TON)	HOT-MIX ASPHALT SURFACE COURSE, MIX "C", N50 (TON)	HMA BASE COURSE, 8" (SQ YD)	SUB-BASE GRANULAR MATERIAL TYPE B (TON)	AGGREGATE SUBGRADE 12" (SQ YD)	AGGREGATE BASE COURSE, TYPE B 6" (SQ YD)	CLASS D PATCHES, TYPE IV, 12 INCH
		42000501		48101500	48203021	40701896	40603595	40603310	35501316	31101000	Z0001050	35101800	44201796
STEARNS RD	434+00 TO 447+00	7734	404	101		2,458		30	264	32	12,104	271	387
	447+00 TO 460+00	10163	1967	555				21	163	103	13,257	160	136
	460+00 TO 473+00	7505	2090	590						90	10,774		
	473+00 TO 486+00	8401	1981	508						95	11,544		
	486+00 TO 499+00	7265	1924	441	106					172	10,525		
	499+00 TO 508+40	7368	810	199	298					25	9,315		
RANDALL RD		478+67 TO 487+80					961						
TOTAL		48436	9176	2,394	404	2,458	961	51	427	517	67,519	431	523

CURB AND GUTTER SCHEDULE						
STATION		CLASS SI CONCRETE OUTLET (CU YD)	CONCRETE GUTTER, TYPE A (FOOT)	COMBINATION CONCRETE CURB AND GUTTER, TYPE B-6.12 (FOOT)	COMBINATION CONCRETE CURB AND GUTTER, TYPE B-6.24 (FOOT)	
		60600095	60602500	60603800	60605000	
					OUTER EDGE	MEDIAN
STEARNS RD	434+00 TO 447+00			73	1780	1135
	447+00 TO 460+00			96	292	1051
	460+00 TO 473+00				0	2600
	473+00 TO 486+00				256	1894
	486+00 TO 499+00	1.7			432	2600
	499+00 TO 508+40	2.1	946		946	1107
TOTAL		3.8	946	169	3706	10387

PRIME COAT SCHEDULE		
LOCATION	BITUMINOUS MATERIALS (PRIME COAT) (GAL)	AGGREGATE (PRIME COAT) (TON)
	40600100	40600300
RANDALL RD RESURFACING	858	17
STEARNS RD RECONSTRUCTION	492	10
COMMERCIAL DRIVEWAYS	85	2
TOTAL	1435	29

PAVEMENT MARKING SCHEDULE																
STATION		PAINT PAVEMENT MARKING - LINE 4" (FOOT)	PAINT PAVEMENT MARKING - LINE 12" (FOOT)	EPOXY PAVEMENT MARKING - LETTERS AND SYMBOLS (SQ FT)	EPOXY PAVEMENT MARKING - LINE 4" (FOOT)	EPOXY PAVEMENT MARKING - LINE 6" (FOOT)	EPOXY PAVEMENT MARKING - LINE 8" (FOOT)	EPOXY PAVEMENT MARKING - LINE 12" (FOOT)	EPOXY PAVEMENT MARKING - LINE 24" (FOOT)	POLYUREA PAVEMENT MARKING TYPE I - LETTERS AND SYMBOLS (SQ FT)	POLYUREA PAVEMENT MARKING TYPE I - LINE 4" (FOOT)	POLYUREA PAVEMENT MARKING TYPE I - LINE 6" (FOOT)	POLYUREA PAVEMENT MARKING TYPE I - LINE 8" (FOOT)	POLYUREA PAVEMENT MARKING TYPE I - LINE 12" (FOOT)	POLYUREA PAVEMENT MARKING TYPE I - LINE 24" (FOOT)	RECESSED REFLECTIVE PAVEMENT MARKERS (EACH)
		78001110	78001150	78005100	78005110	78005130	78005140	78005150	78005180	78008200	78008210	78008230	78008240	78008250	78008270	XX006257
STEARNS RD	434+00 TO 447+00			182	280	270	336	152	120	438	4,188	1,171				
	447+00 TO 460+00	80	5							456	5,140	414				
	460+00 TO 473+00	1008	90							36	5,853	262				
	473+00 TO 486+00									334	5,674	404			26	
	486+00 TO 499+00										5,850	0				
	499+00 TO 508+40									458	4,232	1,193				
RANDALL RD	478+67 TO 487+80			255	322	1,342			96							20
McDONALD RD	428+70 TO 436+27			255	240	1,162	277	161	69							24
UMBDENSTOCK RD	700+50 TO 702+50									137	996	148	312	95	31	
TOTAL		1088	95	692	842	2,774	613	313	285	1859	31,933	3,592	312	95	57	44

MAINTENANCE OF TRAFFIC SCHEDULE							
MAINTENANCE OF TRAFFIC STAGE	TEMPORARY PAVEMENT MARKING - LETTERS AND SYMBOLS (SQ FT)	TEMPORARY PAVEMENT MARKING - LINE 4" (FOOT)	PAVEMENT MARKING TAPE, TYPE III - LETTERS AND SYMBOLS (SQ FT)	PAVEMENT MARKING TAPE, TYPE III 4" (FOOT)	WORK ZONE PAVEMENT MARKING REMOVAL (SQ FT)	TEMPORARY RAMP (SY)	TEMPORARY PAVEMENT 8" (SY)
	70300210	70300220	70300510	70300520	70301000	40600990	XX003404
STAGE 2A	156	8,522	0	1,702	3,395		1,925
STAGE 2B	0	260	0	1,034	471		40
STAGE 3A	121	3,161	109	9,042	2,888	781	
STAGE 3B	0	0	0	1,245	353		
STAGE 4A	0	0	48	4,115	2,619	821	
STAGE 4B	0	0	73	1,820	3,639		
TOTAL	277	11,943	230	18,958	13,365	1,602	1,965

LANDSCAPING SCHEDULE						
STATION	TOPSOIL FURNISH AND PLACE, 4" (SQ YD)	TOPSOIL FURNISH AND PLACE, 24" (SQ YD)	NITROGEN FERTILIZER NUTRIENT (POUND)	PHOSPHORUS FERTILIZER NUTRIENT (POUND)	POTASSIUM FERTILIZER NUTRIENT (POUND)	
	21101615	21101685	25000400	25000500	25000600	
STEARNS RD	434+00 TO 447+00	14,383	1,041	144	144	144
	447+00 TO 460+00	17,654	586	228	228	228
	460+00 TO 473+00	16,007	1,855	332	332	332
	473+00 TO 486+00	19,401	1,245	384	384	384
	486+00 TO 499+00	41,354	1,855	803	803	803
	499+00 TO 508+40	11,659	995	235	235	235
RANDALL RD	469+35 TO 477+50	1,594		30	30	30
TOTAL	122,052	7,577	2,156	2,156	2,156	

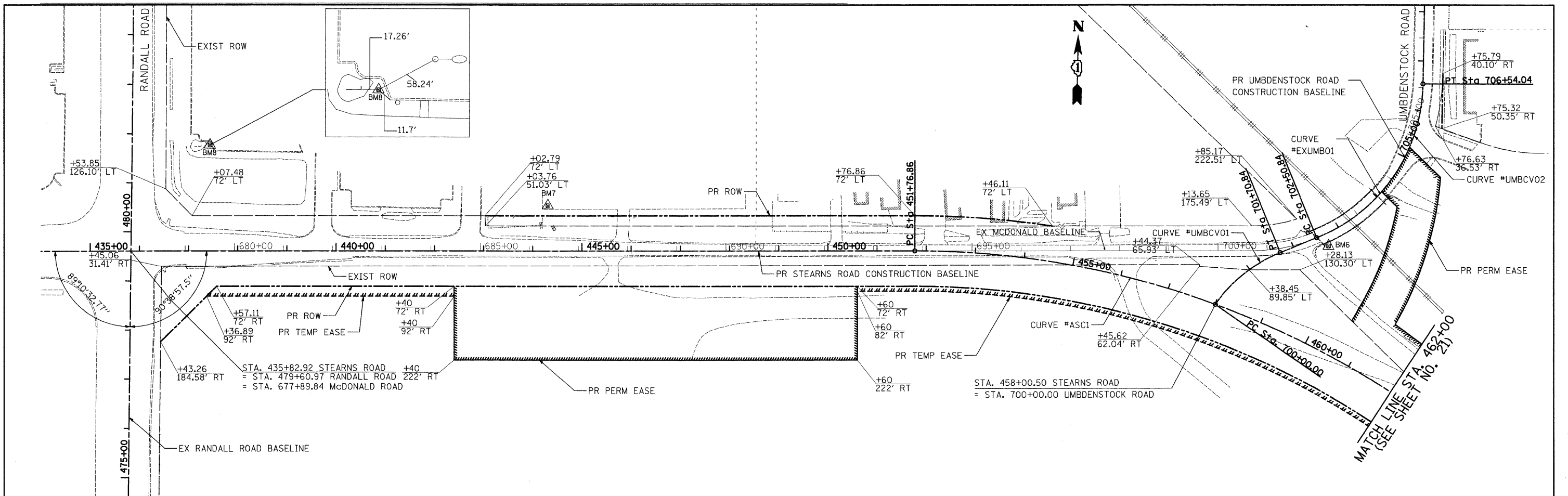

EXISTING RANDALL ROAD BASELINE			
DESCRIPTION	STATION	NORTHING	EASTING
B.O.A.	461+24.26	1935349.54	982260.37
E.O.A.	483+00.00	1937525.23	982244.88

EXISTING MCDONALD ROAD BASELINE			
DESCRIPTION	STATION	NORTHING	EASTING
B.O.A.	677+89.84	1937186.49	982247.30
P.C.	700+69.57	1937228.10	984526.64
P.I.	704+10.94	1937234.34	984867.96
P.T.	706.09.10	1937575.71	984867.55
E.O.A.	710+00.66	1937967.27	984867.13

PROPOSED STEARNS ROAD CONSTRUCTION BASELINE			
DESCRIPTION	STATION	NORTHING	EASTING
B.O.A.	403+00.00	1937115.61	978965.14
P.I.	435+82.92	1937186.20	982247.30
P.C.	451+76.86	1937215.61	983840.97
P.T.	458+98.03	1937228.92	984562.01
P.T.	465+45.97	1936733.07	985085.67
P.C.	481+79.54	1935609.89	986271.84
P.I.	491+98.78	1934909.09	987011.94
P.T.	501+29.92	1934867.24	988030.32
E.O.A.	544+54.78	1934689.66	992351.53

PROPOSED UMBDENSTOCK ROAD CONSTRUCTION BASELINE			
DESCRIPTION	STATION	NORTHING	EASTING
B.O.A.	700+00.00	1937117.74	984453.59
P.C.	700+00.00	1937117.74	984453.59
P.I.	700+87.89	1937190.78	984502.47
P.T.	701+70.84	1937225.16	984583.36
P.C.	702+50.84	1937256.45	984656.99
P.I.	704+79.03	1937345.71	984866.99
P.T.	706+54.04	1937573.89	984867.04
E.O.A.	710+47.42	1937967.27	984867.13

PROP. CURVE UMBCV01
 PI STA. = 700+87.89
 $\Delta = 33^\circ 10' 55''$ (RT)
 $D = 19^\circ 25' 20''$
 $R = 295.00'$
 $T = 87.89'$
 $L = 170.84'$
 $E = 12.82'$
 $e = 6.0\%$
 $T.R. = 90$
 $S.E. RUN = 120$
 $P.C. STA = 700+00.00$
 $P.T. STA = 701+70.84$

PROP. CURVE ASC1
 PI STA. = 458+98.03
 $\Delta = 44^\circ 29' 41''$ (RT)
 $D = 3^\circ 15' 00''$
 $R = 1,763.00'$
 $T = 721.17'$
 $L = 1,369.11'$
 $E = 141.80'$
 $e = 3.02\%$
 $T.R. = 68$
 $S.E. RUN = 102$
 $P.C. STA = 451+76.86$
 $P.T. STA = 465+45.97$

PROP. CURVE UMBCV02
 PI STA. = 704+79.03
 $\Delta = 66^\circ 57' 40''$ (LT)
 $D = 16^\circ 36' 27''$
 $R = 345.00'$
 $T = 228.18'$
 $L = 403.20'$
 $E = 68.63'$
 $e = N/A$
 $P.C. STA = 702+50.84$
 $P.T. STA = 706+54.04$

EXIST. CURVE EXUMBO1
 PI STA. = 704+10.94
 $\Delta = 89^\circ 01' 18.1''$ (LT)
 $D = 16^\circ 29' 59.7''$
 $R = 347.25'$
 $T = 341.37'$
 $L = 539.53'$
 $e = 139.70'$
 $e = 6.0\%$
 $P.C. STA = 700+69.57$
 $P.T. STA = 706+09.10$

NUMBER	STA. & OFFSET FROM PR	DESCRIPTION	ELEVATION
BM6	702+66.89 24.97 RT	"CHISELED BOX CUT" ON TOP OF GUARD WALL AT THE SOUTHEAST CORNER OF BRIDGE CROSSING RR TRACKS, JUST SOUTH OF INTERSECTION OF UMBDENSTOCK ROAD AND MCDONALD ROAD	821.99
BM7	444+30.64 92.60 LT	"CHISELED BOX CUT" ON THE NORTH TOP OF CONCRETE LIGHT POLE BASE, LIGHT POLE IS AT THE SOUTHWEST CORNER OF ASPHALT PARKING LOT OF BIRDIES AND EAGLES DRIVING RANGE.	810.50
BM8	447+43.53 215.88 LT	"ALUMINUM DISK" SET IN CONCRETE AT THE NORTHEAST CORNER OF MCDONALD ROAD AND RANDALL ROAD IN THE SOUTHWEST CORNER OF THE JEWEL PARKING LOT.	805.97
BM15		"ALUMINUM DISK" SET IN CONCRETE AT THE SOUTHWEST CORNER OF ROUTE 31 AND MCLEAN BOULEVARD	716.31

SECTION MARKERS SHALL BE RECORDED AND REINSTALLED ACCORDING TO THE SPECIAL PROVISION FOR SECTION MARKERS. SEE PLATS FOR LOCATIONS OF SECTION MARKERS WITHIN PROJECT LIMITS.

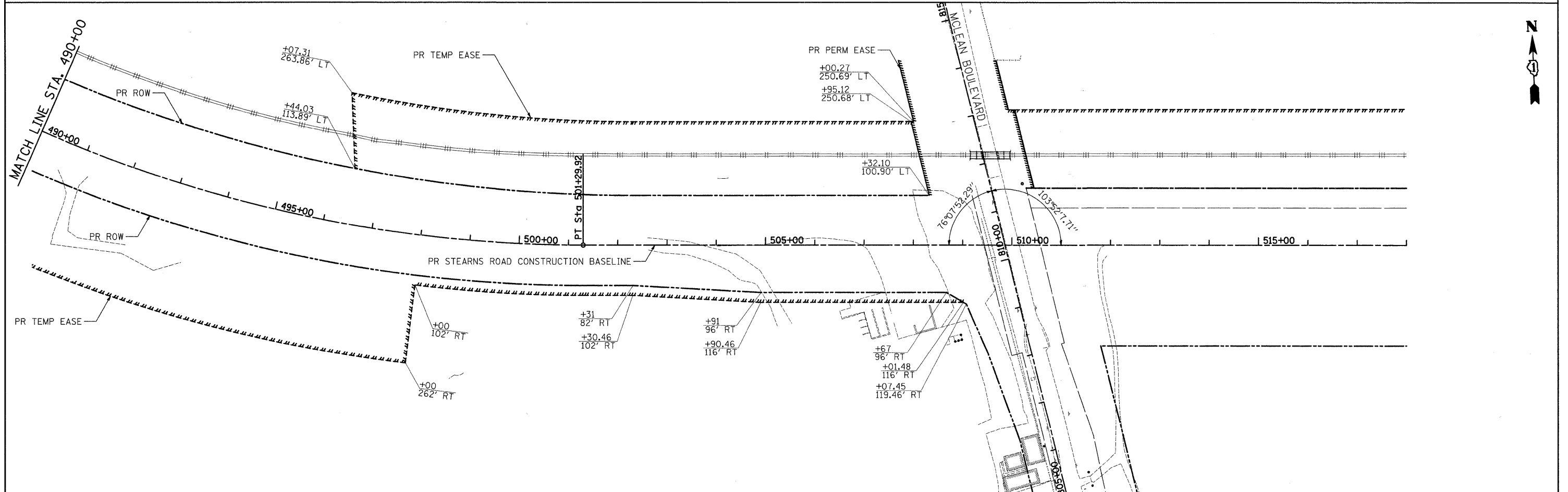
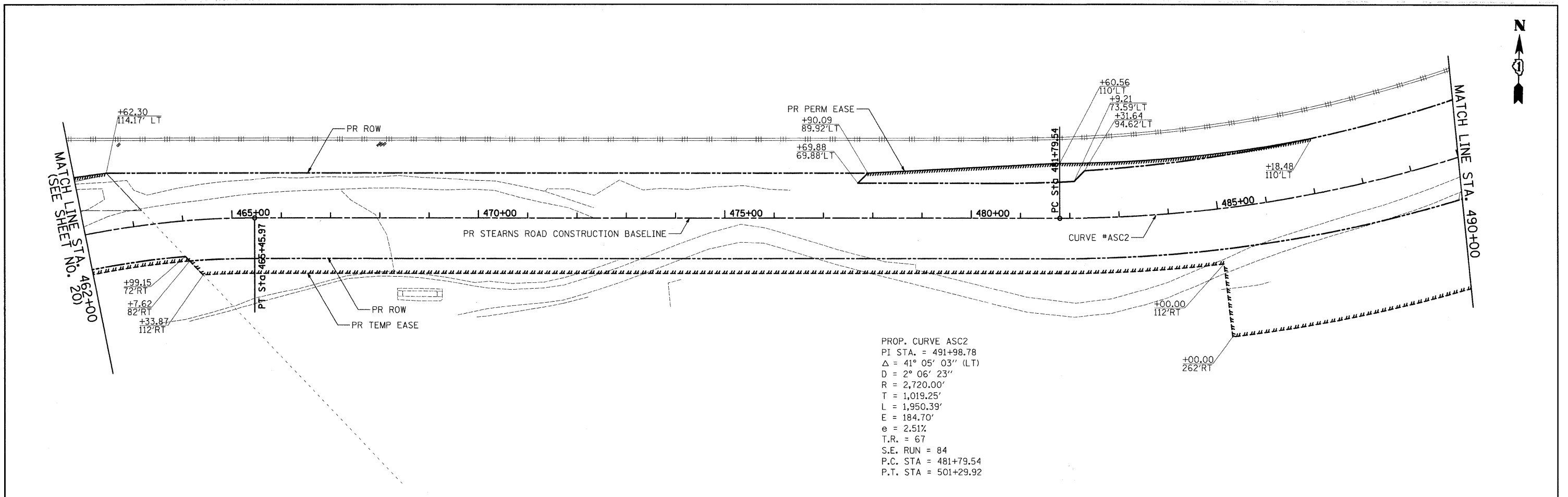

FILE NAME =	USER NAME = jsm	DESIGNED - EAD	REVISED -	KANE COUNTY DIVISION OF TRANSPORTATION	ALIGNMENT, TIES, BENCHMARKS AND ROW	F.A. RTE.	SECTION	COUNTY	TOTAL SHEETS	SHEET NO.	
	PLOT SCALE = 100.0000' / IN.	DRAWN - EAD	REVISED -			361	06-00214-25-BR	KANE	220	21	
PLOT DATE = 3/27/2009	CHECKED - DNM	DATE - 3/30/09	REVISED -			CONTRACT NO. 63076					
						SCALE: 1" = 100' SHEET NO. 2 OF 2 SHEETS STA. 490+00 TO STA. 508+40 FED. ROAD DIST. NO. 1 ILLINOIS FED. AID PROJECT					

STEARNS ROAD SUPERELEVATION TABLE
CURVE #1

	WESTBOUND										EASTBOUND					
	STATION	MAINLINE LEFT E.O.P. (P.G.L.) ELEVATION	CROSS SLOPE %	MAINLINE LEFT E.O.P. ELEVATION (24' RT OF PGL)	RIGHT TURN E.O.P. DISTANCE LEFT OF E.O.P. (FT)	CROSS SLOPE %	RIGHT TURN E.O.P. ELEVATION	LEFT TURN E.O.P. DISTANCE RIGHT OF P.G.L. (FT)	CROSS SLOPE %	LEFT TURN E.O.P. ELEVATION	MAINLINE RIGHT E.O.P. (P.G.L.) ELEVATION	CROSS SLOPE %	MAINLINE RIGHT E.O.P. ELEVATION (24' RT OF PGL)	LEFT TURN E.O.P. DISTANCE LEFT OF P.G.L. (FT)	CROSS SLOPE %	LEFT TURN E.O.P. ELEVATION
	450+00.00	811.69	-2.00%	811.21	-	-	-	-	-	811.69	-2.00%	811.21	-	-	-	
	450+25.00	811.89	-2.00%	811.41	-	-	-	-	-	811.89	-2.00%	811.41	-	-	-	
BEGIN TANGENT RUNOUT	450+35.00	811.97	-2.00%	811.49	-	-	-	-	-	811.97	-2.00%	811.49	-	-	-	
	450+50.00	812.09	-1.57%	811.71	-	-	-	-	-	812.09	-2.00%	811.61	-	-	-	
	450+75.00	812.29	-0.86%	812.08	-	-	-	-	-	812.29	-2.00%	811.81	-	-	-	
	451+00.00	812.49	-0.14%	812.46	-	-	-	-	-	812.49	-2.00%	812.01	-	-	-	
	451+05.00	812.53	0.00%	812.53	-	-	-	-	-	812.53	-2.00%	812.05	-	-	-	
	451+25.00	812.69	0.58%	812.83	-	-	-	-	-	812.69	-2.00%	812.21	-	-	-	
	451+50.00	812.89	1.29%	813.20	-	-	-	-	-	812.89	-2.00%	812.41	-	-	-	
	451+75.00	813.09	2.01%	813.57	-	-	-	-	-	813.09	-2.01%	812.61	-	-	-	
	452+00.00	813.29	2.73%	813.94	-	-	-	-	-	813.29	-2.73%	812.63	-	-	-	
BEGIN FULL SUPERELEVATION	452+10.00	813.37	3.02%	814.09	-	-	-	-	-	813.37	-3.02%	812.65	-	-	-	
	453+00.00	814.08	3.02%	814.81	-	-	-	-	-	814.084	-3.02%	813.36	1.60	-1.50%	814.06	
	454+00.00	814.88	3.02%	815.61	-	-	-	-	-	814.88	-3.02%	814.16	8.15	-1.50%	814.76	
	455+00.00	815.68	3.02%	816.40	-	-	-	-	-	815.68	-3.02%	814.95	12.00	-1.50%	815.50	
	456+00.00	816.47	3.02%	817.20	-	-	-	-	-	816.47	-3.02%	815.75	12.00	-1.50%	816.29	
	457+00.00	817.27	3.02%	818.00	-	-	-	-	-	817.27	-3.02%	816.55	12.00	-1.50%	817.09	
	458+00.00	818.07	3.02%	818.79	-	-	-	-	-	818.07	-3.02%	817.35	12.00	-1.50%	817.89	
	459+00.00	818.87	3.02%	819.59	13.00	-1.50%	819.40	12.00	-1.50%	818.69	818.87	-3.02%	818.14	-	-	
	460+00.00	819.60	3.02%	820.33	12.00	-1.50%	820.15	12.00	-1.50%	819.42	819.60	-3.02%	818.88	-	-	
	461+00.00	819.97	3.02%	820.70	12.00	-1.50%	820.52	9.95	-1.50%	819.82	819.97	-3.02%	819.25	-	-	
	462+00.00	819.91	3.02%	820.63	10.80	-1.50%	820.47	4.24	-1.50%	819.84	819.91	-3.02%	819.18	-	-	
	463+00.00	819.46	3.02%	820.18	5.09	-1.08%	820.13	-	-	-	819.46	-3.02%	818.74	-	-	
	464+00.00	818.96	3.02%	819.68	-	-	-	-	-	818.96	-3.02%	818.24	-	-	-	
	465+00.00	818.46	3.02%	819.18	-	-	-	-	-	818.46	-3.02%	817.74	-	-	-	
END FULL SUPERELEVATION	465+10.00	818.41	3.02%	819.13	-	-	-	-	-	818.41	-3.02%	817.69	-	-	-	
	465+25.00	818.34	2.59%	818.96	-	-	-	-	-	818.34	-2.87%	817.65	-	-	-	
	465+50.00	818.21	1.87%	818.66	-	-	-	-	-	818.21	-2.63%	817.58	-	-	-	
	465+75.00	818.09	1.15%	818.37	-	-	-	-	-	818.09	-2.39%	817.52	-	-	-	
	466+00.00	817.96	0.43%	818.06	-	-	-	-	-	817.96	-2.15%	817.45	-	-	-	
END SUPERELEVATION RUNOFF	466+15.00	817.89	0.00%	817.89	-	-	-	-	-	817.89	-2.00%	817.41	-	-	-	
	466+25.00	817.84	-0.29%	817.77	-	-	-	-	-	817.84	-2.00%	817.36	-	-	-	
	466+50.00	817.71	-1.00%	817.47	-	-	-	-	-	817.71	-2.00%	817.23	-	-	-	
	466+75.00	817.59	-1.71%	817.18	-	-	-	-	-	817.59	-2.00%	817.11	-	-	-	
END TANGENT RUNOUT	466+85.00	817.54	-2.00%	817.06	-	-	-	-	-	817.54	-2.00%	817.06	-	-	-	
	467+00.00	817.46	-2.00%	816.98	-	-	-	-	-	817.46	-2.00%	816.98	-	-	-	
	467+25.00	817.34	-2.00%	816.86	-	-	-	-	-	817.34	-2.00%	816.86	-	-	-	
	467+50.00	817.21	-2.00%	816.73	-	-	-	-	-	817.21	-2.00%	816.73	-	-	-	

STEARNS ROAD SUPERELEVATION TABLE
CURVE #2

	WESTBOUND				EASTBOUND						
	STATION	MAINLINE LEFT E.O.P. (P.G.L.) ELEVATION	CROSS SLOPE %	MAINLINE LEFT E.O.P. ELEVATION (24' LT OF PGL)	MAINLINE RIGHT E.O.P. (P.G.L.) ELEVATION	CROSS SLOPE %	MAINLINE RIGHT E.O.P. ELEVATION (24' RT OF PGL)	RIGHT E.O.P. DISTANCE RIGHT OF E.O.P. (FT)	CROSS SLOPE %	RIGHT E.O.P. ELEVATION	STATION
	480+25.00	810.84	-2.00%	810.36	810.84	-2.00%	810.36				480+25.00
	480+50.00	810.71	-2.00%	810.23	810.71	-2.00%	810.23				480+50.00
BEGIN TANGENT RUNOUT	480+55.00	810.69	-2.00%	810.21	810.69	-2.00%	810.21				480+55.00
	480+75.00	810.59	-2.00%	810.11	810.59	-1.43%	810.25				480+75.00
	481+00.00	810.46	-2.00%	809.98	810.46	-0.71%	810.29				481+00.00
	481+25.00	810.34	-2.00%	809.86	810.34	0.00%	810.34				481+25.00
	481+50.00	810.21	-2.00%	809.73	810.21	0.74%	810.39				481+50.00
	481+75.00	810.09	-2.00%	809.61	810.09	1.48%	810.44				481+75.00
	482+00.00	809.96	-2.21%	809.43	809.96	2.21%	810.49				482+00.00
BEGIN FULL SUPERELEVATION	482+10.00	809.91	-2.51%	809.31	809.91	2.51%	810.51				482+10.00
	483+00.00	809.46	-2.51%	808.86	809.46	2.51%	810.06				483+00.00
	484+00.00	808.96	-2.51%	808.36	808.96	2.51%	809.56				484+00.00
	485+00.00	808.46	-2.51%	807.86	808.46	2.51%	809.06				485+00.00
	486+00.00	807.61	-2.51%	807.01	807.61	2.51%	808.21				486+00.00
	487+00.00	805.67	-2.51%	805.07	805.67	2.51%	806.27				487+00.00
	488+00.00	802.64	-2.51%	802.04	802.64	2.51%	803.24				488+00.00
	489+00.00	798.85	-2.51%	798.25	798.85	2.51%	799.45				489+00.00
	490+00.00	795.04	-2.51%	794.44	795.04	2.51%	795.64				490+00.00
	491+00.00	791.23	-2.51%	790.63	791.23	2.51%	791.83				491+00.00
	492+00.00	787.42	-2.51%	786.82	787.42	2.51%	788.02				492+00.00
	493+00.00	783.61	-2.51%	783.01	783.61	2.51%	784.21	-	-	-	493+00.00
	494+00.00	779.80	-2.51%	779.20	779.80	2.51%	780.41	-	-	-	494+00.00
	495+00.00	775.99	-2.51%	775.39	775.99	2.51%	776.59	-	-	-	495+00.00
	496+00.00	772.19	-2.51%	771.58	772.19	2.51%	772.79	-	-	-	496+00.00
	497+00.00	768.38	-2.51%	767.78	768.38	2.51%	768.98	-	-	-	497+00.00
	498+00.00	764.57	-2.51%	763.97	764.57	2.51%	765.17	-	-	-	498+00.00
	499+00.00	760.76	-2.51%	760.16	760.76	2.51%	761.36	4.00	-4.00%	761.20	499+00.00
	500+00.00	756.95	-2.51%	756.35	756.95	2.51%	757.55	4.00	-4.00%	757.39	500+00.00
END FULL SUPERELEVATION	501+00.00	753.14	-2.51%	752.54	753.14	2.51%	753.74	4.00	-4.00%	753.58	501+00.00
	501+25.00	752.19	-2.36%	751.62	752.19	1.77%	752.62	-	-	-	501+25.00
	501+50.00	751.24	-2.21%	750.71	751.24	1.03%	751.48	4.00	-4.00%	751.32	501+50.00
	501+75.00	750.28	-2.06%	749.79	750.28	0.30%	750.35	-	-	-	501+75.00
END SUPERELEVATION RUNOFF	501+85.00	749.91	-2.00%	749.43	749.91	0.00%	749.91	-	-	-	501+85.00
	502+00.00	749.33	-2.00%	748.85	749.33	-0.43%	749.23	4.00	-4.00%	749.07	502+00.00
	502+25.00	748.38	-2.00%	747.90	748.38	-1.14%	748.11	-	-	-	502+25.00
	502+50.00	747.43	-2.00%	746.95	747.43	-1.86%	746.98	-	-	-	502+50.00
END TANGENT RUNOUT	502+55.00	747.24	-2.00%	746.76	747.24	-2.00%	746.76	-	-	-	502+55.00
	502+75.00	746.48	-2.00%	746.00	746.48	-2.00%	746.00	-	-	-	502+75.00

UMBDENSTOCK ROAD SUPERELEVATION TABLE

	SOUTHBOUND				NORTHBOUND			
	STATION	MAINLINE LEFT E.O.P. ELEVATION	CROSS SLOPE %	MAINLINE CENTERLINE ELEVATION	MAINLINE CENTERLINE ELEVATION	CROSS SLOPE %	MAINLINE RIGHT E.O.P. ELEVATION	STATION
	700+00.00		-2.00%	818.07	818.07	-2.00%		700+00.00
	700+25.00	817.88	-2.00%	818.65	818.65	-2.00%		700+25.00
	700+50.00	818.68	-2.00%	819.30	819.30	-2.00%		700+50.00
	700+75.00	819.13	-2.00%	819.61	819.61	-2.00%		700+75.00
	701+00.00	819.1	-2.00%	819.58	819.58	-2.00%	818.78	701+00.00
	701+25.00	818.72	-2.00%	819.20	819.20	-2.00%	818.66	701+25.00
BEGIN TANGENT RUNOUT	701+30.00	818.59	-2.00%	819.10	819.10	-2.00%	818.64	701+30.00
	701+50.00	818.08	-2.66%	818.72	818.72	-0.71%	818.58	701+50.00
	701+75.00	817.53	-3.49%	818.35	818.54	0.00%	818.54	701+61.00
	702+00.00	817.24	-4.31%	818.12	818.35	0.93%	818.49	701+75.00
	702+25.00	817.14	-5.14%	818.04	818.12	2.60%	818.51	702+00.00
	702+50.00	817.19	-5.97%	818.10	818.04	4.27%	818.68	702+25.00
BEGIN FULL SUPERELEVATION	702+51.00	817.19	-6.00%	818.10	818.10	5.93%	818.99	702+50.00
					818.10	6.00%	819.00	702+51.00

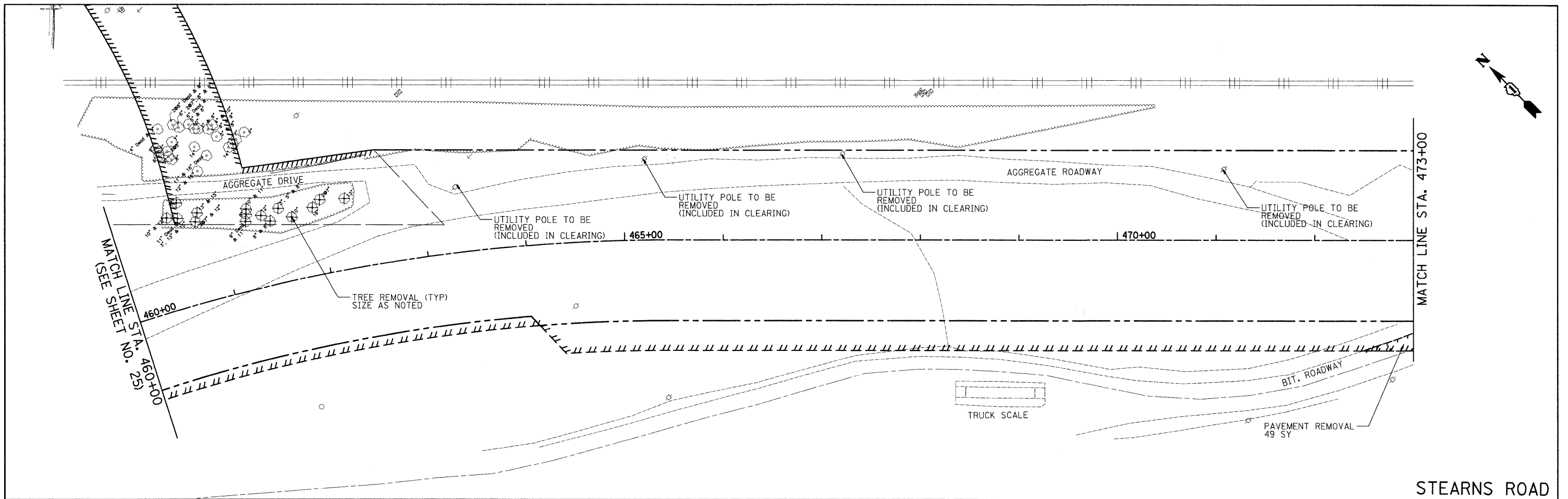

STEARNS ROAD

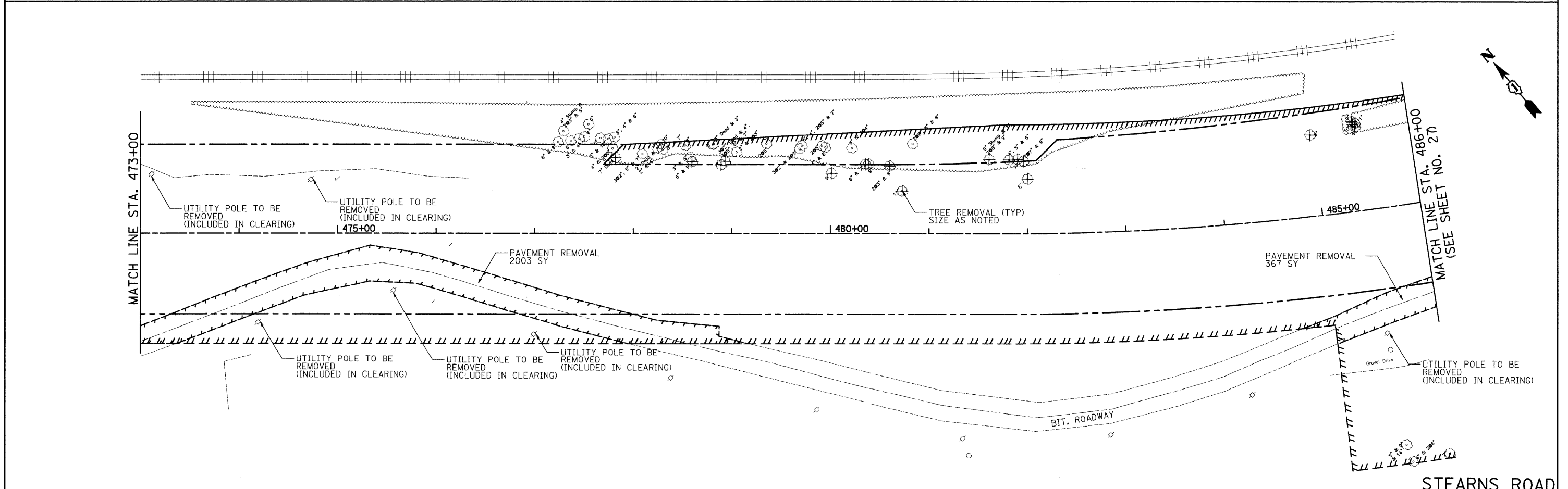

STEARNS ROAD

FILE NAME =	USER NAME = jsm	DESIGNED - JSM	REVISED -	KANE COUNTY DIVISION OF TRANSPORTATION	EXISTING CONDITION AND REMOVAL PLAN - STEARNS ROAD	F.A. RTE. 361	SECTION 06-00214-25-BR	COUNTY KANE	TOTAL SHEETS 220	SHEET NO. 26		
	PLOT SCALE = 50,0000' / IN.	DRAWN - EDS	REVISED -			SCALE: 1" = 50'	SHEET NO. 2 OF 3 SHEETS	STA. 460+00	TO STA. 486+00	CONTRACT NO. 63076		
	PLOT DATE = 3/27/2009	CHECKED - DNM	REVISED -			FED. ROAD DIST. NO. 1 ILLINOIS FED. AID PROJECT						
		DATE - 3/30/09	REVISED -									

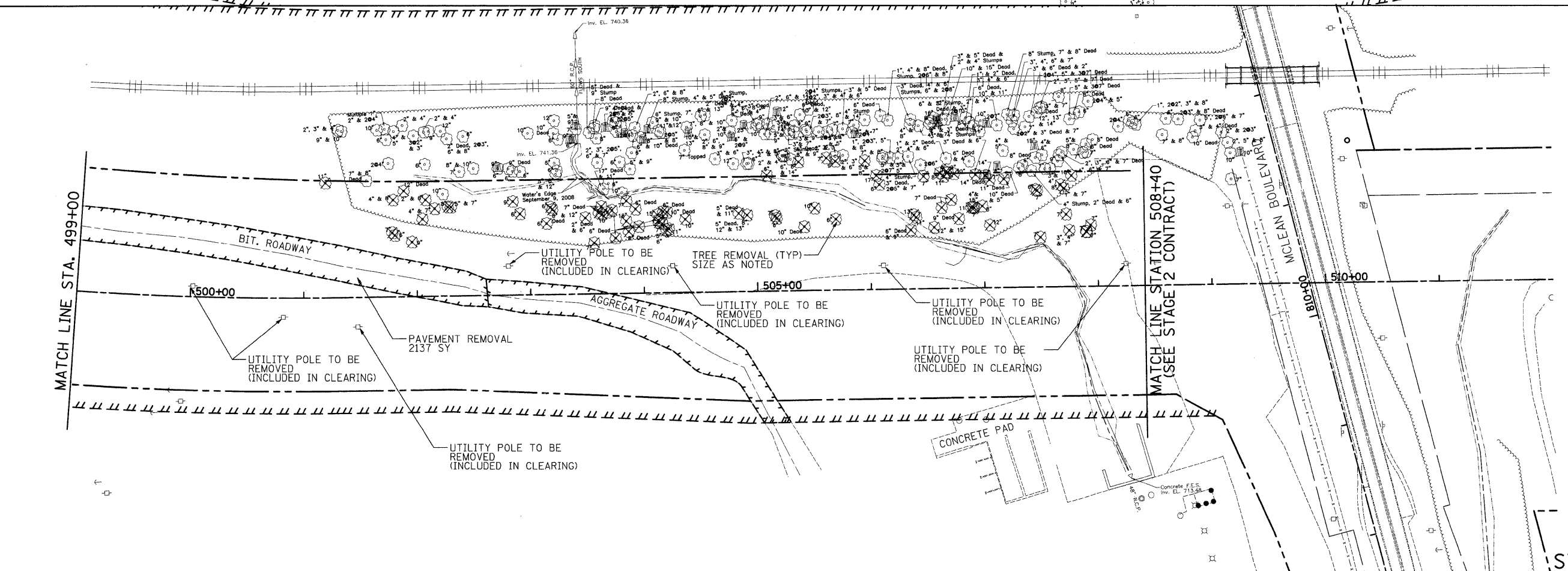
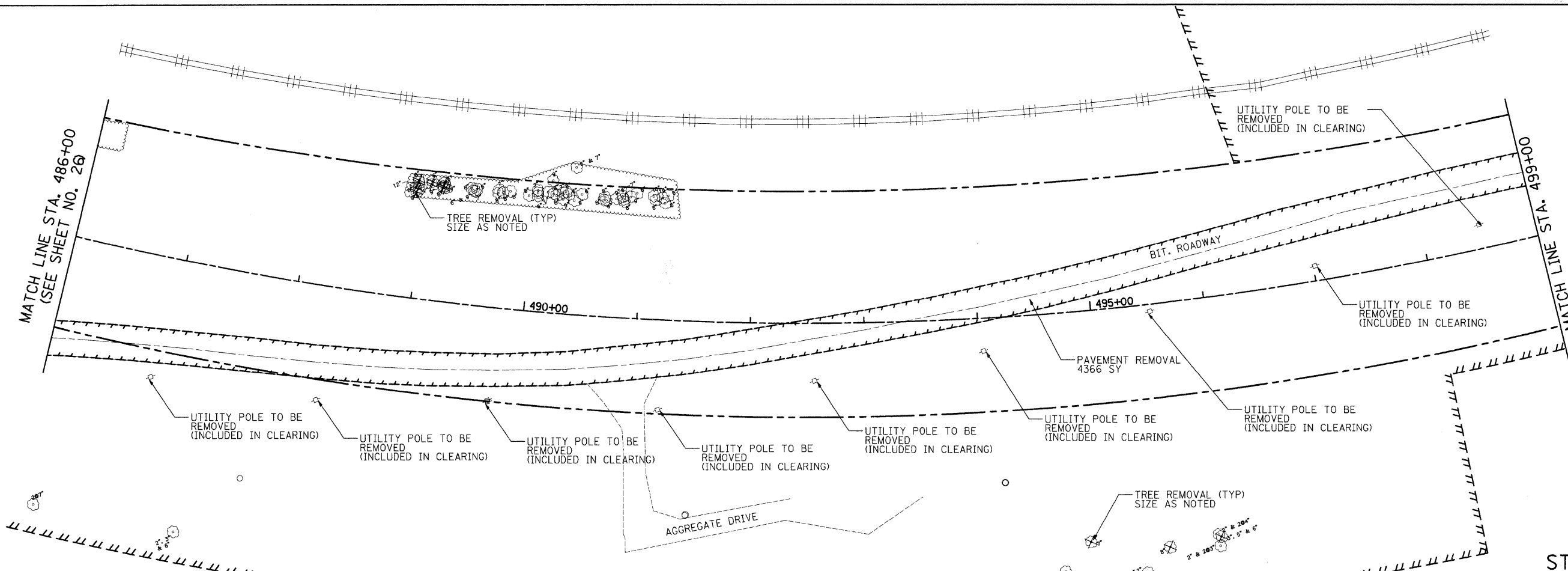

FILE NAME = 	USER NAME = jsm	DESIGNED - JSM	REVISED -	KANE COUNTY DIVISION OF TRANSPORTATION	EXISTING CONDITION AND REMOVAL PLAN - STEARNS ROAD	F.A. RTE. 361	SECTION 06-00214-25-BR	COUNTY KANE	TOTAL SHEETS 220	SHEET NO. 27			
	PLOT SCALE = 50.0000' / IN.	CHECKED - DNM	REVISED -			SCALE: 1" = 50'	SHEET NO. 3 OF 3 SHEETS	STA. 486+00 TO STA. 508+40	CONTRACT NO. 63076				
	PLOT DATE = 3/27/2009	DATE - 3/30/09	REVISED -			FED. ROAD DIST. NO. 1 ILLINOIS FED. AID PROJECT							



BEGIN RESURFACING
STA. 428+69.0

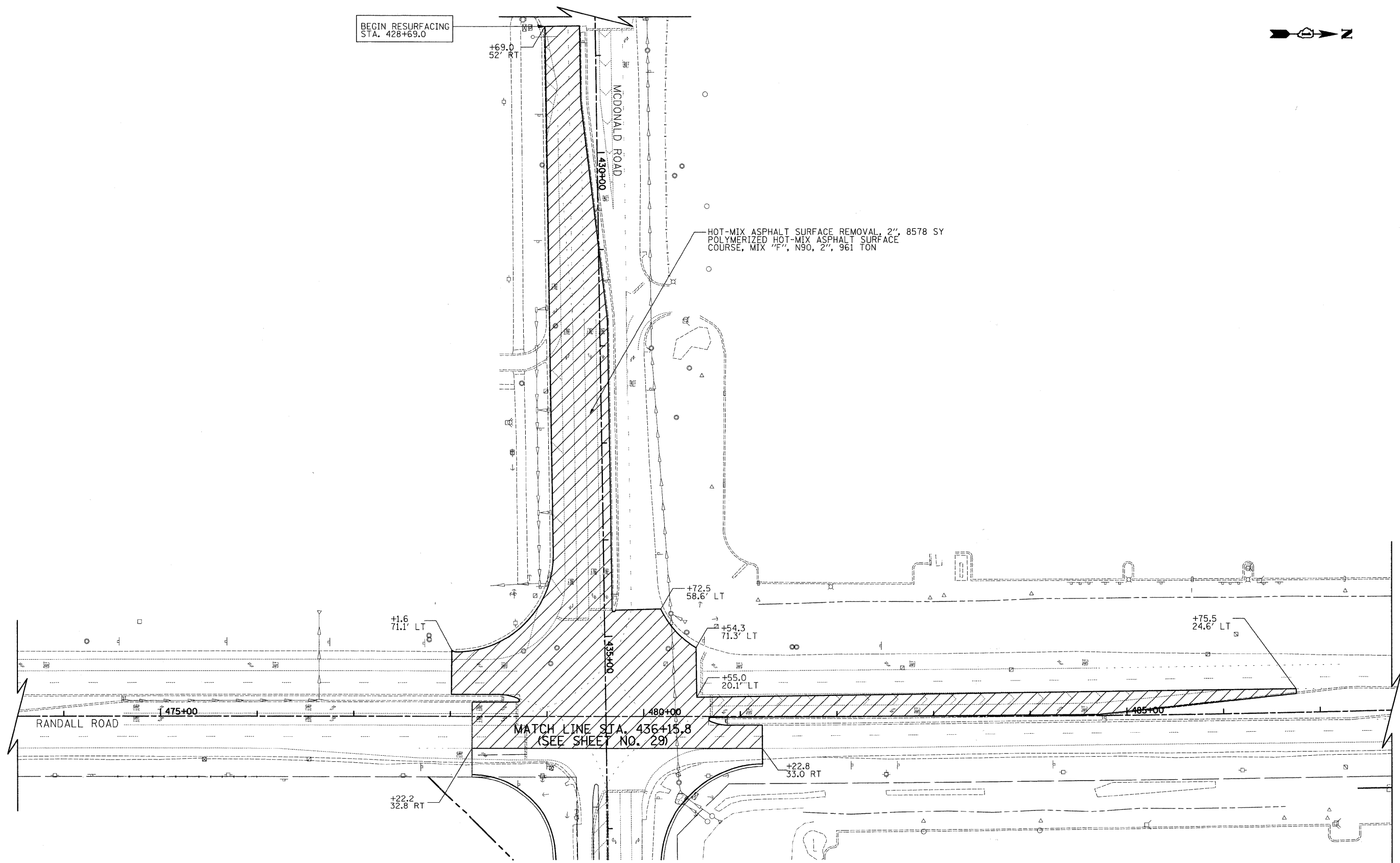

FILE NAME =		USER NAME = jam	DESIGNED - DNM	REVISED -	KANE COUNTY DIVISION OF TRANSPORTATION	RESURFACING PLAN MCDONALD ROAD AND RANDALL ROAD INTERSECTION			F.A. RTE.	SECTION	COUNTY	TOTAL SHEETS	SHEET NO.
		PLOT SCALE = 50,000.00' / IN.	DRAWN - EAD	REVISED -		361	06-00215-25-BR	KANE	220	28			
PLOT DATE = 3/27/2009	CHECKED - DNM	REVISED -	SCALE: 1" = 50' SHEET NO. 1 OF 1 SHEETS STA. TO STA.			CONTRACT NO. 63076							
DATE - 3/30/09	REVISOR -	REVISED -	FED. ROAD DIST. NO. 1 [ILLINOIS] FED. AID PROJECT										

SEE THE ALIGNMENT, TIES, BENCHMARKS AND ROW PLAN SHEET FOR CURVE INFORMATION

LEGEND

— GUTTER FLAG PITCHED OUT AT PAVEMENT CROSS SLOPE

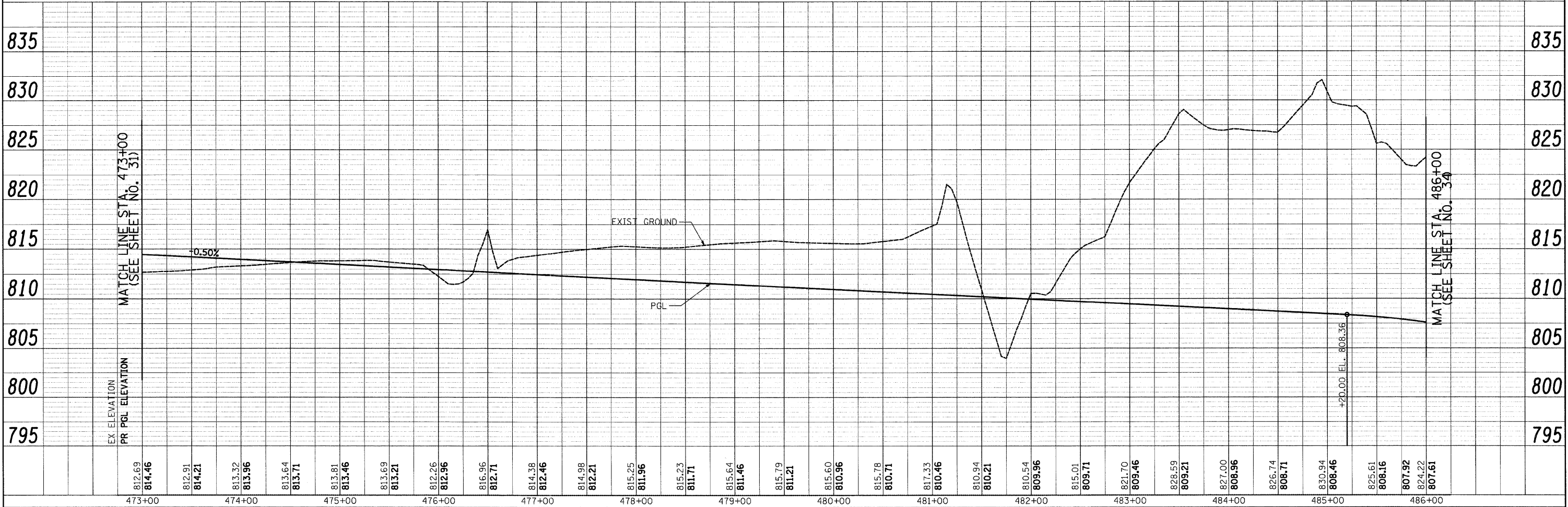
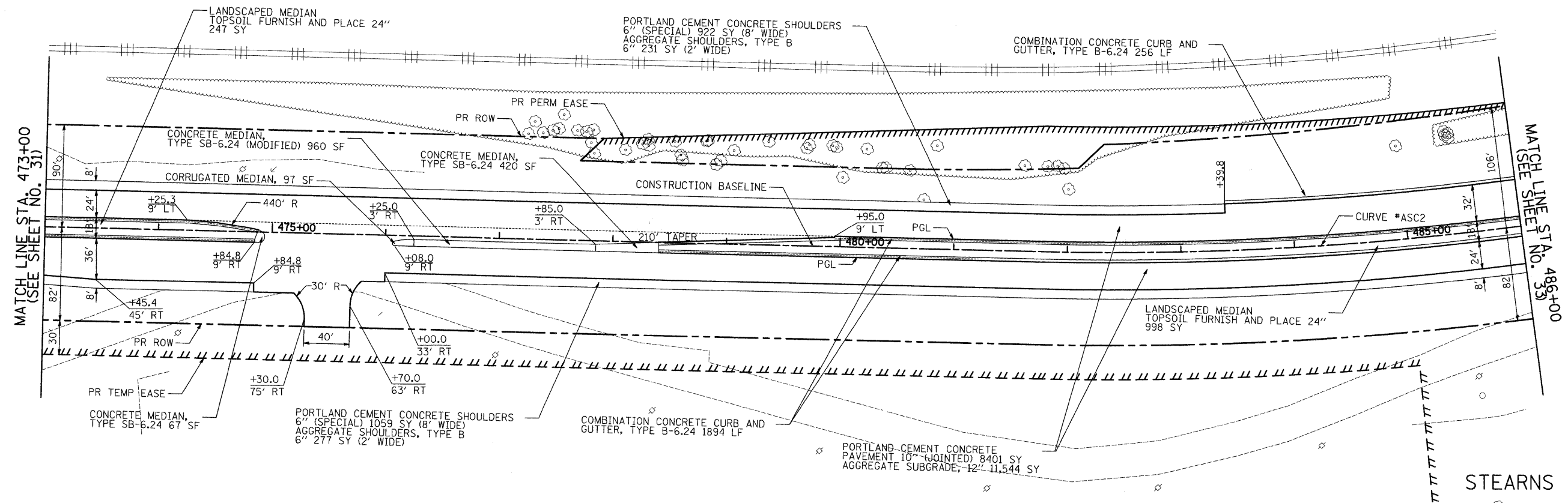
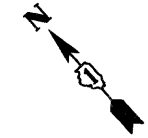

PLAN	REVISIONS	BY	DATE
NO.	NO.		
NO.	NO.		
NO.	NO.		
NO.	NO.		
NO.	NO.		
NO.	NO.		
NO.	NO.		
NO.	NO.		
NO.	NO.		
NO.	NO.		

PROFILE	REVISIONS	BY	DATE
NO.	NO.		
NO.	NO.		
NO.	NO.		
NO.	NO.		
NO.	NO.		
NO.	NO.		
NO.	NO.		
NO.	NO.		
NO.	NO.		
NO.	NO.		

FILE NAME =	USER NAME = jsm	DESIGNED - JSM	REVISED -	KANE COUNTY DIVISION OF TRANSPORTATION	PLAN & PROFILE - STEARNS ROAD	SCALE: 1"=50' SHEET NO. 4 OF 7 SHEETS STA. 473+00 TO STA. 486+00	F.A. RTE. 361	SECTION 06-00214-25-BR	COUNTY KANE	TOTAL SHEETS 220	SHEET NO. 32
PLOT SCALE = 52.0000' / IN.	CHECKED - EAD	REVISED -	CONTRACT NO. 63076								
PLOT DATE = 3/27/2009	DATE - 3/30/09	REVISED -	FED. ROAD DIST. NO. 1 ILLINOIS FED. AID PROJECT								

NOTES
 SEE STANDARD 635006-03 FOR GUARDRAIL MARKER PLACEMENT



LEGEND
 GUTTER FLAG PITCHED OUT AT PAVEMENT CROSS SLOPE

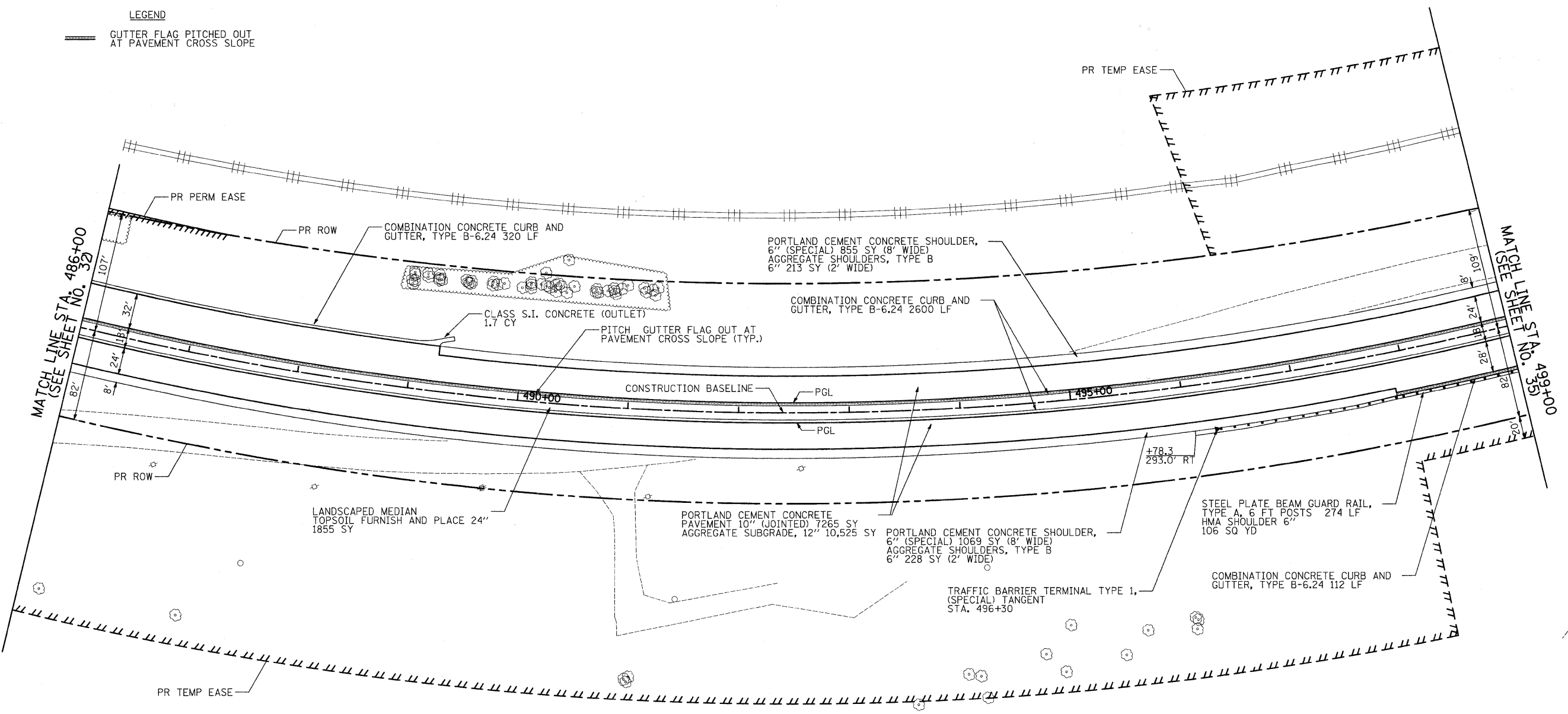

STEARNS ROAD

FILE NAME =	USER NAME = ead	DESIGNED - JSM	REVISED -	KANE COUNTY DIVISION OF TRANSPORTATION	PLAN & PROFILE - STEARNS ROAD	F.A. RTE. 361	SECTION 06-00214-25-BR	COUNTY KANE	TOTAL SHEETS 220	SHEET NO. 33
	PLOT SCALE = 50.0000' / IN.	CHECKED - EAD	REVISED -			SCALE: 1"=50'	SHEET NO. 5 OF 7 SHEETS	STA. 486+00 TO STA. 499+00	CONTRACT NO. 63076	
	PLOT DATE = 4/16/2009	DATE - 3/30/09	REVISED -			FED. ROAD DIST. NO. 1 ILLINOIS FED. AID PROJECT				

PLAN	DESIGNED	CHECKED	DATE
	PLOTTED	ALIGNED	BY
	NOTE BOOK	NO. NOTED	
		STRUCTURE NOTATIONS	

PROFILE	SURVEYED	CHECKED	DATE
	GRADES	NOTED	BY
	NOTE BOOK	NO. NOTED	
		STRUCTURE NOTATIONS	

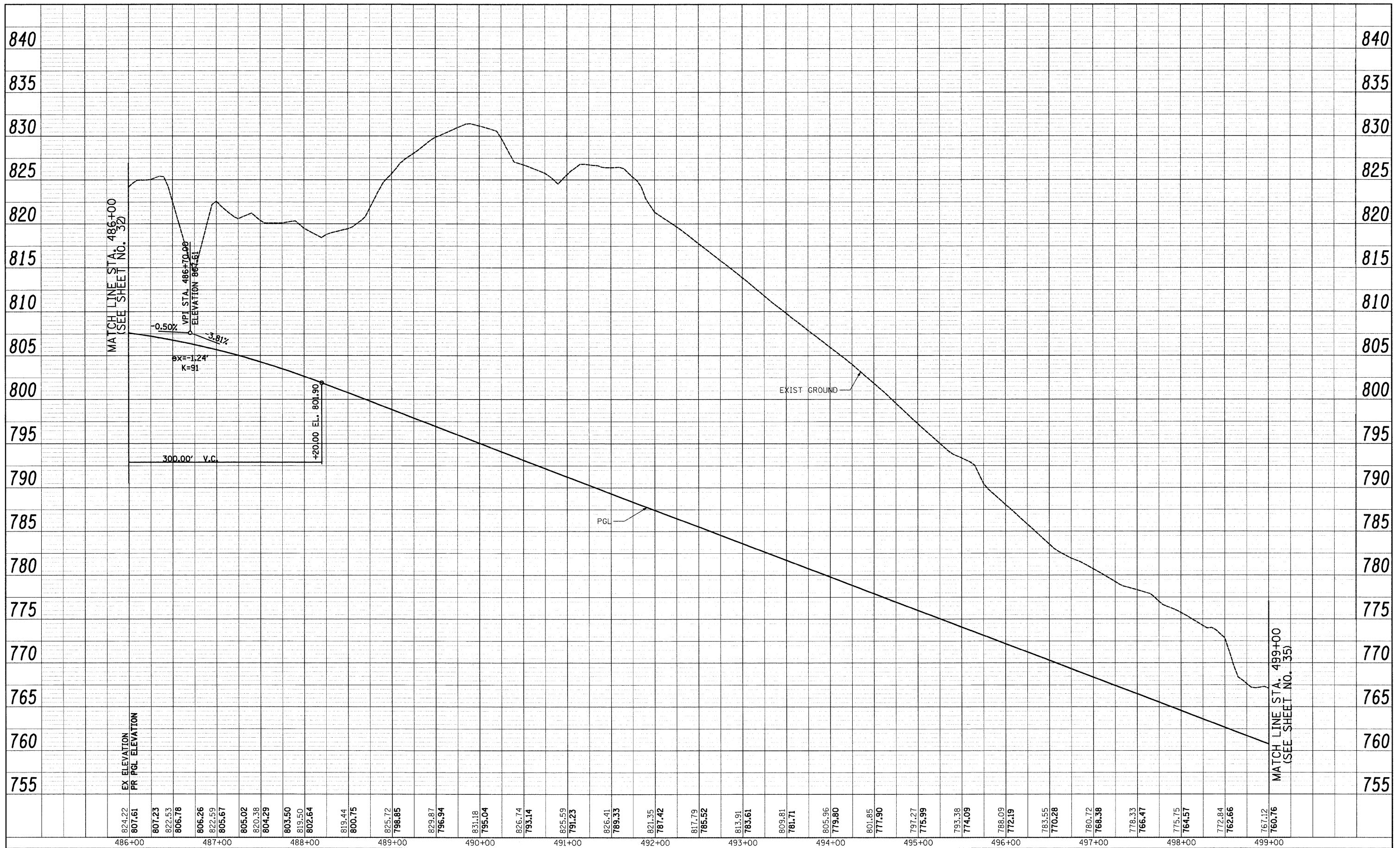

NOTES
SEE STANDARD 635006-03 FOR GUARDRAIL MARKER PLACEMENT



MATCH LINE STA. 499+00
(SEE SHEET NO. 33)

MATCH LINE STA. 499+00
(SEE SHEET NO. 34)

END RECONSTRUCTION
CONTRACT 5
STA. 508+40

STEARN'S ROAD

PLAN	SURVEYED	BY	DATE
	PLOTTED		
	CHECKED		
	REVISION		
	NO. OF REV. CHECKED		
	CADD FILE NAME		
	NO.		

PROFILE	SURVEYED	BY	DATE
	PLOTTED		
	CHECKED		
	REVISION		
	NO. OF REV. CHECKED		
	STRUCTURE NOTATIONS CHKD		
	NO.		

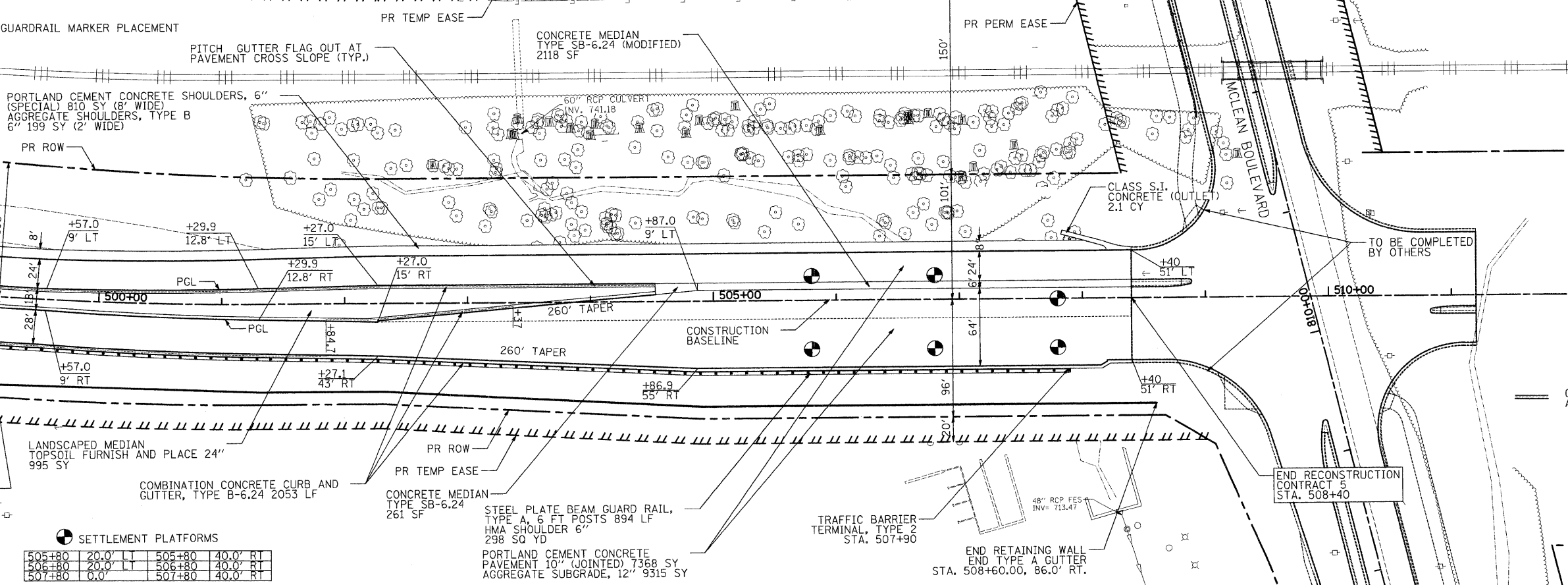

505+80	20.0'	LT	505+80	40.0'	RT
506+80	20.0'	LT	506+80	40.0'	RT
507+80	0.0'		507+80	40.0'	RT

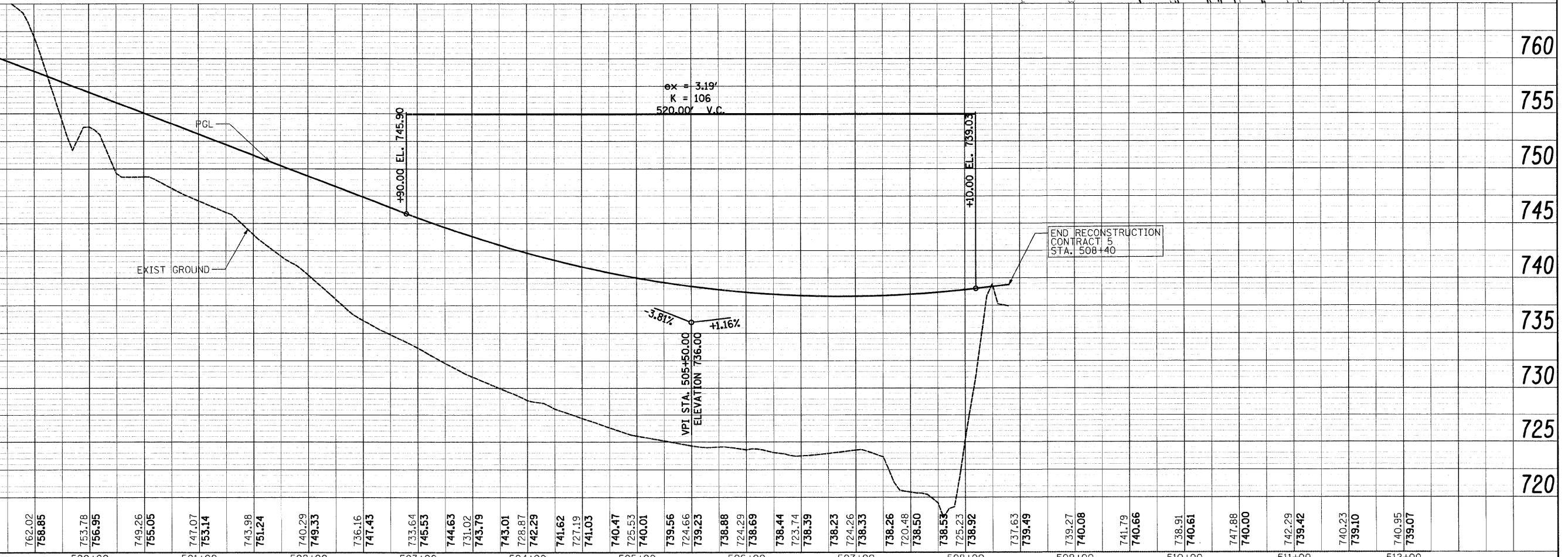

FILE NAME =	USER NAME = ead	DESIGNED - JSM	REVISED -	KANE COUNTY DIVISION OF TRANSPORTATION	PLAN & PROFILE - STEARN'S ROAD	F.A. RTE.	SECTION	COUNTY	TOTAL SHEETS	SHEET NO.
	DESIGNED - EAD	REVISED -	361			06-00214-25-BR	KANE	220	35	
PLLOT SCALE = 50.0000' / IN.	CHECKED - EAD	REVISED -	CONTRACT NO. 63076							
PLLOT DATE = 4/15/2009	DATE - 3/30/09	REVISED -	FED. ROAD DIST. NO. 1 ILLINOIS FED. AID PROJECT							
		SCALE: 1"=50'	SHEET NO. 7 OF 7 SHEETS	STA. 499+00	TO STA. 508+40					

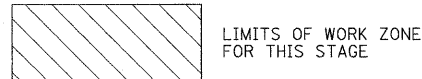

NOTE:

ALL DIAMOND SHAPE CONSTRUCTION WARNING SIGNS SHALL BE 48" X 48" UNLESS OTHERWISE NOTED

TYPE I OR TYPE II BARRICADES ARE NOT PERMITTED ON RANDALL ROAD OR STEARNS ROAD FROM STA. 434+00 TO STA. 437+00, CONTRACTOR SHALL USE DRUMS ONLY

LEGEND

- ○ ○ TYPE I OR II BARRICADES (OR DRUMS) WITH MONO-DIRECTIONAL STEADY-BURN LIGHTS @ 50' CENTERS (25' SPACING IN TAPERS, 10' SPACING IN CORNER RADII)
- ⊥ ⊥ TYPE III BARRICADE WITH FLASHING LIGHTS
- ↑ TEMPORARY TRAFFIC SIGN
- ⇨ DIRECTION OF TRAFFIC
- FLASHING AMBER BEACON

SEE IDOT STANDARD DETAIL 701701-05

END ROAD WORK
G20-2
36" X 18"

R3-8B
48" X 30"

4" WHITE SKIP DASH
(2' DASH - 6' SKIP)

REMOVE CONFLICTING PAVEMENT MARKINGS (TYP.)

4" WHITE SKIP DASH
(2' DASH - 6' SKIP)

ONLY
R3-5R
30" X 36"

REMOVE CONFLICTING PAVEMENT MARKINGS (TYP.)

LETTERS & SYMBOLS, WHITE

REMOVE CONFLICTING PAVEMENT MARKINGS

4" WHITE SKIP DASH
(2' DASH - 6' SKIP)

4" WHITE SKIP DASH
(2' DASH - 6' SKIP)

4" WHITE

REMOVE CONFLICTING PAVEMENT MARKINGS

SEE SHEET NO. 39
STEARNS ROAD MOT

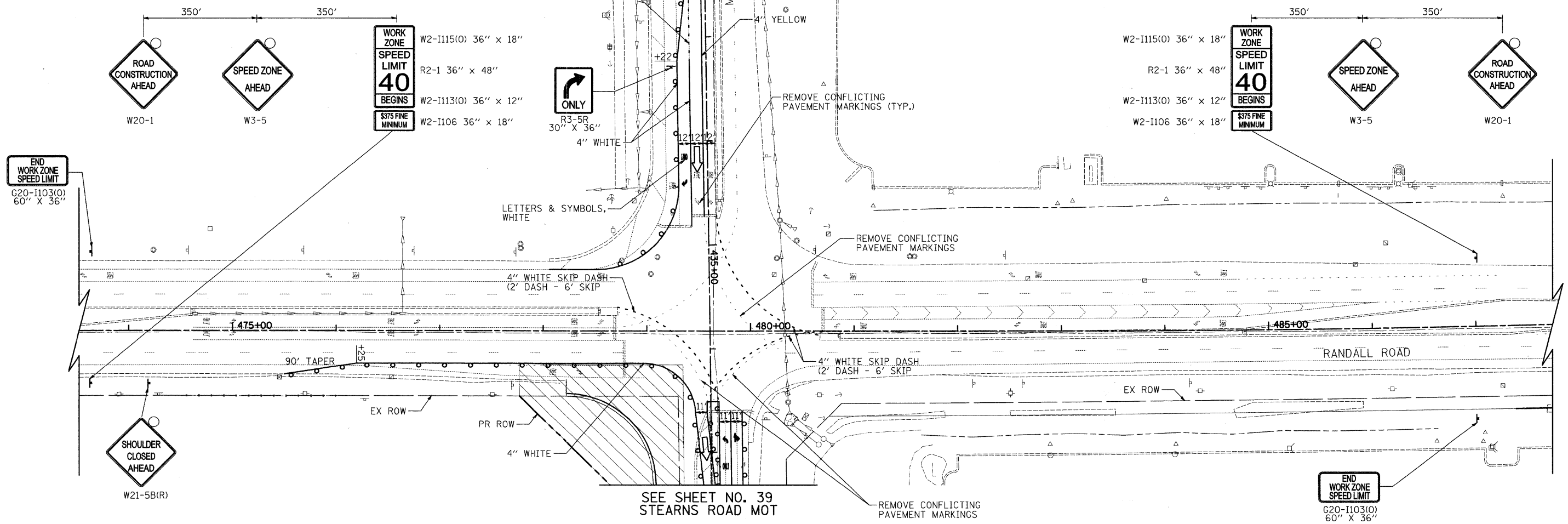

FILE NAME =	USER NAME = jsm	DESIGNED - JSM	REVISED -	KANE COUNTY DIVISION OF TRANSPORTATION	MAINTENANCE OF TRAFFIC - MCDONALD ROAD & RANDALL ROAD STAGE 2A & 2B	F.A. RTE. = 361	SECTION = 06-00214-25-BR	COUNTY = KANE	TOTAL SHEETS = 220	SHEET NO. = 38
	PLOT SCALE = 50,0000' / IN.	CHECKED - DNM	REVISED -			SCALE: 1" = 50'	SHEET NO. 2 OF 14 SHEETS	STA. TO STA. 436+00	CONTRACT NO. 63076	
PLOT DATE = 3/30/2009	DATE = 3/30/09	REVISED -	REVISED -	FED. ROAD DIST. NO. 1 ILLINOIS FED. AID PROJECT						

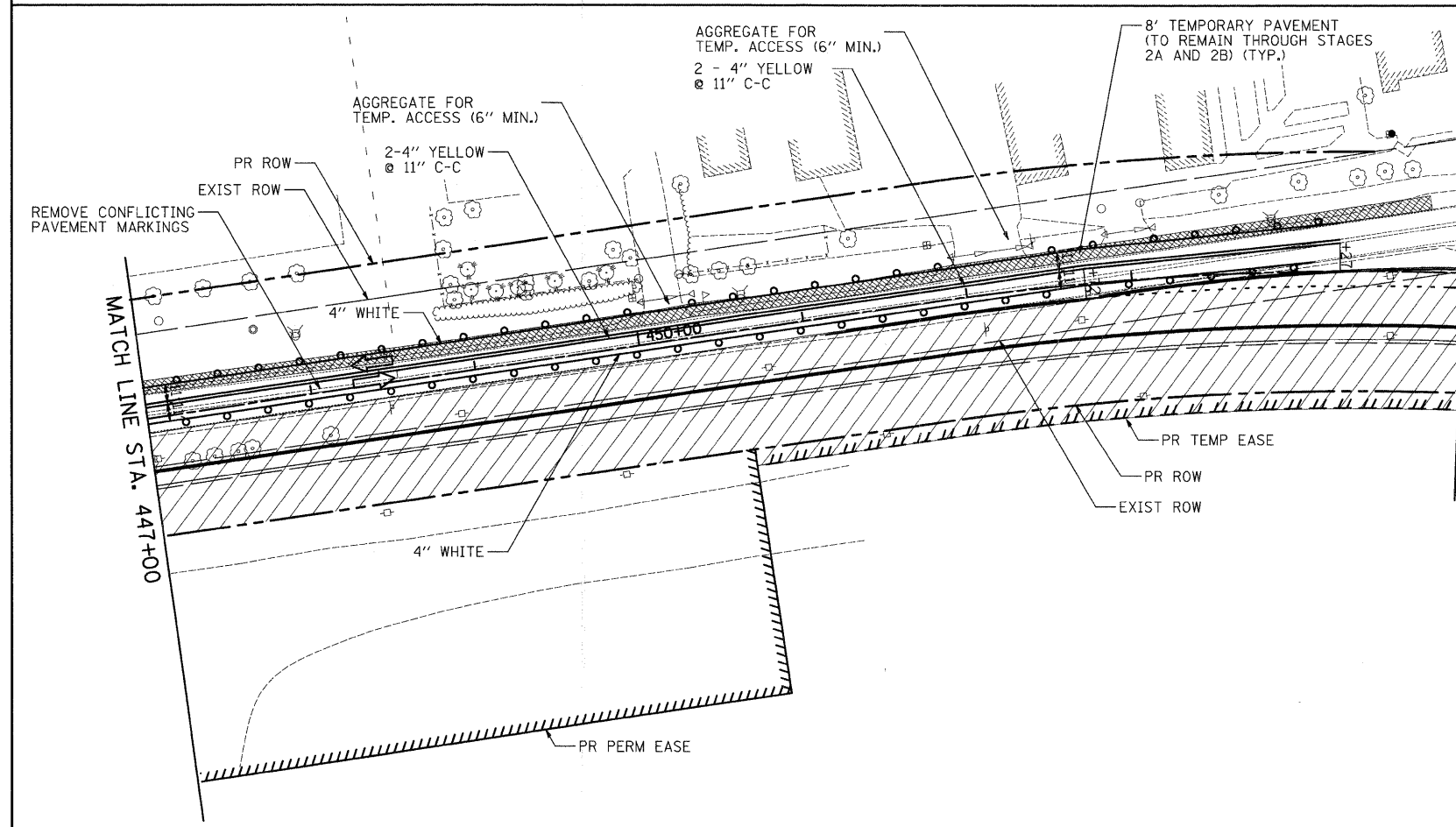
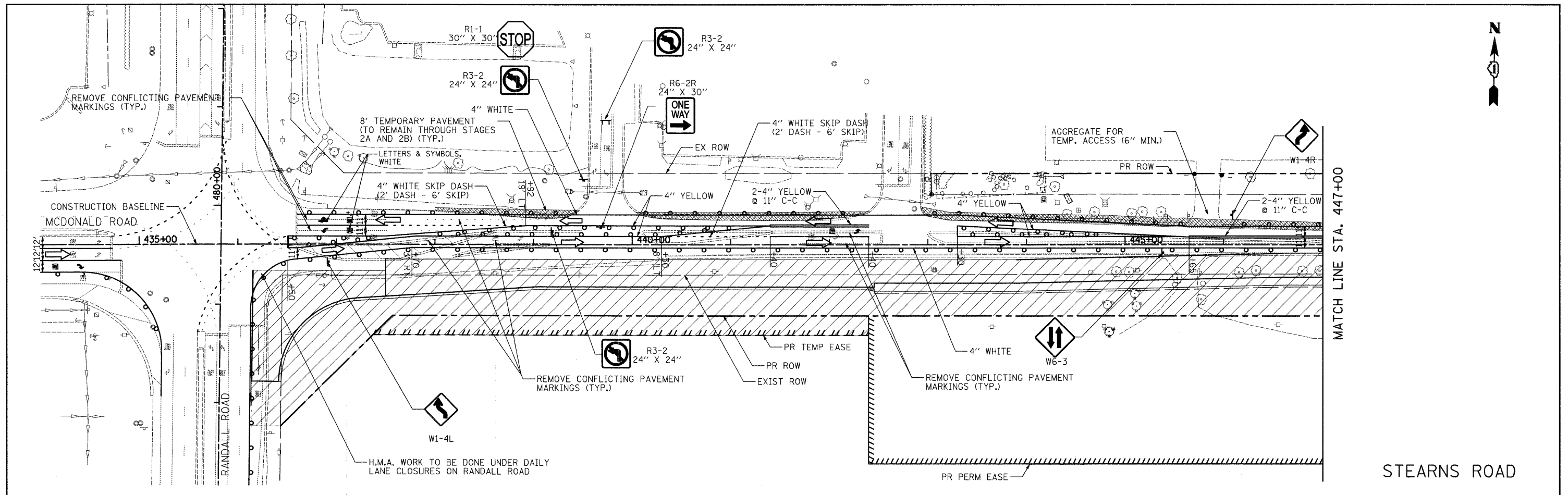

LEGEND

- ○ ○ TYPE I OR II BARRICADES (OR DRUMS) WITH MONO-DIRECTIONAL STEADY-BURN LIGHTS @ 50' CENTERS (25' SPACING IN TAPERS, 10' SPACING IN CORNER RADII)
- T T TYPE III BARRICADE WITH FLASHING LIGHTS
- ↑ ↑ TEMPORARY TRAFFIC SIGN
- ⇓ DIRECTION OF TRAFFIC

NOTE:

ALL PAVEMENT MARKINGS ON FINAL PAVEMENT SHALL BE TYPE III TAPE, OTHERWISE ALL PAVEMENT MARKINGS WILL BE TEMPORARY PAVEMENT MARKINGS

ALL DIAMOND SHAPE CONSTRUCTION WARNING SIGNS SHALL BE 48" X 48" UNLESS OTHERWISE NOTED

TYPE I OR TYPE II BARRICADES ARE NOT PERMITTED ON RANDALL ROAD OR STEARNS ROAD FROM STA. 434+00 TO STA. 437+00, CONTRACTOR SHALL USE DRUMS ONLY

STEARNS ROAD

FILE NAME =	USER NAME = jsm	DESIGNED - JSM	REVISED -	KANE COUNTY DIVISION OF TRANSPORTATION	MAINTENANCE OF TRAFFIC - STEARNS ROAD STAGE 2A & 2B		F.A. RTE.	SECTION	COUNTY	TOTAL SHEETS	SHEET NO.
		DRAWN - JSM	REVISED -		361	06-00214-25-BR	KANE	220	39		
PLOT SCALE = 50.0000' / IN.	PLOT DATE = 3/30/2009	CHECKED - DNM	DATE - 3/30/09	REVISED -	SCALE: 1" = 50'	SHEET NO. 3 OF 14 SHEETS	STA. 436+00	TO STA. 455+00	CONTRACT NO. 63076		
										FED. ROAD DIST. NO. 1 ILLINOIS FED. AID PROJECT	



LIMITS OF WORK ZONE FOR THIS STAGE

LEGEND

- ○ ○ TYPE I OR II BARRICADES (OR DRUMS) WITH MONO-DIRECTIONAL STEADY-BURN LIGHTS @ 50' CENTERS (25' SPACING IN TAPERS, 10' SPACING IN CORNER RADII)
- ⊥ ⊥ TYPE III BARRICADE WITH FLASHING LIGHTS
- ↑ TEMPORARY TRAFFIC SIGN
- ⇄ DIRECTION OF TRAFFIC
- FLASHING AMBER BEACON

NOTE:

ALL PAVEMENT MARKINGS ON FINAL PAVEMENT SHALL BE TYPE III TAPE, OTHERWISE ALL PAVEMENT MARKINGS WILL BE TEMPORARY PAVEMENT MARKINGS

ALL DIAMOND SHAPE CONSTRUCTION WARNING SIGNS SHALL BE 48" X 48" UNLESS OTHERWISE NOTED

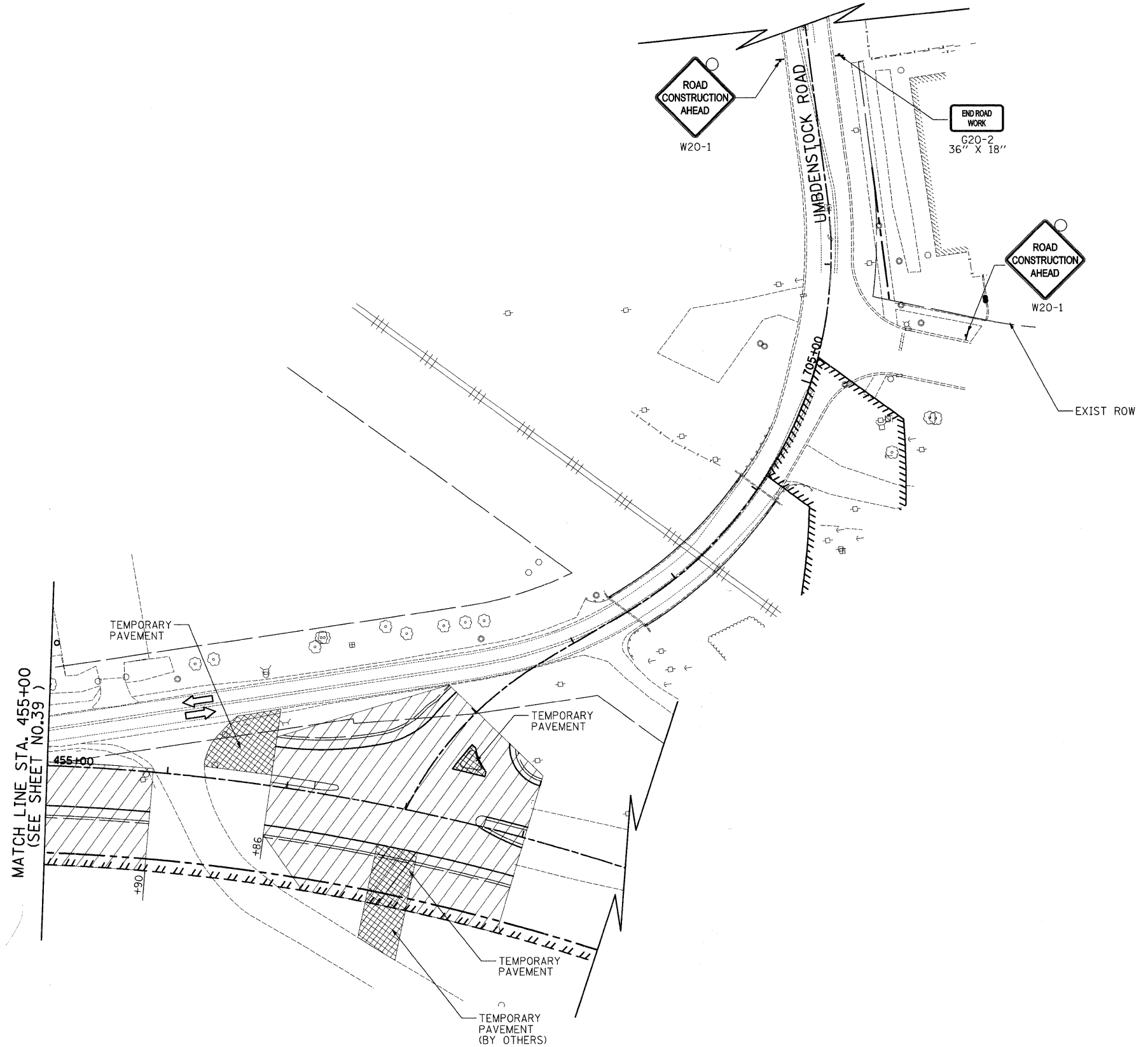

STEARNS ROAD

FILE NAME = 	USER NAME = jsm	DESIGNED - JSM	REVISED -	KANE COUNTY DIVISION OF TRANSPORTATION	MAINTENANCE OF TRAFFIC - STEARNS ROAD STAGE 2A	F.A. RTE. 361	SECTION 06-00214-25-BR	COUNTY KANE	TOTAL SHEETS 220	SHEET NO. 40
	PLOT SCALE = 50,0000' / IN.	CHECKED - DNM	REVISED -			SCALE: 1" = 50'	SHEET NO. 4 OF 14 SHEETS	STA. 455+00 TO STA.	CONTRACT NO. 63076 <small>FED. ROAD DIST. NO. 1 ILLINOIS FED. AID PROJECT</small>	
PLOT DATE = 3/30/2009	DATE - 3/30/09	REVISED -	REVISED -							



LEGEND

- ○ ○ TYPE I OR II BARRICADES (OR DRUMS) WITH MONO-DIRECTIONAL STEADY-BURN LIGHTS @ 50' CENTERS (25' SPACING IN TAPERS, 10' SPACING IN CORNER RADII)
- ⌌ ⌌ ⌌ TYPE III BARRICADE WITH FLASHING LIGHTS
- ↑ TEMPORARY TRAFFIC SIGN ON PERMANENT SUPPORT
- ⬇ TEMPORARY TRAFFIC SIGNAL
- ⇨ DIRECTION OF TRAFFIC
- FLASHING AMBER BEACON

NOTE:

ALL PAVEMENT MARKINGS ON FINAL PAVEMENT SHALL BE TYPE III TAPE, OTHERWISE ALL PAVEMENT MARKINGS WILL BE TEMPORARY PAVEMENT MARKINGS

STATIONS DENOTED WITH • ARE OFF OF EXISTING MC DONALD ROAD ALIGNMENT

ALL DIAMOND SHAPE CONSTRUCTION WARNING SIGNS SHALL BE 48" X 48" UNLESS OTHERWISE NOTED

EXISTING W11-10 (TRUCK CROSSING) SIGNS SHALL REMAIN IN PLACE TO WARN MOTORISTS ABOUT TRUCKS ENTERING AND LEAVING HIGHWAY, IF THE EXISTING SIGNS ARE REMOVED FOR ANY REASON, TEMPORARY BARRICADE MOUNTED W11-10 SHALL BE INSTALL IN PLACE.

FOLLOW STANDARD 701316 FOR TEMPORARY SIGNAL AND SIGNING FOR TEMPORARY SIGNAL

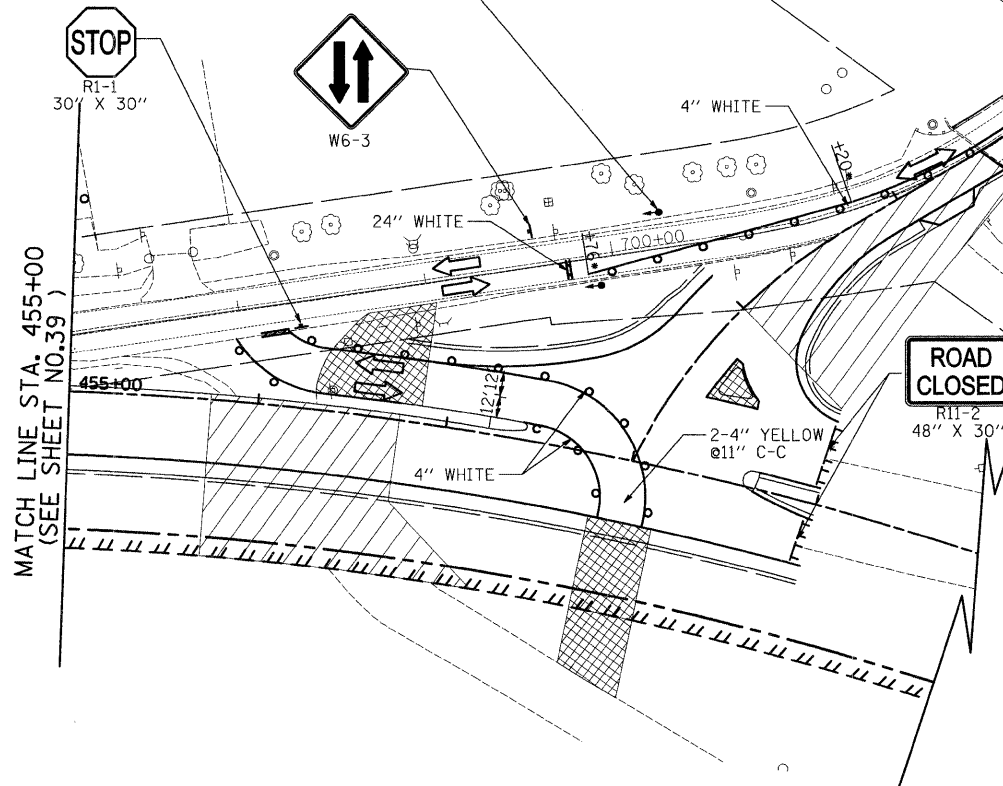

FOLLOW STANDARD 701316 FOR TEMPORARY SIGNAL AND SIGNING FOR ONE WAY TRAFFIC CONTROL. PLAN SHEET DOES NOT SHOW THE COMPLETE STANDARD, ALTHOUGH IT SHALL BE FOLLOWED. TEMPORARY RUMBLE STRIPS ARE NOT REQUIRED. CONTRACTOR MUST USE TEMPORARY PORTABLE BRIDGE TRAFFIC SIGNALS PER IDOT CHECK SHEET #23.



STEARNS ROAD

FILE NAME = 	USER NAME = jsm DESIGNED - JSM DRAWN - JSM CHECKED - DNM PLOT DATE = 3/30/2009	REVISED - REVISED - REVISED - REVISED -	KANE COUNTY DIVISION OF TRANSPORTATION	MAINTENANCE OF TRAFFIC - STEARNS ROAD STAGE 2B	F.A. RTE. 361 SECTION 06-00214-25-BR COUNTY KANE TOTAL SHEETS 220 SHEET NO. 41 CONTRACT NO. 63076
	SCALE: 1" = 50' SHEET NO. 5 OF 14 SHEETS STA. 455+00 TO STA.	FED. ROAD DIST. NO. 1 ILLINOIS FED. AID PROJECT			



LIMITS OF WORK ZONE FOR THIS STAGE

LEGEND

- ○ ○ TYPE I OR II BARRICADES (OR DRUMS) WITH MONO-DIRECTIONAL STEADY-BURN LIGHTS @ 50' CTRS (25' SPACING IN TAPERS, 10' SPACING IN CORNER RADII)
- TT TYPE III BARRICADE WITH FLASHING LIGHTS
- ↑ TEMPORARY TRAFFIC SIGN ON PERMANENT SUPPORT
- ➔ DIRECTION OF TRAFFIC
- FLASHING AMBER BEACON

NOTE:

ALL DIAMOND SHAPE CONSTRUCTION WARNING SIGNS SHALL BE 48" X 48" UNLESS OTHERWISE NOTED

TYPE I OR TYPE II BARRICADES ARE NOT PERMITTED ON RANDALL ROAD OR STEARNS ROAD FROM STA. 434+00 TO STA. 437+00, CONTRACTOR SHALL USE DRUMS ONLY

SEE IDOT STANDARD DETAIL 701701-05

END ROAD WORK
G20-2
36" X 18"

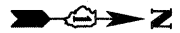

R3-5L
30" X 36"
ONLY

R3-5R
30" X 36"
4" WHITE

R3-5R
30" X 36"
4" WHITE SKIP DASH
(2' DASH - 6' SKIP)

REMOVE CONFLICTING PAVEMENT MARKINGS (TYP.)

REMOVE CONFLICTING PAVEMENT MARKINGS

REMOVE CONFLICTING PAVEMENT MARKINGS

REMOVE CONFLICTING PAVEMENT MARKINGS

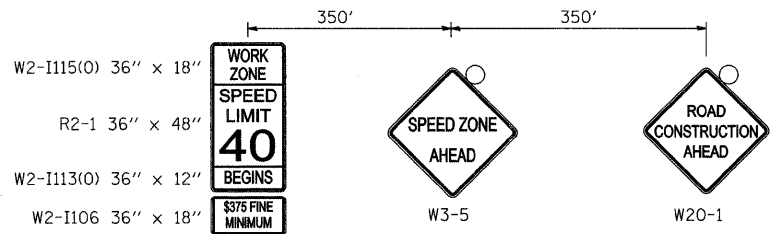
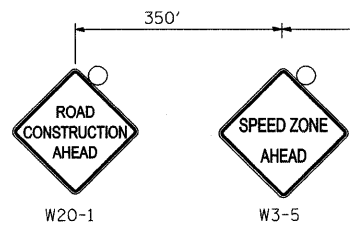

END WORK ZONE SPEED LIMIT
G20-1103(0)
60" X 36"

END WORK ZONE SPEED LIMIT
G20-1103(0)
60" X 36"

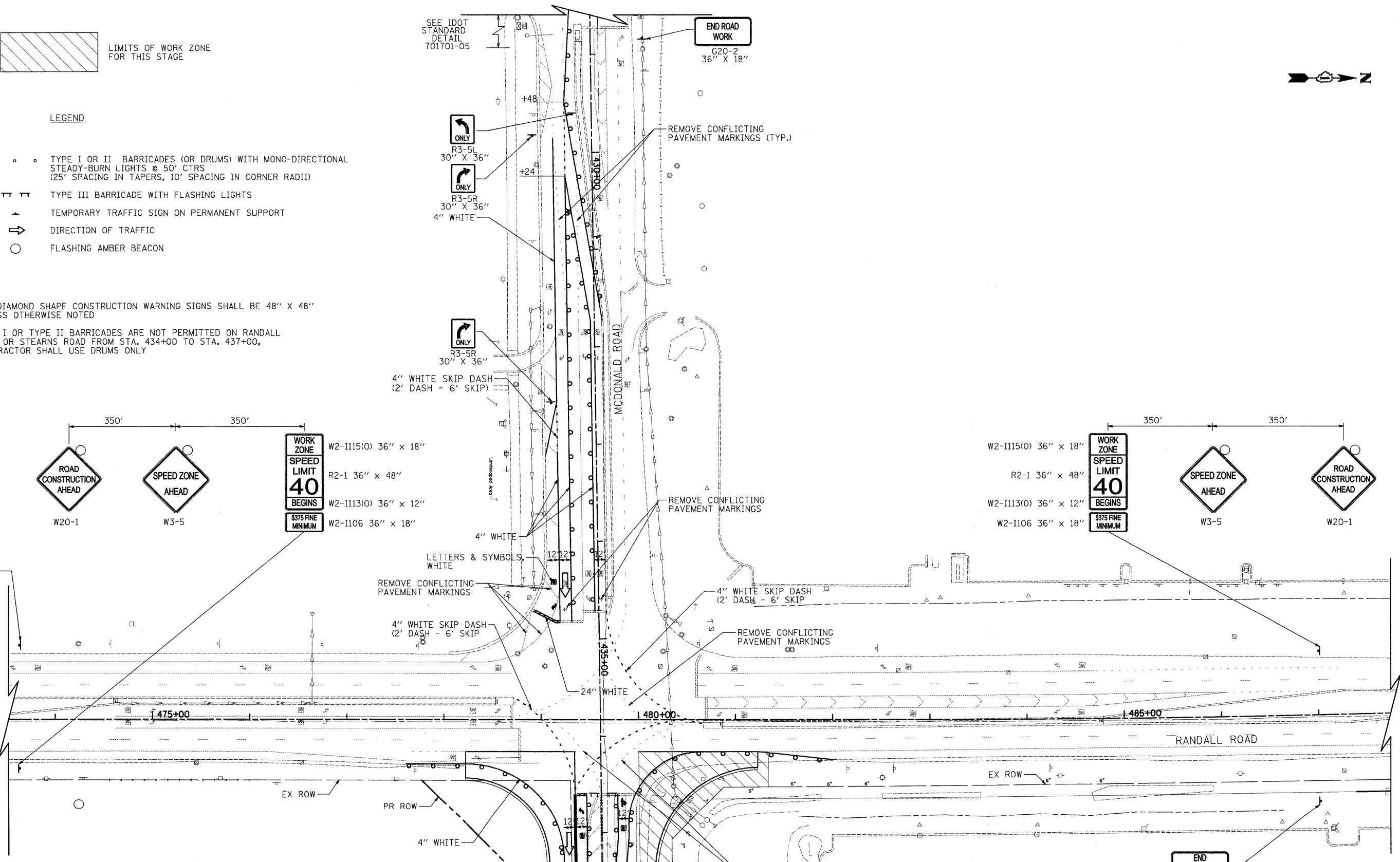

FILE NAME =	USER NAME = jsm	DESIGNED - JSM	REVISED -	KANE COUNTY DIVISION OF TRANSPORTATION	MAINTENANCE OF TRAFFIC - MCDONALD ROAD & RANDALL ROAD STAGE 3A & 3B	F.A. RTE.	SECTION	COUNTY	TOTAL SHEETS	SHEET NO.
	PLOT SCALE = 50.0000' / IN.	DRAWN - JSM	REVISED -			361	06-00214-25-BR	KANE	220	42
PLOT DATE = 3/30/2009	CHECKED - DNM	DATE - 3/30/09	REVISED -	SCALE: 1" = 50'	SHEET NO. 6 OF 14 SHEETS	STA. TO STA. 436+00	FED. ROAD DIST. NO. 1 ILLINOIS FED. AID PROJECT			
						CONTRACT NO. 63076				

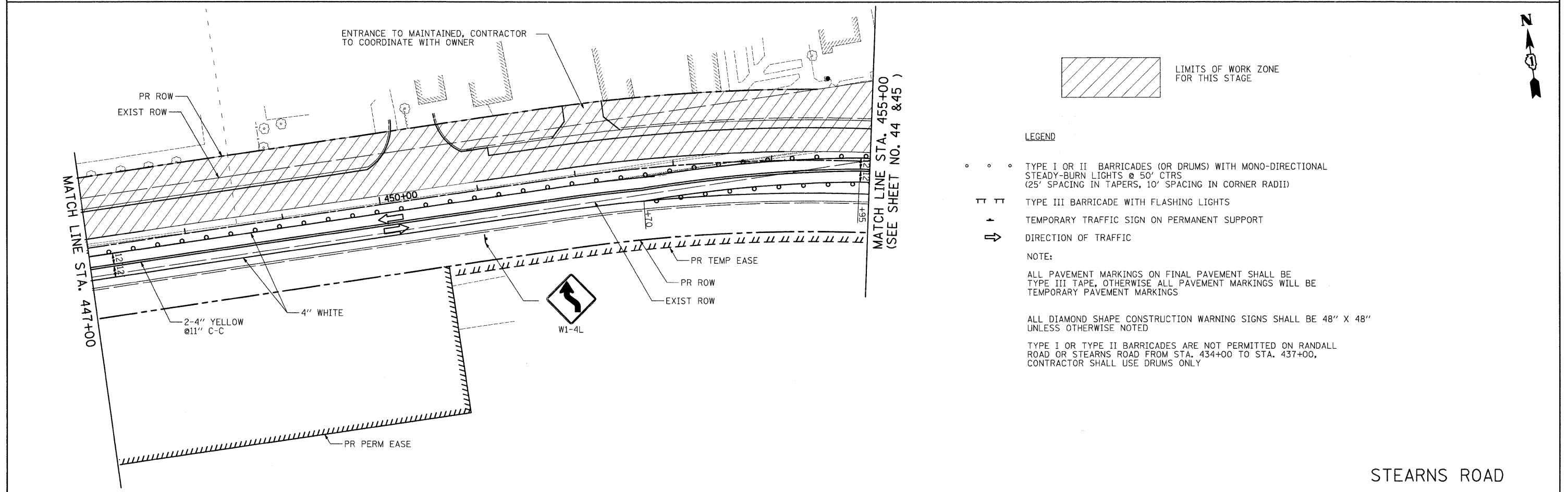
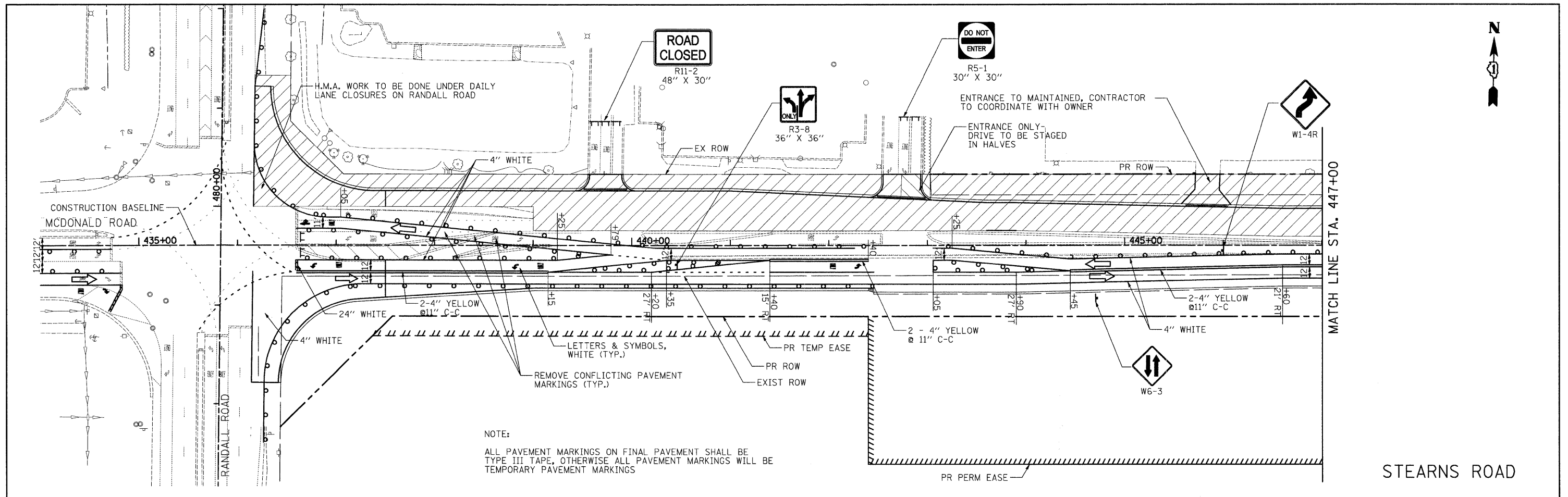

FILE NAME =	USER NAME = jsm	DESIGNED - JSM	REVISED -	KANE COUNTY DIVISION OF TRANSPORTATION	MAINTENANCE OF TRAFFIC - STEARNS ROAD STAGE 3A & 3B			F.A. RTE.	SECTION	COUNTY	TOTAL SHEETS	SHEET NO.	
	PLOT SCALE = 50,0000' / IN.	DRAWN - JSM	REVISED -		361	06-00214-25-BR	KANE	220	43	CONTRACT NO. 63076			
	PLOT DATE = 3/30/2009	CHECKED - DNM	REVISED -		SCALE: 1" = 50'			SHEET NO. 7 OF 14 SHEETS			STA. 436+00 TO STA. 455+00		FED. ROAD DIST. NO. 1 ILLINOIS FED. AID PROJECT
		DATE - 3/30/09	REVISED -										



LEGEND

- ○ ○ TYPE I OR II BARRICADES (OR DRUMS) WITH MONO-DIRECTIONAL STEADY-BURN LIGHTS @ 50' CENTERS (25' SPACING IN TAPERS, 10' SPACING IN CORNER RADII)
- ⊥ ⊥ TYPE III BARRICADE WITH FLASHING LIGHTS
- ↑ TEMPORARY TRAFFIC SIGN ON PERMANENT SUPPORT
- ⊥ TEMPORARY TRAFFIC SIGNAL
- ⇨ DIRECTION OF TRAFFIC
- FLASHING AMBER BEACON

NOTE:

ALL PAVEMENT MARKINGS ON FINAL PAVEMENT SHALL BE TYPE III TAPE, OTHERWISE ALL PAVEMENT MARKINGS WILL BE TEMPORARY PAVEMENT MARKINGS

STATIONS DENOTED WITH • ARE OFF OF EXISTING MC DONALD ROAD ALIGNMENT

ALL DIAMOND SHAPE CONSTRUCTION WARNING SIGNS SHALL BE 48" X 48" UNLESS OTHERWISE NOTED

EXISTING W11-10 (TRUCK CROSSING) SIGNS SHALL REMAIN IN PLACE TO WARN MOTORISTS ABOUT TRUCKS ENTERING AND LEAVING HIGHWAY, IF THE EXISTING SIGNS ARE REMOVED FOR ANY REASON, TEMPORARY BARRICADE MOUNTED W11-10 SHALL BE INSTALL IN PLACE.

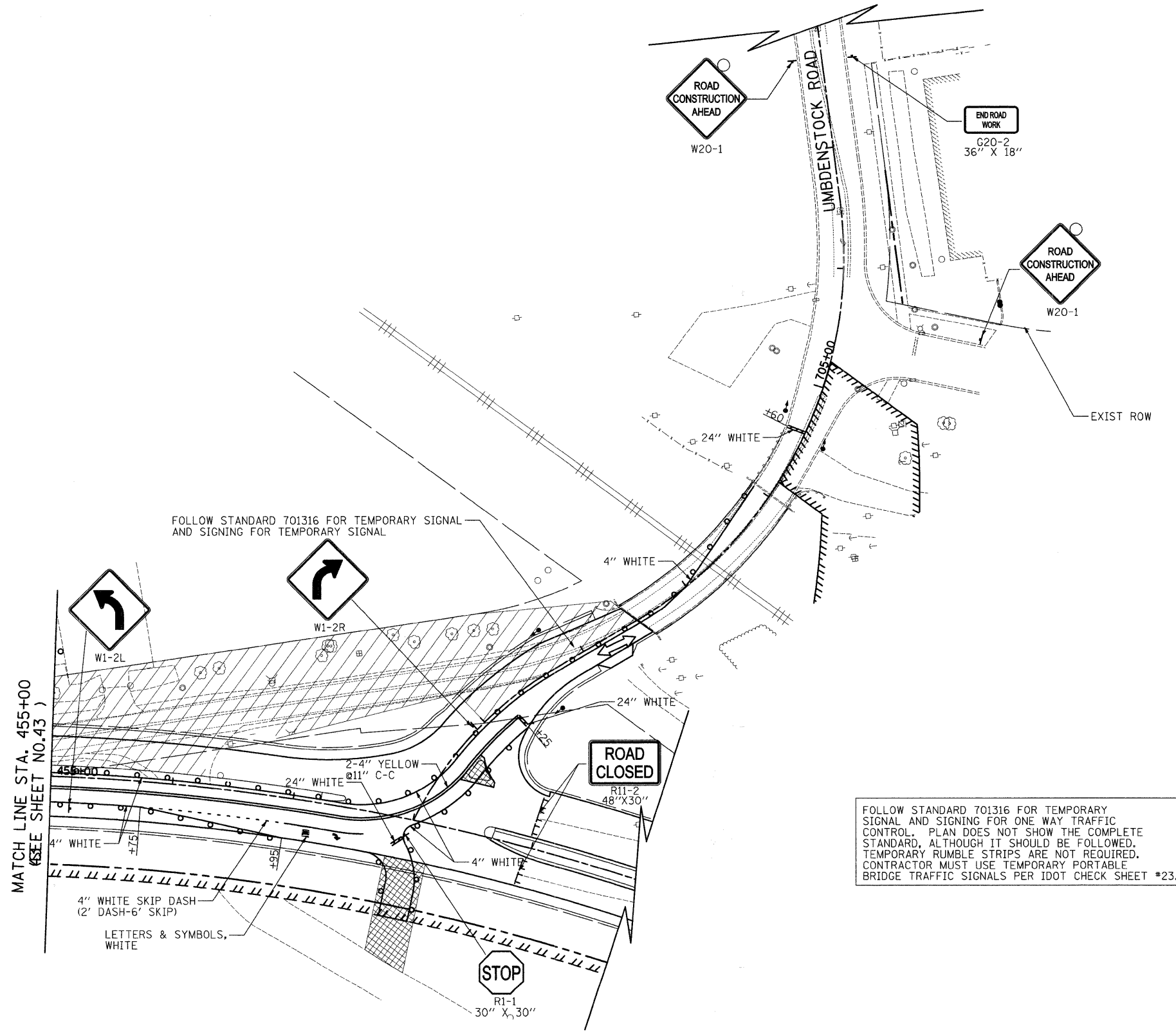

FOLLOW STANDARD 701316 FOR TEMPORARY SIGNAL AND SIGNING FOR ONE WAY TRAFFIC CONTROL. PLAN DOES NOT SHOW THE COMPLETE STANDARD, ALTHOUGH IT SHOULD BE FOLLOWED. TEMPORARY RUMBLE STRIPS ARE NOT REQUIRED. CONTRACTOR MUST USE TEMPORARY PORTABLE BRIDGE TRAFFIC SIGNALS PER IDOT CHECK SHEET #23.

STEARNS ROAD

FILE NAME = 	USER NAME = jsm	DESIGNED - JSM	REVISED -	KANE COUNTY DIVISION OF TRANSPORTATION	MAINTENANCE OF TRAFFIC - STEARNS ROAD STAGE 3A			F.A. RTE. 361	SECTION 06-00214-25-BR	COUNTY KANE	TOTAL SHEETS 220	SHEET NO. 44
	PLOT SCALE = 50,0000' / IN.	CHECKED - DNM	DATE - 3/30/09		REVISED -	SCALE: 1" = 50'	SHEET NO. 8 OF 14 SHEETS	STA. 455+00 TO STA.	CONTRACT NO. 63076			
PLOT DATE = 3/30/2009	DATE - 3/30/09	REVISED -	REVISED -				FED. ROAD DIST. NO. 1 ILLINOIS FED. AID PROJECT					



LEGEND

- ○ ○ TYPE I OR II BARRICADES (OR DRUMS) WITH MONO-DIRECTIONAL STEADY-BURN LIGHTS @ 50' CTRS (25' SPACING IN TAPERS, 10' SPACING IN CORNER RADII)
- ⊥ ⊥ TYPE III BARRICADE WITH FLASHING LIGHTS
- ↑ TEMPORARY TRAFFIC SIGN ON PERMANENT SUPPORT
- ⇨ DIRECTION OF TRAFFIC
- FLASHING AMBER BEACON

NOTE:

ALL PAVEMENT MARKINGS ON FINAL PAVEMENT SHALL BE TYPE III TAPE, OTHERWISE ALL PAVEMENT MARKINGS WILL BE TEMPORARY PAVEMENT MARKINGS

ALL DIAMOND SHAPE CONSTRUCTION WARNING SIGNS SHALL BE 48" X 48" UNLESS OTHERWISE NOTED

EXISTING W11-10 (TRUCK CROSSING) SIGNS SHALL REMAIN IN PLACE TO WARN MOTORISTS ABOUT TRUCKS ENTERING AND LEAVING HIGHWAY, IF THE EXISTING SIGNS ARE REMOVED FOR ANY REASON, TEMPORARY BARRICADE MOUNTED W11-10 SHALL BE INSTALL IN PLACE.

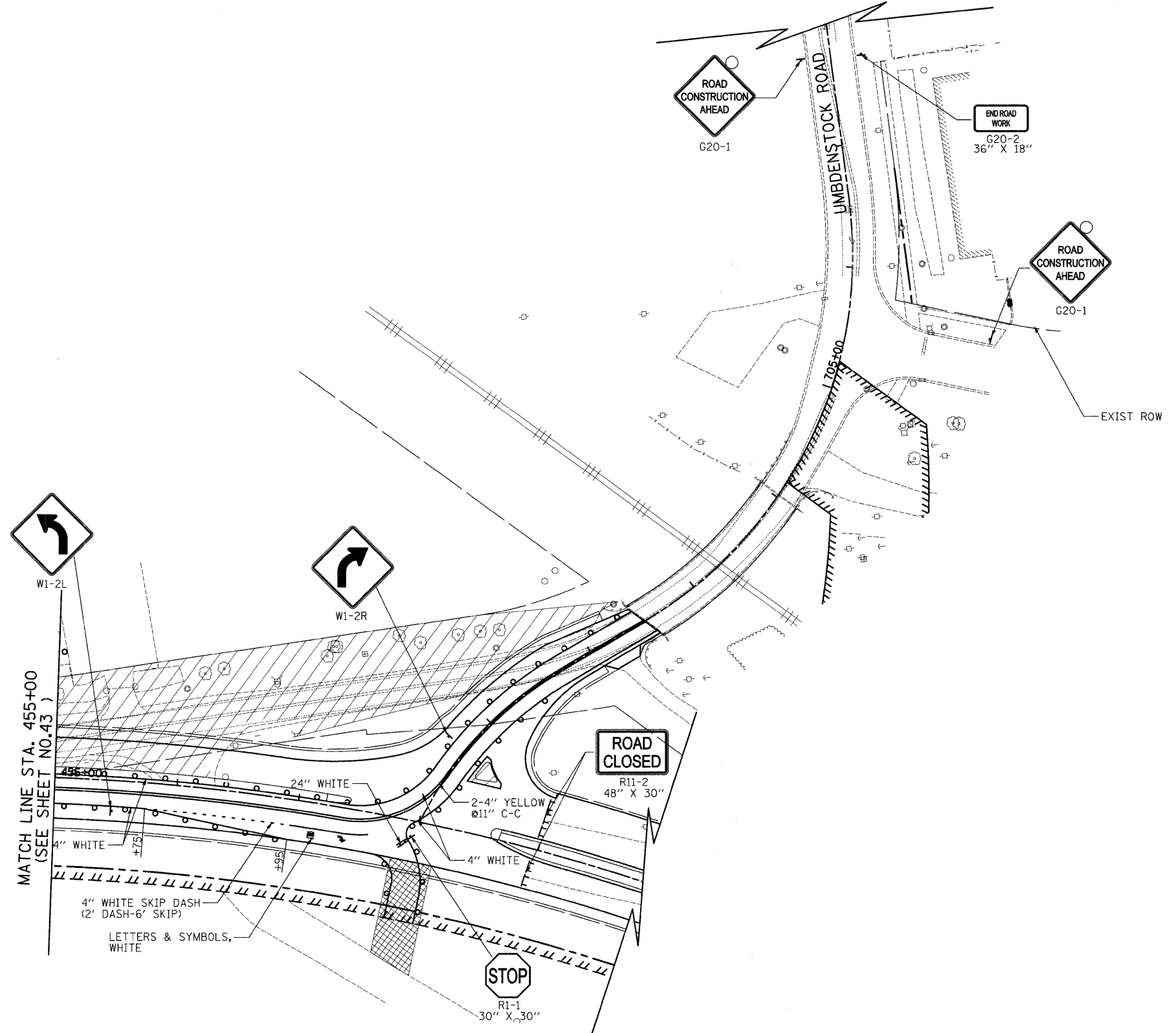

STEARNS ROAD

FILE NAME = 	USER NAME = jsm DESIGNED - JSM DRAWN - JSM CHECKED - DNM PLOT DATE = 3/30/2009	REVISED - REVISED - REVISED - REVISED -	KANE COUNTY DIVISION OF TRANSPORTATION	MAINTENANCE OF TRAFFIC - STEARNS ROAD STAGE 3B		F.A. RTE. 361 SECTION 06-00214-25-BR COUNTY KANE TOTAL SHEETS 220 SHEET NO. 45 CONTRACT NO. 63076
	SCALE: 1" = 50' SHEET NO. 9 OF 14 SHEETS STA. 455+00 TO STA.			FED. ROAD DIST. NO. 1 ILLINOIS FED. AID PROJECT		



LEGEND

- ○ ○ TYPE I OR II BARRICADES (OR DRUMS) WITH MONO-DIRECTIONAL STEADY-BURN LIGHTS @ 50' CTRS (25' SPACING IN TAPERS, 10' SPACING IN CORNER RADII)
- ⊥ ⊥ TYPE III BARRICADE WITH FLASHING LIGHTS
- ↑ TEMPORARY TRAFFIC SIGN ON PERMANENT SUPPORT
- DIRECTION OF TRAFFIC
- FLASHING AMBER BEACON

NOTE:

ALL DIAMOND SHAPE CONSTRUCTION WARNING SIGNS SHALL BE 48" X 48" UNLESS OTHERWISE NOTED
 TYPE I OR TYPE II BARRICADES ARE NOT PERMITTED ON RANDALL ROAD OR STEARNS ROAD FROM STA. 434+00 TO STA. 437+00, CONTRACTOR SHALL USE DRUMS ONLY

SEE IDOT STANDARD DETAIL 701701-05

END ROAD WORK
 G20-2
 36" X 18"



ONLY
 R3-5R
 30" X 36"
 4" WHITE

REMOVE CONFLICTING PAVEMENT MARKINGS

4" WHITE SKIP DASH (2' DASH - 6' SKIP)

ONLY
 R3-5R
 30" X 36"

REMOVE CONFLICTING PAVEMENT MARKINGS

4" WHITE SKIP DASH (2' DASH - 6' SKIP)

REMOVE CONFLICTING PAVEMENT MARKINGS

LETTERS & SYMBOLS, WHITE

REMOVE CONFLICTING PAVEMENT MARKINGS

W2-I115(0) 36" x 18"

WORK ZONE SPEED LIMIT 40 BEGINS
 \$375 FINE MINIMUM

R2-1 36" x 48"

W2-I113(0) 36" x 12"

W2-I106 36" x 18"

SPEED ZONE AHEAD

ROAD CONSTRUCTION AHEAD

END WORK ZONE SPEED LIMIT
 G20-I103(0)
 60" X 36"

ROAD CONSTRUCTION AHEAD
 W20-1

SPEED ZONE AHEAD
 W3-5

WORK ZONE SPEED LIMIT 40 BEGINS
 \$375 FINE MINIMUM
 W2-I115(0) 36" x 18"
 R2-1 36" x 48"
 W2-I113(0) 36" x 12"
 W2-I106 36" x 18"

4" WHITE

24" WHITE

REMOVE CONFLICTING PAVEMENT MARKINGS

1475+00

1480+00

1485+00

RANDALL ROAD

SHOULDER CLOSED AHEAD
 W21-5B(R)

NO ACCESS TO JEWEL FROM E.B. MCDONALD RD. USE GYORR RD ENTRANCE AHEAD
 CUSTOM VAR X VAR

SEE SHEET NO. 47 STEARNS ROAD MOT

REMOVE CONFLICTING PAVEMENT MARKINGS

END WORK ZONE SPEED LIMIT
 G20-I103(0)
 60" X 36"

FILE NAME = 	USER NAME = jsm	DESIGNED - JSM	REVISED -	KANE COUNTY DIVISION OF TRANSPORTATION	MAINTENANCE OF TRAFFIC - MCDONALD ROAD & RANDALL ROAD STAGE 4A			F.A. RTE. 361	SECTION 06-00214-25-BR	COUNTY KANE	TOTAL SHEETS 220	SHEET NO. 46				
	PLOT SCALE = 50.0000' / IN.	CHECKED - DNM	REVISED -					SCALE: 1" = 50' SHEET NO. 10 OF 14 SHEETS STA. TO STA. 436+00				FED. ROAD DIST. NO. 1 ILLINOIS FED. AID PROJECT				
	PLOT DATE = 3/30/2009	DATE = 3/30/09	REVISED -													
	CONTRACT NO. 63076															



LIMITS OF WORK ZONE FOR THIS STAGE

LEGEND

- ○ ○ TYPE I OR II BARRICADES (OR DRUMS) WITH MONO-DIRECTIONAL STEADY-BURN LIGHTS @ 50' CTRS (25' SPACING IN TAPERS, 10' SPACING IN CORNER RADII)
- TT TT TYPE III BARRICADE WITH FLASHING LIGHTS
- ↑ TEMPORARY TRAFFIC SIGN ON PERMANENT SUPPORT
- DIRECTION OF TRAFFIC
- FLASHING AMBER BEACON

NOTE:

ALL DIAMOND SHAPE CONSTRUCTION WARNING SIGNS SHALL BE 48" X 48" UNLESS OTHERWISE NOTED

TYPE I OR TYPE II BARRICADES ARE NOT PERMITTED ON RANDALL ROAD OR STEARNS ROAD FROM STA. 434+00 TO STA. 437+00, CONTRACTOR SHALL USE DRUMS ONLY

SEE IDOT STANDARD DETAIL 701701-05

END ROAD WORK
G20-2
36" X 18"



ONLY
R3-5R
30" X 36"
4" WHITE

ONLY
R3-5R
30" X 36"

REMOVE CONFLICTING PAVEMENT MARKINGS

REMOVE CONFLICTING PAVEMENT MARKINGS

REMOVE CONFLICTING PAVEMENT MARKINGS

W2-I115(O) 36" x 18"
R2-1 36" x 48"
W2-I113(O) 36" x 12"
W2-I106 36" x 18"

WORK ZONE
SPEED LIMIT
40
BEGINS
\$375 FINE
MINIMUM

SPEED ZONE AHEAD

ROAD CONSTRUCTION AHEAD

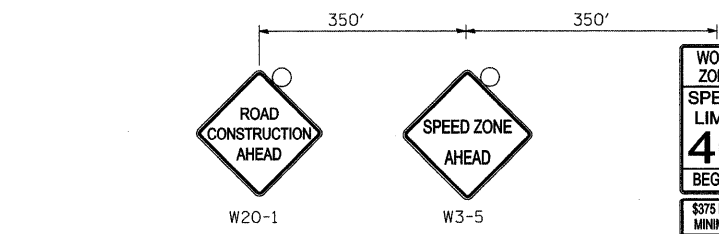

END WORK ZONE SPEED LIMIT
G20-I103(O)
60" X 36"

SHOULDER CLOSED AHEAD
W21-5B(R)

NO ACCESS TO JEWEL FROM E.B. MCDONALD RD. USE GYORR RD. ENTRANCE AHEAD
CUSTOM VAR X VAR

SEE SHEET NO. 49 STEARNS ROAD MOT

END WORK ZONE SPEED LIMIT
G20-I103(O)
60" X 36"

	FILE NAME =	DESIGNED - JSM	REVISED -	KANE COUNTY DIVISION OF TRANSPORTATION	MAINTENANCE OF TRAFFIC - MCDONALD ROAD & RANDALL ROAD STAGE 4B	F.A. RTE.	SECTION	COUNTY	TOTAL SHEETS	SHEET NO.
	USER NAME = jsm	DRAWN - JSM	REVISED -			361	06-00214-25-BR	KANE	220	48
	PLOT SCALE = 50.00000' / IN.	CHECKED - DNM	REVISED -			CONTRACT NO. 63076				
PLOT DATE = 3/30/2009	DATE - 3/30/09	REVISED -	SCALE: 1" = 50'	SHEET NO. 11 OF 14 SHEETS	STA. TO STA. 436+00	FED. ROAD DIST. NO. 1 ILLINOIS FED. AID PROJECT				

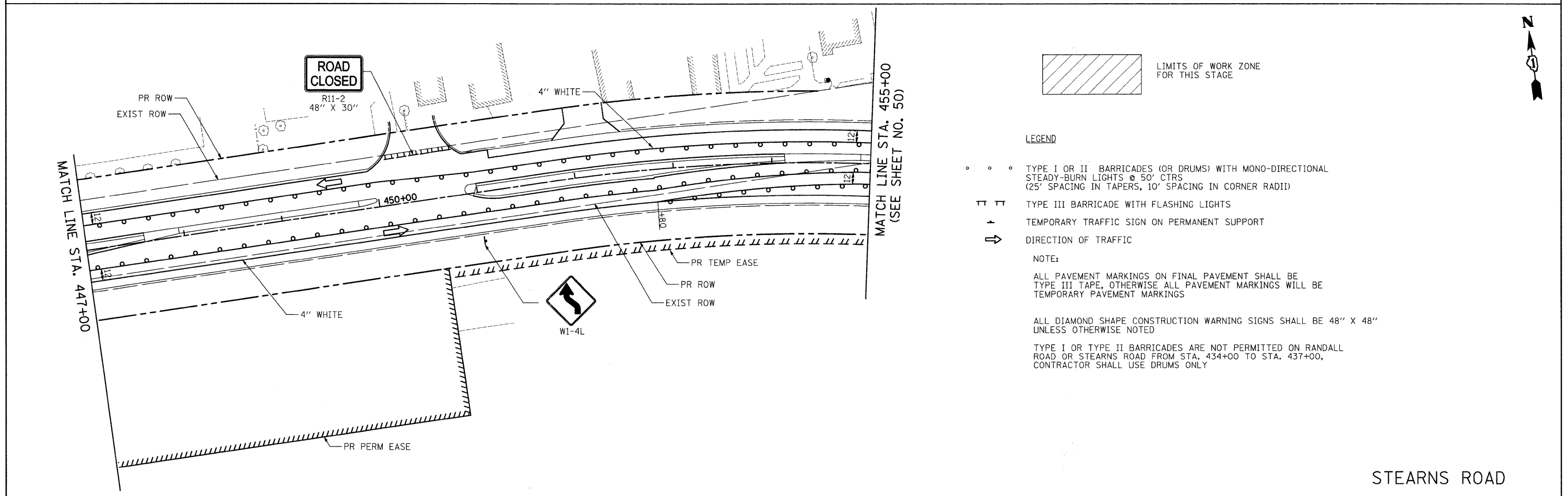
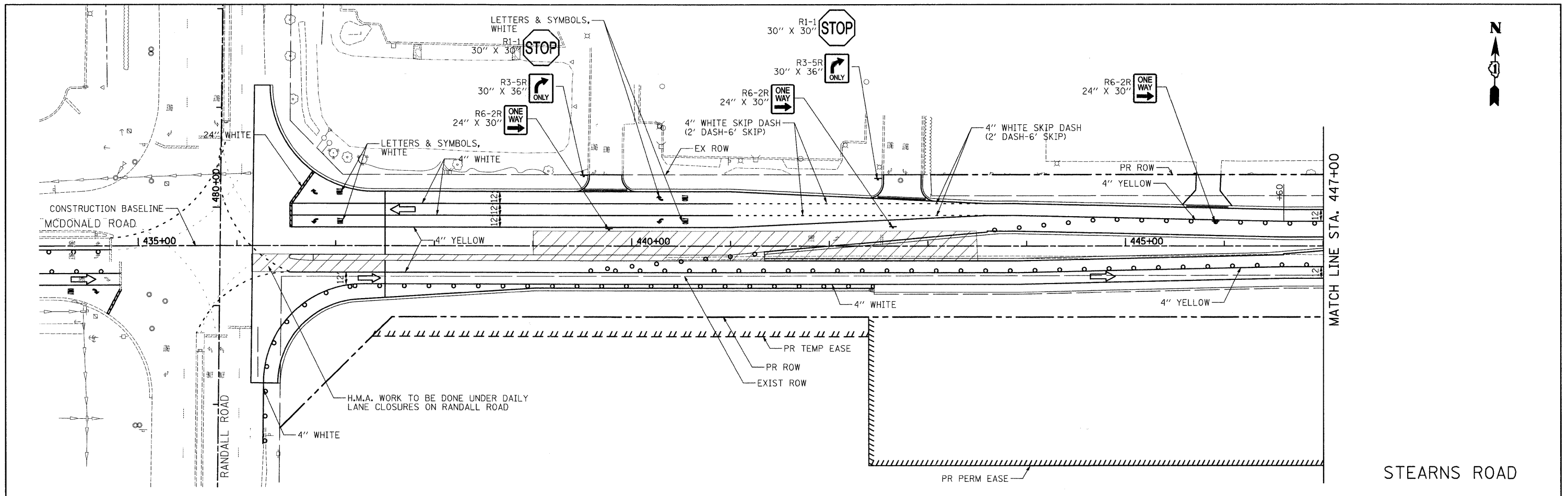

LEGEND

- ○ ○ TYPE I OR II BARRICADES (OR DRUMS) WITH MONO-DIRECTIONAL STEADY-BURN LIGHTS @ 50' CTRS (25' SPACING IN TAPERS, 10' SPACING IN CORNER RADII)
- T T TYPE III BARRICADE WITH FLASHING LIGHTS
- ↑ ↓ TEMPORARY TRAFFIC SIGN ON PERMANENT SUPPORT
- ⇨ ⇩ DIRECTION OF TRAFFIC

NOTE:

ALL PAVEMENT MARKINGS ON FINAL PAVEMENT SHALL BE TYPE III TAPE, OTHERWISE ALL PAVEMENT MARKINGS WILL BE TEMPORARY PAVEMENT MARKINGS

ALL DIAMOND SHAPE CONSTRUCTION WARNING SIGNS SHALL BE 48" X 48" UNLESS OTHERWISE NOTED

TYPE I OR TYPE II BARRICADES ARE NOT PERMITTED ON RANDALL ROAD OR STEARNS ROAD FROM STA. 434+00 TO STA. 437+00, CONTRACTOR SHALL USE DRUMS ONLY

FILE NAME =	USER NAME = jsm	DESIGNED - JSM	REVISED -	KANE COUNTY DIVISION OF TRANSPORTATION	MAINTENANCE OF TRAFFIC - STEARNS ROAD STAGE 4B	F.A. RTE. 361	SECTION 06-00214-25-BR	COUNTY KANE	TOTAL SHEETS 220	SHEET NO. 49		
PLOT SCALE = 50.0000' / IN.	CHECKED - DNM	REVISOR -	REVISOR -			SCALE: 1" = 50'	SHEET NO. 13 OF 14 SHEETS	STA. 436+00	TO STA. 455+00	CONTRACT NO. 63076		
PLOT DATE = 3/30/2009	DATE - 3/30/09	REVISOR -	REVISOR -			FED. ROAD DIST. NO. 1 ILLINOIS FED. AID PROJECT						



LIMITS OF WORK ZONE FOR THIS STAGE

LEGEND

- ○ ○ TYPE I OR II BARRICADES (OR DRUMS) WITH MONO-DIRECTIONAL STEADY-BURN LIGHTS @ 50' CTRS (25' SPACING IN TAPERS, 10' SPACING IN CORNER RADII)
- TTT TYPE III BARRICADE WITH FLASHING LIGHTS
- ↑ TEMPORARY TRAFFIC SIGN ON PERMANENT SUPPORT
- DIRECTION OF TRAFFIC
- FLASHING AMBER BEACON

NOTE:

ALL PAVEMENT MARKINGS ON FINAL PAVEMENT SHALL BE TYPE III TAPE, OTHERWISE ALL PAVEMENT MARKINGS WILL BE TEMPORARY PAVEMENT MARKINGS

ALL DIAMOND SHAPE CONSTRUCTION WARNING SIGNS SHALL BE 48" X 48" UNLESS OTHERWISE NOTED

EXISTING W11-10 (TRUCK CROSSING) SIGNS SHALL REMAIN IN PLACE TO WARN MOTORISTS ABOUT TRUCKS ENTERING AND LEAVING HIGHWAY, IF THE EXISTING SIGNS ARE REMOVED FOR ANY REASON, TEMPORARY BARRICADE MOUNTED W11-10 SHALL BE INSTALLED IN PLACE.

MATCH LINE STA. 455+00
(SEE SHEET NO. 48 & 49)

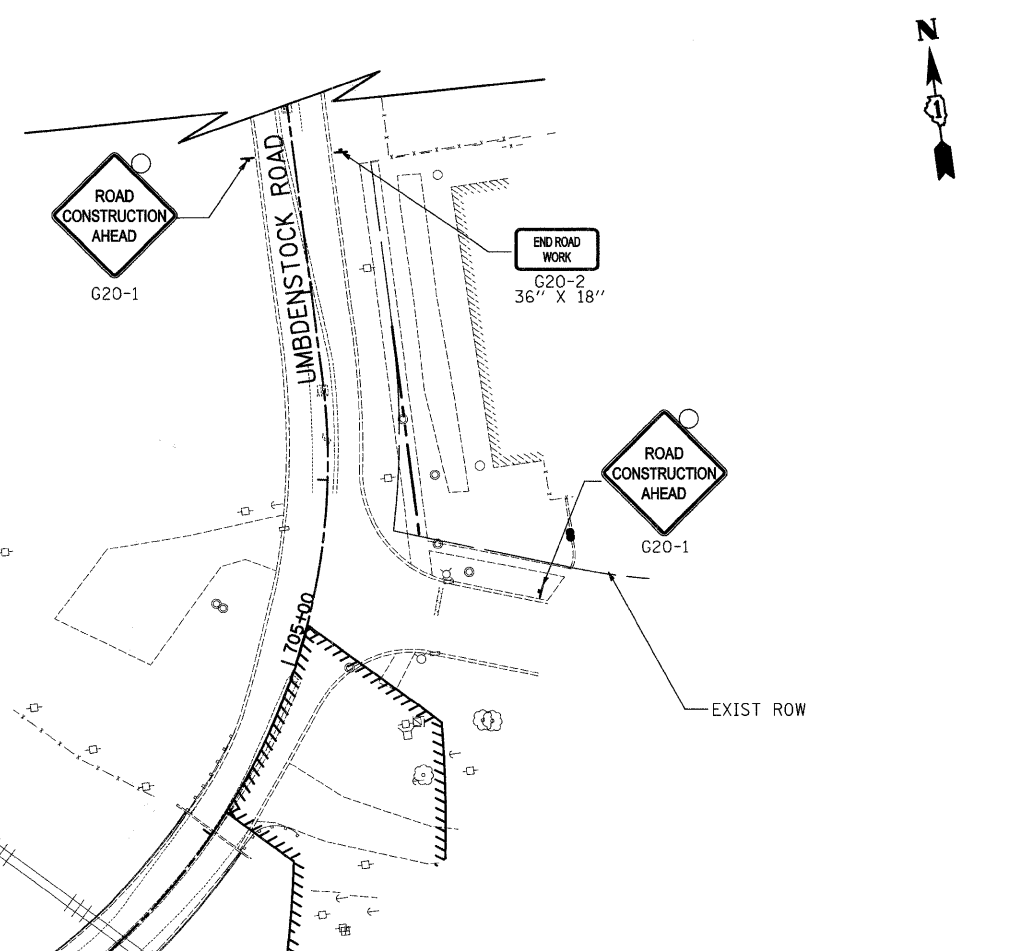
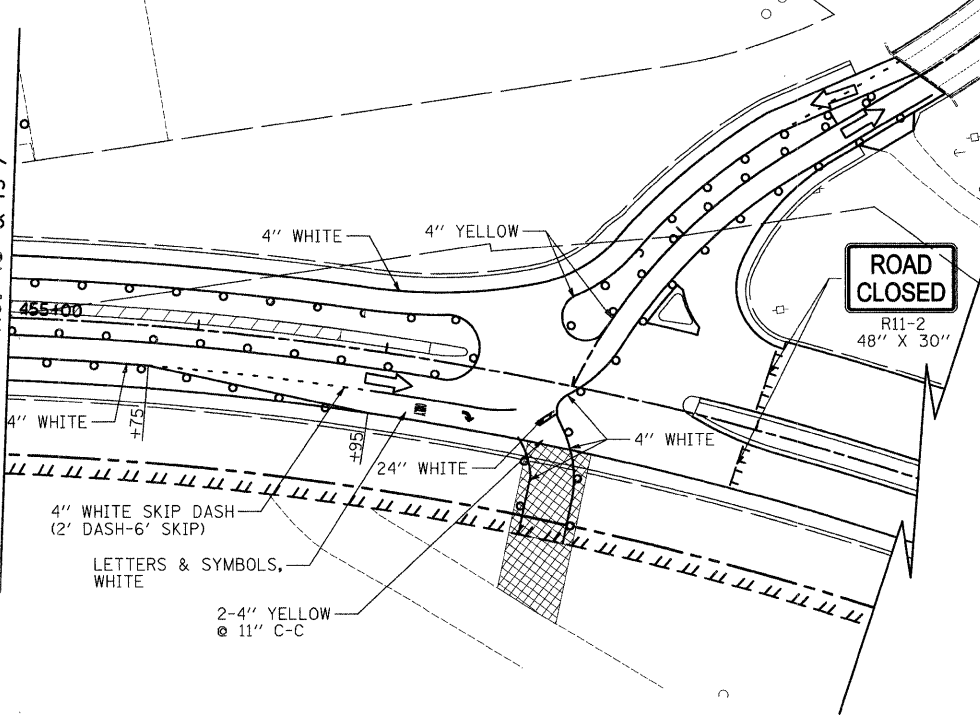

STEARNS ROAD



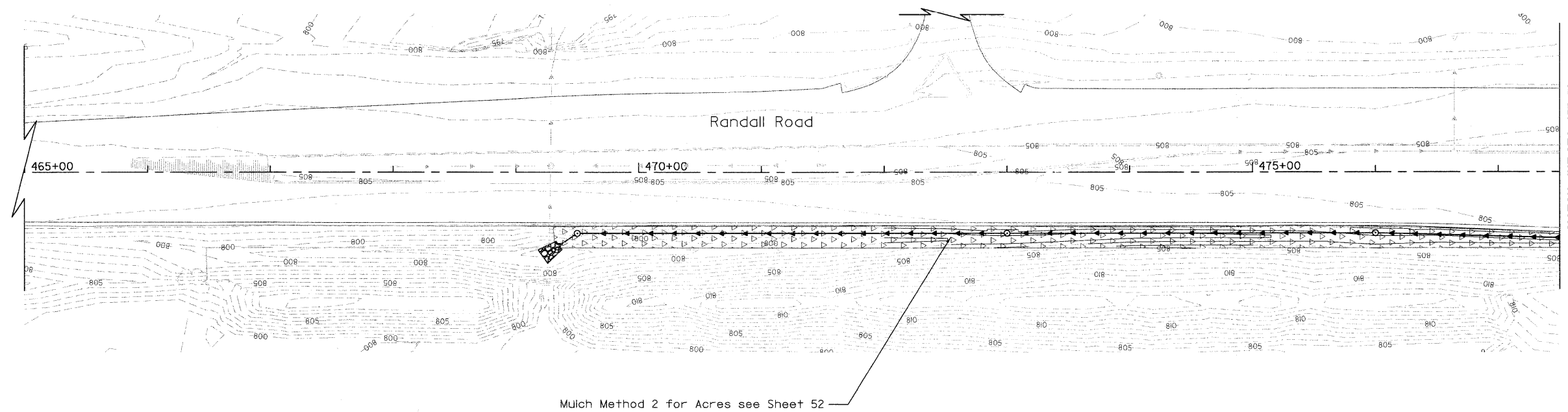
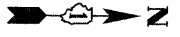



FILE NAME = 	USER NAME = jsm DESIGNED - JSM DRAWN - JSM PLOT SCALE = 50.0000' / IN. PLOT DATE = 3/30/2009	REVISIONS: REVISION 1 - REVISION 2 - REVISION 3 - REVISION 4 -	KANE COUNTY DIVISION OF TRANSPORTATION	MAINTENANCE OF TRAFFIC - STEARNS ROAD STAGE 4A & 4B	F.A. RTE. 361 SECTION 06-00214-25-BR COUNTY KANE TOTAL SHEETS 220 SHEET NO. 50 CONTRACT NO. 63076
	SCALE: 1" = 50' SHEET NO. 14 OF 14 SHEETS STA. 455+00 TO STA.	FED. ROAD DIST. NO. 1 ILLINOIS FED. AID PROJECT			



MATCH LINE STA. 477+50
SEE SHEET NO. 52

Mulch Method 2 for Acres see Sheet 52

LEGEND:

-  Mulch, Method 2/Seeding, Class 7
-  Inlet Filters
-  Inlet & Pipe Protection
-  Culvert Inlet Protection-Stone
-  FES Outlet Protection
-  Rock Check Dam
-  Sediment Control, Silt Fence

NOTES

FOR RIPRAP QUANTITIES, SEE SCHEDULE OF QUANTITIES SHEET 14

Hey and Associates, Inc. Water Resources, Wetlands and Ecology	USER NAME =	DESIGNED - TRP/JDK	REVISED -	KANE COUNTY DIVISION OF TRANSPORTATION	LANDSCAPE RESTORATION & EROSION CONTROL PLAN STAGE 5	F.A.R.T.E.:	SECTION	COUNTY	TOTAL SHEETS	SHEET NO.			
							36I	06-00214-25-BR	KANE	220	51		
	PLOT SCALE =	CHECKED - TLP	REVISED -				SCALE: 1" = 50'	SHEET NO. 1 OF 9 SHEETS	STA. 465+00 TO STA. 477.50	CONTRACT NO. 63076			
	PLOT DATE =	DATE - 03/30/09	REVISED -				FED. ROAD DIST. NO. 1 ILLINOIS FED. AID PROJECT						

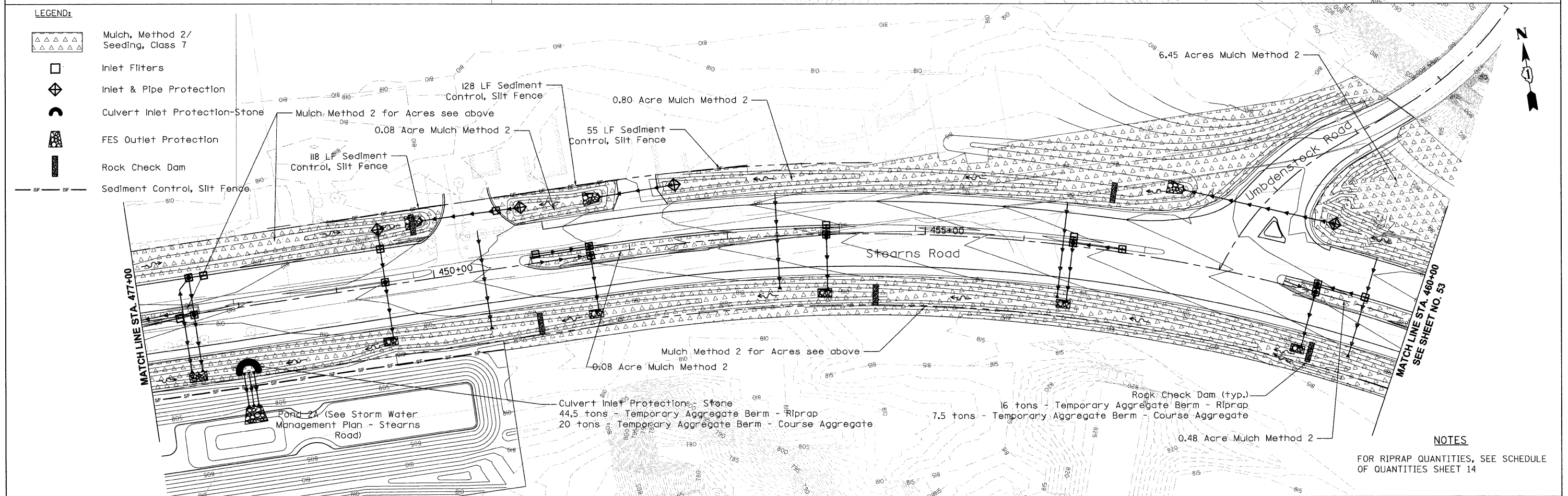
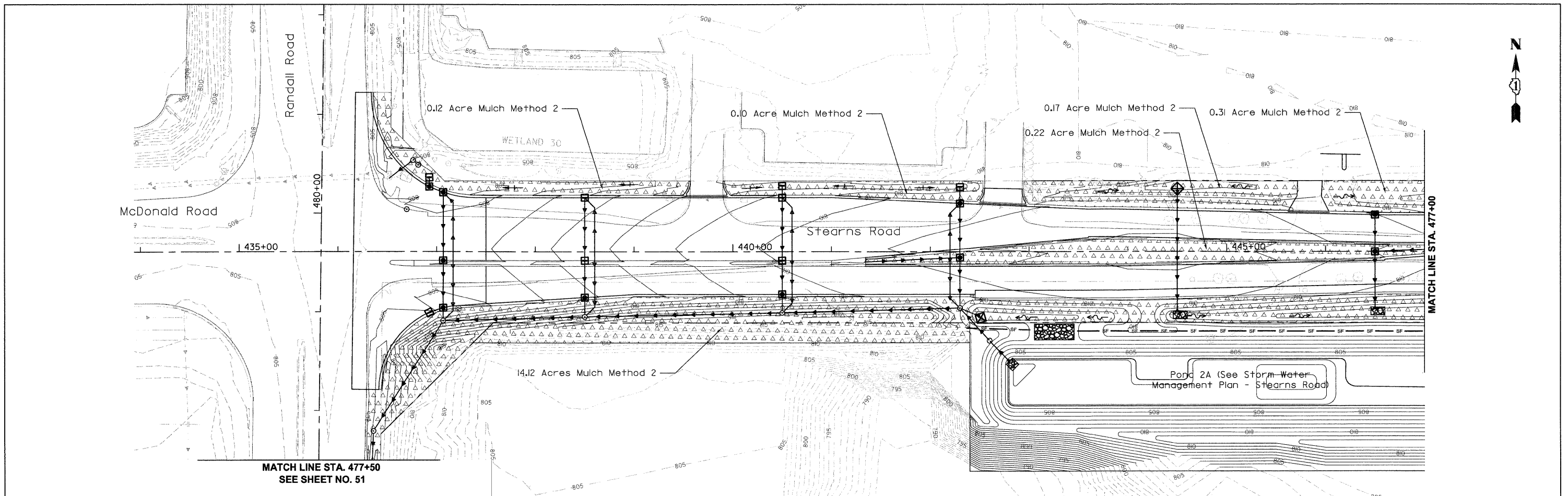

- LEGEND:**
- Mulch, Method 2/
Seeding, Class 7
 - Inlet Filters
 - Inlet & Pipe Protection
 - Culvert Inlet Protection - Stone
 - FES Outlet Protection
 - Rock Check Dam
 - Sediment Control, Silt Fence

NOTES
FOR RIPRAP QUANTITIES, SEE SCHEDULE OF QUANTITIES SHEET 14

Hey and Associates, Inc. Water Resources, Wetlands and Ecology	USER NAME =	DESIGNED — TRP/JDK	REVISED —	KANE COUNTY DIVISION OF TRANSPORTATION	LANDSCAPE RESTORATION & EROSION CONTROL PLAN	F.A. RTE.	SECTION	COUNTY	TOTAL SHEETS	SHEET NO.
	PLOT SCALE =	DRAWN — CFR	REVISED —			361	06-00214-25-BR	KANE	220	52
PLOT DATE =	CHECKED — TLP	REVISED —		SCALE: 1" = 50' SHEET NO. 2 OF 9 SHEETS STA. 436+15.8 TO STA. 460+00 STAGE 5		FED. ROAD DIST. NO. 1 ILLINOIS FED. AID PROJECT CONTRACT NO. 63076				
	DATE — 03/30/09	REVISED —								

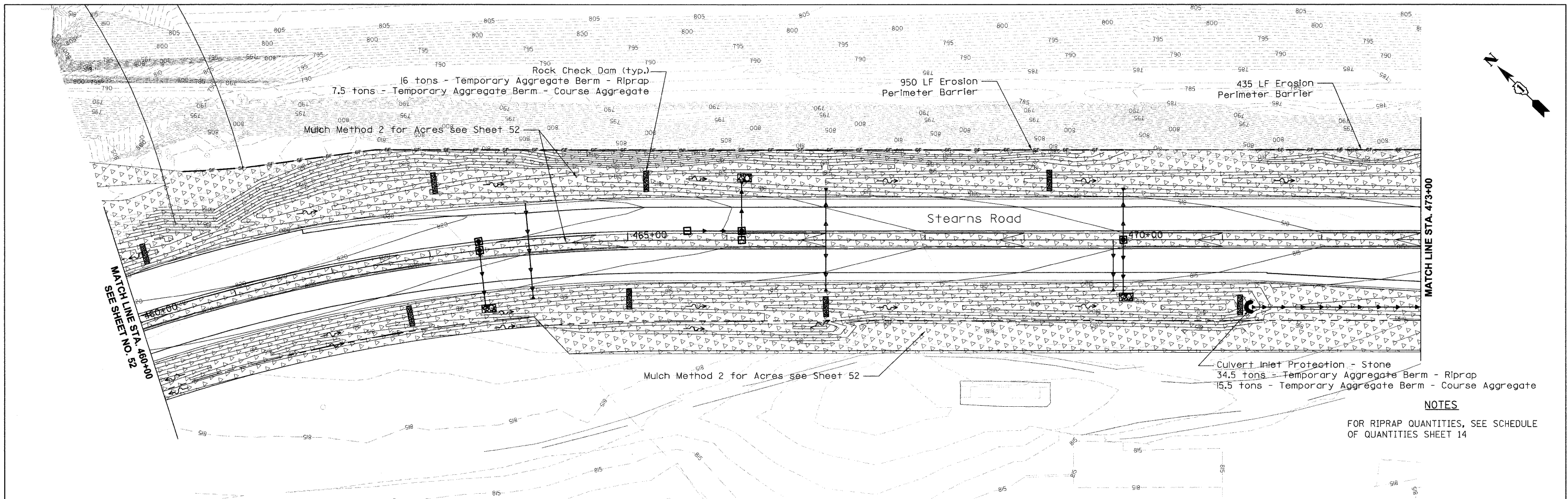

NOTES
FOR RIPRAP QUANTITIES, SEE SCHEDULE OF QUANTITIES SHEET 14

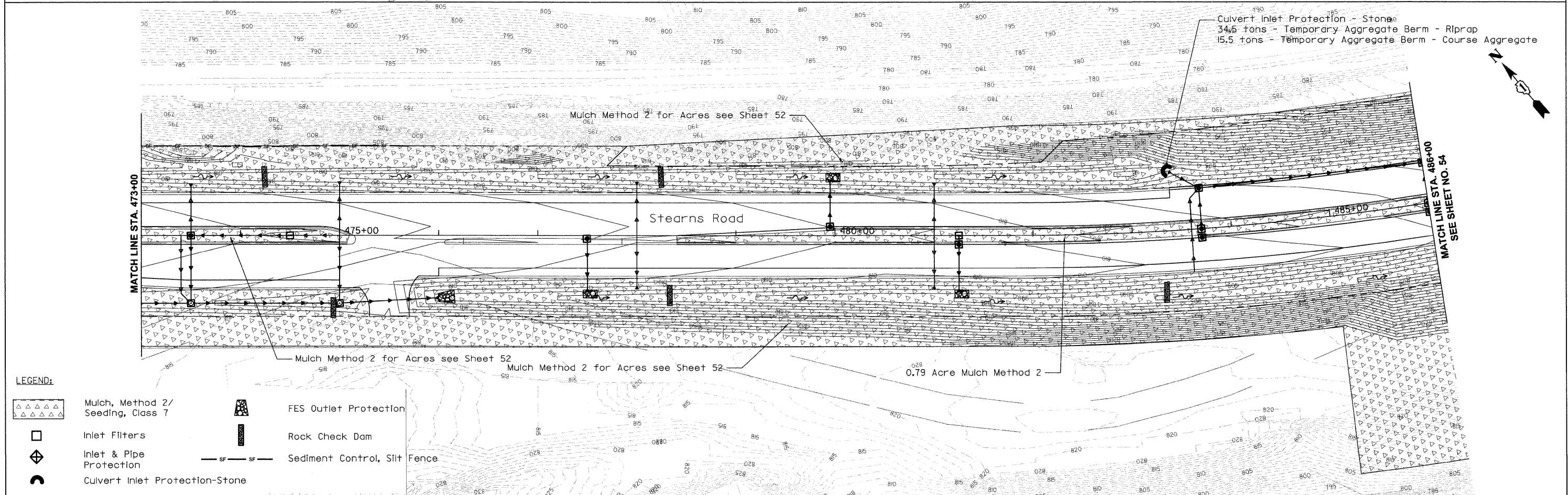

LEGEND:

	Mulch, Method 2/ Seeding, Class 7		FES Outlet Protection
	Inlet Filters		Rock Check Dam
	Inlet & Pipe Protection		Sediment Control, Silt Fence
	Culvert Inlet Protection-Stone		

Hey and Associates, Inc. Water Resources, Wetlands and Ecology	USER NAME =	DESIGNED — TRP/JDK	REVISED —	KANE COUNTY DIVISION OF TRANSPORTATION	LANDSCAPE RESTORATION & EROSION CONTROL PLAN	F.A. —	SECTION	COUNTY	TOTAL SHEETS	SHEET NO.
	PLOT SCALE =	DRAWN — CFR	REVISED —			361	06-00214-25-BR	KANE	220	53
	PLOT DATE =	CHECKED — TLP	REVISED —			STAGE 5		CONTRACT NO. 63076		
			DATE — 03/30/09	REVISED —	SCALE: 1" = 50'	SHEET NO. 3 OF 9 SHEETS STA. 460+00 TO STA. 486+00		FED. ROAD DIST. NO. 1 ILLINOIS FED. AID PROJECT		

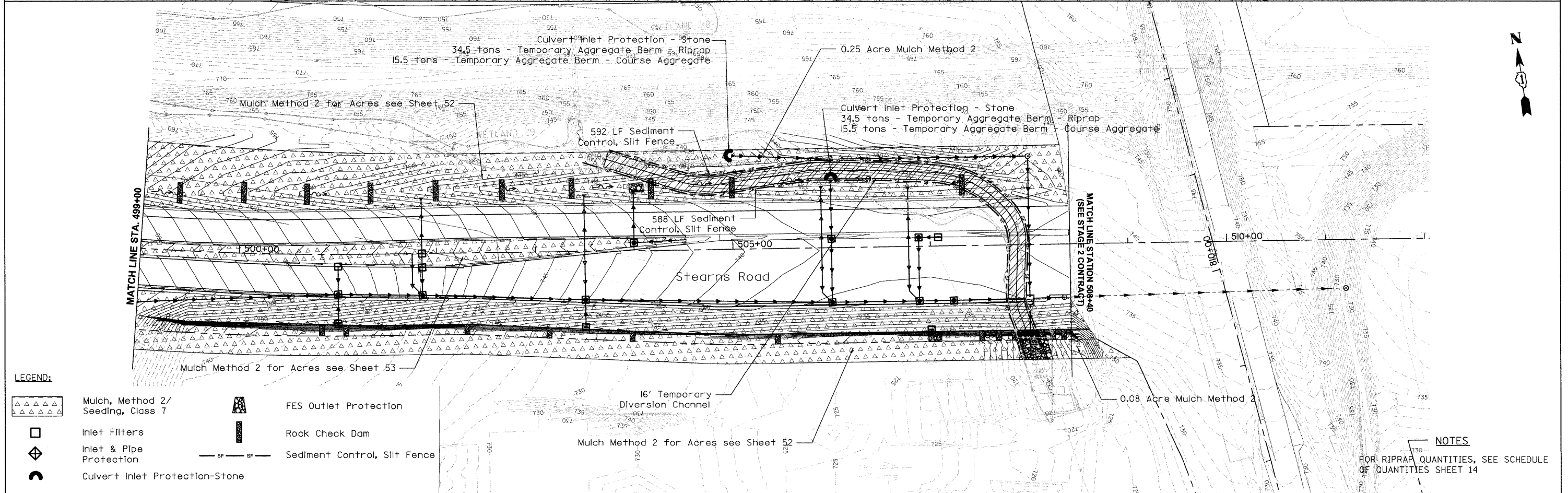
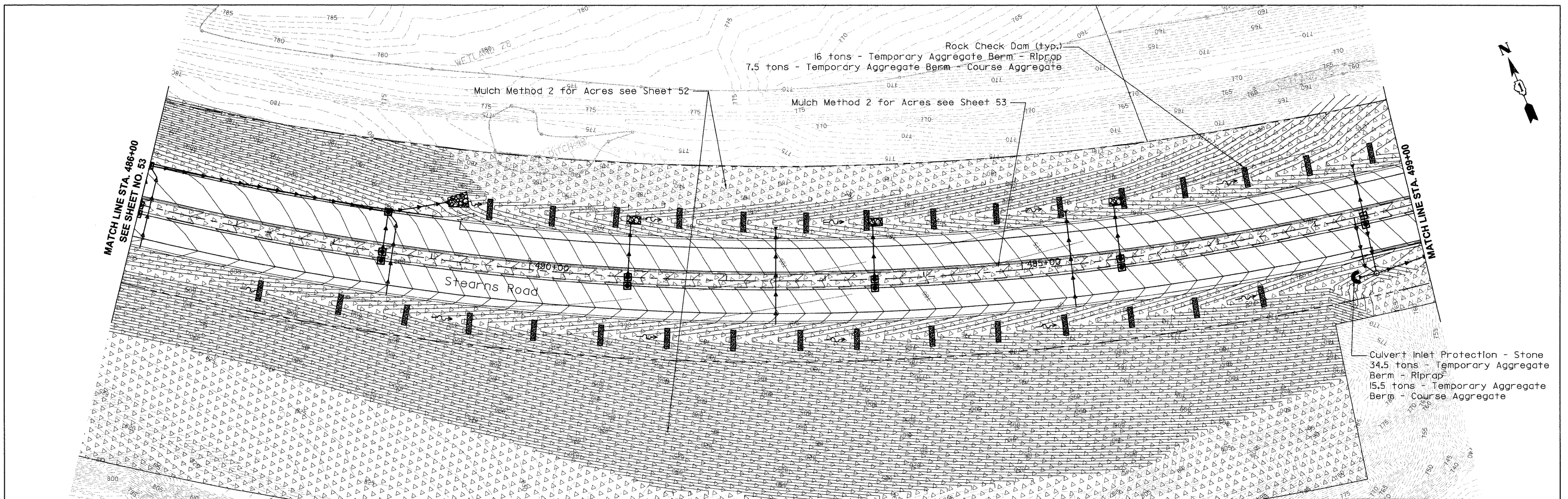

LEGEND:

	Mulch, Method 2/ Seeding, Class 7		FES Outlet Protection
	Inlet Filters		Rock Check Dam
	Inlet & Pipe Protection		Sediment Control, Silt Fence
	Culvert Inlet Protection-Stone		

NOTES
FOR RIPRAP QUANTITIES, SEE SCHEDULE OF QUANTITIES SHEET 14

Hey and Associates, Inc. Water Resources, Wetlands and Ecology	USER NAME =	DESIGNED = TRP/JDK	REVISED =	KANE COUNTY DIVISION OF TRANSPORTATION	LANDSCAPE RESTORATION & EROSION CONTROL PLAN		F.A.R.T.E. = 361	SECTION = 06-00214-25-BR	COUNTY = KANE	TOTAL SHEETS = 220	SHEET NO. = 54
	PLOT SCALE =	CHECKED = TLP	REVISED =				SCALE: 1" = 50' SHEET NO. 4 OF 9 SHEETS STA. 486+00 TO STA. 508+40		STAGE 5		CONTRACT NO. 63076
	PLOT DATE =	DATE = 03/30/09	REVISED =	FED. ROAD DIST. NO. 1 ILLINOIS FED. AID PROJECT							

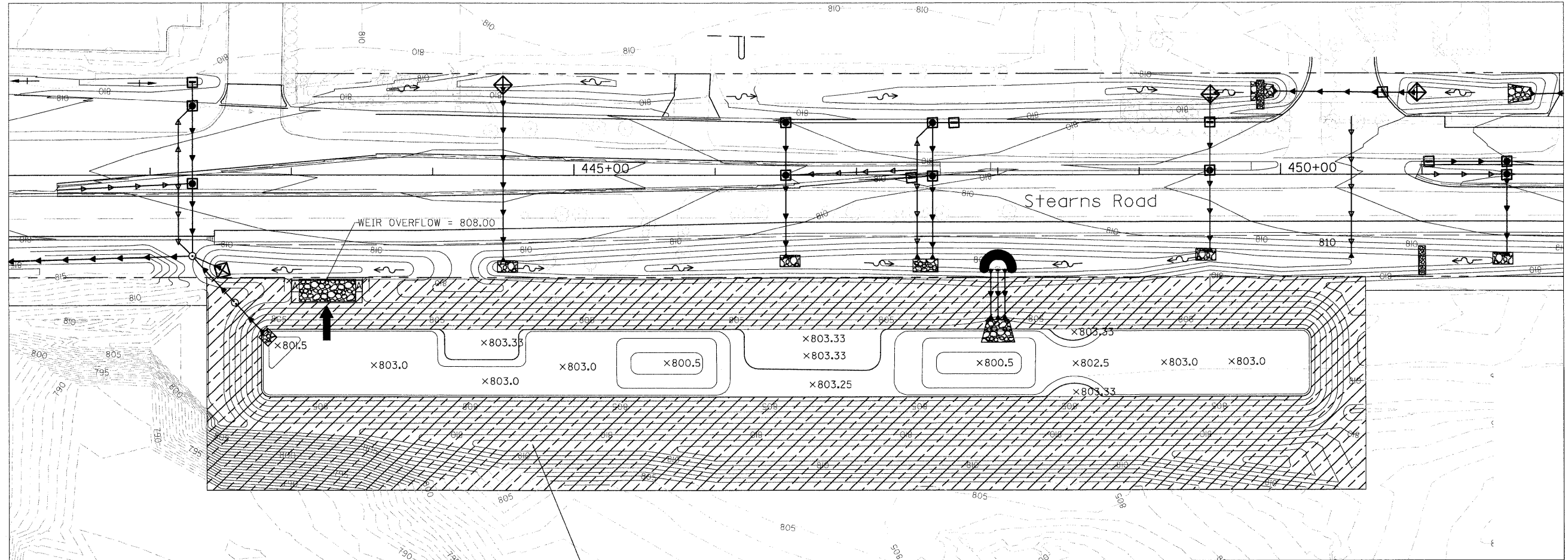

2.03 acres Seeding, Class 4 (Modified) Mesic Prairie
 2.03 acres Seeding, Class 5 (Modified) Mesic Prairie

LEGEND:

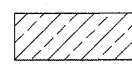
 Seeding, Class 4 (Modified) Mesic Prairie and Seeding, Class 5 (Modified) Mesic Prairie

Note: All Disturbed Areas not receiving Seeding, Class 4 (Modified) Mesic Prairie and Seeding, Class 5 (Modified) Mesic Prairie to receive Seeding, Class 7.

Hey and Associates, Inc. Water Resources, Wetlands and Ecology	USER NAME =	DESIGNED - TRP	REVISED -	KANE COUNTY DIVISION OF TRANSPORTATION	STORM WATER MANAGEMENT - STEARNS ROAD TEMPORARY SEEDING PLAN		F.A. RTE. =	SECTION	COUNTY	TOTAL SHEETS	SHEET NO.
	PLOT SCALE =	DRAWN - CFR	REVISED -				361	06-00214-25-BR	KANE	220	56
	PLOT DATE =	CHECKED - TLP	REVISED -				CONTRACT NO. 63076				
	DATE - 03/30/09	REVISED -		SCALE: 1" = 40' SHEET NO. 5 OF 9 SHEETS STA. 441+00 TO STA. 452+00		STAGE 5		FED. ROAD DIST. NO. 1 ILLINOIS FED. AID PROJECT			

EROSION CONTROL BLANKET PLAN

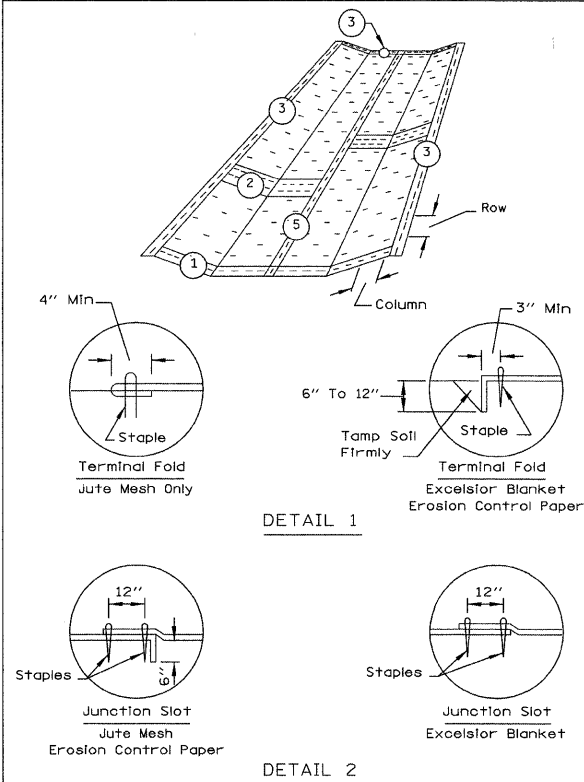

REFERENCE Project NEW STEARNS ROAD		STANDARD DWG. NO. IL-530
Designed _____ Date _____		SEET 1 OF 2
Checked _____ Date _____		DATE 5-24-94
Approved _____ Date _____		

PERIMETER EROSION BARRIER PLAN

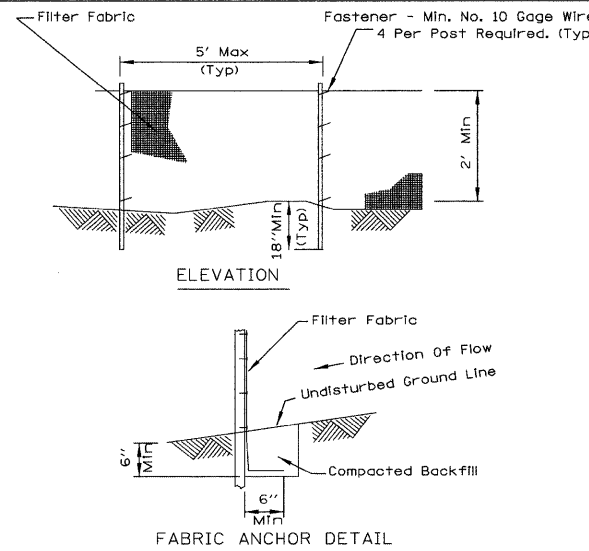

NOTES:
 1. Temporary sediment fence shall be installed prior to any grading work in the area to be protected. They shall be maintained throughout the construction period and removed in conjunction with the final grading and site stabilization.
 2. Filter fabric shall meet the requirements of material specification Article 1080.02
 3. Fence posts shall be either standard steel post or wood post with a minimum cross-sectional area of 3.0 sq. in.

REFERENCE Project NEW STEARNS ROAD		STANDARD DWG. NO. IL-620
Designed _____ Date _____		SHEET 1 OF 2
Checked _____ Date _____		DATE 11-20-01
Approved _____ Date _____		

STABILIZED CONSTRUCTION ENTRANCE PLAN

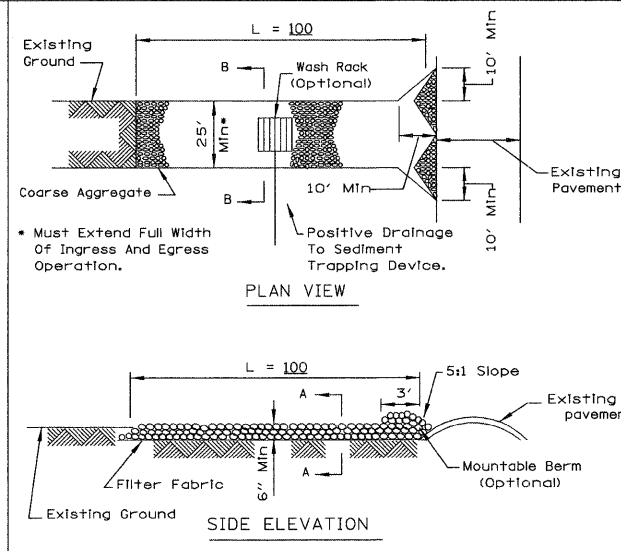

NOTES:
 1. Filter fabric shall meet the requirements of material specification Article 1080.03
 2. Rock or reclaimed concrete shall meet one of the following IDOT coarse aggregate gradation, CA-1, CA-2, CA-3 or CA-4 and be placed according to Article 281.4
 3. Any drainage facilities required because of washing shall be constructed according to manufacturers specifications.
 4. If wash racks are used they shall be installed according to the manufacturer's specifications.

REFERENCE Project NEW STEARNS ROAD		STANDARD DWG. NO. IL-630
Designed _____ Date _____		SHEET 1 OF 2
Checked _____ Date _____		DATE 8-18-94
Approved _____ Date _____		

ROCK CHECK DAM - RIPRAP

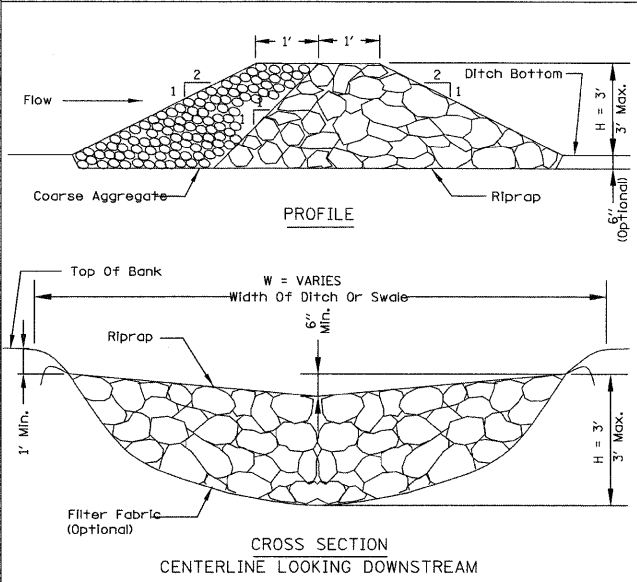

NOTES:
 1. Filter fabric shall meet the requirements of material specification Article 1080.03
 2. Coarse aggregate shall meet one of the following IDOT gradations, CA-1, CA-2, CA-3, or CA-4.
 3. Riprap shall meet IDOT gradation RR-3 or RR-4 and meet Quality Designation A. Coarse aggregate and riprap shall be placed according to construction specification Article 281.04
 4. For added stability, the base of the dam may be keyed 6 inches into the soil.
 5. See plans for spacing of dams and H dimensions.
 6. Maximum drainage area to each dam.
 ROCK CHECK DAM-COARSE AGGREGATE IL-605CA may be used for drainage areas under 2 acres.

REFERENCE Project NEW STEARNS ROAD		STANDARD DWG. NO. IL-605R
Designed _____ Date _____		SHEET 1 OF 1
Checked _____ Date _____		DATE 1-29-99
Approved _____ Date _____		

EROSION CONTROL BLANKET PLAN

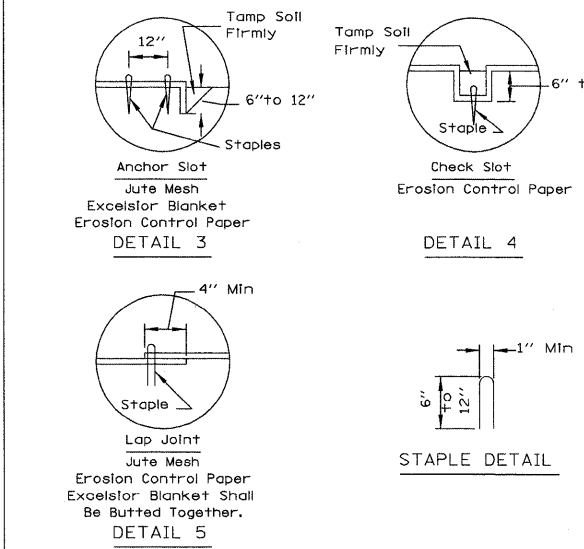

NOTES:
 1. On erosion control paper, check slots, in ditch channel shall be spaced so that one occurs within each 50' on slopes of more than 4% and less than 6%. On slopes of 6% or more, they shall be spaced so that one occurs within each 25'.
 2. Staples are to be placed alternately, in columns approximately 2' apart and in rows approximately 3' apart. Approximately 175 staples are required per 4'x 225' roll of material and 125 staples are required per 4'x 150' roll of material.
 3. Erosion control material shall be placed loosely over ground surface. Do not stretch.
 4. All terminal ends and transverse laps shall be stapled at approximately 12" intervals.

REFERENCE Project NEW STEARNS ROAD		STANDARD DWG. NO. IL-530
Designed _____ Date _____		SHEET 2 OF 2
Checked _____ Date _____		DATE 3-1-95
Approved _____ Date _____		

PERIMETER EROSION BARRIER PLAN

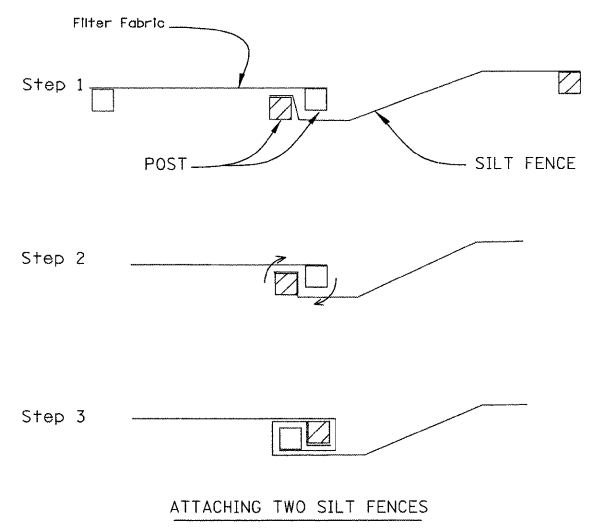

NOTES:
 1. Place the end post of the second fence inside the end post of the first fence.
 2. Rotate both posts at least 180 degrees in a clockwise direction to create a tight seal with the fabric material.
 3. Drive both posts a minimum of 18 inches into the ground and bury the flap.

REFERENCE Project NEW STEARNS ROAD		STANDARD DWG. NO. IL-620(W)
Designed _____ Date _____		SHEET 2 OF 2
Checked _____ Date _____		DATE 1-29-99
Approved _____ Date _____		

STABILIZED CONSTRUCTION ENTRANCE PLAN

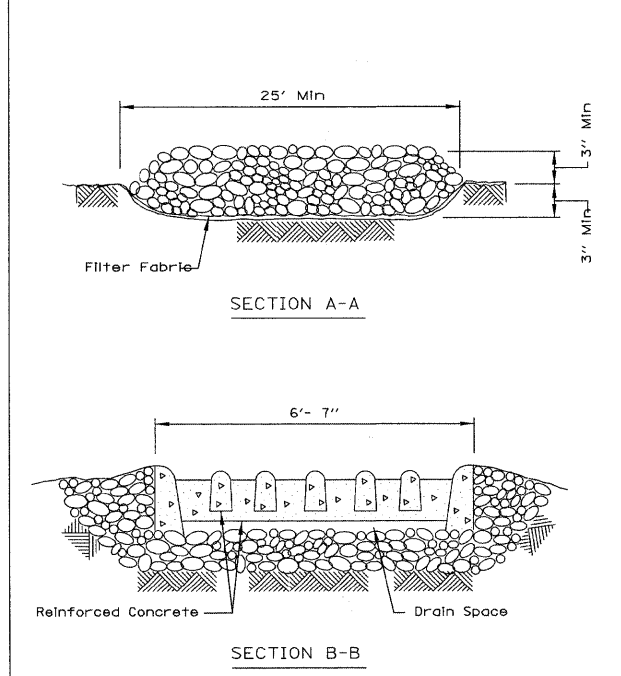

REFERENCE Project NEW STEARNS ROAD		STANDARD DWG. NO. IL-630
Designed _____ Date _____		SHEET 2 OF 2
Checked _____ Date _____		DATE 8-18-94
Approved _____ Date _____		

CULVERT INLET PROTECTION - STONE

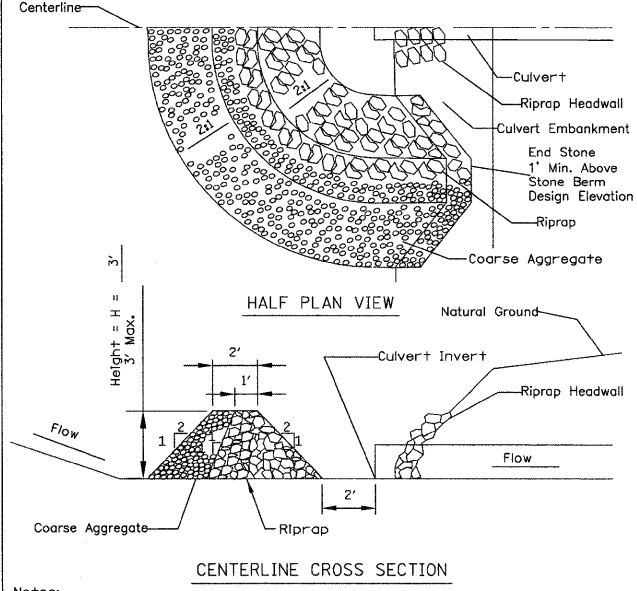

NOTES:
 1. Sediment shall be removed when the sediment has accumulated to one-half the height of the stone berm.
 2. Coarse aggregate shall meet one of the following IDOT coarse aggregate gradations, CA-1, CA-2, CA-3 or CA-4.
 3. Riprap shall meet IDOT gradation RR-3 or RR-4.
 4. Any permanent riprap, such as for the culvert headwall, shall meet IDOT Quality Designation A.
 5. Coarse aggregate and riprap shall be placed according to construction specification 25 ROCKFILL using placement Method 1 and Class III compaction.
 6. The maximum drainage area to the culvert being protected is 3 acres.
 7. See plans for H dimension. Tie the stone berm into the culvert embankment a minimum of 1 foot above the design elevation of the stone berm.

REFERENCE Project NEW STEARNS ROAD		STANDARD DWG. NO. IL-508ST
Designed _____ Date _____		SHEET 1 OF 1
Checked _____ Date _____		DATE 1-29-99
Approved _____ Date _____		

Hey and Associates, Inc. Water Resources, Wetlands and Ecology	USER NAME = XXX	DESIGNED - TRP/JDK	REVISED - XXX	KANE COUNTY DIVISION OF TRANSPORTATION	EROSION CONTROL DETAILS		STAGE 5	F.A. RTE. 361	SECTION 06-00214-25-BR	COUNTY KANE	TOTAL SHEETS 220	SHEET NO. 57	
	PLOT SCALE =	CHECKED - TLP	REVISED - XXX		SCALE: N.T.S.	SHEET NO. 7 OF 9 SHEETS		STA. TO STA.	CONTRACT NO. 63076				
	PLOT DATE =	DATE - 03/30/09	REVISED - XXX		FED. ROAD DIST. NO. 1 ILLINOIS FED. AID PROJECT								

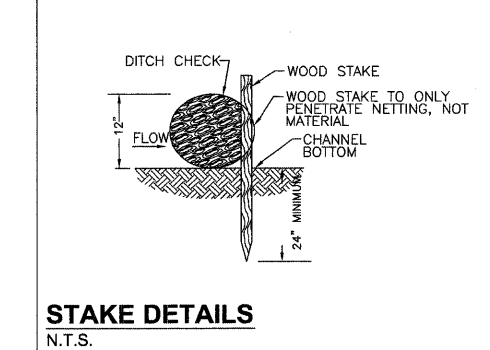
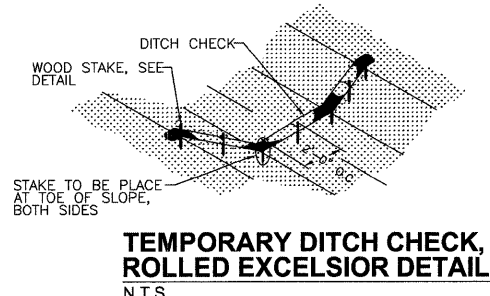

TEMPORARY DITCH CHECK, ROLLED EXCELSIOR DETAIL
N.T.S.

STAKE DETAILS
N.T.S.

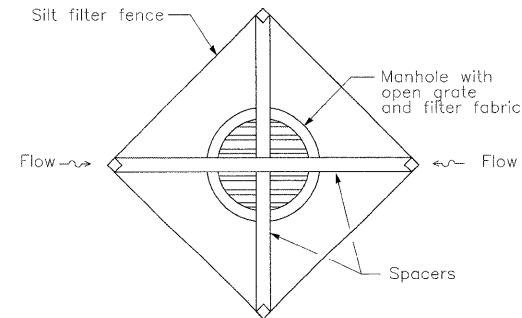
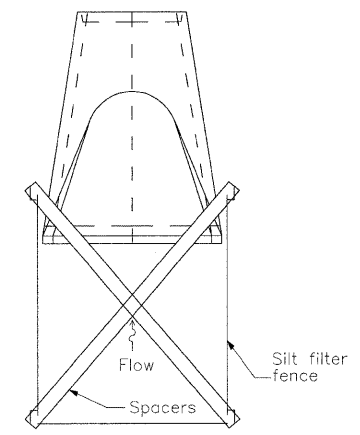

INLET AND PIPE PROTECTION DETAIL
N.T.S.

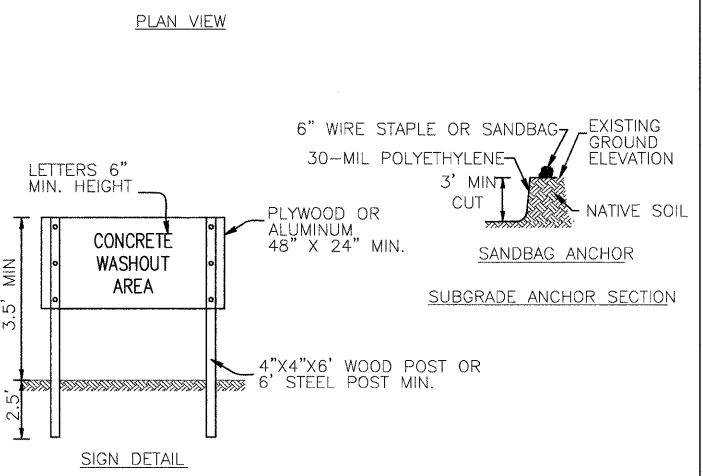
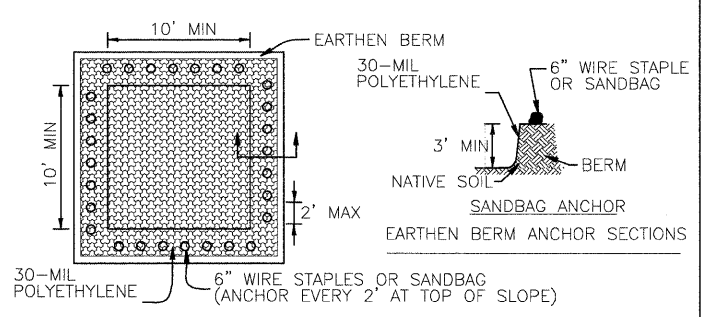

NOTES:
 MAINTAINING TEMPORARY CONCRETE WASHOUT FACILITIES SHALL INCLUDE REMOVING AND DISPOSING OF HARDENED CONCRETE AND/OR SLURRY AND RETURNING THE FACILITIES TO A FUNCTIONAL CONDITION.
 FACILITY SHALL BE CLEANED OR RECONSTRUCTED IN A NEW AREA ONCE WASHOUT BECOMES TWO-THIRDS FULL.

TEMPORARY CONCRETE WASHOUT FACILITY - EARTHEN TYPE

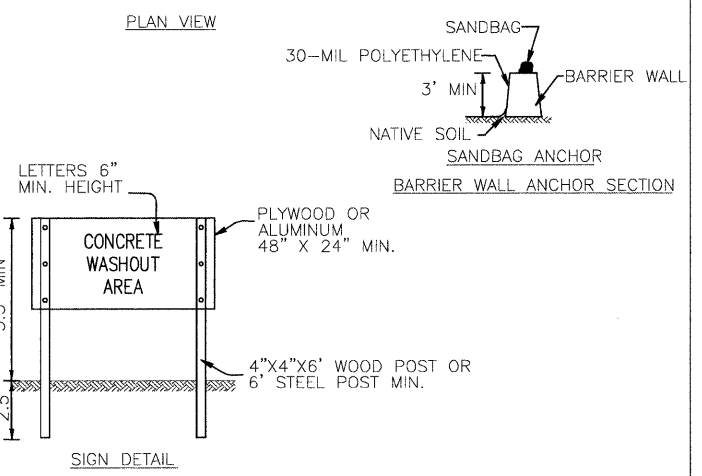
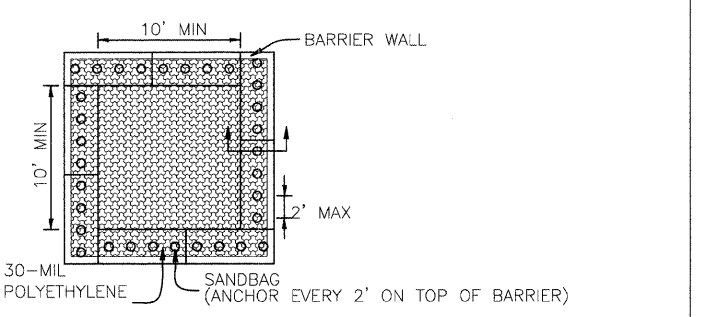

NOTES:
 MAINTAINING TEMPORARY CONCRETE WASHOUT FACILITIES SHALL INCLUDE REMOVING AND DISPOSING OF HARDENED CONCRETE AND/OR SLURRY AND RETURNING THE FACILITIES TO A FUNCTIONAL CONDITION.
 FACILITY SHALL BE CLEANED OR RECONSTRUCTED IN A NEW AREA ONCE WASHOUT BECOMES TWO-THIRDS FULL.

TEMPORARY CONCRETE WASHOUT FACILITY - BARRIER WALL

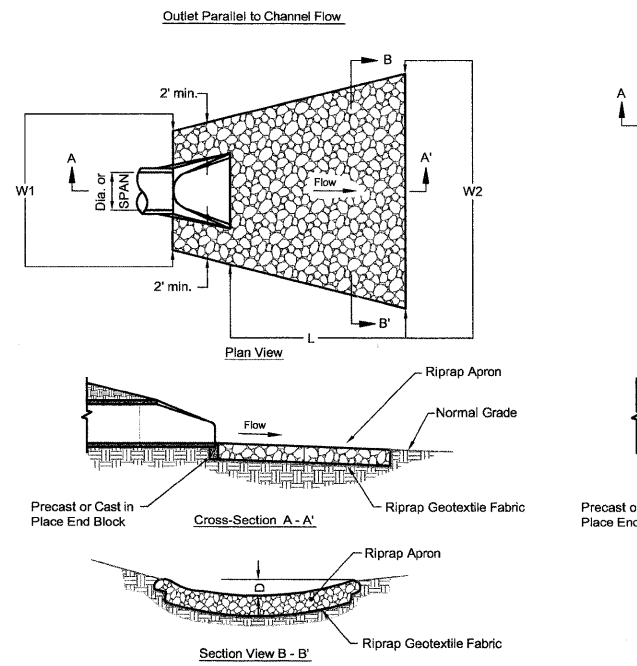

ROCK OUTLET PROTECTION DETAIL
N.T.S.

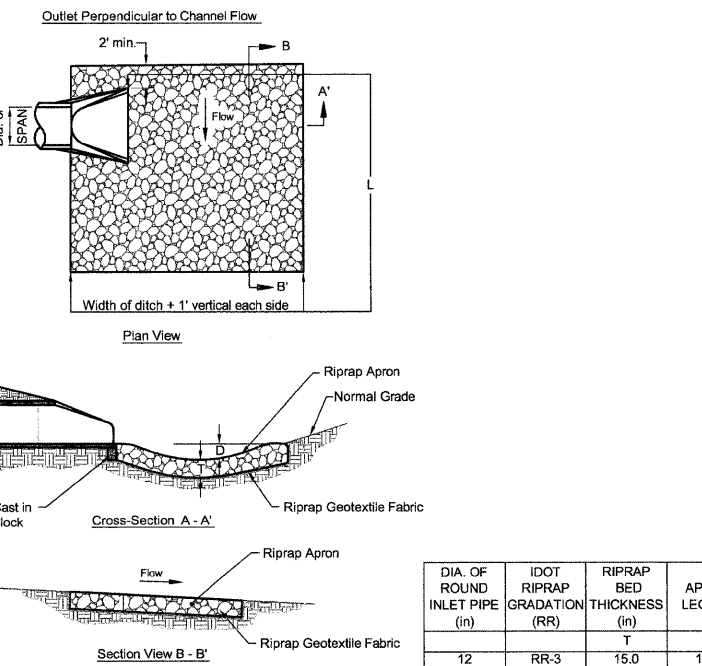

ROCK OUTLET PROTECTION DETAIL
N.T.S.

DIA. OF ROUND INLET PIPE (in)	IDOT RIPRAP GRADATION (RR)	RIPRAP BED THICKNESS (in)	APRON LENGTH (ft)	APRON WIDTH UPSTREAM (ft)	APRON WIDTH DOWNSTREAM (ft)	DEPTH BELOW NORMAL GRADE
			T	W1	W2	D
12	RR-3	15.0	12.0	5.0	11.0	6.0
15	RR-3	15.0	14.0	5.0	12.0	6.0
18	RR-3	15.0	16.0	5.5	13.5	7.0
24	RR-4	20.0	20.0	6.0	16.0	10.0
30	RR-4	20.0	22.0	6.0	17.0	11.0
36	RR-4	20.0	24.0	7.0	19.0	11.0

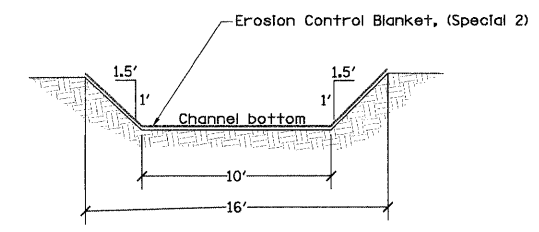

TEMPORARY DIVERSION CHANNEL
N.T.S.

SEDIMENTATION AND EROSION CONTROL NOTES

1. Unless otherwise indicated, all vegetative and structural erosion and sediment control practices will be constructed according to minimum standards and specifications in the Illinois Urban Manual revised February 2002.
2. The Kane-DuPage Soil and Water Conservation District (KDSWCD) must be notified one week prior to the pre-construction conference, one week prior to the commencement of land disturbing activities, and one week prior to the final inspection.
3. A copy of the approved erosion and sediment control plan shall be maintained on the site at all times.
4. Prior to commencing land-disturbing activities in areas other than indicated on these plans (including but not limited to, additional phases of development and off-site borrow or waste areas) a supplementary erosion control plan shall be submitted to the owner for review by the KDSWCD.
5. The contractor is responsible for installation of any additional erosion control measures necessary to prevent erosion and sedimentation as determined by the KDSWCD.
6. During dewatering operations, water will be pumped into sediment basins or silt traps. Dewatering directly into field tiles or stormwater structures is prohibited.
7. Also, please add note to state that, "it is the responsibility of the landowner and/or general contractor to inform any sub-contractor(s) who may perform work on this project, of the requirements in implementing and maintaining these erosion control plans and the National Pollutant Discharge Elimination System (NPDES) permit requirements set forth by the Illinois EPA."
8. Competed slopes (sections of road embankment) shall be seeded and mulched as the excavation proceeds to the extent considered desirable and practical. Under no circumstances shall final grading and shaping be prolonged so that the entire project can be seeded at one time.
9. Silt fence is to be installed following the completion and stabilization of the stormwater facilities and is to remain in place until the contributing area (or upland embankment) is stabilized.
10. Priority shall be given to the completion and stabilization of detention areas. Once the contributing area is stabilized the basin may need to be cleaned out, restored and the final proposed grade must be achieved.

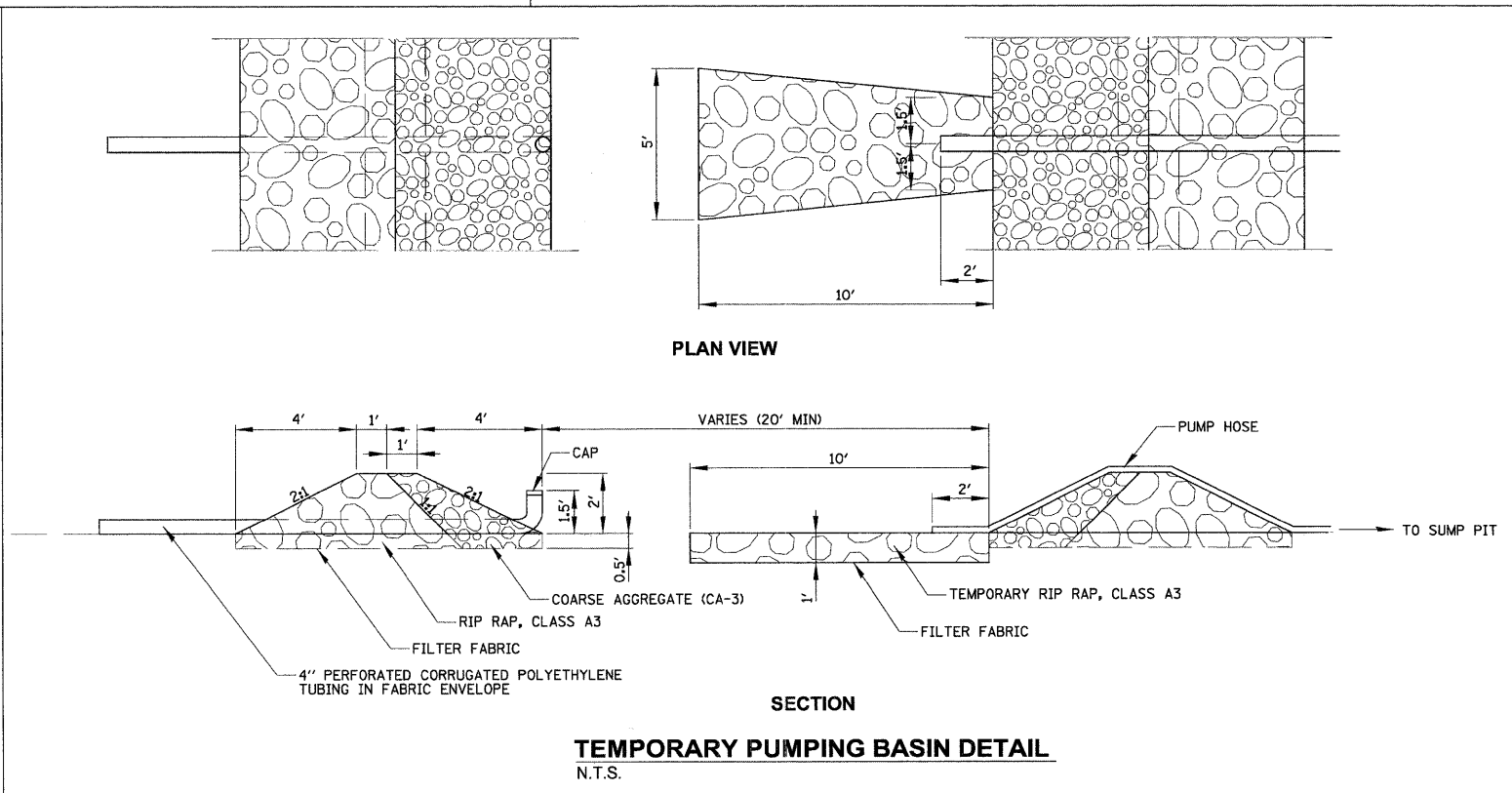
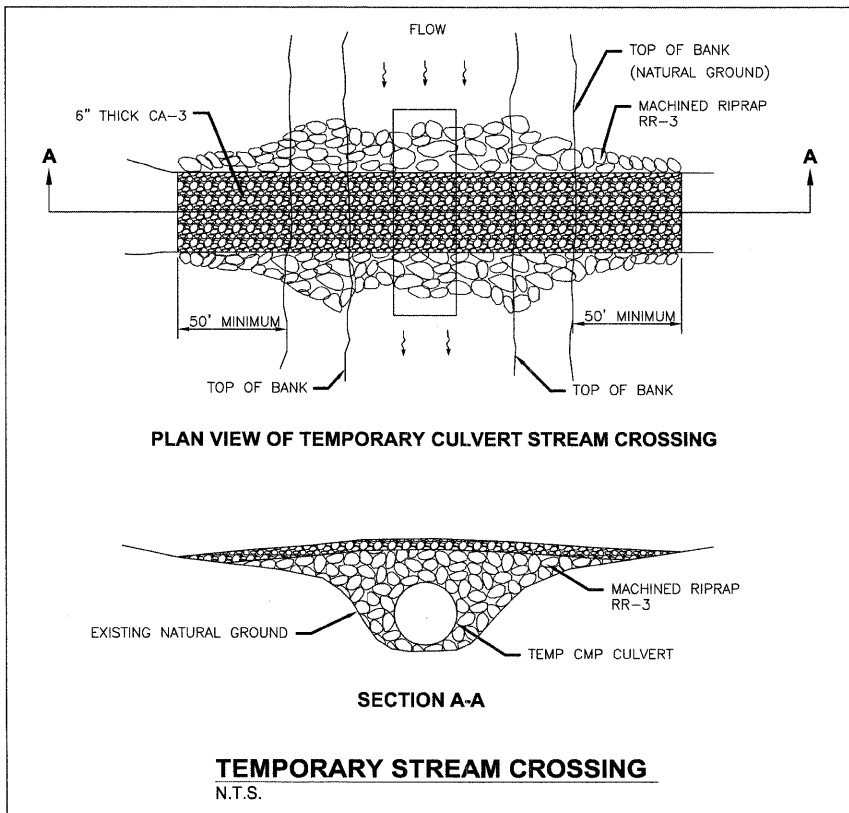
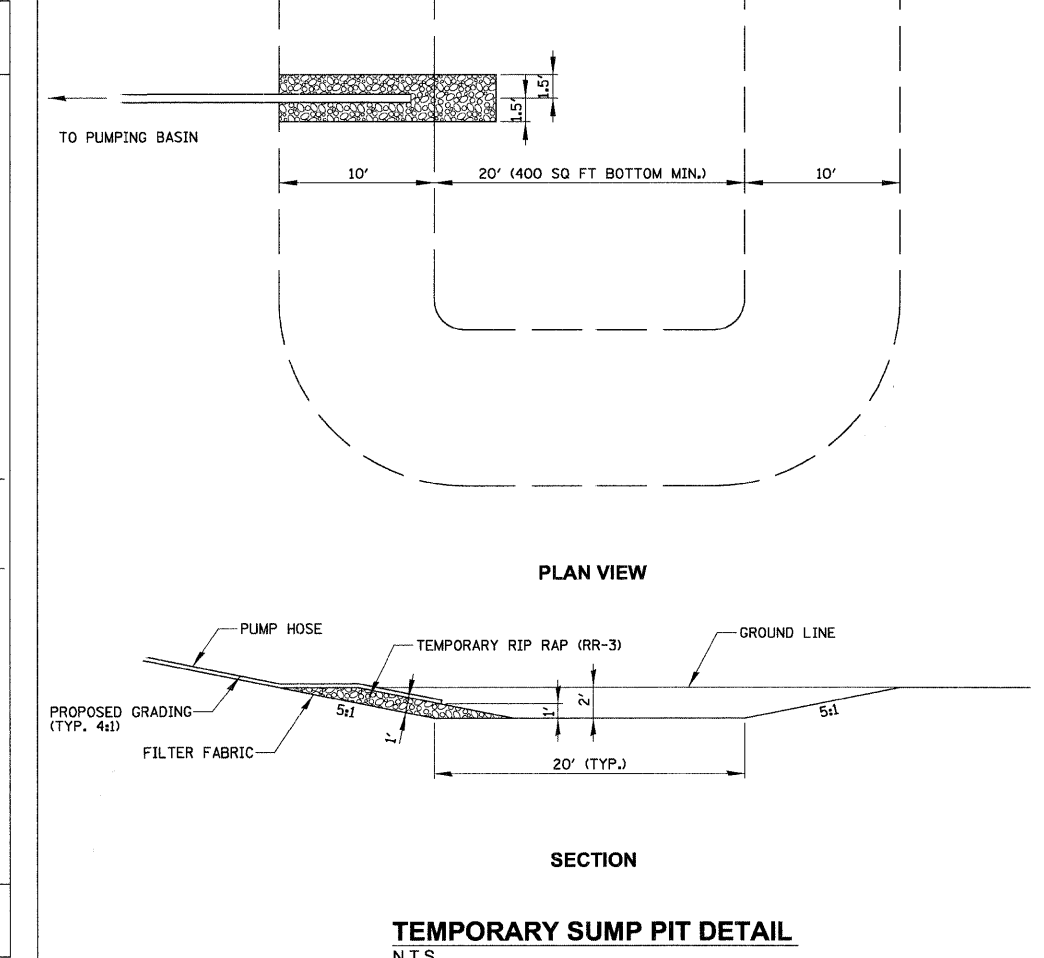
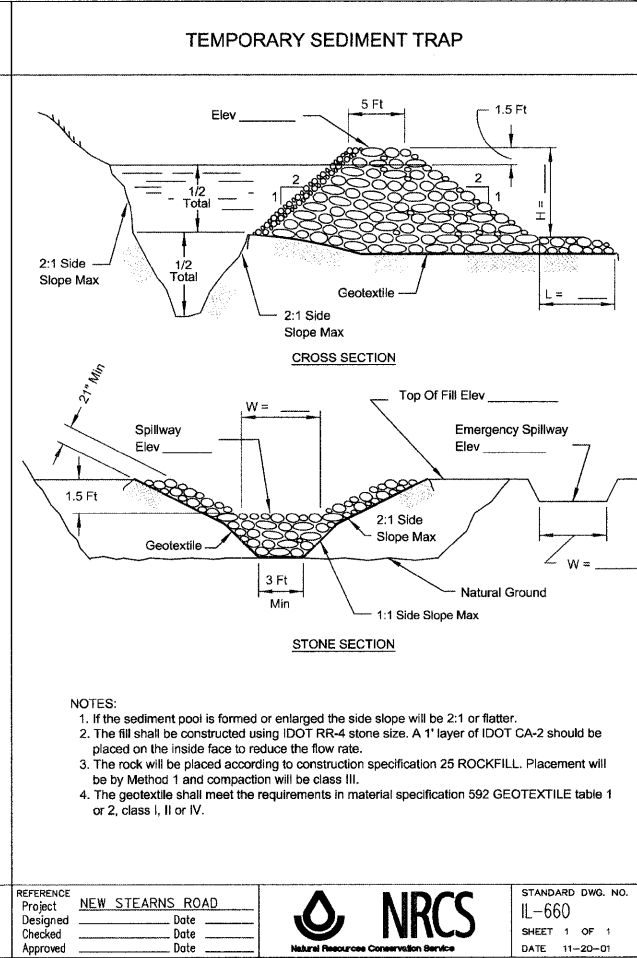
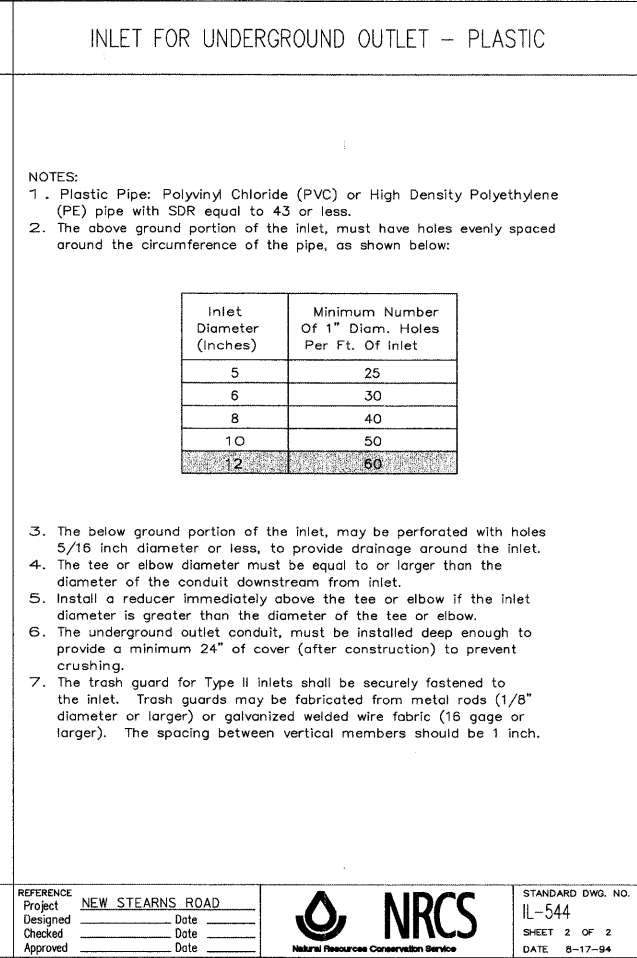
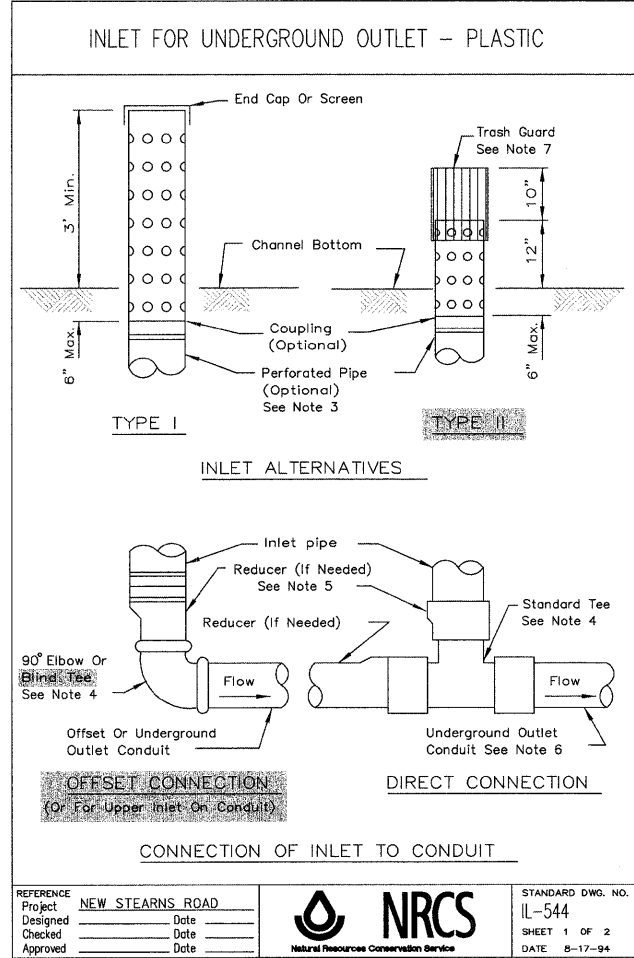

**STORM WATER POLLUTION PREVENTION PLAN (SWPPP):
STEARNS ROAD – RANDALL ROAD TO MCLEAN BOULEVARD**

THIS PLAN HAS BEEN PREPARED TO COMPLY WITH THE PROVISIONS OF THE NPDES PERMIT NUMBER ILR10 ISSUED BY THE ILLINOIS ENVIRONMENTAL PROTECTION AGENCY FOR STORM WATER DISCHARGES FROM CONSTRUCTION SITE ACTIVITIES.

1. SITE DESCRIPTION:

A. THE WORK UNDER THIS CONTRACT WILL BE COMPLETED ON PROPERTY LOCATED IN UNINCORPORATED ST. CHARLES TOWNSHIP, KANE COUNTY, ILLINOIS ALONG THE NEW STEARNS ROAD ALIGNMENT BETWEEN RANDALL ROAD AND MCLEAN BOULEVARD. THE PROJECT INCLUDES THE CLEARING OF THE SITE, FILLING OF EXISTING WETLANDS, CONSTRUCTION OF DETENTION BASINS, COMPENSATORY STORAGE AND THE BUILDING OF THE ROADWAY EMBANKMENT FOR NEW STEARNS ROAD.

B. THE FOLLOWING IS A DESCRIPTION OF THE INTENDED SEQUENCE OF THE MAJOR ACTIVITIES WHICH WILL DISTURB SOIL FOR MAJOR PORTIONS OF THE CONSTRUCTION SITE; SUCH AS EXCAVATION AND GRADING SEQUENCE OF THE CONSTRUCTION ACTIVITIES MAY BE AS FOLLOWS:

- i) INSTALLATION OF CONSTRUCTION FENCING, PERIMETER EROSION BARRIER AND VEGETATION
- ii) CLEARING OF THE PROJECT SITE AS SHOWN IN THE STAGING PLAN
- iii) GRADING OF DETENTION PONDS AND THE TEMPORARY DIVERSION CHANNEL.
- iv) TOPSOIL SPREADING WITH TEMPORARY OR PERMANENT SOIL STABILIZATION MEASURES AND THE CONSTRUCTION OF PERMANENT SOIL EROSION AND SEDIMENT CONTROL MEASURES
- v) REMOVAL OF TEMPORARY SOIL EROSION AND SEDIMENT CONTROL MEASURES

C. THE TOTAL AREA OF THE CONSTRUCTION SITE IS ESTIMATED TO BE 41 ACRES. THE APPROXIMATE TOTAL AREA OF THE SITE WILL BE DISTURBED BY EXCAVATION, GRADING OR OTHER ACTIVITIES.

D. THE ESTIMATED RUNOFF COEFFICIENT FOR THE PROJECT IS 0.79 FOR EXISTING CONDITIONS AND 0.42 FOR THE PROPOSED PROJECT. INFORMATION DESCRIBING THE SOILS AT THE SITE IS CONTAINED IN THE SOILS REPORTS FOR THE PROJECT, WHICH IS HEREBY INCORPORATED BY REFERENCE.

E. WATERS OF THE U.S. INCLUDED WITHIN OR ADJACENT TO THE PROJECT SITE IS THE FOX RIVER. THE SITE DISCHARGES TO AN UNAMED TRIBUTARY. THERE ARE WETLANDS WITHIN THE PROJECT SITE AND ON THE ADJACENT PROPERTIES. THE WETLAND BOUNDARIES ARE SHOWN ON THE LANDSCAPE RESTORATION & EROSION CONTROL PLAN SHEETS.

2. CONTROLS:

THIS SECTION OF THE PLAN ADDRESSES THE VARIOUS CONTROLS THAT WILL BE IMPLEMENTED FOR EACH OF THE MAJOR CONSTRUCTION ACTIVITIES DESCRIBED IN 1.B ABOVE. FOR EACH MEASURE DISCUSSED, THE CONTRACTOR WILL BE RESPONSIBLE FOR ITS IMPLEMENTATION AS INDICATED.

EACH CONTRACTOR HAS SIGNED THE REQUIRED CERTIFICATION ON FORMS WHICH ARE ATTACHED TO AND ARE A PART OF THIS PLAN.

THE LANDSCAPE RESTORATION & EROSION CONTROL PLAN DRAWINGS INCLUDED DEFINE THE SIZE AND LOCATION OF THE MEASURES TO BE INSTALLED DURING THE CONSTRUCTION OF THIS PROJECT.

A. SOIL EROSION AND SEDIMENT CONTROLS:

- i) **STABILIZATION PRACTICES:**
PROVIDED BELOW IS A DESCRIPTION OF INTERIM AND PERMANENT STABILIZATION PRACTICES INCLUDING SITE-SPECIFIC SCHEDULING OF THE IMPLEMENTATION OF THE PRACTICES. SITE PLANS WILL ENSURE THAT EXISTING VEGETATION IS PRESERVED WHERE ATTAINABLE AND DISTURBED PORTIONS OF THE SITE WILL BE STABILIZED.

EXCEPT AS PROVIDED IN 2.A.I AND 2.B, STABILIZATION MEASURES SHALL BE INITIATED ON A DAILY BASIS WHERE CONSTRUCTION ACTIVITIES HAVE TEMPORARILY OR PERMANENTLY CEASED, BUT IN NO CASE MORE THAN 7 DAYS AFTER THE CONSTRUCTION ACTIVITY IN THAT PORTION OF THE SITE HAS TEMPORARILY OR PERMANENTLY CEASED, OR ON ALL DISTURBED PORTIONS OF THE SITE WHERE CONSTRUCTION ACTIVITY WILL NOT OCCUR FOR A PERIOD OF 14 OR MORE CALENDAR DAYS.

WHERE THE INITIATION OF STABILIZATION MEASURES BY THE 7TH DAY AFTER CONSTRUCTION ACTIVITY TEMPORARILY OR PERMANENTLY CEASES IS PRECLUDED BY SNOW COVER, STABILIZATION SHALL BE INITIATED AS SOON AS PRACTICABLE THEREAFTER.

DESCRIPTION OF STABILIZATION PRACTICES:

1. DUST CONTROL WILL BE ACCOMPLISHED USING WATERING TRUCKS AS DIRECTED BY THE ENGINEER.
2. TEMPORARY STABILIZATION WITH STRAW MULCH WILL BE USED TO STABILIZE CONSTRUCTION AREAS WHERE CONSTRUCTION ACTIVITY IS HALTED FOR MORE THAN 14 DAYS. OR AREAS WHERE THE FINAL GRADE HAS BEEN REACHED BUT CANNOT BE PERMANENTLY STABILIZED DUE TO THE PLANTING SEASON RESTRICTIONS OF THE PERMANENT STABILIZATION.
3. EROSION CONTROL BLANKET WILL BE USED TO STABILIZE THE CONSTRUCTION AREAS WHERE THE FINAL GRADE HAS BEEN REACHED BUT CANNOT BE PERMANENTLY STABILIZED OR TREATED WITH TEMPORARY STABILIZATION WITH STRAW MULCH DUE TO THE PLANTING SEASON RESTRICTIONS.
4. TEMPORARY FENCING AND PERIMETER EROSION BARRIER, ROLLED EXCELSIOR WILL BE PLACED ALONG TREE STANDS TO BE PRESERVED AND TO PREVENT THE BUILD UP OF SEDIMENT ON TOP OF THE TREE ROOTS.
5. WATERS OF THE U.S. AND WETLANDS WITHIN OR ADJACENT TO THE PROJECT WILL BE PROTECTED WITH CONSTRUCTION FENCE AND PERIMETER EROSION BARRIER, ROLLED EXCELSIOR.
6. SHEET FLOWS EXITING THE SITE WILL ENCOUNTER PERIMETER EROSION BARRIER.
7. PUMPING BASINS, SUMP PITS, OR AN EQUIVALENT MEASURE WILL BE CONSTRUCTED AT ALL LOCATIONS WHERE THE WATER IS PUMPED. RIPRAP WILL BE CONSTRUCTED AT THE INTAKE HOSE AND DISCHARGE HOSE. PUMPING WILL ONLY BE PERMITTED AT THESE LOCATIONS.
8. TEMPORARY AGGREGATE BERMS, ROCK CHECK DAMS, OR AN EQUIVALENT MEASURE WILL BE USED TO SLOW DITCH FLOWS AND CONTROL SOIL EROSION.
9. STABILIZED CONSTRUCTION ENTRANCES WILL BE CONSTRUCTED AT ALL LOCATIONS WHERE CONSTRUCTION TRAFFIC ENTERS OR EXITS THE SITE.
10. STOCKPILES THAT ARE TO REMAIN IN PLACE FOR MORE THAN THREE DAYS SHALL HAVE SOIL EROSION AND SEDIMENT CONTROL PROVIDED. AT A MINIMUM, PERIMETER EROSION BARRIER WILL BE PLACED AROUND THE BOTTOM OF THE STOCKPILE.
11. TEMPORARY STREAM CROSSINGS WILL NOT BE ALLOWED, EXCEPT AS PROVIDED FOR IN THE U.S. ARMY CORP OF ENGINEERS 404 PERMIT.

ii) STRUCTURAL PRACTICES:

PROVIDED BELOW IS A DESCRIPTION OF STRUCTURAL PRACTICES THAT WILL BE IMPLEMENTED, TO THE DEGREE ATTAINABLE, TO DIVERT FLOWS FROM EXPOSED SOILS, STORE FLOWS, LIMIT RUNOFF AND THE DISCHARGE OF POLLUTANTS FROM EXPOSED AREAS OF THE SITE. THE INSTALLATION OF THESE DEVICES MAY BE SUBJECT TO SECTION 404 OF THE CLEAN WATER ACT.

1. INITIAL CONSTRUCTION (PRE-STAGE I) (SEE STORM WATER POLLUTION PREVENTION PLAN – CONSTRUCTION STAGING FOR MORE DETAILS.)

- * INSTALLATION OF TEMPORARY FENCE AND PERIMETER EROSION BARRIER, ROLLED EXCELSIOR ALONG TREE STANDS TO BE PRESERVED, WATERS OF THE U.S. AND WETLANDS
- * CONSTRUCTION OF VEGETATIVE BUFFERS AS SHOWN ON THE PLANS
- * REMOVE TREES AND OTHER STRUCTURES

2. DURING CONSTRUCTION

- * CLEAR SITE
- * CONSTRUCT DETENTION POND, COMPENSATORY STORAGE AREAS, THE TEMPORARY DIVERSION CHANNEL, AND ROCK CHECK DAMS.
- * COMPLETE EARTHWORK AND STORM SEWER INSTALLATION; CONSTRUCTION OF THE PERMANENT SOIL EROSION AND SEDIMENT CONTROL ITEMS
- * COMPLETE PERMANENT OR TEMPORARY SOIL STABILIZATION
- * REMOVE TEMPORARY SOIL EROSION AND SEDIMENT CONTROL MEASURES

3. POST CONSTRUCTION

- * MAINTENANCE OF VEGETATION AND PLANTINGS

B. STORM WATER MANAGEMENT

PROVIDED BELOW IS A DESCRIPTION OF MEASURES THAT WILL BE INSTALLED DURING THE CONSTRUCTION PROCESS TO CONTROL THE POLLUTANTS IN STORM WATER DISCHARGES THAT WILL OCCUR AFTER THE CONSTRUCTION OPERATIONS HAVE BEEN COMPLETED. THE INSTALLATION OF THESE DEVICES MAY BE SUBJECT TO SECTION 404 OF THE CLEAN WATER ACT.

- i) THE PRACTICES SELECTED FOR IMPLEMENTATION WERE DETERMINED ON THE BASIS OF TECHNICAL GUIDANCE CONTAINED IN THE IEPA'S ILLINOIS URBAN MANUAL AND OTHER ORDINANCES LISTED IN THE SPECIFICATIONS. THE STORM WATER POLLUTANT CONTROL MEASURES SHALL INCLUDE:

1. RIPRAP APRONS AT FLARED END SECTIONS
2. PIPE RESTRICTORS AND WEIRS IN DETENTION POND OUTFALLS
3. ROCK CHECK DAMS (LEAKY BERMS) BETWEEN COMPENSATORY STORAGE AREAS
4. TEMPORARY DIVERSION CHANNEL.
5. AGGREGATE BERMS ALONG NEW STEARNS ROAD EMBANKMENT
6. TEMPORARY CONCRETE WASHOUT FACILITY.
7. PERMANENT VEGETATION AND PLANTINGS

- ii) VELOCITY DISSIPATION DEVICES WILL BE PLACED AT DISCHARGE LOCATIONS AND ALONG THE LENGTH OF ANY OUTFALL CHANNEL AS NECESSARY TO PROVIDE A NON-EROSIVE VELOCITY FLOW FROM THE STRUCTURE TO A WATER COURSE SO THAT THE NATURAL, PHYSICAL, AND BIOLOGICAL CHARACTERISTICS AND FUNCTIONS ARE MAINTAINED AND PROTECTED (I.E., MAINTENANCE OF HYDROLOGIC CONDITIONS, SUCH AS THE HYDROPERIOD AND HYDRODYNAMICS PRESENT PRIOR TO THE INITIATION OF CONSTRUCTION ACTIVITIES). STORM WATER MANAGEMENT CONTROL INCLUDES:

1. RIPRAP APRONS AT FLARED END SECTIONS
2. AGGREGATE DITCH CHECKS
3. PERMANENT VEGETATION

C. OTHER CONTROLS:

- i) NON-HAZARDOUS WASTE DISPOSAL: THE SOLID WASTE MATERIALS INCLUDING TRASH, CONSTRUCTION DEBRIS, EXCESS CONSTRUCTION MATERIALS, MACHINERY, TOOLS AND OTHER ITEMS WILL BE COLLECTED AND DISPOSED OF OFF-SITE BY THE CONTRACTOR. THE CONTRACTOR IS RESPONSIBLE TO ACQUIRE ANY PERMIT REQUIRED FOR SUCH DISPOSAL. BURNING ON-SITE WILL NOT BE PERMITTED. NO SOLID MATERIALS, INCLUDING BUILDING MATERIALS, SHALL BE DISCHARGED INTO WATERS OF THE U.S., EXCEPT AS AUTHORIZED BY A SECTION 404 PERMIT.

- ii) HAZARDOUS WASTE DISPOSAL: SHALL CONFORM TO THE IDOT SPECIAL PROVISION.

- iii) SANITARY WASTE DISPOSAL: THE PROVISIONS OF THIS PLAN SHALL ENSURE AND DEMONSTRATE COMPLIANCE WITH THE APPLICABLE STATE AND/OR LOCAL WASTE DISPOSAL, SANITARY SEWER, OR SEPTIC SYSTEM REGULATIONS. THE CONTRACTOR SHALL NOT CREATE OR ALLOW UNSANITARY CONDITIONS.

- iv) OFF-SITE VEHICLE TRACKING: EACH SITE SHALL HAVE ONE OR MORE STABILIZED CONSTRUCTION ENTRANCES IN CONFORMANCE WITH THE PLAN DETAILS. WHERE THE CONTRACTOR'S EQUIPMENT IS OPERATED ON ANY PORTION OF THE TRAVELED SURFACE OR STRUCTURES USED BY TRAFFIC ON OR ADJACENT TO THE PROJECT, THE CONTRACTOR SHALL CLEAN (NOT FLUSHING OF) THE TRAVELED SURFACE OF ALL DIRT AND DEBRIS AT THE END OF EACH DAY'S OPERATIONS OR MORE FREQUENTLY IF DIRECTED BY THE ENGINEER.

- v) DEWATERING DEVICES: IF DEWATERING DEVICES ARE USED, DISCHARGE LOCATIONS SHALL BE PROTECTED FROM SOIL EROSION. ALL PUMPED DISCHARGES SHALL BE Routed THROUGH A SUMP PIT INTO A PUMPING BASIN, THROUGH A SILT BAG, OR DISCHARGED THROUGH A SILT TRAP PRIOR TO DISCHARGING FROM THE SITE.
- vi) SITE CLEANUP: TRAPPED SEDIMENT AND OTHER DISTURBED SOILS RESULTING FROM THE DISPOSITION OF TEMPORARY SOIL EROSION AND SEDIMENT CONTROL MEASURES SHALL BE PERMANENTLY STABILIZED TO PREVENT FURTHER SOIL EROSION AND SEDIMENTATION.

D. APPROVED COUNTY, STATE, OR LOCAL PLANS:

THE MANAGEMENT PRACTICES, CONTROLS, AND OTHER PROVISIONS CONTAINED IN THIS PLAN ARE AT LEAST AS PROTECTIVE AS THE REQUIREMENTS CONTAINED IN THE ILLINOIS ENVIRONMENTAL PROTECTION AGENCY'S ILLINOIS URBAN MANUAL STANDARDS AND SPECIFICATIONS. PROCEDURES AND REQUIREMENTS SPECIFIED IN APPLICABLE LANDSCAPE RESTORATION & EROSION CONTROL PLANS OR STORM WATER MANAGEMENT PLANS APPROVED BY LOCAL OFFICIALS SHALL BE DESCRIBED OR INCORPORATED BY REFERENCE BELOW. REQUIREMENTS SPECIFIED IN SOIL EROSION AND SEDIMENT CONTROL PLANS, SITE PERMITS, STORM WATER MANAGEMENT SITE PLANS, OR SITE PERMITS APPROVED BY COUNTY, STATE, OR LOCAL OFFICIALS THAT ARE APPLICABLE TO PROTECTING SURFACE WATER RESOURCES ARE, UPON SUBMITTAL OF A NOTICE OF INTENT (NOI), INCORPORATED AND ENFORCEABLE UNDER THIS PERMIT EVEN IF THEY ARE NOT SPECIFICALLY INCLUDED IN THE PLAN.

THE SOIL EROSION AND SEDIMENT CONTROL FOR THIS SITE MUST MEET THE REQUIREMENTS OF THE FOLLOWING AGENCIES:

KANE-DUPAGE SOIL AND WATER CONSERVATION DISTRICT
KANE COUNTY DIVISION OF TRANSPORTATION
KANE COUNTY FOREST PRESERVE DISTRICT
ILLINOIS DEPARTMENT OF TRANSPORTATION
ILLINOIS ENVIRONMENTAL PROTECTION AGENCY
U.S. ARMY CORP OF ENGINEERS

3. MAINTENANCE:

THE FOLLOWING IS A DESCRIPTION OF PROCEDURES THAT WILL BE USED TO MAINTAIN, IN GOOD AND EFFECTIVE OPERATING CONDITIONS, VEGETATION, SOIL EROSION AND SEDIMENT CONTROL MEASURES, AND OTHER PROTECTIVE MEASURES IDENTIFIED IN THIS PLAN AND STANDARD SPECIFICATIONS:

THE CONTRACTOR WILL ASSIGN A SOIL EROSION AND SEDIMENT CONTROL MANAGER (SESCM) TO THE PROJECT. HIS DUTIES WILL BE TO SUPERVISE THE MAINTENANCE OF THE SOIL EROSION AND SEDIMENT CONTROL MEASURES AND IMPLEMENTATION OF THIS PLAN.

THE FOLLOWING SHALL BE THE MINIMUM MAINTENANCE REQUIRED:

A. VEGETATIVE SOIL EROSION MEASURES – THE VEGETATIVE GROWTH OF TEMPORARY AND PERMANENT SEEDING, VEGETATIVE FILTERS, ETC., SHALL BE MAINTAINED PERIODICALLY AND SUPPLIED ADEQUATE WATERING AND FERTILIZER. THE VEGETATIVE COVER SHALL BE REMOVED AND RESEEDED AS NECESSARY.

B. PUMPING BASINS, TEMPORARY SILT TRAPS, OR ROCK CHECK DAMS SHALL BE CLEANED OF SEDIMENT WHEN THE SEDIMENT HAS REACHED A DEPTH OF 50% OF THE HEIGHT OF THE AGGREGATE BERM.

C. PERIMETER EROSION BARRIER WILL BE EXAMINED REGULARLY AND REPAIRED AS NECESSARY. SEDIMENT SHALL BE REMOVED WHEN IT REACHES A HEIGHT EQUAL TO 50% OF THE HEIGHT OF THE BARRIER.

D. TEMPORARY SEEDING FOR EROSION CONTROL WILL BE REPAIRED WHEN BARE STOPS AND WASHOUT OCCUR.

E. STABILIZED CONSTRUCTION ENTRANCES SHALL HAVE SEDIMENT BUILD UP REMOVED AS NECESSARY.

4. INSPECTIONS:

THE ENGINEER WILL BE RESPONSIBLE FOR CONDUCTING SOIL EROSION AND SEDIMENT CONTROL INSPECTIONS. THE CONTRACTOR'S SESCMM SHALL BE NOTIFIED WHEN THE INSPECTIONS ARE TO TAKE PLACE AND IS EXPECTED TO BE PRESENT DURING THE INSPECTIONS. A MAINTENANCE INSPECTION REPORT WILL BE COMPLETED AFTER EACH INSPECTION. A COPY OF THE REPORT IS TO BE COMPLETED BY THE INSPECTOR AND STORED ON-SITE WITH A COPY GIVEN TO THE CONTRACTOR.

THE INSPECTION SHALL INCLUDE ALL DISTURBED AREAS OF THE CONSTRUCTION SITE WHICH HAVE NOT BEEN FINALLY STABILIZED. THE STRUCTURAL CONTROL MEASURES, LOCATIONS WHERE VEHICLES ENTER OR EXIT THE SITE AND ALL MAJOR OUTFALLS. SUCH INSPECTION SHALL BE CONDUCTED AT LEAST ONCE EVERY SEVEN CALENDAR DAYS AND WITHIN 24 HOURS OF THE END OF A RAIN STORM (OR EQUIVALENT SNOWFALL) THAT IS 0.5 INCHES OR GREATER. DEPTH OF RAIN FALL WILL BE DETERMINED BY AN ON-SITE RAIN GAUGE. THE ENGINEER SHALL READ THE RAIN GAUGE DAILY AND AFTER EACH RAIN STORM.

A. DISTURBED AREAS AND AREAS USED FOR STORAGE OF MATERIALS THAT ARE EXPOSED TO PRECIPITATION SHALL BE INSPECTED FOR EVIDENCE OF, OR THE POTENTIAL FOR, POLLUTANTS ENTERING THE DRAINAGE SYSTEM AND WATERWAYS. SOIL EROSION AND SEDIMENT CONTROL MEASURES IDENTIFIED IN THE PLAN SHALL BE OBSERVED TO ENSURE THAT THEY ARE OPERATING CORRECTLY. IF REPAIR IS NECESSARY, IT WILL BE INITIATED WITHIN 24 HOURS OF THE COMPLETION OF THE INSPECTION REPORT. WHERE DISCHARGE LOCATIONS OR POINTS ARE ACCESSIBLE, THEY SHALL BE INSPECTED TO ASCERTAIN WHETHER THE MEASURES ARE EFFECTIVE IN PREVENTING SIGNIFICANT IMPACTS TO RECEIVING WATERS. LOCATIONS WHERE VEHICLES ENTER OR EXIT THE SITE SHALL BE INSPECTED FOR EVIDENCE OF OFF-SITE TRACKING.

B. BASED ON THE RESULTS OF THE INSPECTION, THE DESCRIPTION OF POTENTIAL POLLUTANT SOURCES IDENTIFIED IN SECTION 1 ABOVE AND POLLUTION PREVENTION MEASURES IDENTIFIED IN SECTION 2 ABOVE, THE STORM WATER POLLUTION PREVENTION PLAN SHALL BE REVISED AS APPROPRIATE AS SOON AS PRACTICABLE AFTER SUCH INSPECTION. ANY CHANGES TO THIS PLAN RESULTING FROM THE REQUIRED INSPECTION SHALL BE IMPLEMENTED WITHIN SEVEN CALENDAR DAYS FOLLOWING THE INSPECTION.

<p>Hey and Associates, Inc. Water Resources, Wetlands and Ecology</p>	USER NAME = #USER#	DESIGNED - BRO	REVISED -	<p>KANE COUNTY DEPARTMENT OF TRANSPORTATION</p>	<p>STORM WATER POLLUTION PREVENTION PLAN</p>	F.A.P. RTE.	SECTION	COUNTY	TOTAL SHEETS	SHEET NO.	
	PLLOT SCALE = #SCALE#	DRAWN - CFR	REVISED -			36I	06-00214-25-BR	KANE	220	60	
	PLLOT DATE = #DATE#	CHECKED - BRO	REVISED -			<p>STAGE 5</p>			<p>CONTRACT NO. 63076</p>		
		DATE - 03/30/09	REVISED -			SCALE: N.T.S.	SHEET NO. 1 OF 3 SHEETS	STA. TO STA.	FED. ROAD DIST. NO. 1	ILLINOIS	FED. AID PROJECT

C. A REPORT SUMMARIZING THE SCOPE OF THE INSPECTION, NAME(S) AND QUALIFICATIONS OF PERSONNEL MAKING THE INSPECTION, THE DATE(S) OF THE INSPECTION, MAJOR OBSERVATIONS RELATING TO THE IMPLEMENTATION OF THIS STORM WATER POLLUTION PREVENTION PLAN, AND ACTION TAKEN IN ACCORDANCE WITH SECTION 4.B SHALL BE MADE AND RETAINED AS PART AS PART OF THE PLAN FOR AT LEAST THREE YEARS AFTER THE DATE OF INSPECTION. THE REPORT SHALL BE SIGNED IN ACCORDANCE WITH PART VI.G OF THE GENERAL PERMIT. INSPECTION REPORTS WILL PROVIDE A RECORD OF THE DATES WHEN MAJOR GRADING ACTIVITIES OCCUR, WHEN CONSTRUCTION ACTIVITIES TEMPORARILY OR PERMANANTLY CEASE ON A PORTION OF THE SITE, AND WHEN STABILIZATION MEASURES ARE INITIATED.

D. IF ANY VIOLATIONS OF THE PROVISIONS OF THIS PLAN ARE IDENTIFIED DURING THE CONDUCT OF THE CONSTRUCTION WORK COVERED BY THIS PLAN, THE ENGINEER SHALL COMPLETE AND FILE AN "INCIDENCE OF NONCOMPLIANCE" (ION) REPORT FOR THE IDENTIFIED VIOLATION. THE ENGINEER SHALL USE FORMS PROVIDED BY THE ILLINOIS ENVIRONMENTAL PROTECTION AGENCY AND SHALL INCLUDE SPECIFIC INFORMATION ABOUT THE CAUSE OF NONCOMPLIANCE, ACTIONS WHICH WERE TAKEN TO PREVENT ANY FURTHER CAUSES OF NONCOMPLIANCE, AND A STATEMENT DETAILING ANY ENVIRONMENTAL IMPACT WHICH MAY HAVE RESULTED FROM THE NON COMPLIANCE. ALL REPORTS OF NONCOMPLIANCE SHALL BE SIGNED BY A RESPONSIBLE AUTHORITY IN ACCORDANCE WITH PART VI.G OF THE GENERAL PERMIT. THE REPORT OF NONCOMPLIANCE SHALL BE MAILED TO THE FOLLOWING ADDRESS:

ILLINOIS ENVIRONMENTAL PROTECTION AGENCY
 DIVISION OF WATER POLLUTION CONTROL
 COMPLIANCE ASSURANCE SECTION #19
 1021 NORTH GRAND EAST
 P.O. BOX 19276
 SPRINGFIELD, IL 62794-9276

5. NON-STORM WATER DISCHARGES:

EXCEPT FOR FLOWS FROM FIRE FIGHTING ACTIVITIES, SOURCES OF NON-STORM WATER THAT MAY BE COMBINED WITH STORM WATER DISCHARGES ARE TREATED BY THE MEASURES INCLUDED IN THIS PLANS. THESE SOURCES INCLUDE THE FOLLOWING:

- * WATER USED TO WASH VEHICLES
- * WATER USED TO CONTROL DUST
- * PAVEMENT WASH WATERS WHERE SPILLS OR LEAKS OF TOXIC OR HAZARDOUS MATERIALS HAVE NOT OCCURRED (UNLESS SPILLED MATERIALS HAVE BEEN REMOVED)
- * IRRIGATION DITCHES
- * UNCONTAMINATED GROUND WATER
- * FOUNDATION OR FOOTING DRAINS WHERE FLOWS ARE NOT CONTAMINATED WITH PROCESS MATERIALS SUCH AS SOLVENTS

6. INVENTORY FOR POLLUTION PREVENTION PLAN:

THE MATERIALS OR SUBSTANCES LISTED BELOW ARE EXPECTED TO BE PRESENT ON SITE DURING CONSTRUCTION.
 (TABLE TO BE FILLED IN BY CONTRACTOR).

7. SPILL PREVENTION - MATERIAL MANAGEMENT PRACTICES:

THE FOLLOWING ARE THE MATERIAL MANAGEMENT PRACTICES THAT WILL BE USED TO REDUCE THE RISK OF SPILLS OR OTHER ACCIDENTAL EXPOSURE OF MATERIALS AND SUBSTANCES TO STORMWATER RUNOFF.

GOOD HOUSEKEEPING:

THE FOLLOWING GOOD HOUSEKEEPING PRACTICES WILL BE FOLLOWED ON SITE DURING THE CONSTRUCTION PROJECT:

- * AN EFFORT WILL BE MADE TO STORE ONLY ENOUGH PRODUCT REQUIRED TO DO THE JOB.
- * ALL MATERIALS STORED ON SITE WILL BE STORED IN A NEAT, ORDERLY MANNER IN THEIR APPROPRIATE CONTAINERS AND, IF POSSIBLE, UNDER A ROOF OR OTHER ENCLOSURE.
- * PRODUCTS WILL BE KEPT IN THEIR ORIGINAL CONTAINERS WITH THE ORIGINAL MANUFACTURER'S LABEL.
- * SUBSTANCES WILL NOT BE MIXED WITH ONE ANOTHER UNLESS RECOMMENDED BY THE MANUFACTURER.
- * THE SITE SUPERINTENDENT WILL INSPECT DAILY TO ENSURE PROPER USE AND DISPOSAL OF MATERIALS ON SITE.
- * WHENEVER POSSIBLE, ALL OF A PRODUCT WILL BE USED UP BEFORE DISPOSING OF THE CONTAINER.
- * MANUFACTURERS' RECOMMENDATIONS FOR PROPER USE AND DISPOSAL WILL BE FOLLOWED.

HAZARDOUS PRODUCTS:

THESE PRACTICES ARE USED TO REDUCE THE RISK ASSOCIATED WITH HAZARDOUS MATERIALS:

- * PRODUCTS WILL BE KEPT IN ORIGINAL CONTAINERS UNLESS THEY ARE NOT RESEALABLE.
- * ORIGINAL LABELS AND MATERIAL SAFETY DATA WILL BE RETAINED.
- * IF SURPLUS PRODUCT MUST BE DISPOSED OF, MANUFACTURES OR LOCAL AND STATE RECOMMENDED METHODS FOR PROPER DISPOSAL WILL BE FOLLOWED.

SPILL CONTROL PRACTICES:

IN ADDITION TO THE GOOD HOUSEKEEPING AND MATERIAL MANAGEMENT PRACTICES DISCUSSED IN THE PREVIOUS SECTIONS OF THIS PLAN, THE FOLLOWING PRACTICES WILL BE FOLLOWED FOR SPILL PREVENTION AND CLEANUP:

- * MANUFACTURER'S RECOMMENDED METHODS FOR SPILL CLEANUP WILL BE CLEARLY POSTED AND SITE PERSONNEL WILL BE MADE AWARE OF THE PROCEDURES AND THE LOCATION OF THE INFORMATION AND CLEANUP SUPPLIES.
- * MATERIALS AND EQUIPMENT NECESSARY FOR SPILL CLEANUP WILL BE KEPT IN THE MATERIAL STORAGE AREA ON SITE. EQUIPMENT AND MATERIALS WILL INCLUDE, BUT NOT BE LIMITED TO, BROOMS, DUST PANS, MOPS, RAGS, GLOVES, GOGGLES, KITTY LITTER, SAND, SAWDUST AND PLASTIC AND METAL TRASH CONTAINERS SPECIFICALLY FOR THIS PURPOSE.
- * ALL SPILLS WILL BE CLEANED UP IMMEDIATELY AFTER DISCOVERY.
- * THE SPILL AREA WILL BE KEPT WELL VENTILATED AND PERSONNEL WILL WEAR APPROPRIATE PROTECTIVE CLOTHING TO PREVENT INJURY FROM CONTACT WITH HAZARDOUS SUBSTANCES.
- * SPILLS OF TOXIC OR HAZARDOUS MATERIAL WILL BE REPORTED TO THE APPROPRIATE STATE OR LOCAL GOVERNMENT AGENCY, REGARDLESS OF SIZE.
- * THE SPILL PREVENTION PLAN WILL BE ADJUSTED TO INCLUDE MEASURES TO PREVENT THIS TYPE OF SPILL FROM RECURRING AND HOW TO CLEAN UP THE SPILL IF THERE IS ONE. A DESCRIPTION OF THE SPILL, WHAT CAUSED IT AND THE CLEANUP MEASURES WILL ALSO BE INCLUDED.
- * THE CONTRACTOR SHALL BE RESPONSIBLE FOR DAY-TO-DAY OPERATIONS AND WILL BE THE SPILL PREVENTION AND CLEANUP COORDINATOR. HE WILL DESIGNATE AT LEAST TWO OTHER SITE PERSONNEL WHO WILL RECEIVE SPILL PREVENTION AND CLEANUP TRAINING. THESE INDIVIDUALS WILL EACH BECOME RESPONSIBLE FOR A PARTICULAR PHASE OF PREVENTION AND CLEANUP. THE NAMES OF RESPONSIBLE SPILL PERSONNEL, LISTED BELOW, WILL BE POSTED IN THE MATERIAL STORAGE AREA AND IN THE OFFICE TRAILER ONSITE.

EPA SPILL RESPONSE # (217) 782-3637

NAME: _____ CONTRACTOR: _____

NAME: _____ CONTRACTOR: _____

KANE-DUPAGE SOIL & WATER CONSERVATION DISTRICT STANDARD NOTES:

UNLESS OTHERWISE INDICATED, ALL VEGETATIVE AND STRUCTURAL EROSION AND SEDIMENT CONTROL PRACTICES WILL BE CONSTRUCTD ACCORDING TO MINIMUM STANDARDS AND SPECIFICATIONS IN THE ILLINOIS URBAN MANUAL REVISED FEBRUARY 2002.

THE KANE-DUPAGE SOIL AND WATER CONSERVATION DISTRICT (KDSWCD) MUST BE NOTIFIED ONE WEEK PRIOR TO THE PRE-CONSTRUCTION CONFERENCE, ONE WEEK PRIOR TO THE COMMENCEMENT OF LAND DISTURBING ACTIVITIES, AND ONE WEEK PRIOR TO THE FINAL INSPECTION. TELEPHONE: (630) 584-7961 EXT. 3

A COPY OF THE APPROVED EROSION AND SEDIMENT CONTROL PLAN SHALL BE MAINTAINED ON THE SITE AT ALL TIMES.

PRIOR TO COMMENCING LAND-DISTURBING ACTIVITIES IN AREAS OTHER THAN INDICATED ON THESE PLANS (INCLUDING BUT NOT LIMITED TO, ADDITIONAL PHASES OF DEVELOPMENT AND OFF-SITE BORROW OR WASTE AREAS) A SUPPLEMENTARY EROSION CONTROL PLAN SHALL BE SUBMITTED TO THE OWNER FOR REVIEW BY THE KDSWCD.

THE CONTRACTOR IS RESPONSIBLE FOR INSTALLATION OF ANY ADDITIONAL EROSION CONTROL MEASURES NECESSARY TO PREVENT EROSION AND SEDIMENTATION AS DETERMINED BY THE KDSWCD.

DURING DEWATERING OPERATIONS, WATER WILL BE PUMPED INTO SEDIMENT BASINS OR SILT TRAPS. DEWATERING DIRECTLY INTO FIELD TILES OR STORMWATER STRUCTURES IS PROHIBITED.

ALSO, PLEASE ADD NOTE TO STATE THAT, IT IS THE RESPONSIBILITY OF THE LANDOWNER AND/OR GENERAL CONTRACTOR TO INFORM ANY SUB-CONTRACTOR(S) WHO MAY PERFORM WORK ON THIS PROJECT, OF THE REQUIREMENTS IN IMPLEMENTING AND MAINTAINING THESE EROSION CONTROL PLANS AND THE NATIONAL POLLUTANT DISCHARGE ELIMINATION SYSTEM (NPDES) PERMIT REQUIREMENTS SET FORTH BY THE ILLINOIS EPA.

NO WORK SHALL BE PERFORMED IN FLOWING WATER. WORK IN AND NEAR THE CRITICAL AREAS SHOULD BE DIVERTED AROUND THE WORK AREA OR ISOLATED FROM STREAM FLOWS USING A NON-ERODABLE COFFER DAM. THE STREAM BANKS SHOULD BE STABILIZED AT THE END OF EACH DAY. ONCE WORK IN THIS AREA BEGINS, PRIORITY SHALL BE GIVEN TO THE COMPLETION OF THE WORK AND FINAL STABILIZATION OF ALL DISTURBED AREAS. THE KDSWCD MUST BE IN AGREEMENT WITH OVERALL EXACT METHOD OF DIVERSION/ISOLATION PRIOR TO THE COMMENCEMENT OF CONSTRUCTION.

THIS PLAN HAS BEEN PREPARED TO COMPLY WITH THE PROVISIONS OF THE NPDES PERMIT NUMBER ILR10, ISSUED BY THE ILLINOIS ENVIRONMENTAL PROTECTION AGENCY FOR STORM WATER DISCHARGES FROM CONSTRUCTION SITE ACTIVITIES.

I CERTIFY UNDER PENALTY OF LAW THAT THIS DOCUMENT AND ALL ATTACHMENTS WERE PREPARED UNDER MY DIRECTION OR SUPERVISION IN ACCORDANCE WITH A SYSTEM DESIGNED TO ASSURE THAT QUALIFIED PERSONNEL PROPERLY GATHERED AND EVALUATED THE INFORMATION SUBMITTED. BASED ON MY INQUIRY OF THE PERSON OR PERSONS WHO MANAGE THE SYSTEM, OR THOSE PERSONS DIRECTLY RESPONSIBLE FOR GATHERING THE INFORMATION, THE INFORMATION SUBMITTED IS, TO THE BEST OF MY KNOWLEDGE AND BELIEF, TRUE, ACCURATE AND COMPLETE. I AM AWARE THAT THERE ARE SIGNIFICANT PENALTIES FOR SUBMITTING FALSE INFORMATION, INCLUDING THE POSSIBILITY OF FINE AND IMPRISONMENT FOR KNOWING VIOLATIONS.

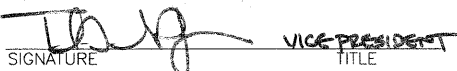
 SIGNATURE _____ TITLE VICE PRESIDENT DATE 4/23/09
 HEY AND ASSOCIATES, INC.
 COMPANY _____

CONTRACTOR CERTIFICATION STATEMENT

ALL CONTRACTORS AND SUBCONTRACTORS IDENTIFIED IN THE STORM WATER POLLUTION PREVENTION PLAN SHALL SIGN A COPY OF THE FOLLOWING CERTIFICATION STATEMENT BEFORE CONDUCTING ANY PROFESSIONAL SERVICE AT THE SITE IDENTIFIED IN THE STORM WATER POLLUTION PREVENTION PLAN.

I CERTIFY UNDER PENALTY OF LAW THAT I UNDERSTAND THE TERMS AND CONDITIONS OF THE GENERAL NATIONAL POLLUTANT DISCHARGE ELIMINATION SYSTEM (NPDES) PERMIT (ILR10) THAT AUTHORIZES THE STORM WATER DISCHARGES ASSOCIATED WITH INDUSTRIAL ACTIVITY FROM THE CONSTRUCTION SITE IDENTIFIED AS PART OF THIS CERTIFICATION.

SIGNATURE _____ TITLE _____ DATE _____

COMPANY _____

CONTRACTOR CERTIFICATION STATEMENT

ALL CONTRACTORS AND SUBCONTRACTORS IDENTIFIED IN THE STORM WATER POLLUTION PREVENTION PLAN SHALL SIGN A COPY OF THE FOLLOWING CERTIFICATION STATEMENT BEFORE CONDUCTING ANY PROFESSIONAL SERVICE AT THE SITE IDENTIFIED IN THE STORM WATER POLLUTION PREVENTION PLAN.

I CERTIFY UNDER PENALTY OF LAW THAT I UNDERSTAND THE TERMS AND CONDITIONS OF THE GENERAL NATIONAL POLLUTANT DISCHARGE ELIMINATION SYSTEM (NPDES) PERMIT (ILR10) THAT AUTHORIZES THE STORM WATER DISCHARGES ASSOCIATED WITH INDUSTRIAL ACTIVITY FROM THE CONSTRUCTION SITE IDENTIFIED AS PART OF THIS CERTIFICATION.

SIGNATURE _____ TITLE _____ DATE _____

COMPANY _____

CONTRACTOR CERTIFICATION STATEMENT

ALL CONTRACTORS AND SUBCONTRACTORS IDENTIFIED IN THE STORM WATER POLLUTION PREVENTION PLAN SHALL SIGN A COPY OF THE FOLLOWING CERTIFICATION STATEMENT BEFORE CONDUCTING ANY PROFESSIONAL SERVICE AT THE SITE IDENTIFIED IN THE STORM WATER POLLUTION PREVENTION PLAN.

I CERTIFY UNDER PENALTY OF LAW THAT I UNDERSTAND THE TERMS AND CONDITIONS OF THE GENERAL NATIONAL POLLUTANT DISCHARGE ELIMINATION SYSTEM (NPDES) PERMIT (ILR10) THAT AUTHORIZES THE STORM WATER DISCHARGES ASSOCIATED WITH INDUSTRIAL ACTIVITY FROM THE CONSTRUCTION SITE IDENTIFIED AS PART OF THIS CERTIFICATION.

SIGNATURE _____ TITLE _____ DATE _____

COMPANY _____

GENERAL SEQUENCE OF WORK
STORM WATER POLLUTION PREVENTION CONSTRUCTION STAGING BETWEEN RANDALL ROAD
AND MCLEAN BOULEVARD

1. INSTALL PERIMETER EROSION BARRIER
2. INSTALL TEMPORARY CULVERTS
3. INSTALL CONSTRUCTION ENTRANCE
4. CONSTRUCTION OF TEMPORARY DIVERSION CHANNEL
5. SITE CLEARING AND GRUBBING
6. CONSTRUCTION OF POND 2A
7. COMPLETE EARTHWORK AND INSTALL ROCK CHECK DAMS
8. INSTALL STORM SEWER
9. CONSTRUCT THE PERMANENT SOIL EROSION AND SEDIMENT CONTROL ITEMS.
GRAVITY STORM SEWER OUTLETS SHALL BE BLOCKED UNTIL PERMANENT SOIL
STABILIZATION HAS OCCURRED.
10. COMPLETE THE PERMANENT SOIL STABILIZATION.
11. REMOVE THE TEMPORARY SOIL EROSION AND SEDIMENT CONTROL ITEMS AND
PUMPING BASINS AND SUMP PITS.

CONSTRUCTION OF TEMPORARY DIVERSION CHANNEL

- 4A. STABILIZE EXISTING SOUTHERN CHANNEL BETWEEN APPROXIMATELY 503+50 AND
THE EXISTING WETLAND WITH RIPRAP. PROTECT PERIMETER OF CHANNEL WITH
SILT FENCE.
- 4B. DIVERT FLOW FROM NORTH ("FEN FLOW" COMING FROM 60" CULVERT UNDER
RR TRACKS) INTO STABILIZED SOUTHERN CHANNEL.
- 4C. COMPLETE NECESSARY GRADING TO INSTALL STORM SEWER FROM RR CULVERT
TO WETLAND.
- 4D. DIVERT "FEN FLOW" INTO STORM SEWER.

NOTES FOR CONSTRUCTION STAGING:

THE CONTRACTOR WILL BE PERMITTED TO BORROW AND/OR STOCKPILE IN AREAS OUTSIDE
OF THE CURRENT STAGE OF CONSTRUCTION PROVIDED SOIL EROSION AND SEDIMENT
CONTROL MEASURES ARE PROVIDED AT THE BORROW OR STOCKPILE SITE: THE
CONTRACTOR'S LANDSCAPE RESTORATION & EROSION CONTROL PLAN MUST BE APPROVED
PRIOR TO WORK BEGINNING AT THE BORROW OR STOCKPILE SITE.

PUMPING BASINS, IF TO BE UTILIZED, SHALL BE CONSTRUCTED PRIOR TO BEGINNING
CONSTRUCTION OF EACH DETENTION POND. THE BASIN SHALL NOT BE REMOVED UNTIL
THE SOIL HAS BEEN STABILIZED. ALL WATER SHALL BE PUMPED DIRECTLY INTO A
PUMPING BASIN OR EQUIVALENT MEASURE FROM A SUMP LOCATED WITHIN THE WORK
ZONE.

THE SOIL IN THE DOWNSTREAM DETENTION PONDS SHALL BE EITHER PERMANENTLY OR
TEMPORARILY STABILIZED PRIOR TO STARTING ANY UPSTREAM CONSTRUCTION. THE TYPE
OF STABILIZATION REQUIRED WILL BE BASED ON THE PLANTING SEASON FOR THE
PERMANENT STABILIZATION METHOD SHOWN ON THE LANDSCAPING PLANS AND THE TIME
OF YEAR WORK HAS BEEN COMPLETED. THE TYPE OF STABILIZATION WILL BE APPROVED
BY THE ENGINEER PRIOR TO CONSTRUCTION.

Hey and Associates, Inc. Water Resources, Wetlands and Ecology	USER NAME = \$USER\$	DESIGNED - BRO	REVISED -	KANE COUNTY DEPARTMENT OF TRANSPORTATION	STORM WATER POLLUTION PREVENTION PLAN STAGE 5	F.A.P. RTE.	SECTION	COUNTY	TOTAL SHEETS	SHEET NO.
	PLOT SCALE = \$SCALE\$	CHECKED - BRO	REVISED -			36I	06-00214-25-BR	KANE	220	62
	PLOT DATE = \$DATE\$	DATE - 03/30/09	REVISED -			CONTRACT NO. 63076				
	SCALE: N.T.S.		SHEET NO. 3 OF 3 SHEETS			STA. TO STA.	FED. ROAD DIST. NO. 1	ILLINOIS	FED. AID PROJECT	

- 1 STA. 469+35, 60.0' RT.
PRC FLAR END SEC 24"
INV = 796.50 (24" NW)
- 2 STA. 469+50, 50.0' RT.
RD MAN 5 DIA TIF CL
RIM = 801.56
INV = 796.66 (24" N)
INV = 796.56 (24" SE)
- 3 STA. 473+00, 50.0' RT.
RD MAN 5 DIA TIF CL
RIM = 802.86
INV = 798.14 (24" N)
INV = 798.04 (24" S)
- 4 STA. 476+00, 50.0' RT.
RD MAN 5 DIA TIF CL
RIM = 803.67
INV = 799.42 (24" N)
INV = 799.32 (24" S)

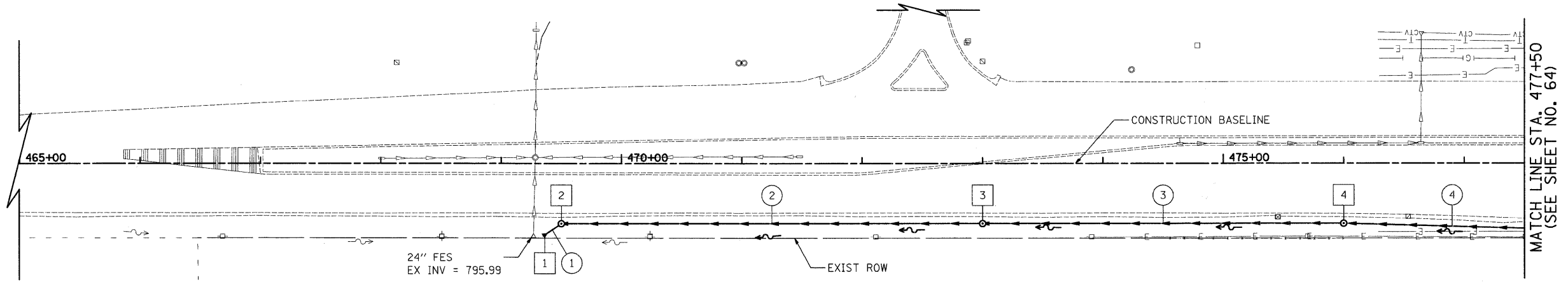

- 1 10' - STORM SEW CL A 1, 24" @ 0.40%
T.B.F. = 0.0 CU. YD.
- 2 345' - STORM SEW CL A 1, 24" @ 0.40%
T.B.F. = 0.0 CU. YD.
- 3 295' - STORM SEW CL A 1, 24" @ 0.40%
T.B.F. = 0.0 CU. YD.
- 4 176' - STORM SEW CL A 1, 24" @ 0.40%
T.B.F. = 0.0 CU. YD.

NOTES
THE STATION AND OFFSET CALL-OUT FOR FLARED
END SECTIONS IS MEASURED FROM THE TOE.

RANDALL ROAD

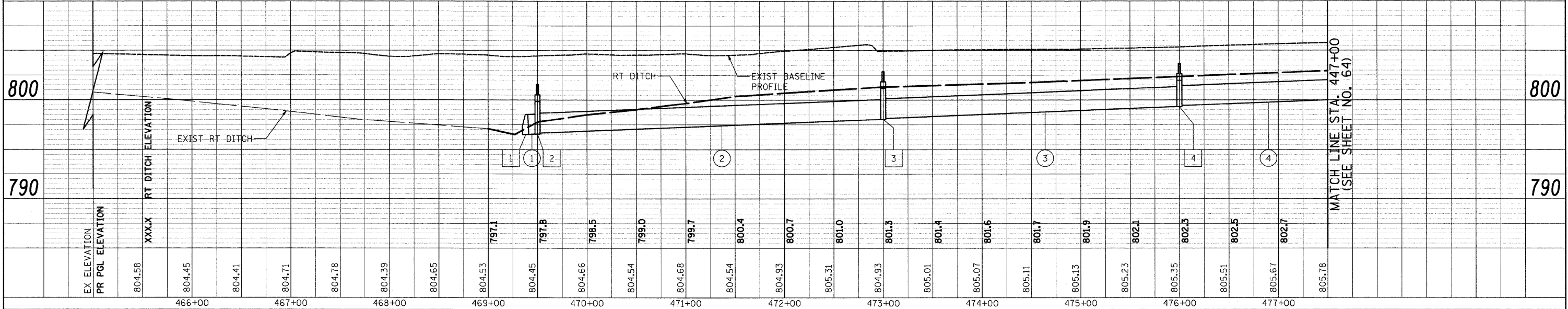

PLAN	REVISED	DATE
NO.	NO.	NO.

PROFILE	REVISED	DATE
NO.	NO.	NO.

FILE NAME =	USER NAME = mjp	DESIGNED - MJP	REVISED -	KANE COUNTY DIVISION OF TRANSPORTATION	DRAINAGE AND UTILITIES - RANDALL ROAD	F.A. RT. E. 361	SECTION 06-00214-25-BR	COUNTY KANE	TOTAL SHEETS 220	SHEET NO. 63
PLOT SCALE = 50.0000' / IN.	DRAWN - MJP	REVISIONS	CONTRACT NO. 63076							
PLOT DATE = 3/27/2009	CHECKED - DNM	REVISIONS								
	DATE - 3/30/09	REVISIONS								
SCALE: 1"=50'						SHEET NO. 1 OF 14 SHEETS		STA. 465+00 TO STA. 477+50		FED. ROAD DIST. NO. 1 ILLINOIS FED. AID PROJECT

DATE	
BY	
REVIEWED	
FLOW	
ALIGNMENT	CHECKED
NOTE BOOK	CHECKED
NO.	
NO.	
NO.	

DATE	
BY	
REVIEWED	
GRADES	CHECKED
STRUCTURE	NOTED
NO.	
NO.	
NO.	

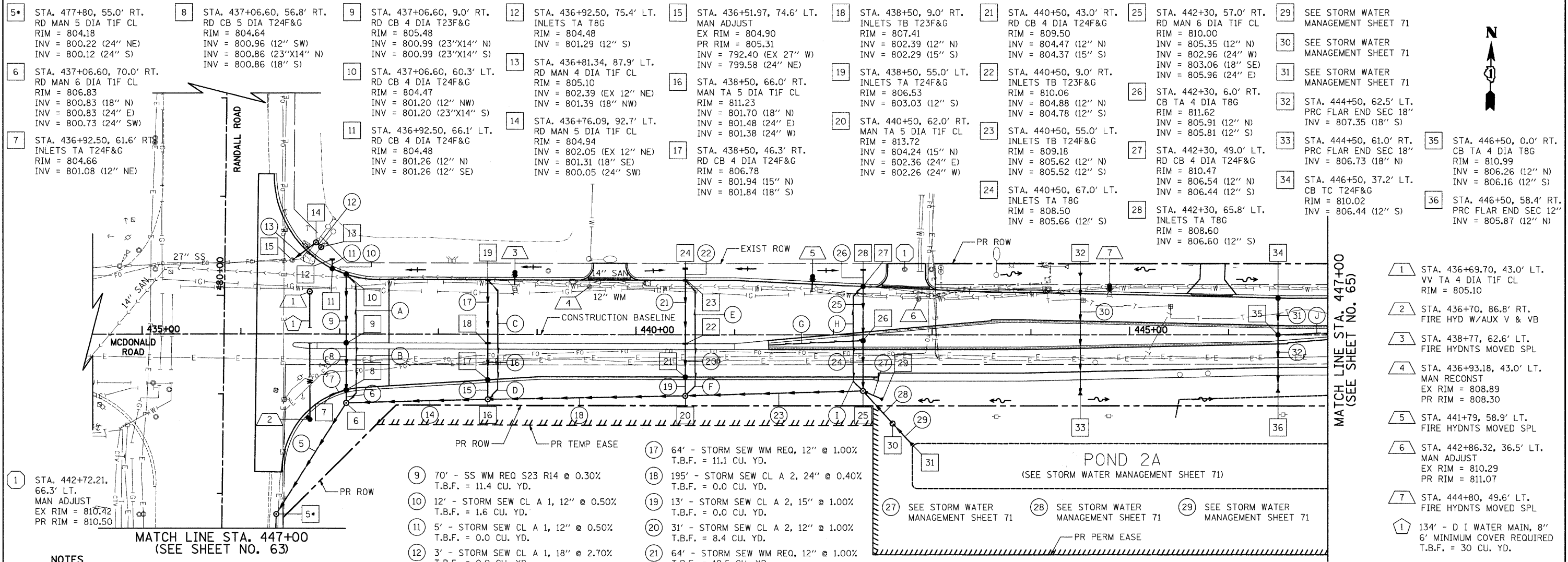

- NOTES**
- THE STATION AND OFFSET CALL-OUT FOR FLARED END SECTIONS IS MEASURED FROM THE TOE.
- THE STATION AND OFFSET CALL-OUT FOR DRAINAGE STRUCTURE 5 IS WITH RESPECT TO THE RANDALL ROAD ALIGNMENT.
- 1 STA. 442+72.21, 66.3' LT. MAN ADJUST EX RIM = 810.42 PR RIM = 810.50
 - 2 STA. 436+70, 86.8' RT. FIRE HYD W/AUX V & VB
 - 3 STA. 438+77, 62.6' LT. FIRE HYDNTS MOVED SPL
 - 4 STA. 436+93.18, 43.0' LT. MAN RECONST EX RIM = 808.89 PR RIM = 808.30
 - 5 STA. 441+79, 58.9' LT. FIRE HYDNTS MOVED SPL
 - 6 STA. 442+86.32, 36.5' LT. MAN ADJUST EX RIM = 810.29 PR RIM = 811.07
 - 7 STA. 444+80, 49.6' LT. FIRE HYDNTS MOVED SPL
 - 1 134' - D I WATER MAIN, 8" 6' MINIMUM COVER REQUIRED T.B.F. = 30 CU. YD.
 - 5 127' - STORM SEW CL A 2, 24" @ 0.40% T.B.F. = 0.0 CU. YD.
 - 6 6' - STORM SEW CL A 2, 18" @ 0.50% T.B.F. = 0.0 CU. YD.
 - 7 12' - STORM SEW CL A 1, 12" @ 1.00% T.B.F. = 1.6 CU. YD.
 - 8 44' - SS 2 RCEP S23 R14 @ 0.30% T.B.F. = 8.4 CU. YD.
 - 9 70' - SS WM REQ S23 R14 @ 0.30% T.B.F. = 11.4 CU. YD.
 - 10 12' - STORM SEW CL A 1, 12" @ 0.50% T.B.F. = 1.6 CU. YD.
 - 11 5' - STORM SEW CL A 1, 12" @ 0.50% T.B.F. = 0.0 CU. YD.
 - 12 3' - STORM SEW CL A 1, 18" @ 2.70% T.B.F. = 0.0 CU. YD.
 - 13 25' - STORM SEW CL A 2, 24" @ 1.90% T.B.F. = 5.0 CU. YD.
 - 14 138' - STORM SEW CL A 2, 24" @ 0.40% T.B.F. = 0.0 CU. YD.
 - 15 14' - STORM SEW CL A 2, 18" @ 1.00% T.B.F. = 0.0 CU. YD.
 - 16 35' - STORM SEW CL A 2, 15" @ 1.00% T.B.F. = 8.7 CU. YD.
 - 17 64' - STORM SEW WM REQ, 12" @ 1.00% T.B.F. = 11.1 CU. YD.
 - 18 195' - STORM SEW CL A 2, 24" @ 0.40% T.B.F. = 0.0 CU. YD.
 - 19 13' - STORM SEW CL A 2, 15" @ 1.00% T.B.F. = 0.0 CU. YD.
 - 20 31' - STORM SEW CL A 2, 12" @ 1.00% T.B.F. = 8.4 CU. YD.
 - 21 64' - STORM SEW WM REQ, 12" @ 1.00% T.B.F. = 12.5 CU. YD.
 - 22 8' - STORM SEW CL A 1, 12" @ 0.50% T.B.F. = 0.2 CU. YD.
 - 23 175' - STORM SEW CL A 2, 24" @ 0.34% T.B.F. = 0.0 CU. YD.
 - 24 46' - STORM SEW CL A 2, 12" @ 1.00% T.B.F. = 11.2 CU. YD.
 - 25 53' - STORM SEW WM REQ, 12" @ 1.00% T.B.F. = 12.1 CU. YD.
 - 26 12' - STORM SEW CL A 1, 12" @ 0.50% T.B.F. = 0.0 CU. YD.
 - 30 112' - STORM SEW WM REQ, 18" @ 0.50% T.B.F. = 13.7 CU. YD.
 - 31 36' - STORM SEW CL A 2, 12" @ 0.50% T.B.F. = 5.4 CU. YD.
 - 32 52' - STORM SEW CL A 2, 12" @ 0.50% T.B.F. = 6.8 CU. YD.
 - A 58' - PIPE UNDERDRAINS, 6"
 - B 60' - PIPE UNDERDRAINS, 6"
 - C 52' - PIPE UNDERDRAINS, 6"
 - D 69' - PIPE UNDERDRAINS, 6"
 - E 52' - PIPE UNDERDRAINS, 6"
 - F 65' - PIPE UNDERDRAINS, 6"
 - G 96' - PIPE UNDERDRAINS, 6"
 - H 46' - PIPE UNDERDRAINS, 6"
 - I 60' - PIPE UNDERDRAINS, 6"
 - J 94' - PIPE UNDERDRAINS, 6"

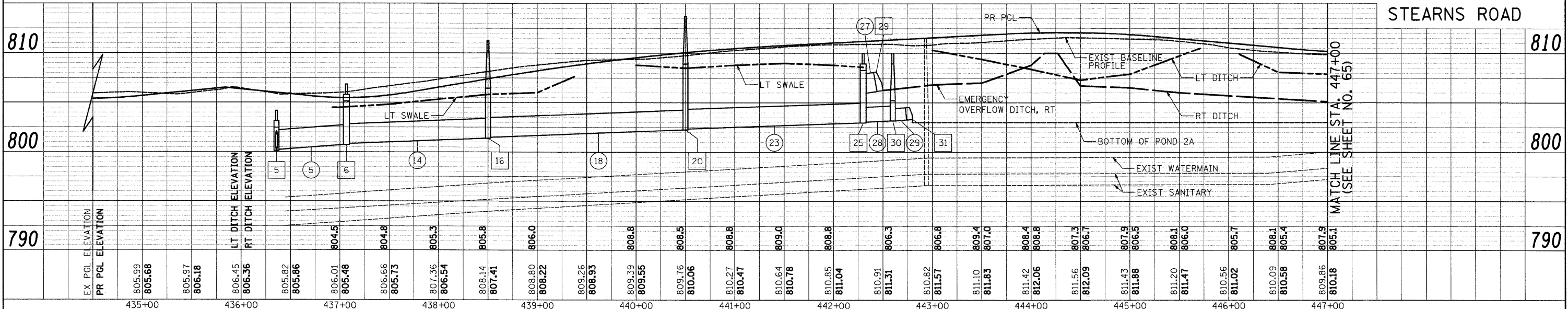

FILE NAME =	USER NAME = jsm	DESIGNED - MJP	REVISED -	KANE COUNTY DIVISION OF TRANSPORTATION	DRAINAGE AND UTILITIES - STEARNS ROAD	F.A. RTE. 361	SECTION 06-00214-25-BR	COUNTY KANE	TOTAL SHEETS 220	SHEET NO. 64	
PLOT SCALE = 50.0000' / IN.	CHECKED - DNM	REVISED -	REVISED -			SCALE: 1"=50'		SHEET NO. 2 OF 14 SHEETS		STA. 434+00 TO STA. 447+00	
PLOT DATE = 3/27/2009	DATE = 3/30/09	REVISED -	REVISED -			CONTRACT NO. 63076					
FED. ROAD DIST. NO. 1 [ILLINOIS] FED. AID PROJECT											

DATE	
BY	
REVISIONS	
NO.	
DESCRIPTION	
DATE	
BY	
REVISIONS	
NO.	
DESCRIPTION	
DATE	
BY	
REVISIONS	
NO.	
DESCRIPTION	

DATE	
BY	
REVISIONS	
NO.	
DESCRIPTION	
DATE	
BY	
REVISIONS	
NO.	
DESCRIPTION	
DATE	
BY	
REVISIONS	
NO.	
DESCRIPTION	

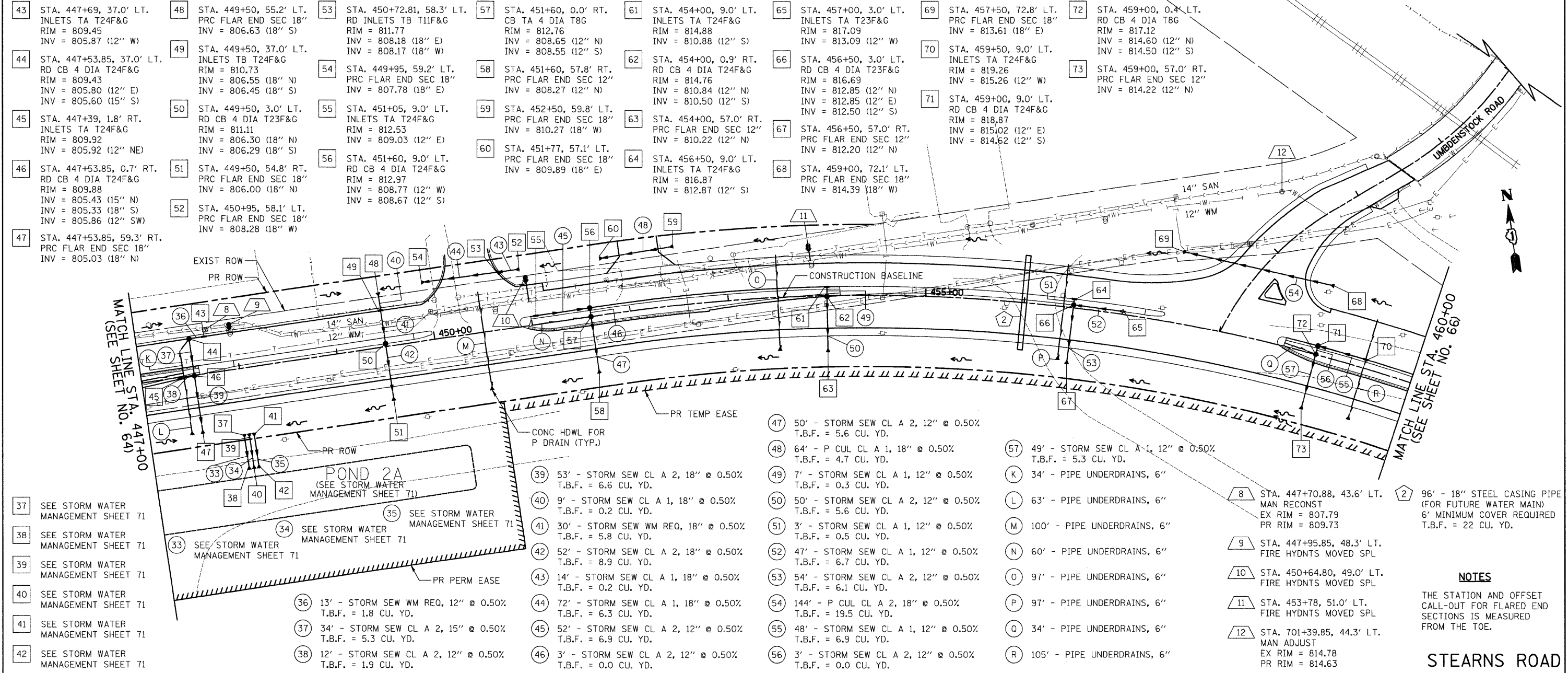

- 37 SEE STORM WATER MANAGEMENT SHEET 71
- 38 SEE STORM WATER MANAGEMENT SHEET 71
- 39 SEE STORM WATER MANAGEMENT SHEET 71
- 40 SEE STORM WATER MANAGEMENT SHEET 71
- 41 SEE STORM WATER MANAGEMENT SHEET 71
- 42 SEE STORM WATER MANAGEMENT SHEET 71



- 39 53' - STORM SEW CL A 2, 18" @ 0.50% T.B.F. = 6.6 CU. YD.
- 40 9' - STORM SEW CL A 1, 18" @ 0.50% T.B.F. = 0.2 CU. YD.
- 41 30' - STORM SEW WM REQ, 18" @ 0.50% T.B.F. = 5.8 CU. YD.
- 42 52' - STORM SEW CL A 2, 18" @ 0.50% T.B.F. = 8.9 CU. YD.
- 43 14' - STORM SEW CL A 1, 18" @ 0.50% T.B.F. = 0.2 CU. YD.
- 44 72' - STORM SEW CL A 1, 18" @ 0.50% T.B.F. = 6.3 CU. YD.
- 45 52' - STORM SEW CL A 2, 12" @ 0.50% T.B.F. = 6.9 CU. YD.
- 46 3' - STORM SEW CL A 2, 12" @ 0.50% T.B.F. = 0.0 CU. YD.
- 47 50' - STORM SEW CL A 2, 12" @ 0.50% T.B.F. = 5.6 CU. YD.
- 48 64' - P CUL CL A 1, 18" @ 0.50% T.B.F. = 4.7 CU. YD.
- 49 7' - STORM SEW CL A 1, 12" @ 0.50% T.B.F. = 0.3 CU. YD.
- 50 50' - STORM SEW CL A 2, 12" @ 0.50% T.B.F. = 5.6 CU. YD.
- 51 3' - STORM SEW CL A 1, 12" @ 0.50% T.B.F. = 0.5 CU. YD.
- 52 47' - STORM SEW CL A 1, 12" @ 0.50% T.B.F. = 6.7 CU. YD.
- 53 54' - STORM SEW CL A 2, 12" @ 0.50% T.B.F. = 6.1 CU. YD.
- 54 144' - P CUL CL A 2, 18" @ 0.50% T.B.F. = 19.5 CU. YD.
- 55 48' - STORM SEW CL A 1, 12" @ 0.50% T.B.F. = 6.9 CU. YD.
- 56 3' - STORM SEW CL A 2, 12" @ 0.50% T.B.F. = 0.0 CU. YD.
- 57 49' - STORM SEW CL A-1, 12" @ 0.50% T.B.F. = 5.3 CU. YD.
- K 34' - PIPE UNDERDRAINS, 6"
- L 63' - PIPE UNDERDRAINS, 6"
- M 100' - PIPE UNDERDRAINS, 6"
- N 60' - PIPE UNDERDRAINS, 6"
- O 97' - PIPE UNDERDRAINS, 6"
- P 97' - PIPE UNDERDRAINS, 6"
- Q 34' - PIPE UNDERDRAINS, 6"
- R 105' - PIPE UNDERDRAINS, 6"
- 8 STA. 447+70.88, 43.6' LT. MAN RECONST EX RIM = 807.79 PR RIM = 809.73
- 9 STA. 447+95.85, 48.3' LT. FIRE HYDNTS MOVED SPL
- 10 STA. 450+64.80, 49.0' LT. FIRE HYDNTS MOVED SPL
- 11 STA. 453+78, 51.0' LT. FIRE HYDNTS MOVED SPL
- 12 STA. 701+39.85, 44.3' LT. MAN ADJUST EX RIM = 814.78 PR RIM = 814.63
- 2 96' - 18" STEEL CASING PIPE (FOR FUTURE WATER MAIN) 6" MINIMUM COVER REQUIRED T.B.F. = 22 CU. YD.

NOTES
THE STATION AND OFFSET CALL-OUT FOR FLARED END SECTIONS IS MEASURED FROM THE TOE.

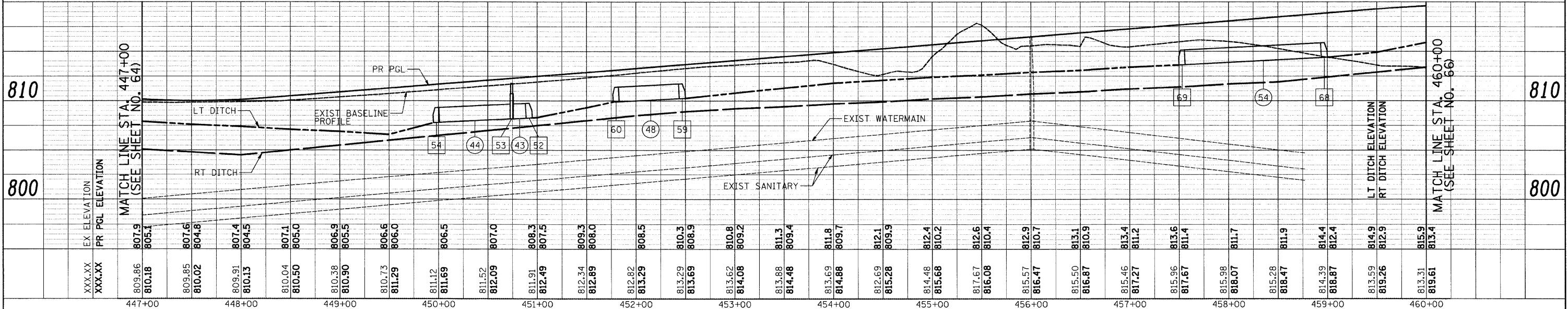

FILE NAME =	USER NAME = m_jp	DESIGNED - MJP	REVISED -	F.A. RTE. 361	SECTION 06-00214-25-BR	COUNTY KANE	TOTAL SHEETS 220	SHEET NO. 65
				KANE COUNTY DIVISION OF TRANSPORTATION		DRAINAGE AND UTILITIES - STEARNS ROAD		
PLOT SCALE = 50.0000' / IN. PLOT DATE = 3/27/2009				CHECKED - DNM DATE - 3/30/09		SCALE: 1"=50' SHEET NO. 3 OF 14 SHEETS STA. 447+00 TO STA. 460+00		
CONTRACT NO. 63076								FED. ROAD DIST. NO. 1 ILLINOIS FED. AID PROJECT

DATE	
BY	
REVISIONS	
1. PLOTTED	
2. ALIGNED	
3. CHECKED	
4. FILED	
NO.	

DATE	
BY	
REVISIONS	
1. GRADES CHECKED	
2. B.M. NOTED	
3. STRUCTURE NOTATIONS CHECKED	
NO.	

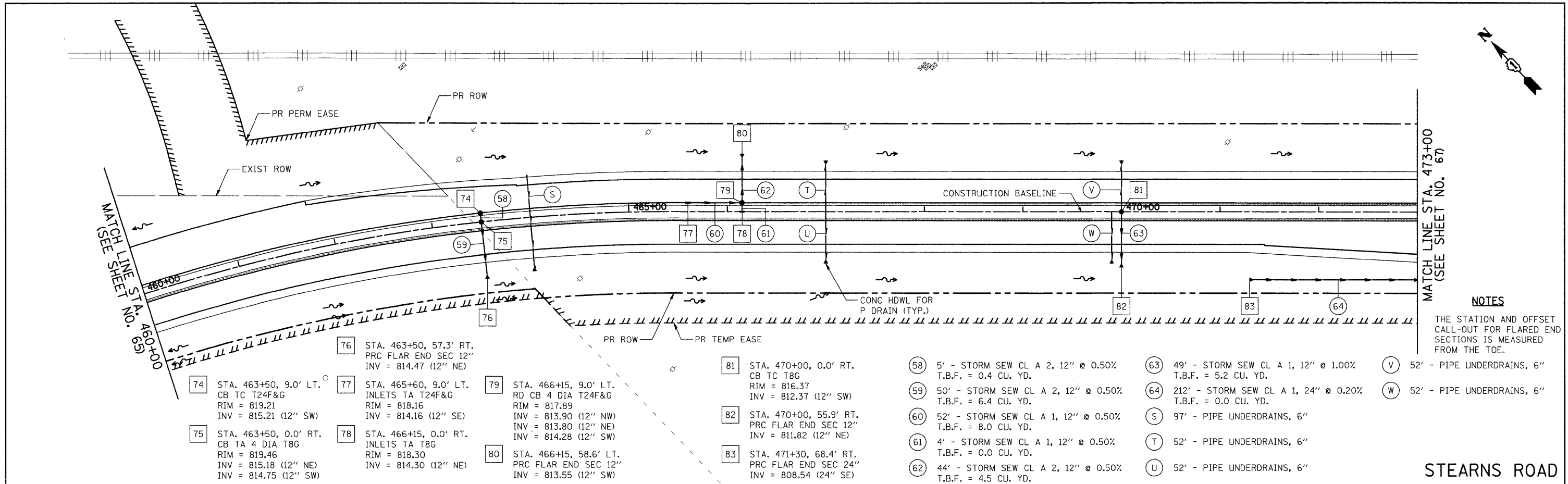

- 74 STA. 463+50, 9.0' LT. CB TC T24F&G RIM = 819.21 INV = 815.21 (12" SW)
- 75 STA. 463+50, 0.0' RT. CB TA 4 DIA T8G RIM = 819.46 INV = 815.18 (12" NE)
- 76 STA. 463+50, 57.3' RT. PRC FLAR END SEC 12" INV = 814.47 (12" NE)
- 77 STA. 465+60, 9.0' LT. INLETS TA T24F&G RIM = 818.16 INV = 814.16 (12" SE)
- 78 STA. 466+15, 0.0' RT. INLETS TA T8G RIM = 818.30 INV = 814.30 (12" NE)
- 79 STA. 466+15, 9.0' LT. RD CB 4 DIA T24F&G RIM = 817.89 INV = 813.90 (12" NW)
- 80 STA. 466+15, 58.6' LT. PRC FLAR END SEC 12" INV = 813.80 (12" NE)
- 81 STA. 470+00, 0.0' RT. CB TC T8G RIM = 816.37 INV = 812.37 (12" SW)
- 82 STA. 470+00, 55.9' RT. PRC FLAR END SEC 12" INV = 811.82 (12" NE)
- 83 STA. 471+30, 68.4' RT. PRC FLAR END SEC 24" INV = 808.54 (24" SE)
- 58 5' - STORM SEW CL A 2, 12" @ 0.50% T.B.F. = 0.4 CU. YD.
- 59 50' - STORM SEW CL A 2, 12" @ 0.50% T.B.F. = 6.4 CU. YD.
- 60 52' - STORM SEW CL A 1, 12" @ 0.50% T.B.F. = 8.0 CU. YD.
- 61 4' - STORM SEW CL A 1, 12" @ 0.50% T.B.F. = 0.0 CU. YD.
- 62 44' - STORM SEW CL A 2, 12" @ 0.50% T.B.F. = 4.5 CU. YD.
- 63 49' - STORM SEW CL A 1, 12" @ 1.00% T.B.F. = 5.2 CU. YD.
- 64 212' - STORM SEW CL A 1, 24" @ 0.20% T.B.F. = 0.0 CU. YD.
- V 52' - PIPE UNDERDRAINS, 6"
- W 52' - PIPE UNDERDRAINS, 6"
- S 97' - PIPE UNDERDRAINS, 6"
- T 52' - PIPE UNDERDRAINS, 6"
- U 52' - PIPE UNDERDRAINS, 6"

NOTES
THE STATION AND OFFSET CALL-OUT FOR FLARED END SECTIONS IS MEASURED FROM THE TOE.

STEARNS ROAD

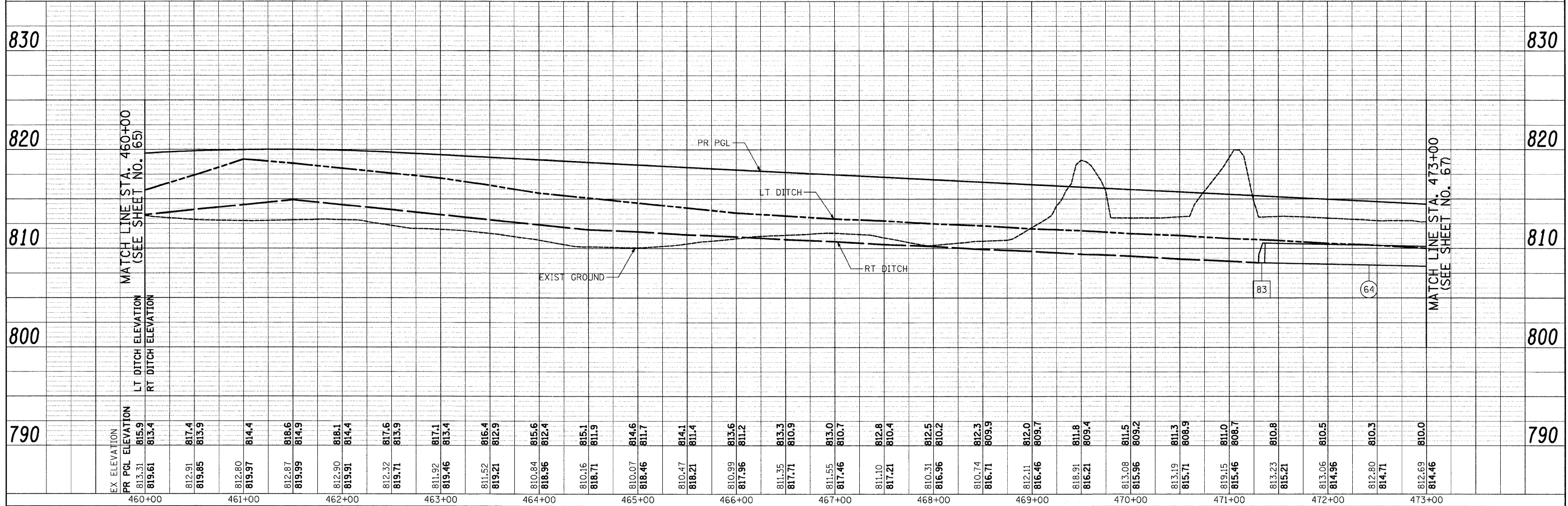

EX ELEVATION	PR PGL ELEVATION	LT DITCH ELEVATION	RT DITCH ELEVATION
813.31	815.9	813.4	813.4
819.61	817.4	813.9	813.9
812.80	814.4	814.4	814.4
812.87	818.6	814.9	814.9
819.99	818.1	814.4	814.4
812.32	817.6	813.9	813.9
819.71	817.1	813.4	813.4
811.92	816.4	812.9	812.9
819.46	815.6	812.4	812.4
811.52	815.1	811.9	811.9
819.21	814.6	811.7	811.7
810.84	814.1	811.4	811.4
818.96	813.6	811.2	811.2
810.16	813.3	810.9	810.9
818.71	813.0	810.7	810.7
810.07	812.8	810.4	810.4
818.46	812.5	810.2	810.2
810.47	812.3	809.9	809.9
818.21	812.0	809.7	809.7
810.99	811.8	809.4	809.4
817.96	811.5	809.2	809.2
811.35	811.3	808.9	808.9
817.71	811.0	808.7	808.7
811.55	810.8	810.8	810.8
817.46	810.5	810.5	810.5
811.10	810.3	810.3	810.3
817.21	810.0	810.0	810.0
810.31	814.46	814.46	814.46
816.96			
810.74			
816.71			
812.11			
816.46			
818.91			
816.21			
813.08			
815.96			
813.19			
815.71			
819.15			
815.46			
813.23			
815.21			
813.06			
814.96			
812.80			
814.71			
812.69			
814.46			



FILE NAME =	USER NAME = mjp	DESIGNED - MJP	REVISED -
		DRAWN - MJP	REVISED -
		CHECKED - DNM	REVISED -
		DATE - 3/30/09	REVISED -

**KANE COUNTY
DIVISION OF TRANSPORTATION**

DRAINAGE AND UTILITIES - STEARNS ROAD

SCALE: 1"=50' SHEET NO. 4 OF 14 SHEETS STA. 460+00 TO STA. 473+00

F.A. RTE.	SECTION	COUNTY	TOTAL SHEETS	SHEET NO.
361	06-00214-25-BR	KANE	220	66
CONTRACT NO. 63076				
FED. ROAD DIST. NO. 1 ILLINOIS FED. AID PROJECT				

- 84 STA. 474+50, 0.0' RT. INLETS TA T8G RIM = 813.77 INV = 809.77 (12" NW)
- 85 STA. 473+50, 0.0' RT. CB TA 4 DIA T8G RIM = 814.62 INV = 809.28 (12" SE) INV = 809.18 (12" SW)
- 86 STA. 473+50, 68.4' RT. RD MAN 5 DIA T8G RIM = 812.12 INV = 808.10 (24" NW) INV = 808.10 (24" SE) INV = 808.86 (12" NE)
- 87 STA. 475+00, 68.4' RT. RD MAN 5 DIA T8G RIM = 811.37 INV = 807.81 (24" NW) INV = 807.80 (24" SE)
- 88 STA. 476+00, 62.8' RT. PRC FLAR END SEC 24" INV = 807.60 (24" NW)
- 89 STA. 477+50, 3.0' RT. CB TC T23F&G RIM = 812.21 INV = 808.21 (12" SW)
- 90 STA. 477+50, 56.4' RT. PRC FLAR END SEC 12" INV = 807.95 (12" NE)

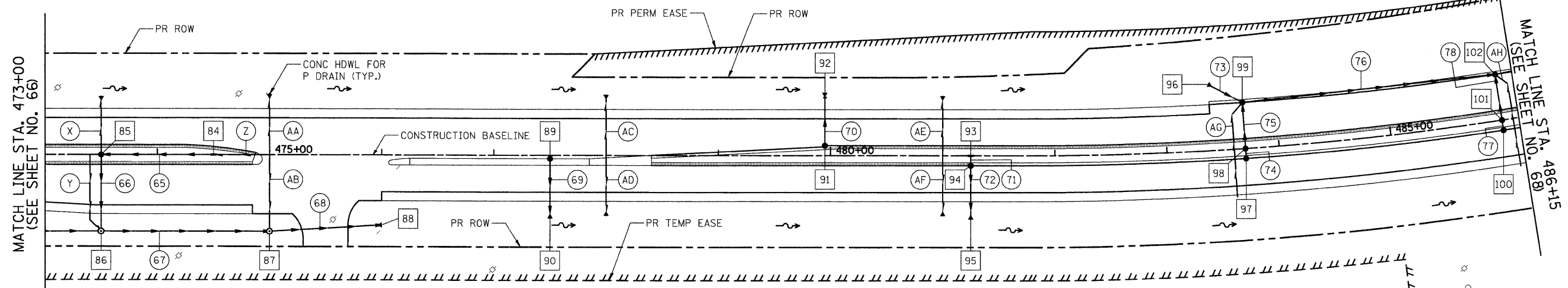

- 91 STA. 479+95, 9.0' LT. CB TC T24F&G RIM = 810.99 INV = 806.99 (12" NE)
- 92 STA. 479+95, 56.1' LT. PRC FLAR END SEC 12" INV = 806.75 (12" SW)
- 93 STA. 481+25, 0.0' RT. INLETS TA T8G RIM = 810.66 INV = 806.66 (12" SW)
- 94 STA. 481+25, 9.0' RT. RD CB 4 DIA T24F&G RIM = 810.34 INV = 806.64 (12" NE) INV = 806.54 (12" SW)
- 95 STA. 481+25, 57.0' RT. PRC FLAR END SEC 12" INV = 806.30 (12" NE)
- 96 STA. 483+40, 59.0' LT. PRC FLAR END SEC 24" INV = 804.54 (24" S)
- 97 STA. 483+70, 9.0' RT. CB TC T24F&G RIM = 809.11 INV = 805.11 (12" NE)
- 98 STA. 483+70, 0.0' RT. CB TA 4 DIA T8G RIM = 809.36 INV = 805.01 (12" SW) INV = 804.91 (12" NE)
- 99 STA. 483+70, 41.0' LT. RD CB 5 DIA T24F&G RIM = 808.19 INV = 804.14 (24" N) INV = 803.64 (24" SE) INV = 803.97 (12" SW)
- 100 STA. 486+00, 9.0' RT. CB TC T24F&G RIM = 807.61 INV = 803.61 (12" NE)
- 101 STA. 486+00, 0.0' RT. CB TA 4 DIA T8G RIM = 807.86 INV = 803.51 (12" SW) INV = 803.41 (12" NE)
- 102 STA. 486+00, 41.0' LT. RD CB 5 DIA T24F&G RIM = 806.69 INV = 800.09 (24" NW) INV = 799.59 (24" SE) INV = 802.47 (12" SW)
- 65 97' - STORM SEW CL A 2, 12" @ 0.50% T.B.F. = 0.0 CU. YD.
- 66 64' - STORM SEW CL A 2, 12" @ 0.50% T.B.F. = 9.1 CU. YD.
- 67 145' - STORM SEW CL A 1, 24" @ 0.20% T.B.F. = 0.0 CU. YD.
- 68 92' - STORM SEW CL A 2, 24" @ 0.20% T.B.F. = 10.9 CU. YD.
- 69 46' - STORM SEW CL A 1, 12" @ 0.50% T.B.F. = 5.1 CU. YD.
- 70 41' - STORM SEW CL A 1, 12" @ 0.50% T.B.F. = 4.5 CU. YD.
- 71 4' - STORM SEW CL A 1, 12" @ 0.50% T.B.F. = 0.0 CU. YD.
- 72 42' - STORM SEW CL A 1, 12" @ 0.50% T.B.F. = 4.5 CU. YD.
- 73 26' - STORM SEW CL A 1, 24" @ 1.25% T.B.F. = 0.6 CU. YD.
- 74 5' - STORM SEW CL A 2, 12" @ 2.00% T.B.F. = 0.4 CU. YD.
- 75 38' - STORM SEW CL A 2, 12" @ 2.50% T.B.F. = 6.5 CU. YD.
- 76 222' - STORM SEW CL A 2, 24" @ 1.60% T.B.F. = 68.5 CU. YD.
- 77 5' - STORM SEW CL A 2, 12" @ 2.00% T.B.F. = 0.4 CU. YD.
- 78 38' - STORM SEW CL A 2, 12" @ 2.50% T.B.F. = 6.5 CU. YD.
- X 52' - PIPE UNDERDRAINS, 6"
- Y 69' - PIPE UNDERDRAINS, 6"
- Z 50' - PIPE UNDERDRAINS, 6"
- AA 54' - PIPE UNDERDRAINS, 6"
- AB 69' - PIPE UNDERDRAINS, 6"
- AC 57' - PIPE UNDERDRAINS, 6"
- AD 52' - PIPE UNDERDRAINS, 6"
- AE 53' - PIPE UNDERDRAINS, 6"
- AF 54' - PIPE UNDERDRAINS, 6"
- AG 84' - PIPE UNDERDRAINS, 6"
- AH 84' - PIPE UNDERDRAINS, 6"

NOTES
THE STATION AND OFFSET CALL-OUT FOR FLARED END SECTIONS IS MEASURED FROM THE TOE.

STEARNS ROAD

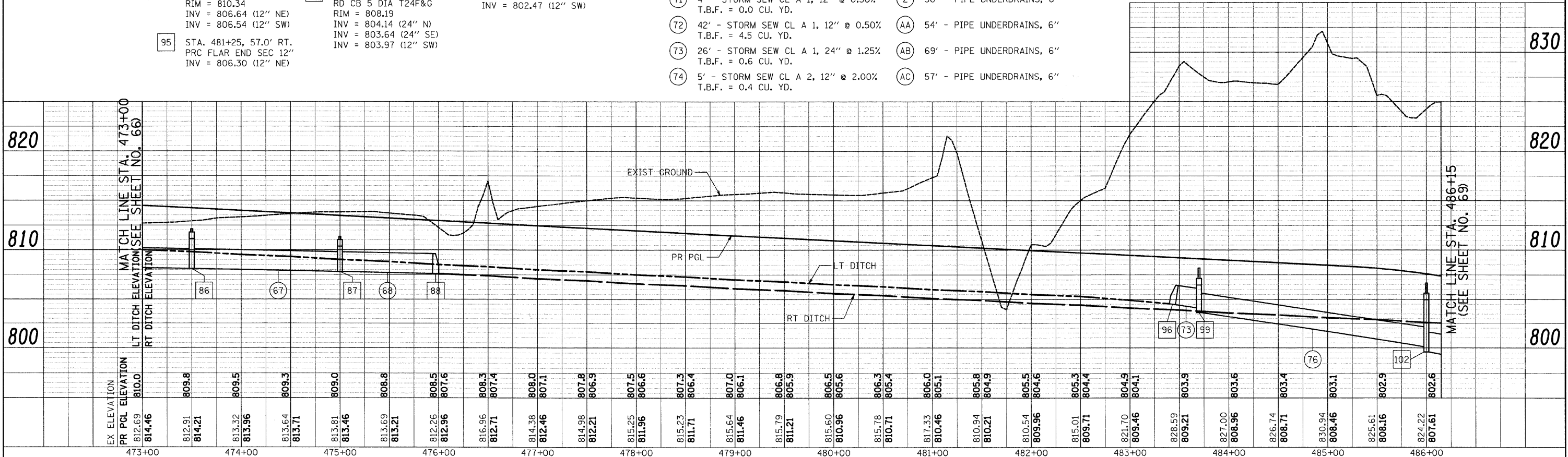

EX ELEVATION	PR PGL ELEVATION	LT DITCH ELEVATION	RT DITCH ELEVATION
812.69	814.46		
809.8	814.21		
809.5	813.96		
809.3	813.71		
809.0	813.46		
808.8	813.21		
808.5	812.96		
808.3	812.71		
808.0	812.46		
807.8	812.21		
807.5	811.96		
807.3	811.71		
807.0	811.46		
806.8	811.21		
806.5	810.96		
806.3	810.71		
806.0	810.46		
805.8	810.21		
805.5	809.96		
805.3	809.71		
805.0	809.46		
805.8	809.21		
805.6	808.96		
805.4	808.71		
805.1	808.46		
805.8	808.21		
805.5	807.96		
805.3	807.71		
805.0	807.46		
804.9	807.21		
804.6	806.96		
804.4	806.71		
804.1	806.46		
803.9	806.21		
803.6	805.96		
803.4	805.71		
803.1	805.46		
802.9	805.21		
802.6	804.96		

DATE	
BY	
REVIEWED	
DESIGNED	
DRAWN	
CHECKED	
DATE	

DATE	
BY	
REVIEWED	
DESIGNED	
DRAWN	
CHECKED	
DATE	



FILE NAME =
USER NAME = mjp
DESIGNED - MJP
DRAWN - MJP
CHECKED - DNM
DATE - 3/30/09

REVISED -
REVISED -
REVISED -
REVISED -

KANE COUNTY
DIVISION OF TRANSPORTATION

DRAINAGE AND UTILITIES - STEARNS ROAD
SCALE: 1"=50'
SHEET NO. 5 OF 14 SHEETS
STA. 473+00 TO STA. 486+00

F.A. RTE. 361
SECTION 06-00214-25-BR
COUNTY KANE
TOTAL SHEETS 220
SHEET NO. 67
CONTRACT NO. 63076
FED. ROAD DIST. NO. 1 ILLINOIS FED. AID PROJECT



- | | | | | |
|---|--|--|---|---|
| 103 STA. 488+50, 9.0' RT.
CB TC T24F&G
RIM = 800.75
INV = 796.75 (12" NE) | 107 STA. 491+00, 9.0' RT.
CB TC T24F&G
RIM = 791.23
INV = 787.48 (12" N) | 111 STA. 493+50, 0.0' RT.
CB TA 4 DIA T8G
RIM = 781.96
INV = 777.91 (12" S) | 115 STA. 496+00, 56.0' LT.
PRC FLAR END SEC 12"
INV = 767.75 (12" S) | 119 STA. 498+50, 60.0' RT.
RD MAN 5 DIA T1F CL
RIM = 764.24
INV = 759.78 (24" W) |
| 104 STA. 488+50, 0.0' RT.
CB TA 4 DIA T8G
RIM = 801.01
INV = 796.65 (12" SW) | 108 STA. 491+00, 0.0' RT.
CB TA 4 DIA T8G
RIM = 791.48
INV = 787.43 (12" S) | 112 STA. 493+50, 56.0' LT.
PRC FLAR END SEC 12"
INV = 777.27 (12" S) | 116 STA. 497+50, 66.5' RT.
PRC FLAR END SEC 24"
INV = 761.53 (24" E) | INV = 749.25 (30" E) |
| 105 STA. 488+50, 41.0' LT.
RD CB 5 DIA T24F&G
RIM = 799.83
INV = 795.35 (24" NW) | 109 STA. 491+00, 56.0' LT.
PRC FLAR END SEC 12"
INV = 786.79 (12" S) | 113 STA. 496+00, 9.0' RT.
CB TC T24F&G
RIM = 772.19
INV = 768.44 (12" N) | 117 STA. 498+50, 0.0' RT.
INLETS TA T8G
RIM = 762.92
INV = 758.92 (12" S) | INV = 758.29 (12" N) |
| 106 STA. 489+10, 59.0' LT.
PRC FLAR END SEC 24"
INV = 793.82 (24" W) | 110 STA. 493+50, 9.0' RT.
CB TC T24F&G
RIM = 781.71
INV = 777.96 (12" N) | 114 STA. 496+00, 0.0' RT.
CB TA 4 DIA T8G
RIM = 772.44
INV = 768.39 (12" S) | 118 STA. 498+50, 9.0' RT.
RD CB 4 DIA T24F&G
RIM = 762.66
INV = 758.88 (12" N) | |

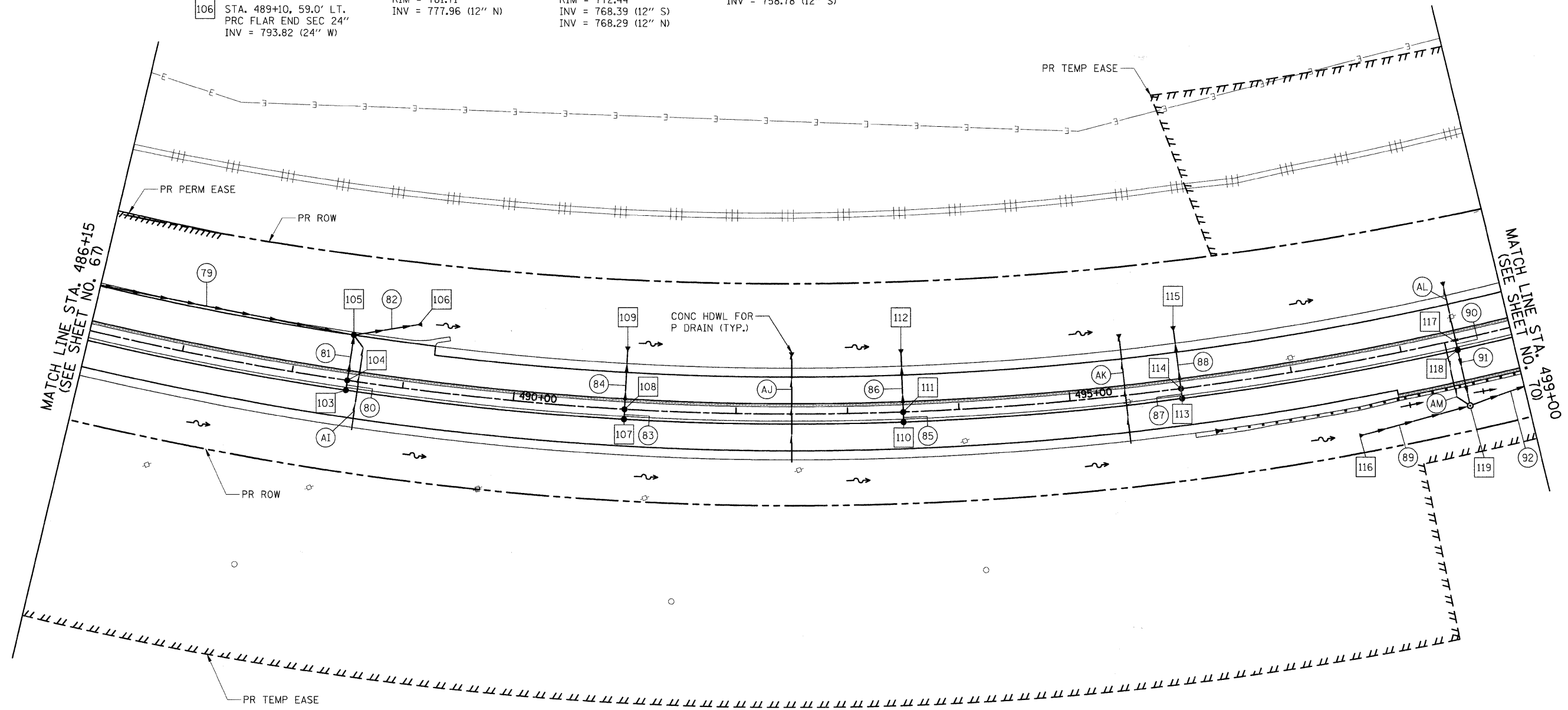

- | | | | |
|--|--|---|-------------------------------|
| 79 242' - STORM SEW CL A 2, 24" @ 1.75%
T.B.F. = 85.5 CU. YD. | 84 48' - STORM SEW CL A 2, 12" @ 1.00%
T.B.F. = 5.2 CU. YD. | 89 94' - STORM SEW CL A 2, 24" @ 1.75%
T.B.F. = 0.0 CU. YD. | AI 84' - PIPE UNDERDRAINS, 6" |
| 80 5' - STORM SEW CL A 2, 12" @ 2.00%
T.B.F. = 0.4 CU. YD. | 85 5' - STORM SEW CL A 2, 12" @ 1.00%
T.B.F. = 0.3 CU. YD. | 90 4' - STORM SEW CL A 1, 12" @ 1.00%
T.B.F. = 0.0 CU. YD. | AU 98' - PIPE UNDERDRAINS, 6" |
| 81 38' - STORM SEW CL A 2, 12" @ 2.50%
T.B.F. = 6.5 CU. YD. | 86 48' - STORM SEW CL A 2, 12" @ 1.00%
T.B.F. = 5.2 CU. YD. | 91 49' - STORM SEW CL A 2, 12" @ 1.00%
T.B.F. = 9.3 CU. YD. | AK 98' - PIPE UNDERDRAINS, 6" |
| 82 53' - STORM SEW CL A 2, 24" @ 1.75%
T.B.F. = 2.2 CU. YD. | 87 5' - STORM SEW CL A 2, 12" @ 1.00%
T.B.F. = 0.3 CU. YD. | 92 251' - STORM SEW CL A 3, 30" @ 1.00%
T.B.F. = 112.3 CU. YD. | AL 53' - PIPE UNDERDRAINS, 6" |
| 83 5' - STORM SEW CL A 2, 12" @ 1.00%
T.B.F. = 0.3 CU. YD. | 88 48' - STORM SEW CL A 2, 12" @ 1.00%
T.B.F. = 5.2 CU. YD. | | AM 60' - PIPE UNDERDRAINS, 6" |

NOTES
THE STATION AND OFFSET CALL-OUT FOR FLARED END SECTIONS IS MEASURED FROM THE TOE.

STEARNS ROAD

FILE NAME =	USER NAME = m.jp	DESIGNED - MJP	REVISED -	KANE COUNTY DIVISION OF TRANSPORTATION	DRAINAGE AND UTILITIES - STEARNS ROAD	F.A. RTE. = 361	SECTION = 06-00214-25-BR	COUNTY = KANE	TOTAL SHEETS = 220	SHEET NO. = 68	
	PLOT SCALE = 50,0000' / IN.	DRAWN - MJP	REVISED -			SCALE: 1"=50' SHEET NO. 6 OF 14 SHEETS STA. 486+00 TO STA. 499+00					
	PLOT DATE = 3/27/2009	CHECKED - DNM	REVISED -			CONTRACT NO. 63076					
		DATE = 3/30/09	REVISED -			FED. ROAD DIST. NO. 1 (ILLINOIS) FED. AID PROJECT					

- 29 STA. 442+50, 65.5' RT.
PRC FLAR END SEC 24"
INV = 806.25 (24" W)
- 30 STA. 442+60, 90.0' RT.
RD MAN 6 DIA T1F CL
RESTRICTOR PLATE
RIM 1 = 810.00
RIM 2 = 810.00
INV = 803.18 (18" NW)
INV = 803.18 (15" SE)
- 31 STA. 442+80, 111.1' RT.
PRC FLAR END SEC 15"
INV = 803.33 (15" NW)

- 37 STA. 447+95, 66.4' RT.
PRC FLAR END SEC 18"
INV = 804.50 (18" S)
- 38 STA. 447+95, 101.9' RT.
PRC FLAR END SEC 18"
INV = 803.49 (18" N)
- 39 STA. 448+00, 66.4' RT.
PRC FLAR END SEC 18"
INV = 804.50 (18" S)

- 40 STA. 448+00, 101.9' RT.
PRC FLAR END SEC 18"
INV = 803.49 (18" N)
- 41 STA. 448+05, 66.4' RT.
PRC FLAR END SEC 18"
INV = 804.50 (18" S)
- 42 STA. 448+05, 101.9' RT.
PRC FLAR END SEC 18"
INV = 803.49 (18" N)

POND 2A DATA

NORMAL WATER ELEVATION = 803.33
 100 YEAR HIGH WATER ELEVATION = 806.50
 EMERGENCY OVERFLOW ELEVATION = 808.00
 100 YEAR RELEASE RATE = 0.76 CFS
 MAXIMUM ALLOWABLE RELEASE RATE = 0.91 CFS
 100 YEAR VOLUME REQUIRED = 3.47 AC-FT
 MAXIMUM STORAGE OF POND = 6.46 AC-FT

- 27 13' - STORM SEW CL A 1, 24" @ 1.50%
T.B.F. = 0.0 CU. YD.
- 28 39' - STORM SEW CL A 2, 18" @ 0.30%
T.B.F. = 0.0 CU. YD.
- 29 21' - STORM SEW CL A 2, 15" @ 0.50%
T.B.F. = 0.0 CU. YD.

- 33 24' - P CUL CL A 2, 18" @ 2.00%
T.B.F. = 0.0 CU. YD.
- 34 24' - P CUL CL A 2, 18" @ 2.00%
T.B.F. = 0.0 CU. YD.
- 35 24' - P CUL CL A 2, 18" @ 2.00%
T.B.F. = 0.0 CU. YD.

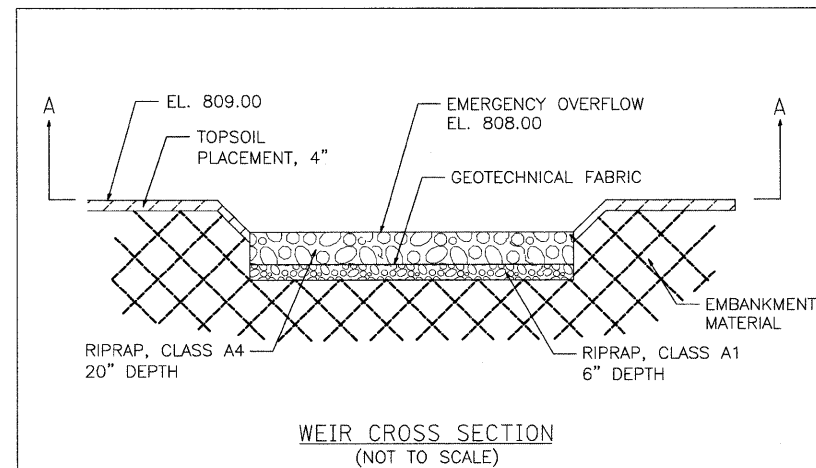
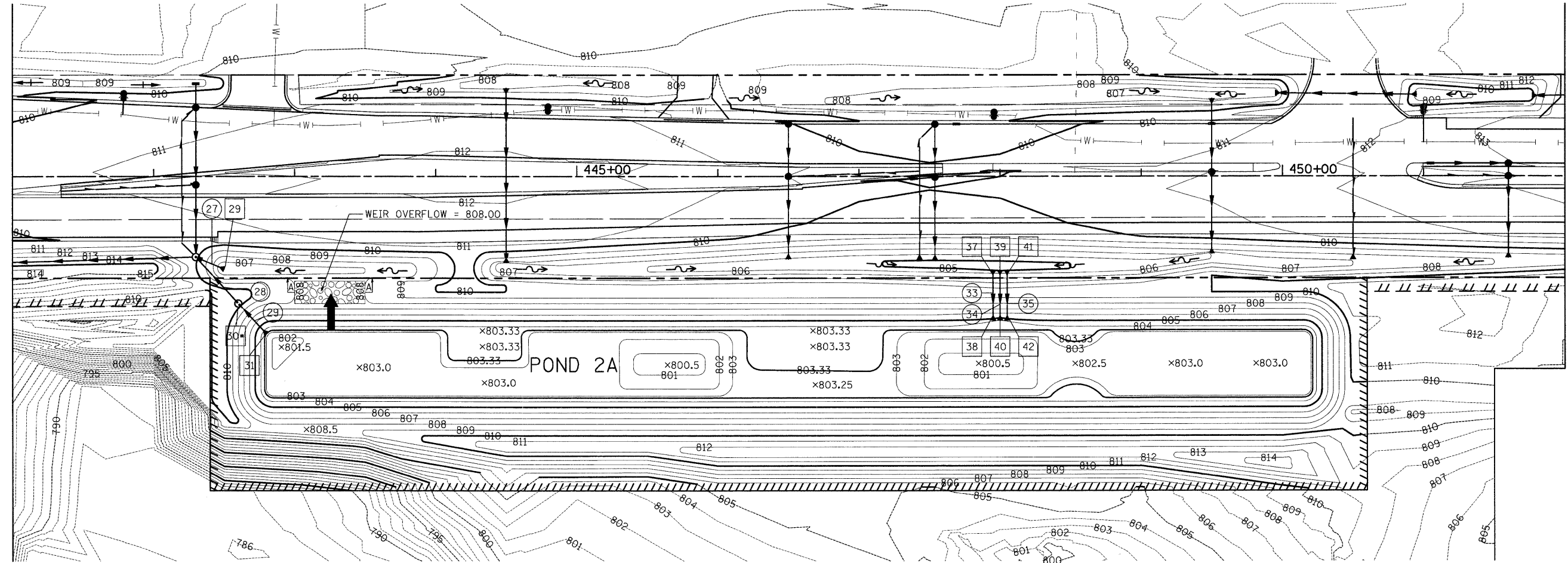

NOTES

- *FOR STRUCTURE 30, SEE MANHOLE WITH RESTRICTOR PLATE DETAIL ON SHEET 72.
- EMBANKMENT MATERIAL USED FOR THE CONSTRUCTION OF POND 2A SHALL BE CLAY MATERIAL ONLY AS APPROVED BY THE ENGINEER TO PREVENT EXCESSIVE PERMEATION OF WATER.

FILE NAME =	USER NAME = eds	DESIGNED - MJP	REVISED -	KANE COUNTY	STORM WATER MANAGEMENT - STEARNS ROAD	F.A. RTE. 361	SECTION 06-00214-25-BR	COUNTY KANE	TOTAL SHEETS 220	SHEET NO. 71
		DRAWN - MJP	REVISED -	DIVISION OF TRANSPORTATION	SCALE: 1" = 40'					
		CHECKED - DNM	REVISED -		SHEET NO. 9 OF 14 SHEETS					
		DATE - 3/30/09	REVISED -		STA. 441+00 TO STA. 452+00					
										CONTRACT NO. 63076
										ILLINOIS FED. AID PROJECT

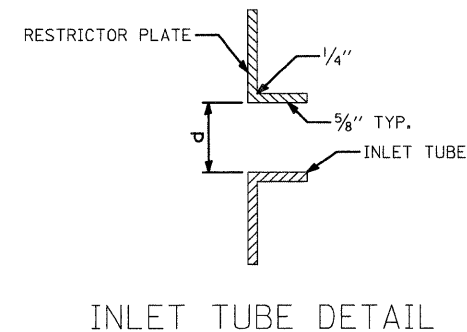
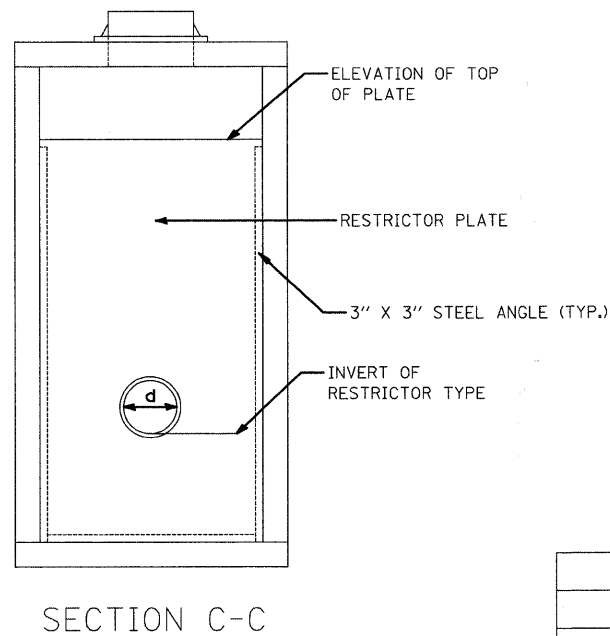
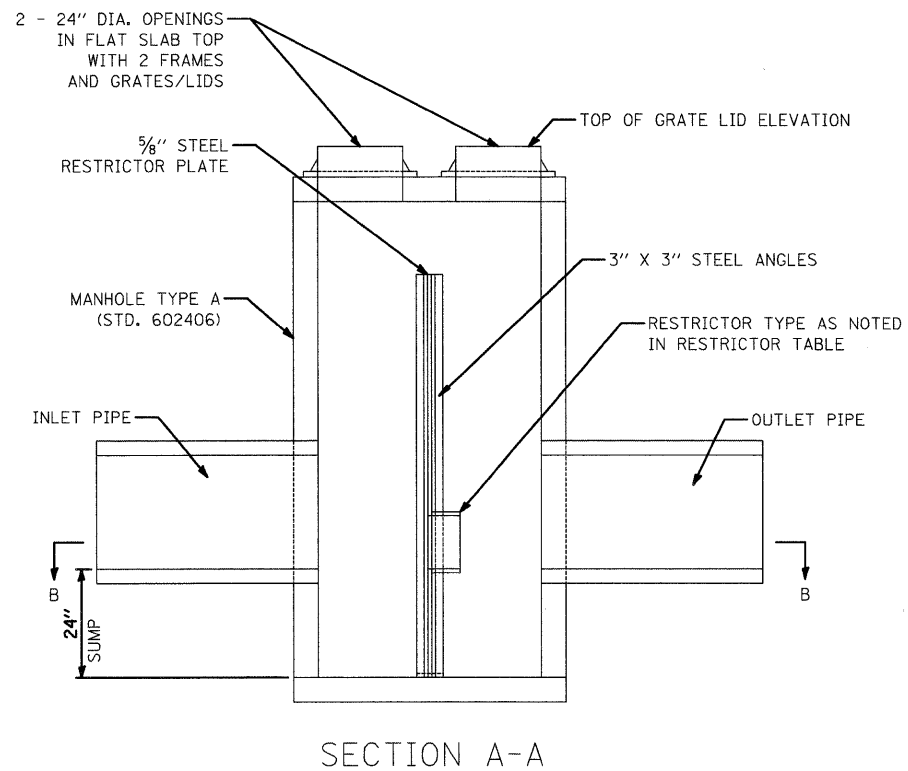
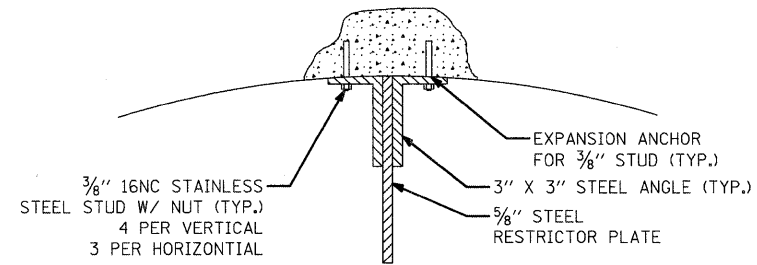
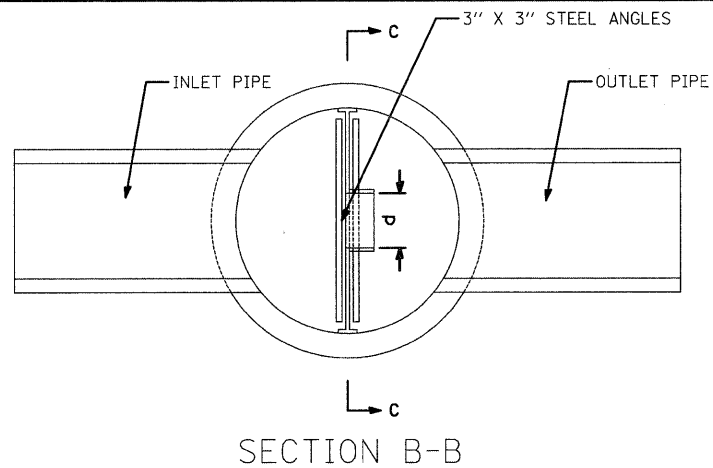
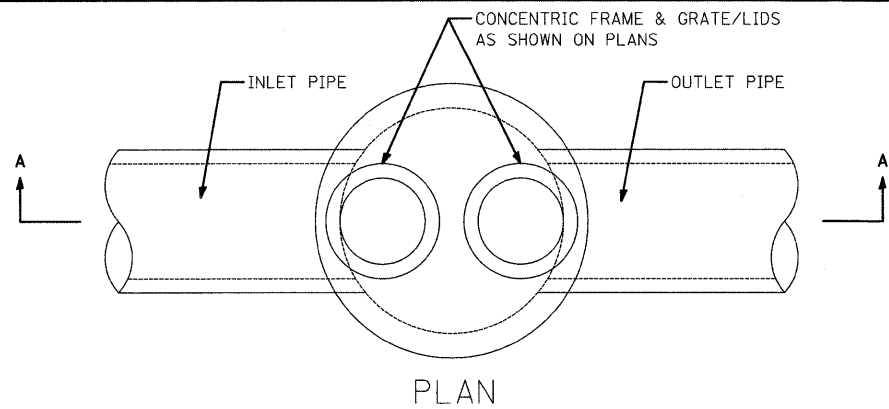

RESTRICTOR TYPE					
1	2	3	4	5	6
RE-ENRANT TUBE	SHARP EDGED	SQUARE EDGED	RE-ENRANT TUBE	SQUARE EDGED	ROUNDED
LENGTH: 1/2 TO 1 DIA.		STREAM CLEARS SIDES	LENGTH: 2-1/2 DIA.	LENGTH: 2-1/2 DIA.	
C=.52	C=.61	C=.61	C=.73	C=.82	C=.98

VALUES OF "C" FOR CIRCULAR AND SQUARE ORIFICES

NOTE:

1. ALL STEEL ANGLES AND PLATES TO BE GALVANIZED AFTER FABRICATION

2. ALL RESTRICTOR PLATES, ANGLES AND HARDWARE TO BE INCLUDED IN THE COST OF THE MANHOLE

3. BASIS OF PAYMENT: "MANHOLES, TYPE A, 6 FT. DIAMETER, TYPE 1 FRAME, CLOSED LID, RESTRICTOR PLATE" PER EACH

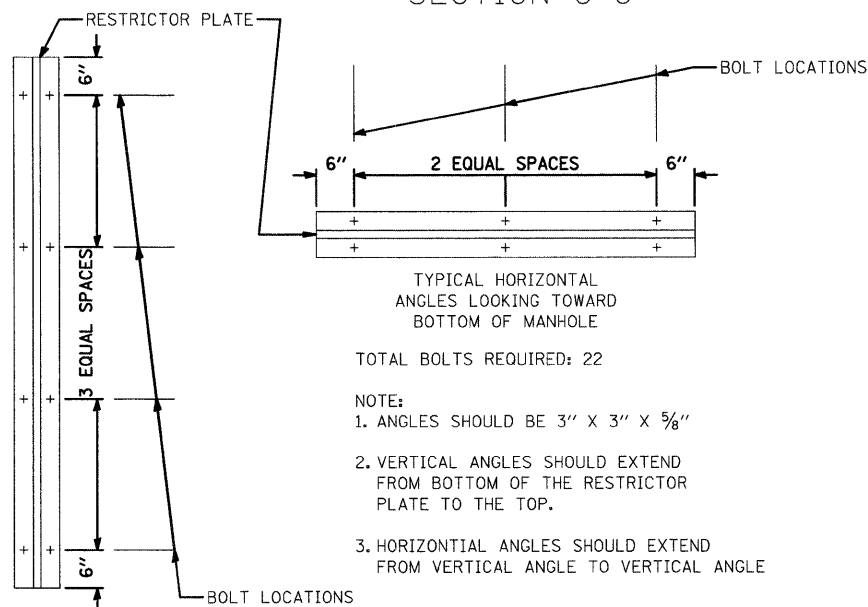

STATION	MANHOLE DIAMETER	FRAME AND GRATE	RESTRICTOR TYPE	INSIDE RESTRICTOR TYPE DIAMETER IN. (d)	INVERT OF RESTRICTOR TYPE	ELEVATION OF TOP OF PLATE OVERFLOW
442+60 RT	6'	2 - TIF CL	3	4	803.18	806.50

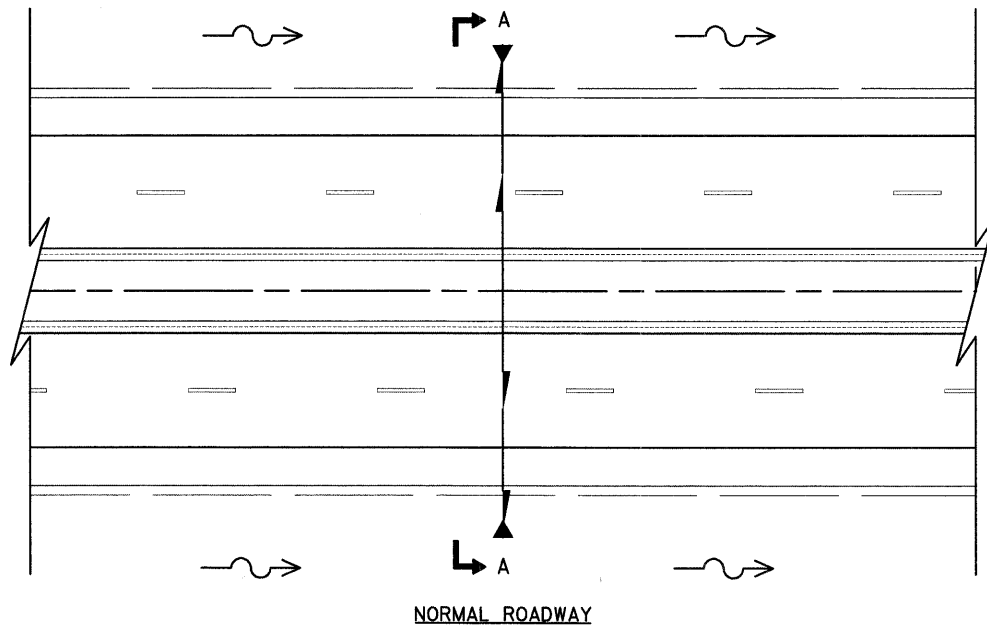

NORMAL ROADWAY

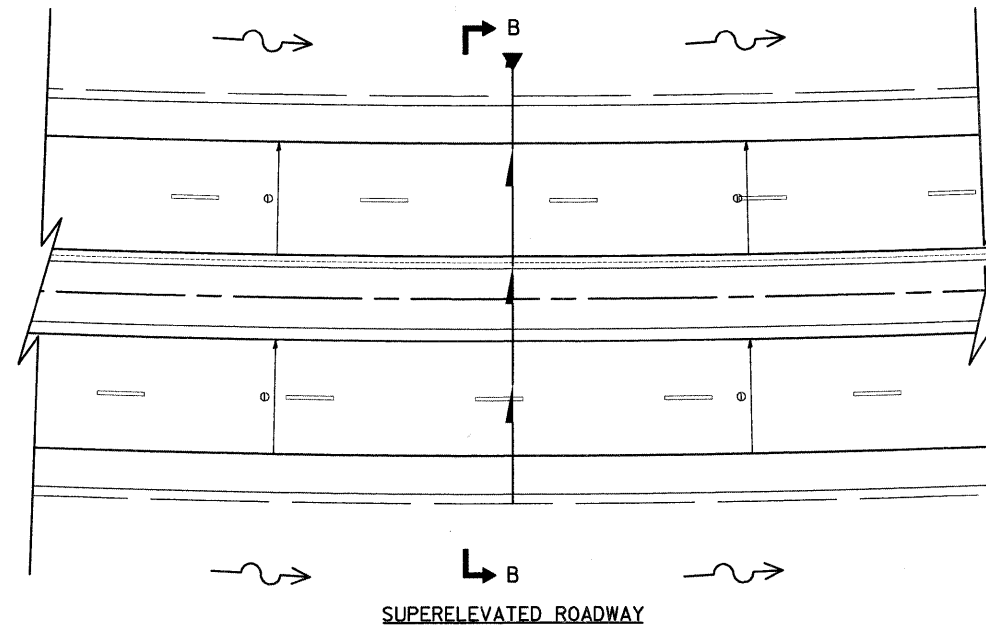

SUPERELEVATED ROADWAY

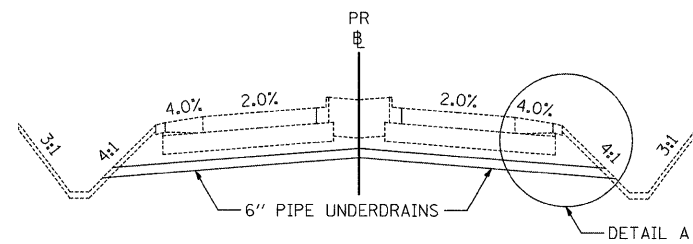

SECTION A-A

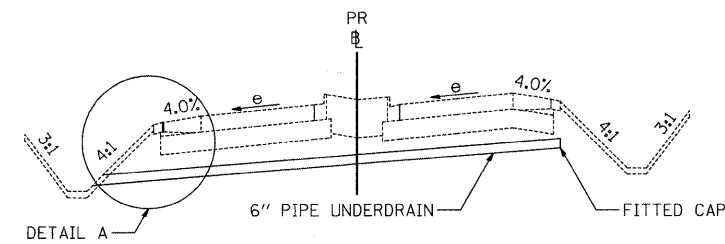

SECTION B-B

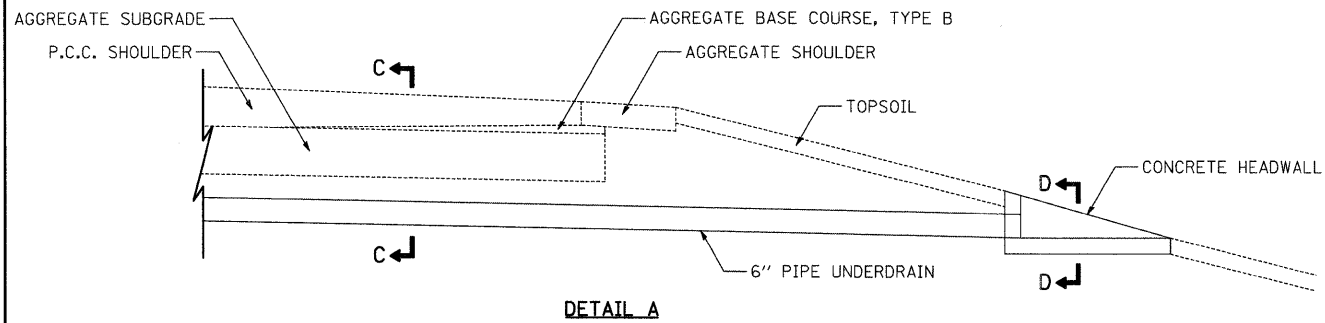

DETAIL A

WIDTH MIN. = O.D. + 4
WIDTH MAX. = 12

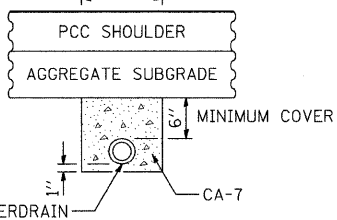

SECTION C-C

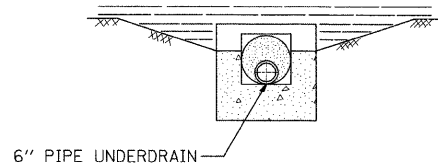

SECTION D-D

GENERAL NOTES

SEE STANDARD 601101 FOR DETAILS OF CONCRETE HEADWALL.
SEE STANDARD 483001 FOR DETAILS OF SHOULDERS NOT SHOWN.
TRENCH SHALL EXTEND 12" BEYOND UPGRADE END OF PIPE.

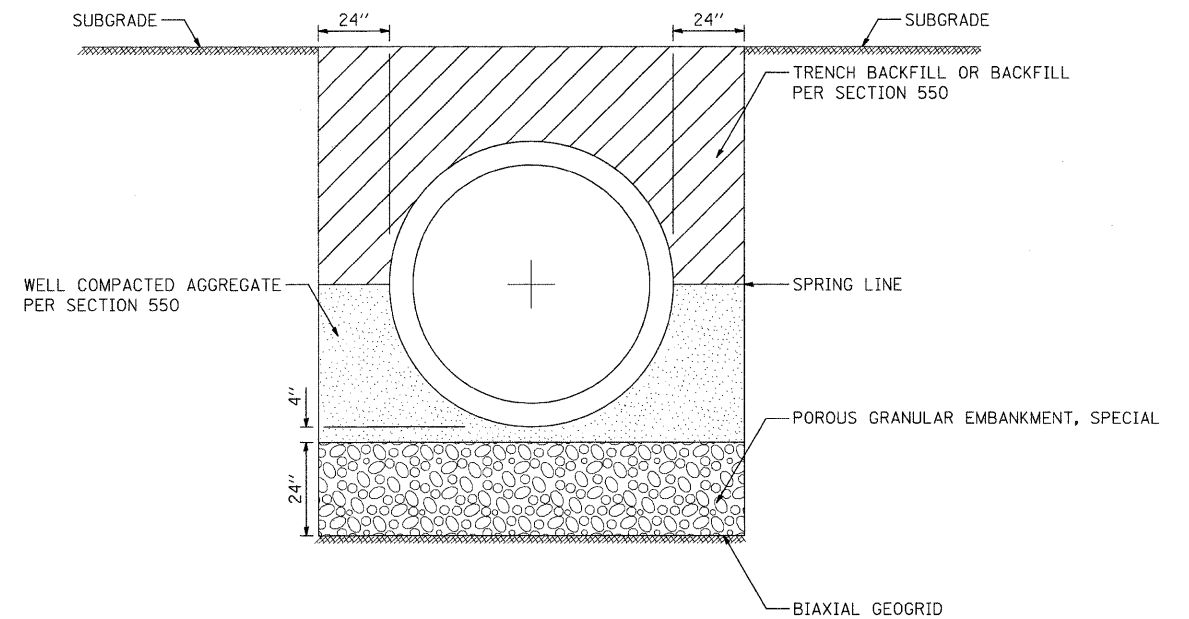

60" R.C.P. STORM SEWER UNDERCUT DETAIL - PIPE 113 & 114

	USER NAME = mjp	DESIGNED - MJP	REVISED -	<p align="center">KANE COUNTY DIVISION OF TRANSPORTATION</p>	<p align="center">DRAINAGE AND UTILITIES - STEARNS ROAD DRAINAGE DETAILS</p>		F.A. RTE. = 361	SECTION = 06-00214-25-BR	COUNTY = KANE	TOTAL SHEETS = 220	SHEET NO. = 73
	PLOT SCALE = 20,0000' / IN.	CHECKED - DNM	REVISED -		SCALE: N.T.S.	SHEET NO. 11 OF 14 SHEETS	STA. TO STA.	<p align="center">CONTRACT NO. 63076</p>			
	PLOT DATE = 3/27/2009	DATE = 3/30/09	REVISED -				<p align="center">FED. ROAD DIST. NO. 1 [ILLINOIS] FED. AID PROJECT</p>				

ROUTE NO.	SECTION	COUNTY	TOTAL SHEETS	SHEET NO.
F.A.P. 361	06-00214-25-BR	KANE	220	74
FED. ROAD DIST. NO. 1		ILLINOIS	FED. AID PROJECT-	

Contract #63076

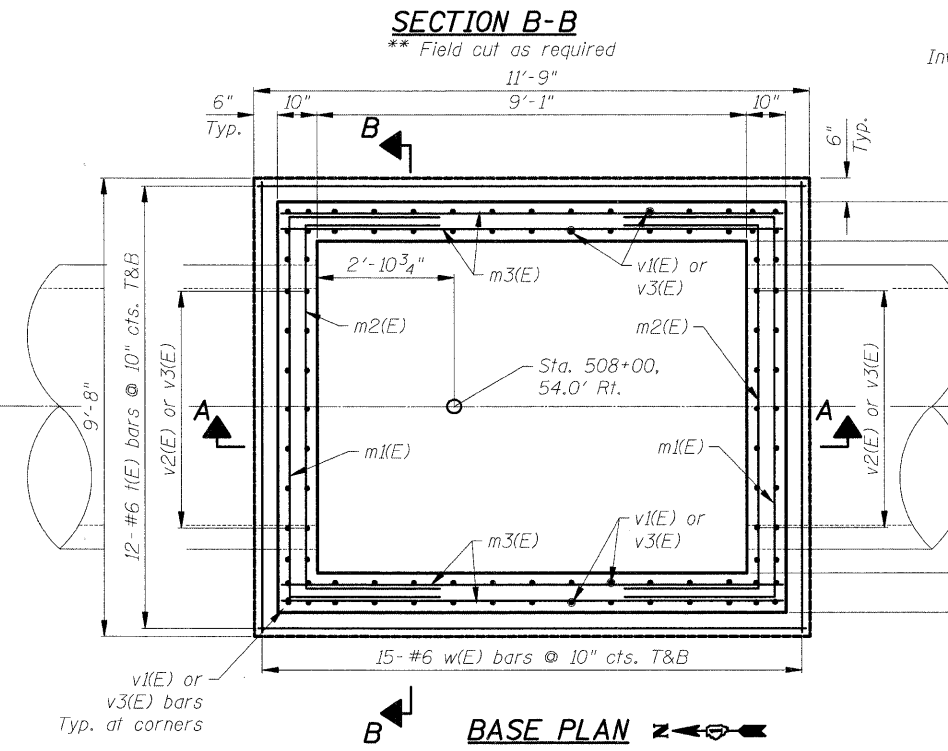
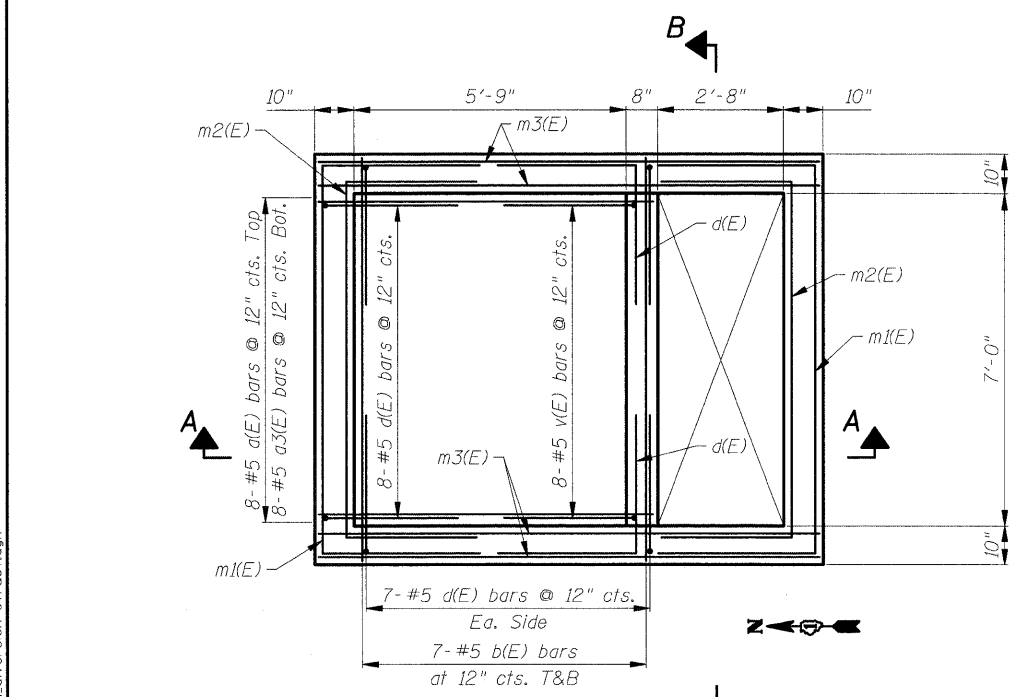
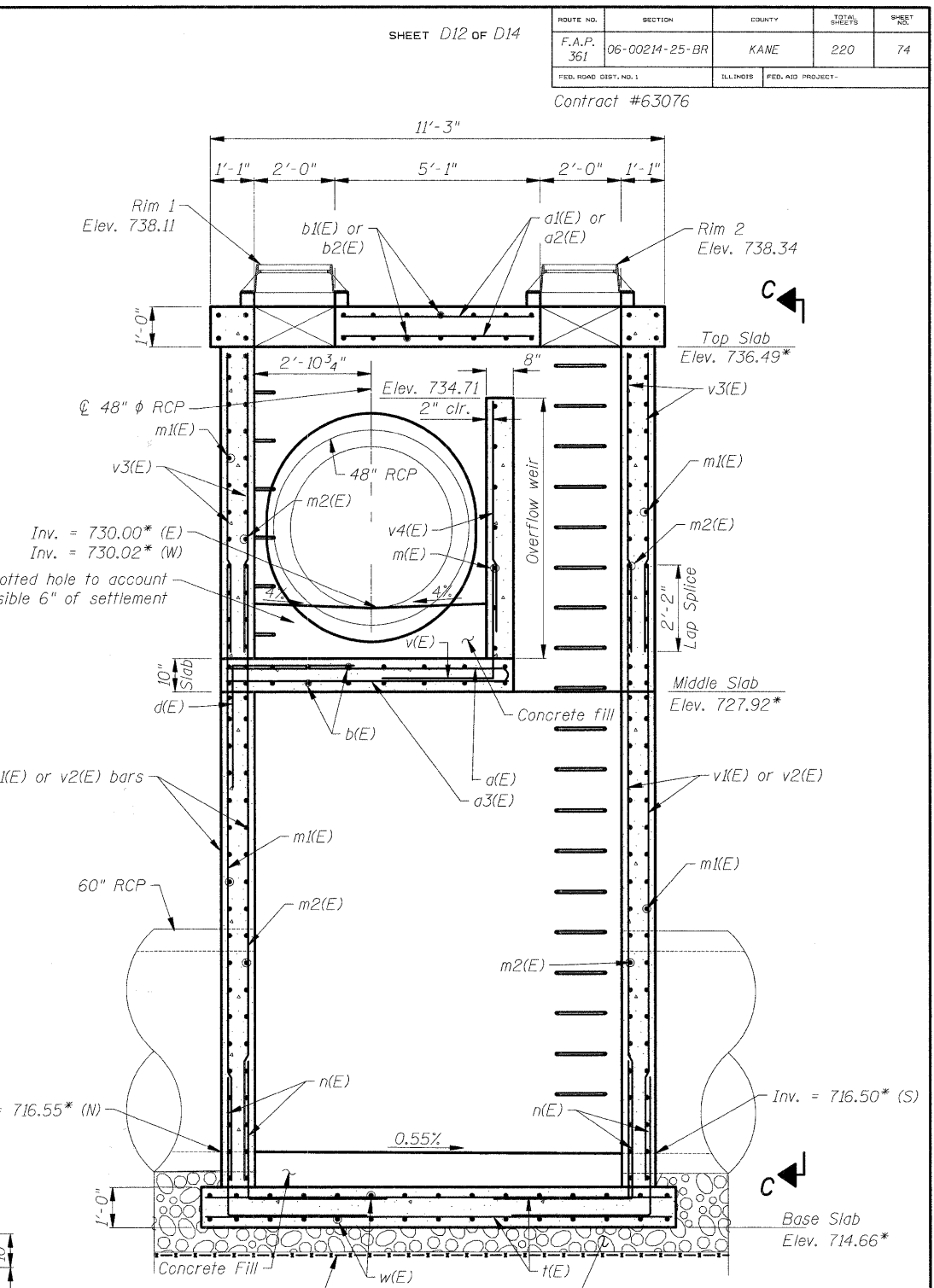
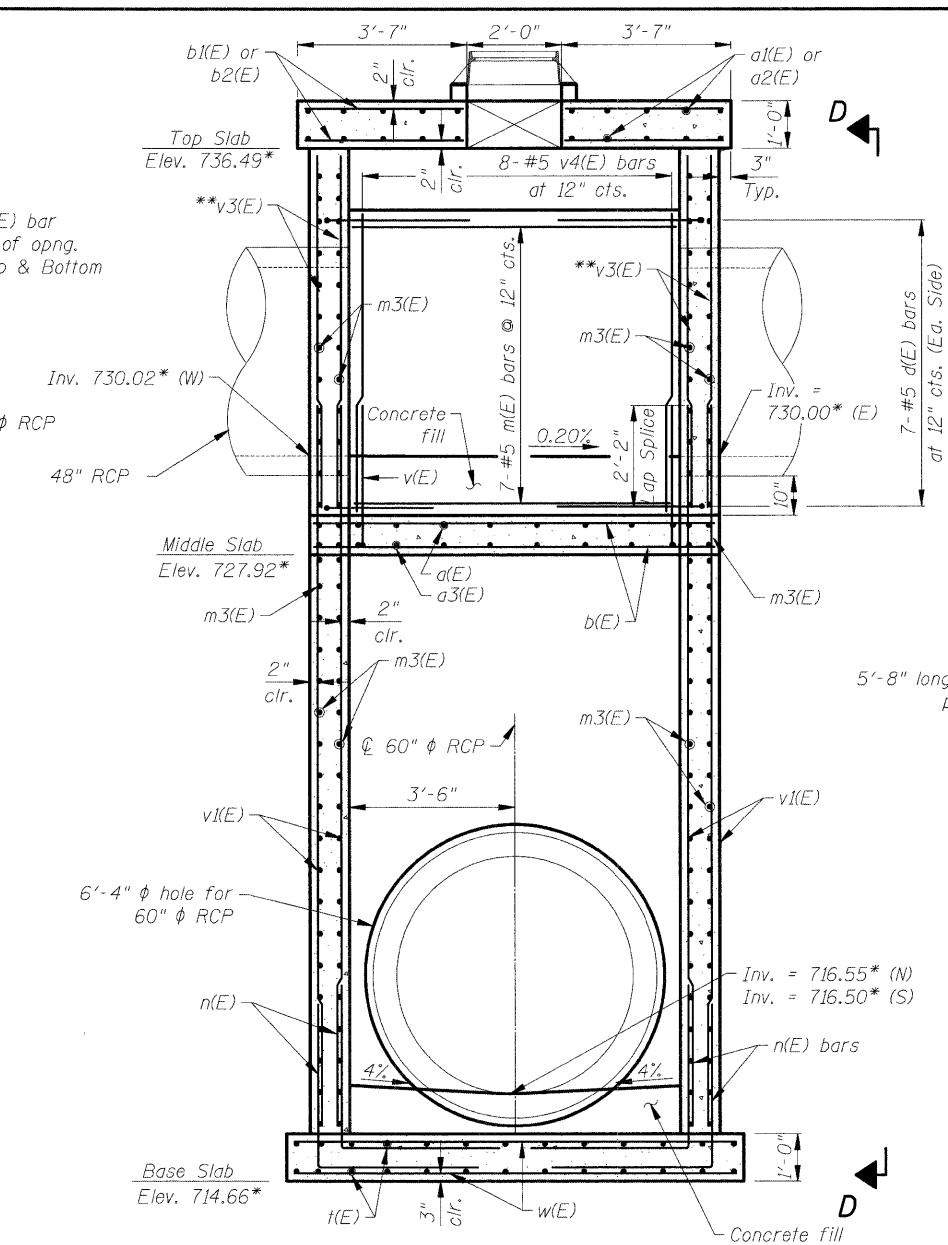
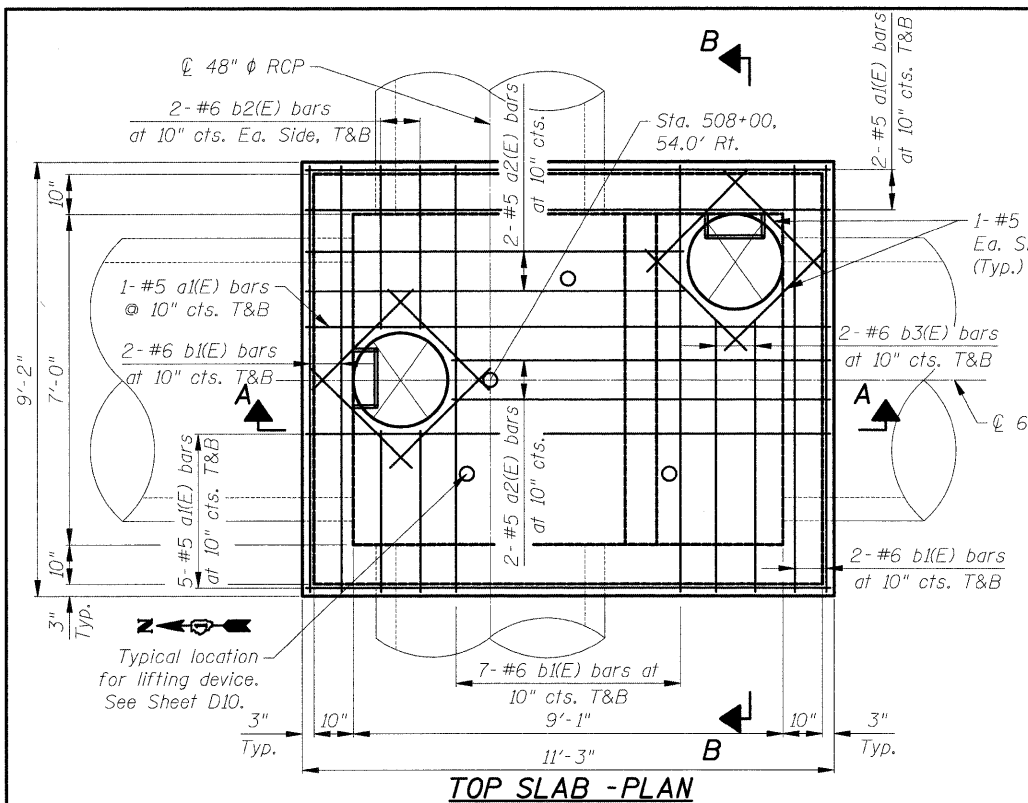

NOTES:

1. See standard 602701 for details of manhole steps.
2. See sheet D10 for Reinforcement Bill of Material and bar bend information.
3. *Indicates that elevations have been adjusted for the anticipated 6" of settlement.

REVISIONS	
NAME	DATE

ILLINOIS DEPARTMENT OF TRANSPORTATION

DIVERSION STRUCTURE DETAILS I

STEARNS ROAD (FAP 361)
STA. 508+00
SECTION 06-00214-25-BR
KANE COUNTY

SCALE: None
DRAWN BY: M. Lange
DATE: December 19, 2008
CHECKED BY: G. Hatlestad

ROUTE NO. F.A.P. 361	SECTION 06-00214-25-BR	COUNTY KANE	TOTAL SHEETS 220	SHEET NO. 75
FED. ROAD DIST. NO. 1		ILLINOIS	FED. AID PROJECT-	

Contract #63076

BAR LIST

BAR	NO.	SIZE	LENGTH	SHAPE
d(E)	8	#5	7'-5"	┌
d1(E)	16	#5	10'-11"	—
a2(E)	8	#5	7'-10"	—
a3(E)	8	#5	6'-11"	—
b(E)	14	#5	8'-4"	—
b1(E)	22	#6	8'-10"	—
b2(E)	8	#6	3'-3"	—
b3(E)	4	#6	5'-9"	—
d(E)	36	#5	6'-0"	L
m(E)	7	#5	6'-8"	—
m1(E)	66	#5	15'-1"	┌
m2(E)	66	#5	13'-7"	┌
m3(E)	132	#5	10'-5"	—
n(E)	84	#5	6'-4"	L
k(E)	24	#6	11'-5"	—
v(E)	8	#5	5'-10"	┌
v1(E)	60	#5	15'-3"	—
v2(E)	28	#5	9'-9"	—
v3(E)	88	#5	7'-5"	—
v4(E)	8	#5	5'-8"	—
w(E)	30	#6	9'-3"	—
w1(E)	16	#5	3'-0"	—
w2(E)	8	#5	13'-3"	┌
w3(E)	8	#5	11'-10"	┌
ITEM	UNIT	QUANTITY		
Concrete Structures	Cu. Yd.	29.6		
Reinforcement Bars, Epoxy Coated	Pound	8,010		

ITEM	UNIT	QUANTITY
Concrete Structures	Cu. Yd.	29.6
Reinforcement Bars, Epoxy Coated	Pound	8,010

* For information only

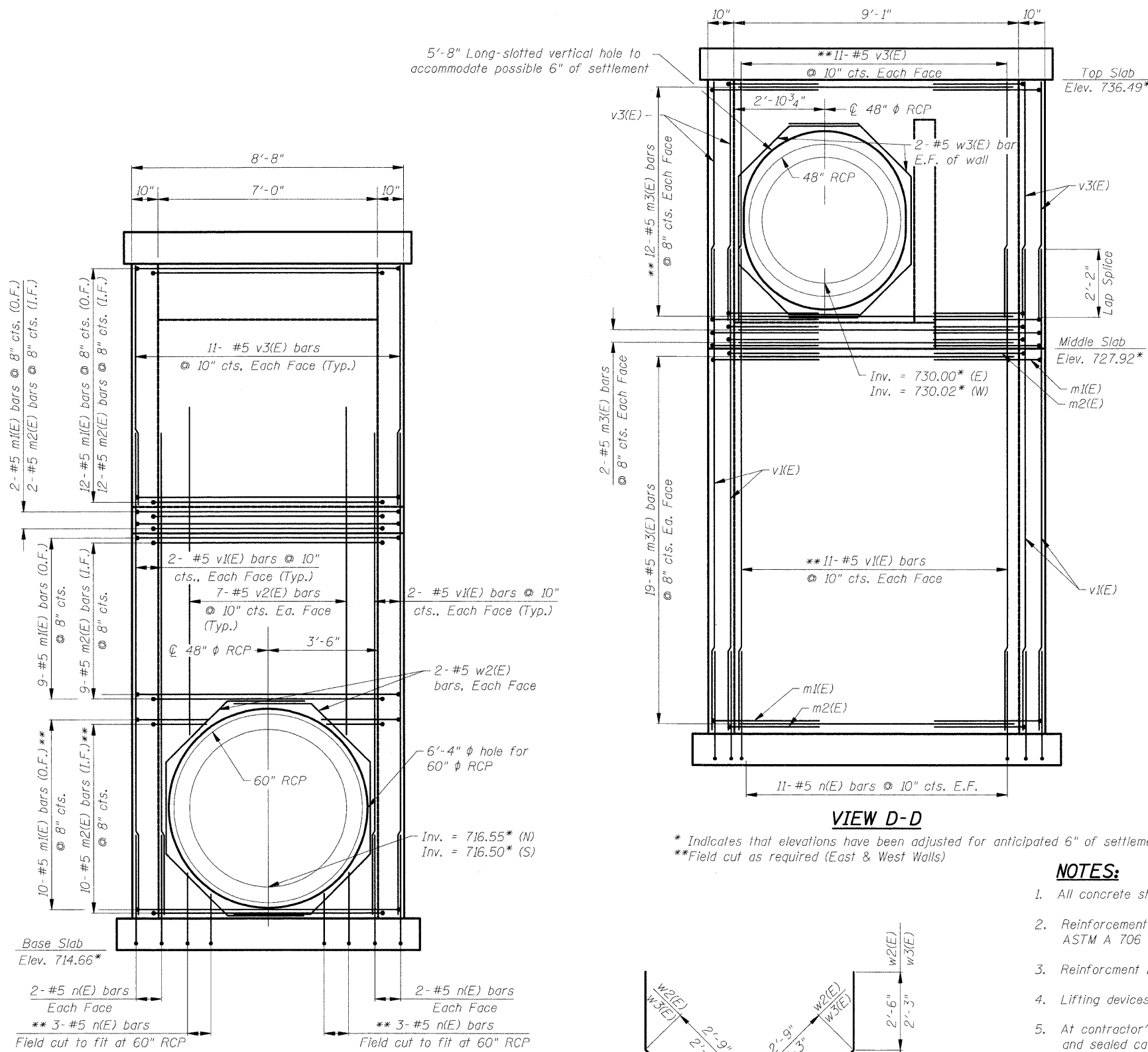

VIEW D-D

* Indicates that elevations have been adjusted for anticipated 6" of settlement.
**Field cut as required (East & West Walls)

VIEW C-C

* Indicates that elevations have been adjusted for anticipated 6" of settlement.
**Field cut as required (North & South Walls)

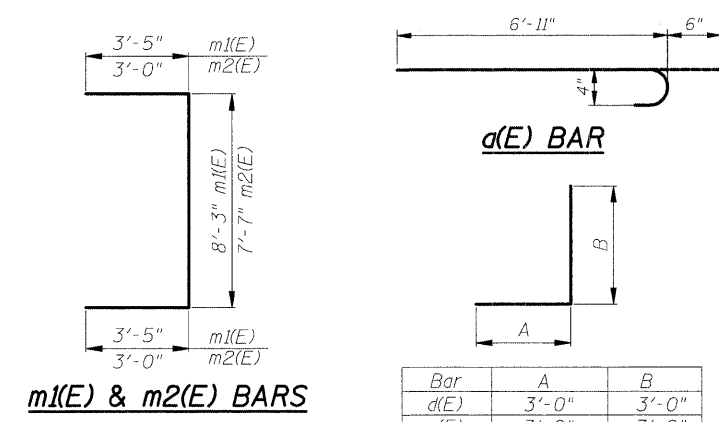

Bar	A	B
d(E)	3'-0"	3'-0"
n(E)	3'-2"	3'-2"
v(E)	2'-4"	3'-6"

d(E), v(E), n(E) BARS

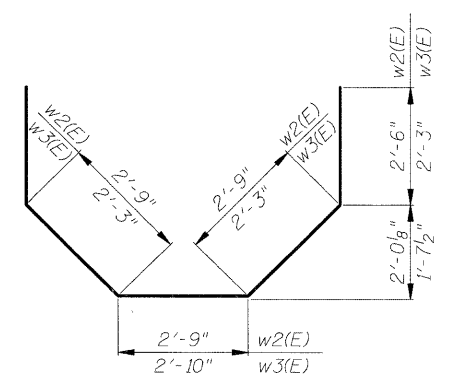
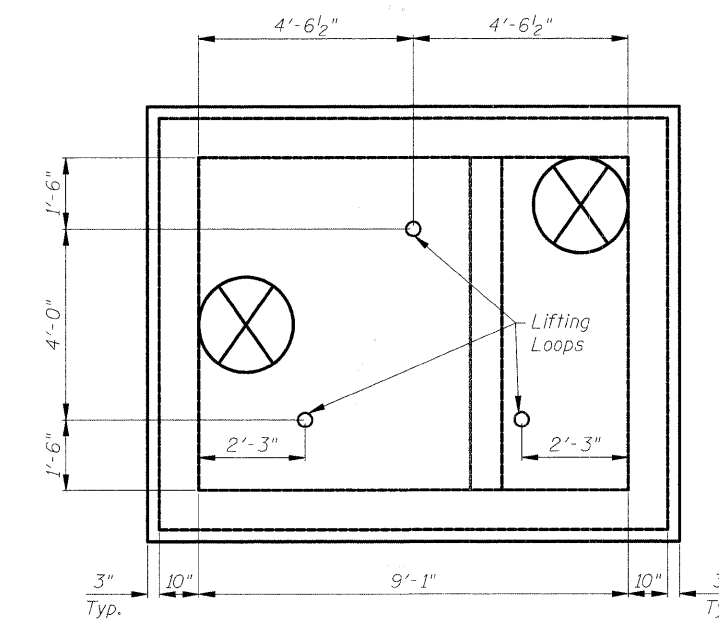

NOTES:

- All concrete shall be class SI Concrete.
- Reinforcement bars shall conform to the requirements of ASTM A 706 Gr 60. See Special Provision.
- Reinforcement bars designated (E) shall be epoxy coated.
- Lifting devices shall be approved by the Engineer.
- At contractor's option, vault can be precast. Submit signed and sealed calculations by an SE in the State of Illinois and shop drawings for approval.
- *Indicates that elevations have been adjusted for the anticipated 6" settlement.
- Neither the construction of the Overflow Weir or the 48" ϕ RCP shall begin until after the roadway and retaining wall have been in place for at least 5 months, at which time two thirds of the anticipated settlement is assumed to have occurred, unless otherwise directed by the Engineer. The Top Slab shall be on the Diversion Structure during the settlement period and may be removed for the construction of the Overflow Weir.

BILL OF MATERIAL

ITEM	UNIT	TOTAL
** Diversion Structure	Each	1

** - See special provision.

ILLINOIS DEPARTMENT OF TRANSPORTATION

DIVERSION STRUCTURE DETAILS

**STEARNS ROAD (FAP 361)
STATION 508+00
KANE COUNTY**

SCALE: None DRAWN BY: M. Lange
DATE: December 19, 2008 CHECKED BY: G. Hatlestad

REVISIONS	
NAME	DATE

J:\215\road\Struct\drain_struct\02_diversion_Struct.dgn 6/31/24 PM 6:31:24 PM

ROUTE NO.	SECTION	COUNTY	TOTAL SHEETS	SHEET NO.
F.A.P. 361	06-00214-25-BR	KANE	220	76
FED. ROAD DIST. NO. 1		ILLINOIS	FED. AID PROJECT-	

Contract #63076

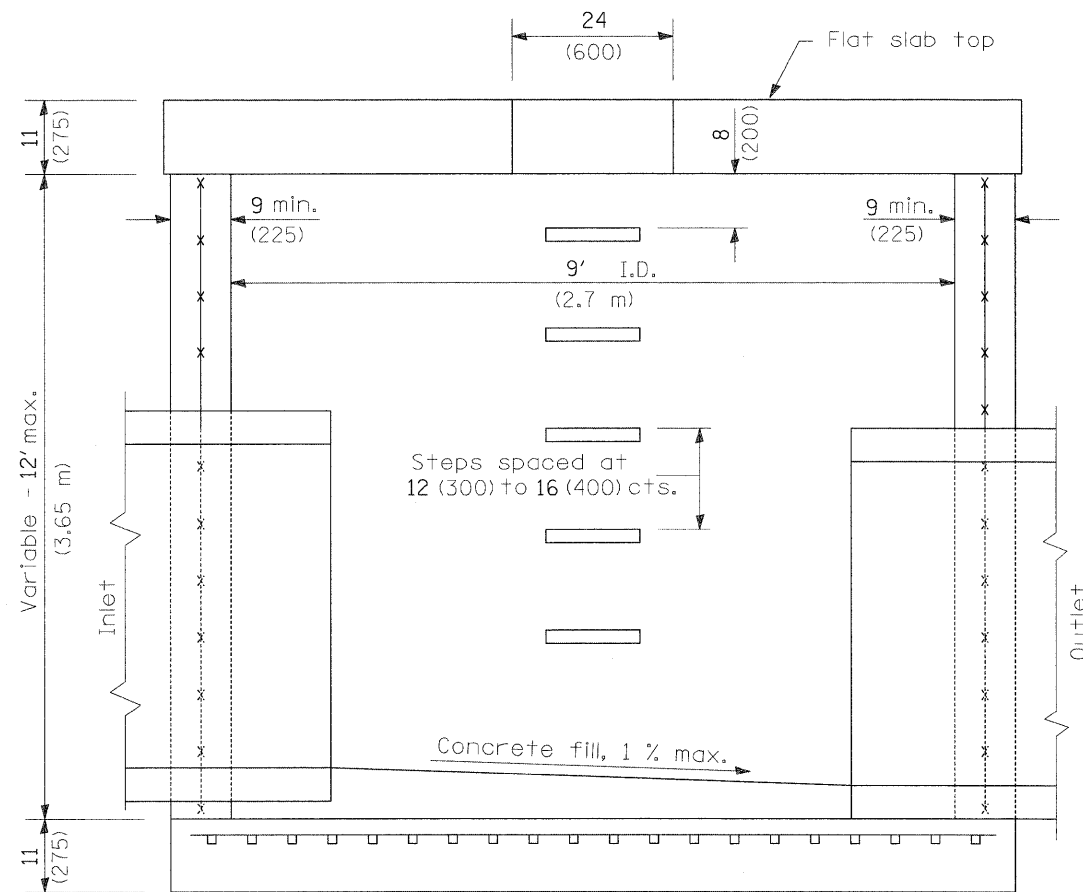

ELEVATION
(With Flat Slab Top Only)

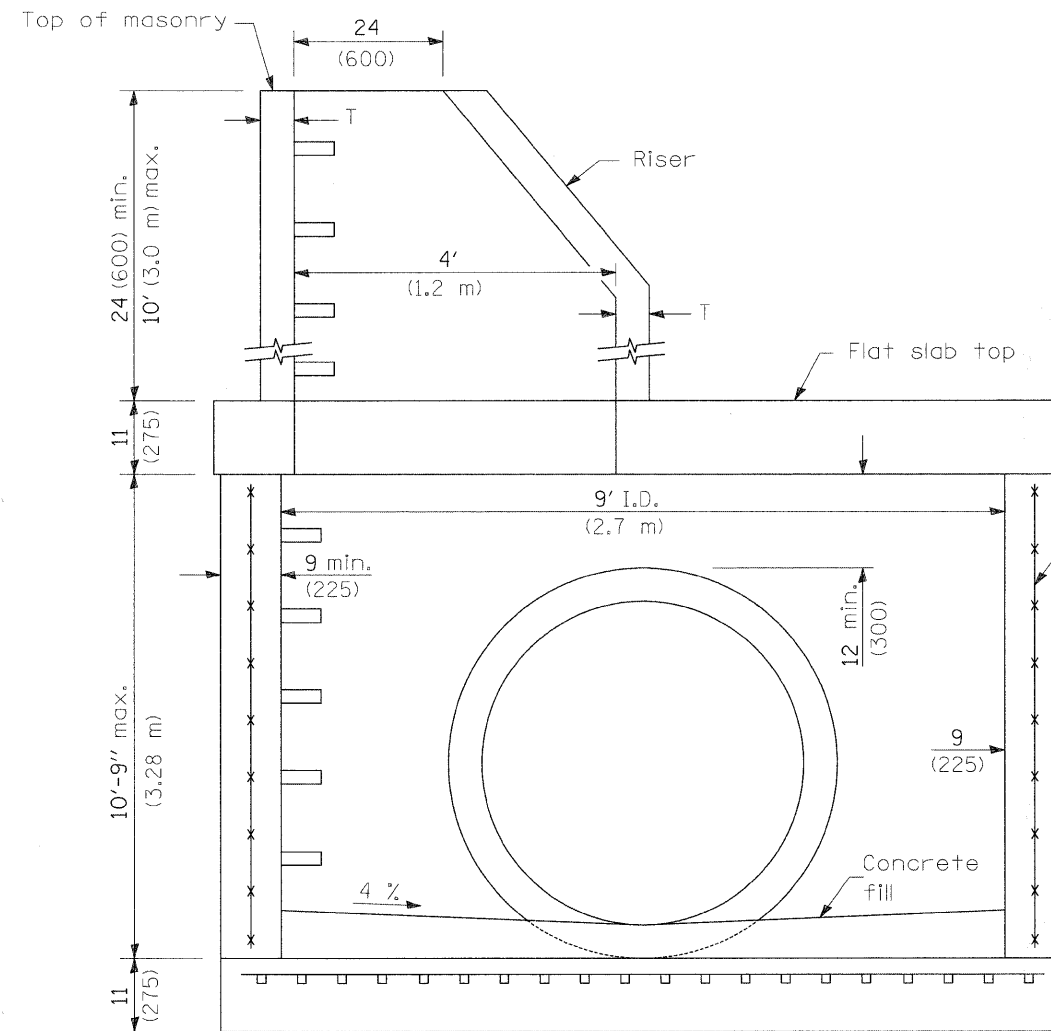

ELEVATION
(With Flat Slab Top and Riser)

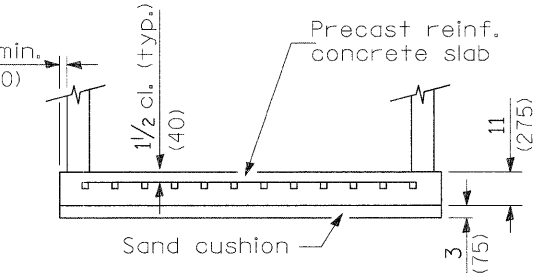
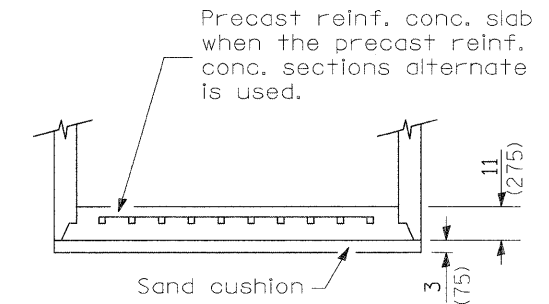

ALTERNATE BOTTOM SLABS

GENERAL NOTES

Joint configuration and dimensions of flat slab top shall match and fit the riser joint detail.

Lifting devices shall be approved by the Engineer.

Bottom slabs shall be reinforced with a minimum of 0.67 sq. in./ft. (1420 sq. mm/m) in both directions.

See Standard 602701 for details of manhole steps.

See Standard 602421 for details of the Top Slab.

All dimensions are in inches (millimeters) unless otherwise shown.

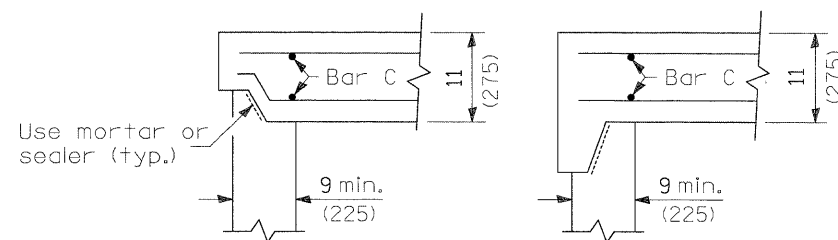

ALTERNATE JOINT CONFIGURATIONS

ALTERNATE MATERIALS FOR RISER WALLS	T (min)
Concrete Masonry Units	5 (125)
Precast Reinforced Concrete Sections	4 (100)
Cast-in-Place Concrete	6 (150)

ILLINOIS DEPARTMENT OF TRANSPORTATION

SPECIAL 9 FT DIA. MANHOLE

STEARNS ROAD (FAP 361)
STA. 508+00
SECTION 06-00214-25-BR
KANE COUNTY

SCALE: None
DATE: December 19, 2008

DRAWN BY:
CHECKED BY:

REVISIONS	
NAME	DATE

15m 3/27/2009 6:31:50 PM J:\2115\road\struct\drain_struct\03_9ft-dia_mh\slab.dgn

450 E Devon Ave, Suite 300
Itasca, Illinois 60143
Tel: 630.773.3900 Fax: 630.773.3975
www.civiltechinc.com



NOTE:

FOR TEST HOLE INFORMATION SEE SPECIFICATIONS, "VERIFIED UTILITY LOCATIONS."

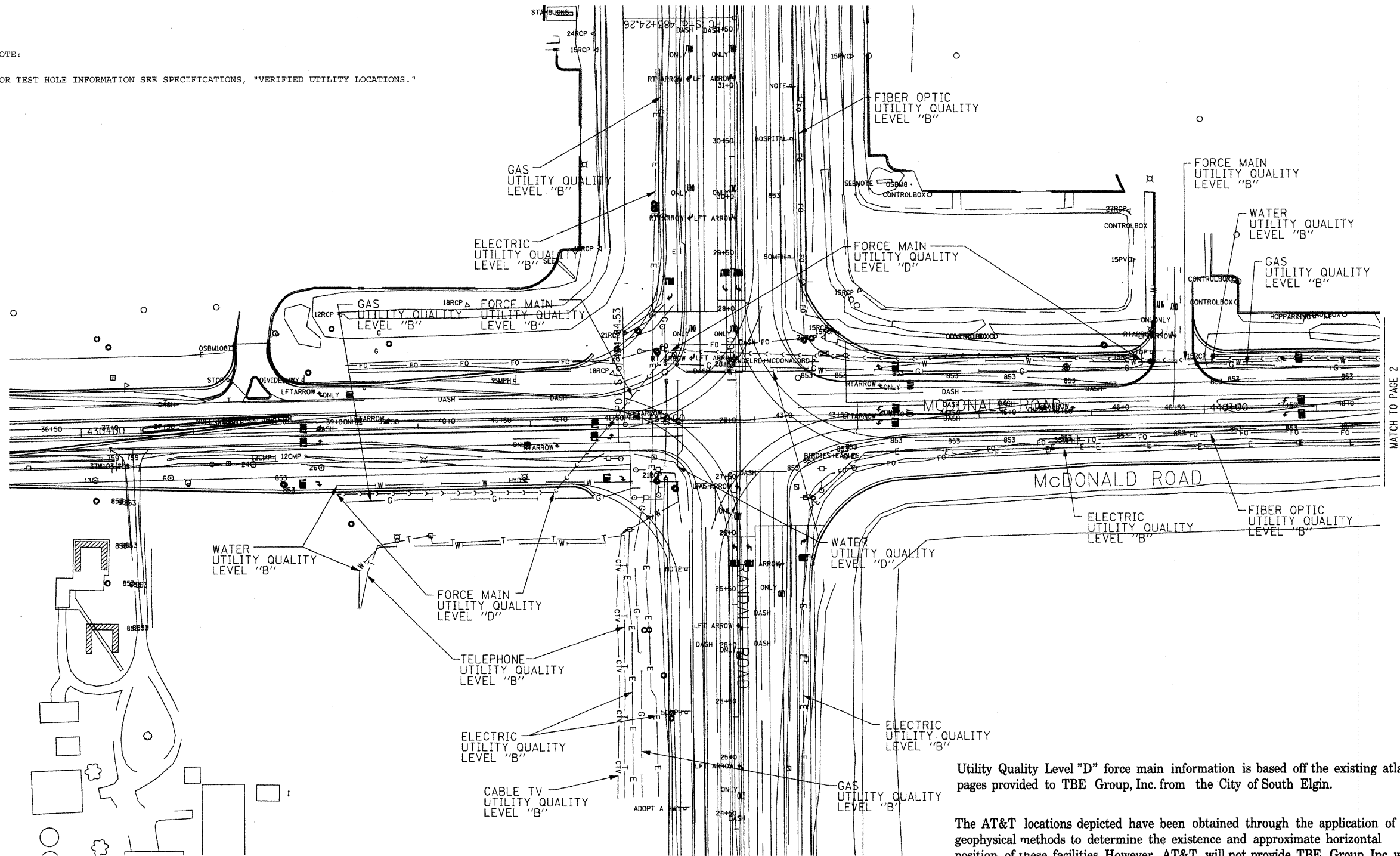

MATCH TO PAGE 2

Utility Quality Level "D" force main information is based off the existing atlas pages provided to TBE Group, Inc. from the City of South Elgin.

The AT&T locations depicted have been obtained through the application of geophysical methods to determine the existence and approximate horizontal position of these facilities. However, AT&T will not provide TBE Group, Inc. with utility records nor allow access to their field closures (pedestals/manholes etc.), to help verify the locations of their existing underground facilities. Therefore, TBE is unable to verify the completeness of the AT&T locations depicted in accordance with the CIASCE Standard 38-02.

205 W. WACKER DRIVE
SUITE 1020
CHICAGO, IL 60606
(312) 704-1970

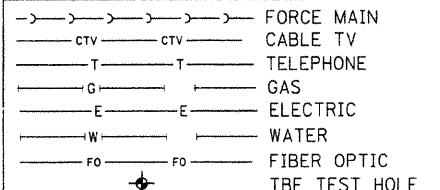

Utilities shown in color on these plans as depicted in the legend have been investigated by TBE Group, Inc in accordance with SUE Industry Standards. All other information shown has been provided to TBE Group, Inc by others. TBE's SUE field investigation was performed from 3/24/08 to 6/13/08. Changes to utilities after this date may have been made and therefore may result in variances from this plan. Consideration should be given to updating this plan if deemed advisable prior to final design and construction.

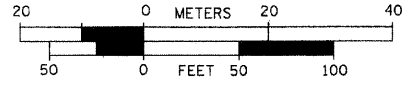

TBE GROUP, INC.
CIVIL ENGINEERING • TRANSPORTATION • ENVIRONMENTAL
PLANNING • UTILITY ENGINEERING/LOCATING

- Utility Quality Level "A" : Test Hole
- Utility Quality Level "B" : Designating
- Utility Quality Level "C" : Research with Survey
- Utility Quality Level "D" : Records Research

Checked By: Robert Clemens
Date: 1/01/09

TBE Job No. IL09500274,
284, 285, 286, 288
SUE Plan Page: 1 of 21

FILE NAME =	USER NAME =	DESIGNED <u>EG, IP, SW</u>	REVISED
*FILE#	DRAWN <u>KLC</u>	CHECKED <u>RLC</u>	REVISED
PLOT SCALE =	DATE <u>6/16/08</u>		REVISED
PLOT DATE = #DATE#			REVISED

**STATE OF ILLINOIS
DEPARTMENT OF TRANSPORTATION
AND KANE COUNTY HIGHWAY DEPT.**

STEARNS ROAD CORRIDOR

SCALE: SHEET NO. STA. TO STA.

F.A. RTE.	SECTION	COUNTY	TOTAL SHEETS	SHEET NO.
361	N/A	KANE/DuPAGE	220	77
CONTRACT NO. 2, 3, 4, 5				
FED. ROAD DIST. NO.	ILLINOIS	Job No.:		

NOTE:
FOR TEST HOLE INFORMATION SEE SPECIFICATIONS, "VERIFIED UTILITY LOCATIONS."

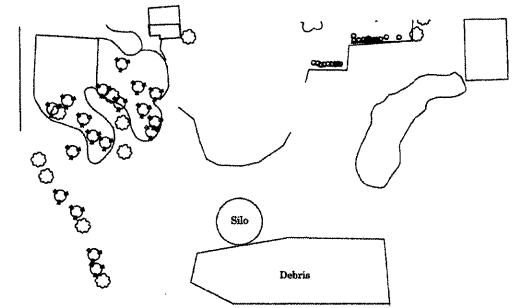
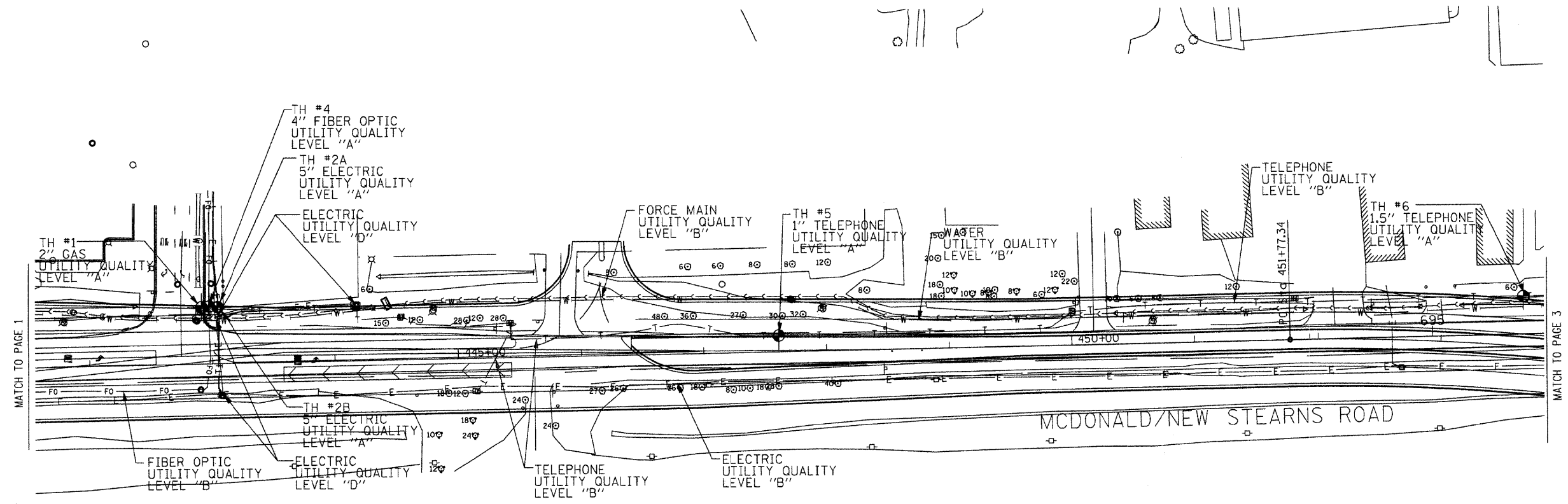
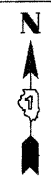

Utility Quality Level "D" electric information is based off field investigation but has not been surveyed.

The AT&T locations depicted have been obtained through the application of geophysical methods to determine the existence and approximate horizontal position of these facilities. However, AT&T will not provide TBE Group, Inc. with utility records nor allow access to their field closures (pedestals/manholes etc.), to help verify the locations of their existing underground facilities. Therefore, TBE is unable to verify the completeness of the AT&T locations depicted in accordance with the CIASCE Standard 38-02.

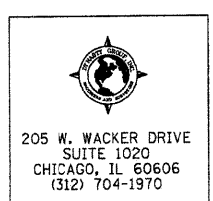

—●—●—●—●—●—	FORCE MAIN
—CTV—CTV—	CABLE TV
—T—T—	TELEPHONE
—G—G—	GAS
—E—E—	ELECTRIC
—W—W—	WATER
—FO—FO—	FIBER OPTIC
—○—	TBE TEST HOLE

Utilities shown in color on these plans as depicted in the legend have been investigated by TBE Group, Inc. in accordance with SUE Industry Standards. All other information shown has been provided to TBE Group, Inc. by others. TBE's SUE QL "B" field investigation was performed from 3/24/08 to 6/13/08. TBE's SUE QL "A" field investigation was performed from 11/19/08 to 1/05/09. Changes to utilities after 6/13/08 may have been made and therefore may result in variances from this plan. Consideration should be given to updating this plan if deemed advisable prior to final design and construction.

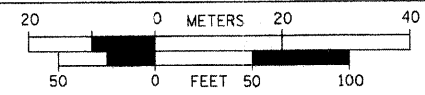

TBE GROUP, INC.
CIVIL ENGINEERING • TRANSPORTATION • ENVIRONMENTAL
PLANNING • UTILITY ENGINEERING/LOCATING

Checked By: Robert Clemens
Date: 1/26/09

TBE Job No. IL09500274,
284, 285, 286, 288, 289
SUE Plan Page: 2 of 21

FILE NAME =	USER NAME =	DESIGNED <u>EG, IP, SW</u>	REVISED
*FILE#	DRAWN <u>KLC</u>	CHECKED <u>RLC</u>	REVISED
PLOT SCALE =	DATE <u>1/26/09</u>		

STATE OF ILLINOIS
DEPARTMENT OF TRANSPORTATION
AND KANE COUNTY HIGHWAY DEPT.

STEARNS ROAD CORRIDOR

SCALE: SHEET NO. STA. TO STA.

F.A. RTE.	SECTION	COUNTY	TOTAL SHEETS	SHEET NO.
361	N/A	KANE/DUPAGE	220	78
CONTRACT NO. 2, 3, 4, 5				
FED. ROAD DIST. NO. ILLINOIS Job No.:				

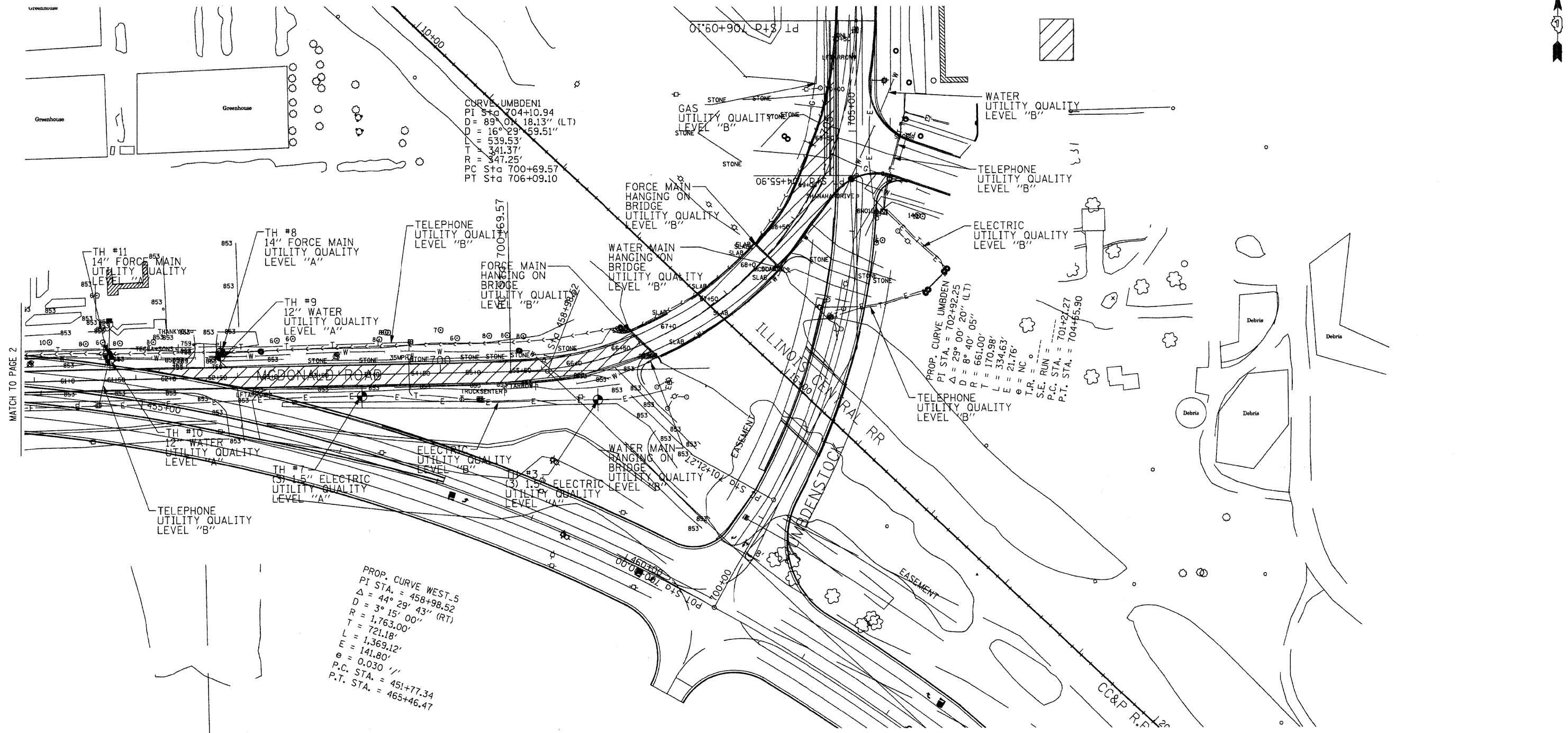

MATCH TO PAGE 2

CURVE UMBDENI
 PI STA = 704+10.94
 D = 89° 01' 18.13" (LT)
 D = 16° 29' 59.51"
 L = 539.53'
 T = 341.37'
 R = 347.25'
 PC STA 700+69.57
 PT STA 706+09.10

PROP. CURVE UMBDEN
 PI STA. = 702+92.25
 Δ = 29° 00' 20" (LT)
 D = 8° 40' 05"
 R = 661.00'
 T = 170.98'
 L = 334.63'
 E = 21.76'
 θ = NC
 S.E. RUN =
 P.C. STA. = 701+21.27
 P.T. STA. = 704+65.90

PROP. CURVE WEST-5
 PI STA. = 458+98.52
 Δ = 44° 29' 43" (RT)
 D = 3° 15' 00"
 R = 1,763.00'
 T = 721.18'
 L = 1,369.12'
 E = 141.80'
 θ = 0.030
 P.C. STA. = 451+77.34
 P.T. STA. = 465+46.47

NOTE:
 FOR TEST HOLE INFORMATION SEE SPECIFICATIONS, "VERIFIED UTILITY LOCATIONS."

The AT&T locations depicted have been obtained through the application of geophysical methods to determine the existence and approximate horizontal position of these facilities. However, AT&T will not provide TBE Group, Inc. with utility records nor allow access to their field closures (pedestals/manholes etc.), to help verify the locations of their existing underground facilities. Therefore, TBE is unable to verify the completeness of the AT&T locations depicted in accordance with the CIASCE Standard 38-02.

205 W. WACKER DRIVE
 SUITE 1020
 CHICAGO, IL 60606
 (312) 704-1970

- FORCE MAIN
- CABLE TV
- TELEPHONE
- GAS
- ELECTRIC
- WATER
- FIBER OPTIC
- TBE TEST HOLE

Utilities shown in color on these plans as depicted in the legend have been investigated by TBE Group, Inc in accordance with SUE Industry Standards. All other information shown has been provided to TBE Group, Inc by others. TBE's SUE QL "B" field investigation was performed from 3/24/08 to 6/13/08. TBE's SUE QL "A" field investigation was performed from 11/19/08 to 1/05/09. Changes to utilities after 6/13/08 may have been made and therefore may result in variances from this plan. Consideration should be given to updating this plan if deemed advisable prior to final design and construction.

- Utility Quality Level "A" : Test Hole
- Utility Quality Level "B" : Designating
- Utility Quality Level "C" : Research with Survey
- Utility Quality Level "D" : Records Research

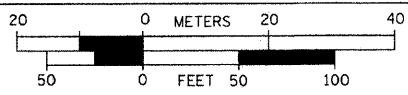

TBE GROUP, INC.
 CIVIL ENGINEERING • TRANSPORTATION • ENVIRONMENTAL
 PLANNING • UTILITY ENGINEERING/LOCATING

Checked By: *Robert Stevens*
 Date: 1/26/09

TBE Job No. IL09500274,
 284, 285, 286, 288, 289
 SUE Plan Page: 3 of 21

FILE NAME =	USER NAME =	DESIGNED <i>EG, JP, SW</i>	REVISED
#FILE#	DRAWN <i>KLC</i>	CHECKED <i>RLC</i>	REVISED
	PLOT SCALE =	DATE <i>1/26/09</i>	REVISED
	PLOT DATE = #DATE#		

STATE OF ILLINOIS
DEPARTMENT OF TRANSPORTATION
AND KANE COUNTY HIGHWAY DEPT.

STEARNS ROAD CORRIDOR

SCALE: SHEET NO. STA. TO STA.

F.A. RTE.	SECTION	COUNTY	TOTAL SHEETS	SHEET NO.
361	N/A	KANE/DUPAGE	220	79
CONTRACT NO. 2, 3, 4, 5				
FED. ROAD DIST. NO.	ILLINOIS	Job No.:		

PART OF THE NW 1/4 OF SECTION 4, TOWNSHIP 40 N, RANGE 8 E OF THE 3RD P.M., KANE COUNTY, ILLINOIS

CONTRACT NO.	TOTAL SHEETS	SHEET NO.
63076	220	80

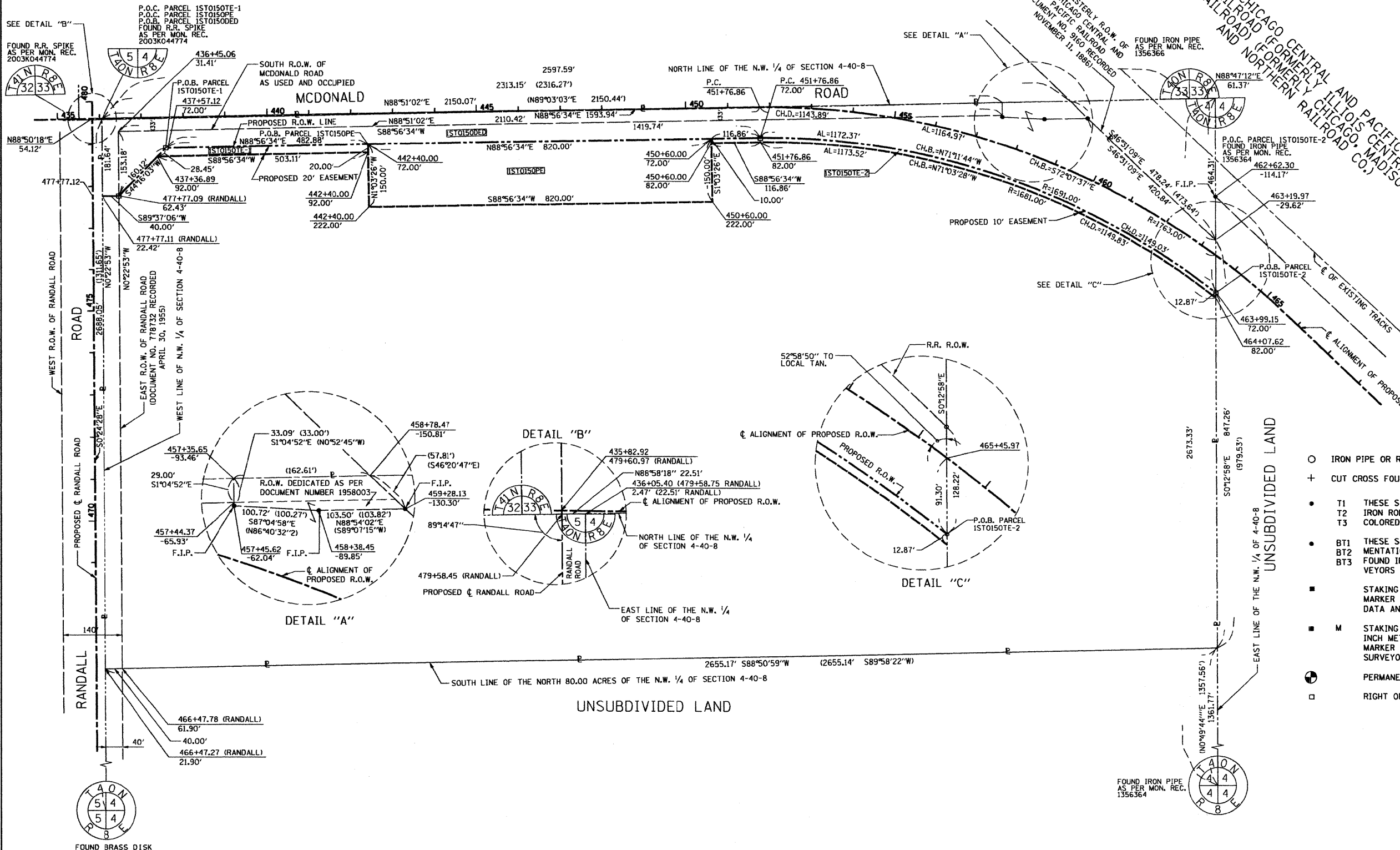

LEGEND

- SECTION CORNER
- QUARTER SECTION CORNER
- SECTION LINE
- QUARTER SECTION LINE
- QUARTER SECTION LINE
- PLATTED LOT LINE
- PROPERTY (DEED) LINE
- APL
- APPARENT PROPERTY LINE
- EXISTING CENTER LINE
- PROPOSED CENTER LINE
- EXISTING RIGHT OF WAY LINE
- PROPOSED RIGHT OF WAY LINE
- PROPOSED EASEMENT
- MEASURED DIMENSION
- COMPUTED DIMENSION
- RECORD DATA
- EXISTING BUILDING

Bearings are referenced to the Illinois State Plane Coordinate System, East Zone, NAD 1983.

- IRON PIPE OR ROD FOUND
- ⊕ "MAG" NAIL SET
- + CUT CROSS FOUND OR SET
- 5/8" REBAR SET
- T1 THESE STAKES REFERENCE FOUND OR SET MONUMENTATION. SET 5/8 INCH IRON ROD FLUSH WITH GROUND TO TIE FOUND IRON STAKE. IDENTIFIED BY COLORED PLASTIC CAP BEARING SURVEYORS REGISTRATION NUMBER.
- T2 THESE STAKES REFERENCE FOUND OR SET MONUMENTATION. SET 5/8 INCH IRON ROD 20 INCHES BELOW GROUND TO TIE FOUND IRON STAKE. IDENTIFIED BY COLORED PLASTIC CAP BEARING SURVEYORS REGISTRATION NUMBER.
- BT1 THESE STAKES IN CULTIVATED AREAS, REFERENCE FOUND OR SET MONUMENTATION. BURIED 5/8 INCH IRON ROD 20 INCHES BELOW GROUND TO TIE FOUND IRON STAKE. IDENTIFIED BY COLORED PLASTIC CAP BEARING SURVEYORS REGISTRATION NUMBER.
- BT2
- BT3
- STAKING OF PROPOSED RIGHT OF WAY, SET DIVISION OF HIGHWAYS SURVEY MARKER TO MONUMENT THE POSITION SHOWN. IDENTIFIED BY INSCRIPTION DATA AND SURVEYORS REGISTRATION NUMBER.
- M STAKING OF PROPOSED RIGHT OF WAY IN CULTIVATED AREAS. BURIED 5/8 INCH METAL ROD 20 INCHES BELOW GROUND TO MARK FUTURE SURVEY MARKER POSITION IDENTIFIED BY COLORED PLASTIC CAP BEARING SURVEYORS REGISTRATION NUMBER.
- ⊕ PERMANENT SURVEY MARKER, I.D.O.T. STD 2135 (TO BE SET BY OTHERS)
- RIGHT OF WAY STAKING PROPOSED TO BE SET.

COUNTY OF COOK:
STATE OF ILLINOIS:

THIS IS TO CERTIFY THAT I, RONALD W. SODERQUIST, AN ILLINOIS PROFESSIONAL LAND SURVEYOR, NUMBER 2722, HAVE SURVEYED THE PLAT OF HIGHWAYS SHOWN HEREON IN SECTION 4, TOWNSHIP 40 N., RANGE 8E., OF THE THIRD PRINCIPAL MERIDIAN, KANE COUNTY, THAT THE SURVEY IS TRUE AND COMPLETE AS SHOWN TO THE BEST OF MY KNOWLEDGE AND BELIEF, THAT THE PLAT CORRECTLY REPRESENTS SAID SURVEY, THAT ALL MONUMENTS FOUND AND ESTABLISHED ARE OF PERMANENT QUALITY AND OCCUPY THE POSITIONS SHOWN THEREON AND THAT THE MONUMENTS ARE SUFFICIENT TO ENABLE THE SURVEY TO BE RETRACED.

SEPTEMBER 21, 2005

RONALD W. SODERQUIST
ILLINOIS PROFESSIONAL LAND SURVEYOR NO. 2722
LICENSE EXPIRATION DATE: NOVEMBER 30, 2008

NOTES

- ALL STATIONS HEREON REFERENCED ARE TO THE PROPOSED CENTERLINE STATIONINGS.
- SUBJECT TO EASEMENTS, IF ANY, AS PER THE FOLLOWING DOCUMENT NUMBERS: 1999K048999, & 967988.
- BASIS OF BEARINGS: ALL BEARINGS DEPICTED AS MEASURED HEREON ARE REFERENCED TO THE ILLINOIS STATE PLANE COORDINATE SYSTEM, EAST ZONE (WGS 84).

PARCEL NUMBER	OWNER	TOTAL HOLDINGS ACRES	AREA TAKEN ACRES	PREVIOUS DEDICATION ACRES	AREA REMAINING ACRES	AREA OF EASEMENT ACRES	PURPOSE OF EASEMENT	PERMANENT INDEX NUMBER	PROPERTY ACQUIRED BY
ISTO1500ED	LIOUBOV GRANT	78.655	6.377	1.733	78.655	0.000	N/A	09-04-100-022	
ISTO150PE	ROBERT G. TURNER SUCCESSOR TRUSTEE TO WALTER E. GRANT TRUSTEE OF THE WALTER E. GRANT REVOCABLE TRUST DATED APRIL 27, 1998		0.000	0.000	N/A	2.824	DETENTION	09-04-100-022	
ISTO150TE-1	NANCY J. WIECHMANN AND RODGER P. WIECHMANN		0.000	0.000	N/A	0.226	ROADWAY	09-04-100-022	
ISTO150TE-2	GILBERT H. HENDRICKSON AND LINDA M. HENDRICKSON AS TRUSTEES OF THE HENDRICKSON TRUST DATED DECEMBER 15, 2003		0.000	0.000	N/A	0.296	ROADWAY	09-04-100-022	

* AREA OF DEDICATION

REVISION	
DATE	DESCRIPTION
10-28-05	per Kane
10-17-07	Job Num.
4-04-08	DED
4-15-08	per Kane
4-22-08	New Com.
5-07-08	New TEs

PLAT OF HIGHWAYS
STATE OF ILLINOIS
DEPARTMENT OF TRANSPORTATION
Stearns Rd. (Fox River Bridges)

SECTION 98-00214-02-BR KANE COUNTY
PROJECT 477+77.11 (RANDALL) JOB NO. R-91-083-01
STATION 436+05.40 TO STATION 464+07.62
SCALE: 1"=120' SHEET 1 OF 1

BUREAU OF LAND ACQUISITION
201 WEST CENTER COURT
SCHAUMBURG, ILLINOIS 60196

benesch
alfred benesch & company
Engineers • Surveyors • Planners
205 North Michigan Avenue, Suite 2400
Chicago, Illinois 60601
312-565-0450
Design Firm License # 184.000882

PART OF THE SW 1/4 OF SECTION 33, TOWNSHIP 41N, RANGE 8 E OF THE 3RD P.M., KANE COUNTY, ILLINOIS

CONTRACT NO.	TOTAL SHEETS	SHEET NO.
63076	220	81

LEGEND

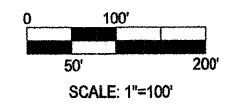
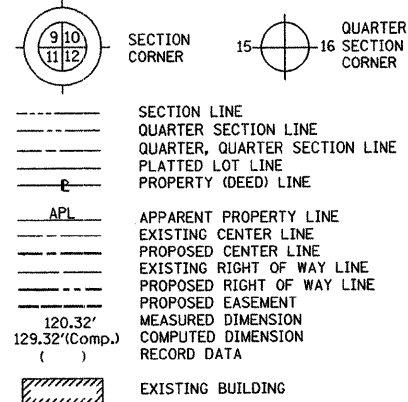

Bearings are referenced to the Illinois State Plane Coordinate System, East Zone, NAD 1983.

- IRON PIPE OR ROD FOUND ⊕ "MAG" NAIL SET
- + CUT CROSS FOUND OR SET • 5/8" REBAR SET
- T1 THESE STAKES REFERENCE FOUND OR SET MONUMENTATION. SET 5/8 INCH IRON ROD FLUSH WITH GROUND TO TIE FOUND IRON STAKE. IDENTIFIED BY COLORED PLASTIC CAP BEARING SURVEYORS REGISTRATION NUMBER.
- BT1 THESE STAKES IN CULTIVATED AREAS, REFERENCE FOUND OR SET MONUMENTATION. BURIED 5/8 INCH IRON ROD 20 INCHES BELOW GROUND TO THE FOUND IRON STAKE, IDENTIFIED BY COLORED PLASTIC CAP BEARING SURVEYORS REGISTRATION NUMBER.
- STAKING OF PROPOSED RIGHT OF WAY, SET DIVISION OF HIGHWAYS SURVEY MARKER TO MONUMENT THE POSITION SHOWN. IDENTIFIED BY INSCRIPTION DATA AND SURVEYORS REGISTRATION NUMBER.
- M STAKING OF PROPOSED RIGHT OF WAY IN CULTIVATED AREAS. BURIED 5/8 INCH METAL ROD 20 INCHES BELOW GROUND TO MARK FUTURE SURVEY MARKER POSITION IDENTIFIED BY COLORED PLASTIC CAP BEARING SURVEYORS REGISTRATION NUMBER.
- ⊕ PERMANENT SURVEY MARKER, I.D.O.T. STD 2135 (TO BE SET BY OTHERS)
- RIGHT OF WAY STAKING PROPOSED TO BE SET.

COUNTY OF COOK;
STATE OF ILLINOIS;

THIS IS TO CERTIFY THAT I, RONALD W. SODERQUIST, AN ILLINOIS PROFESSIONAL LAND SURVEYOR, NUMBER 2722, HAVE SURVEYED THE PLAT OF HIGHWAYS SHOWN HEREON IN SECTION 33, TOWNSHIP 41 N., RANGE 8E., OF THE THIRD PRINCIPAL MERIDIAN, KANE COUNTY, THAT THE SURVEY IS TRUE AND COMPLETE AS SHOWN TO THE BEST OF MY KNOWLEDGE AND BELIEF, THAT THE PLAT CORRECTLY REPRESENTS SAID SURVEY, THAT ALL MONUMENTS FOUND AND ESTABLISHED ARE OF PERMANENT QUALITY AND OCCUPY THE POSITIONS SHOWN THEREON AND THAT THE MONUMENTS ARE SUFFICIENT TO ENABLE THE SURVEY TO BE RETRACED.

DECEMBER 14, 2006

Ronald W. Soderquist
ILLINOIS PROFESSIONAL LAND SURVEYOR NO. 2722
LICENSE EXPIRATION DATE: NOVEMBER 30, 2008

RONALD W. SODERQUIST



alfred benesch & company
Engineers • Surveyors • Planners
205 North Michigan Avenue, Suite 2400
Chicago, Illinois 60601
312-685-0450

benesch

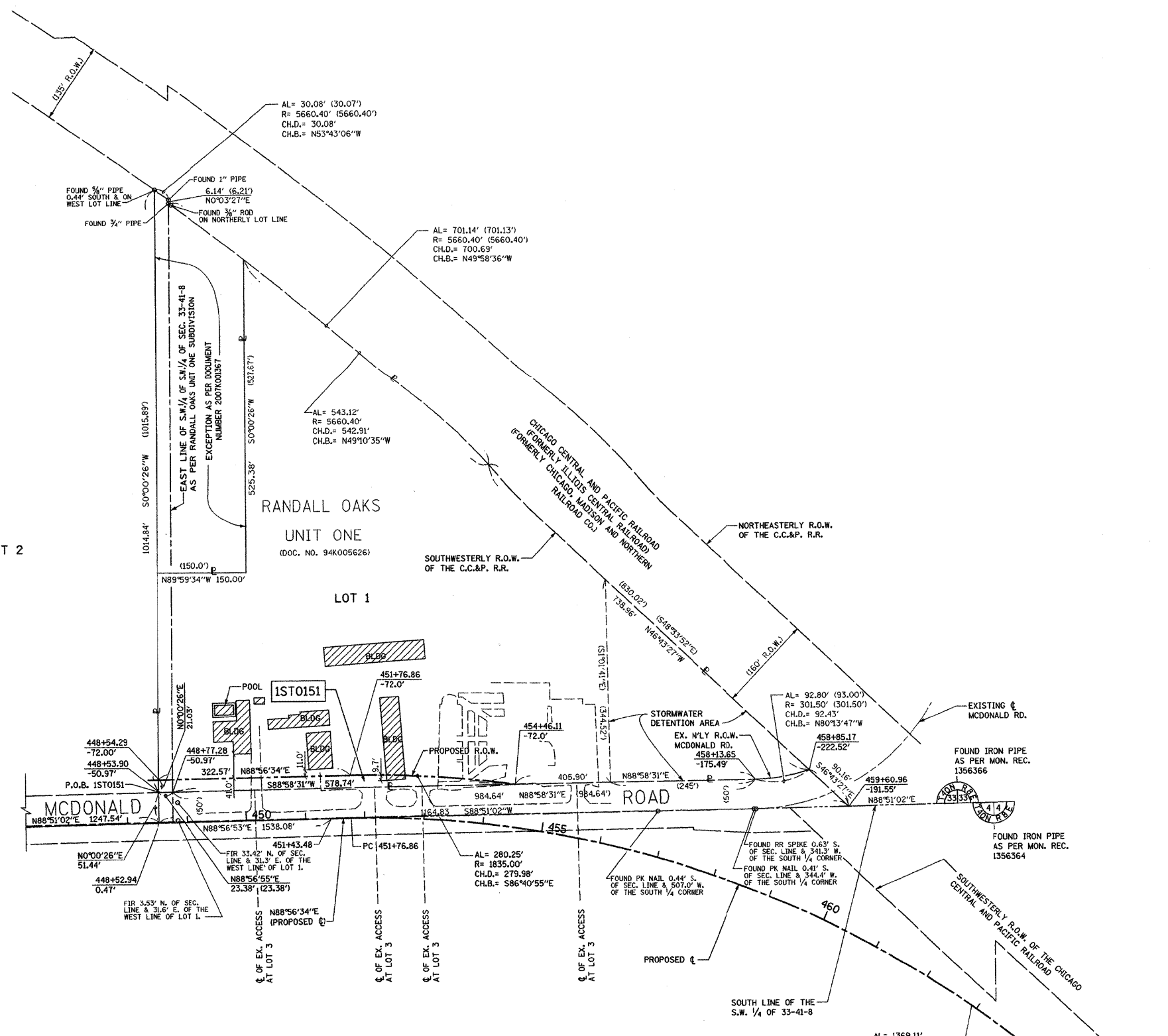

- ALL STATIONS HEREON REFERENCED ARE TO THE PROPOSED CENTERLINE STATIONING.
- SUBJECT TO EASEMENTS, IF ANY, AS PER DOCUMENT NUMBER 94K005626.
- EXISTING MCDONALD ROAD RIGHT OF WAY AS PER DOCUMENT NUMBER 94K005626.
- BASIS OF BEARINGS: ALL BEARINGS DEPICTED AS MEASURED HEREON ARE REFERENCED TO THE ILLINOIS STATE PLANE COORDINATE SYSTEM.

PARCEL NUMBER	OWNER	TOTAL HOLDINGS ACRES	AREA TAKEN ACRES	PREVIOUS DEDICATION ACRES	AREA REMAINING ACRES	AREA OF EASEMENT ACRES	PURPOSE OF EASEMENT	PERMANENT INDEX NUMBER	PROPERTY ACQUIRED BY
1ST0151	MCDONALD ROAD PARTNERS, LLC.	11.385	0.247	0.000	11.138	NA	N/A	06-33-351-002	

REVISION	DATE	DESCRIPTION
1-25-07		TOPO.
4-09-07		IDOT COM.
12-19-07		EXCEPTION

PLAT OF HIGHWAYS
STATE OF ILLINOIS
DEPARTMENT OF TRANSPORTATION
Stearns Rd. (Fox River Bridges)
SECTION 98-00214-02-BR KANE COUNTY
PROJECT JOB NO. R-91-083-01
STATION 448+53.90 TO STATION 454+46.11
SCALE: 1"= 100' SHEET 1 OF 1
BUREAU OF LAND ACQUISITION
201 WEST CENTER COURT
SCHAUMBURG, ILLINOIS 60196

THAT PART OF THE NW 1/4 OF SECTION 4, TOWNSHIP 40 N, RANGE 8 E OF THE 3RD P.M. &
 THAT PART OF THE S 1/2 OF SECTION 33, TOWNSHIP 41N, RANGE 8 E OF THE 3RD P.M., KANE COUNTY, ILLINOIS

CONTRACT NO.	TOTAL SHEETS	SHEET NO.
63076	220	83

- LEGEND
- RESET PIPE OR ROD TO ORIGINAL POSITION.
 - T1(B1) THESE STAKES REFERENCE FOUND OR SET MONUMENTATION.
T2(B2) SET 5/8 INCH IRON ROD TO THE FOUND IRON STAKE IDENTIFIED BY
T3(B3) COLORED PLASTIC CAP BEARING SURVEYORS REGISTRATION NUMBER.
 - T1 DENOTES TIE POINT NO. 1 SET IRON ROD FLUSH WITH GROUND SURFACE.
 - (B1) DENOTES TIE POINT NO. 1 SET IRON ROD 20" BELOW GROUND SURFACE.
 - DIVISION OF HIGHWAYS RIGHT OF WAY SURVEY MARKER PROPOSED TO BE SET.
 - STAKING OF PROPOSED RIGHT OF WAY. SET DIVISION OF HIGHWAYS SURVEY MARKER TO MONUMENT THE POSITION SHOWN IDENTIFIED BY INSCRIPTION DATA AND SURVEYORS REGISTRATION NUMBER.
 - PERMANENT SURVEY MARKER, I.D.O.T. STANDARD 235 (TO BE SET BY OTHERS)

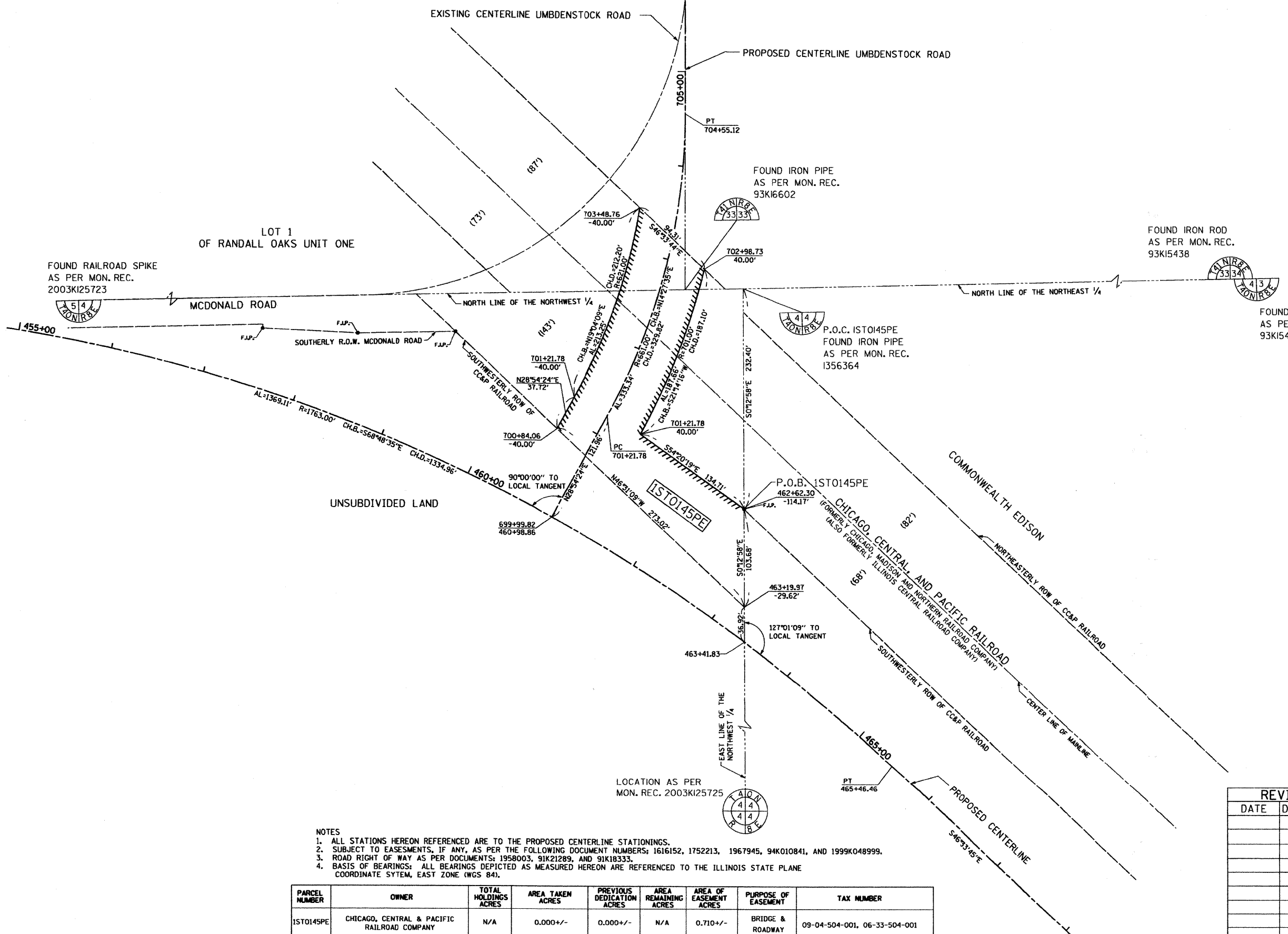
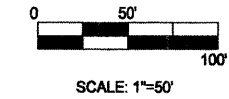
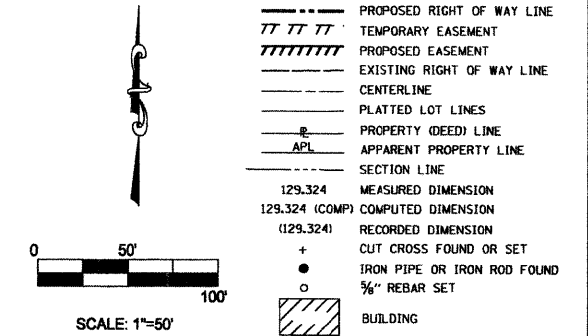

- NOTES
- ALL STATIONS HEREON REFERENCED ARE TO THE PROPOSED CENTERLINE STATIONINGS.
 - SUBJECT TO EASEMENTS, IF ANY, AS PER THE FOLLOWING DOCUMENT NUMBERS; 1616152, 1752213, 1967945, 94K010841, AND 1999K048999.
 - ROAD RIGHT OF WAY AS PER DOCUMENTS: 1958003, 91K21289, AND 91K18333.
 - BASIS OF BEARINGS: ALL BEARINGS DEPICTED AS MEASURED HEREON ARE REFERENCED TO THE ILLINOIS STATE PLANE COORDINATE SYSTEM, EAST ZONE (WGS 84).

PARCEL NUMBER	OWNER	TOTAL HOLDINGS ACRES	AREA TAKEN ACRES	PREVIOUS DEDICATION ACRES	AREA REMAINING ACRES	AREA OF EASEMENT ACRES	PURPOSE OF EASEMENT	TAX NUMBER
IST0145PE	CHICAGO, CENTRAL & PACIFIC RAILROAD COMPANY	N/A	0.000+/-	0.000+/-	N/A	0.710+/-	BRIDGE & ROADWAY	09-04-504-001, 06-33-504-001

COUNTY OF COOK:
 STATE OF ILLINOIS:

THIS PROFESSIONAL SERVICE CONFORMS TO THE CURRENT ILLINOIS MINIMUM STANDARDS OF THE PRACTICE OF LAND SURVEYING.

DECEMBER 6, 2005 RONALD W. SODERQUIST

Ronald W. Soderquist
 ILLINOIS PROFESSIONAL LAND SURVEYOR NO. 2722



benesch alfred benesch & company
 Engineers • Surveyors • Planners
 205 North Michigan Avenue, Suite 2400
 Chicago, Illinois 60601
 312-565-0450

REVISION	
DATE	DESCRIPTION

PLAT OF HIGHWAYS
 STATE OF ILLINOIS
 DEPARTMENT OF TRANSPORTATION
 Stearns Rd. (Fox River Bridges)

SECTION 98-00214-02-BR KANE COUNTY
 PROJECT JOB NO. R-91-083-01
 STATION TO STATION
 SCALE: 1"=50' SHEET OF

BUREAU OF LAND ACQUISITION
 201 WEST CENTER COURT
 SCHAUMBURG, ILLINOIS 60196

THAT PART OF THE S 1/2 OF SECTION 33, TOWNSHIP 41N, RANGE 8 E OF THE 3RD P.M., KANE COUNTY, ILLINOIS

CONTRACT NO.	TOTAL SHEETS	SHEET NO.
63076	220	84

LEGEND

- RESET PIPE OR ROD TO ORIGINAL POSITION.
- T1(B1) THESE STAKES REFERENCE FOUND OR SET MONUMENTATION.
T2(B2) SET 1/8 INCH IRON ROD TO TIE FOUND IRON STAKE IDENTIFIED BY
T3(B3) COLORED PLASTIC CAP BEARING SURVEYORS REGISTRATION NUMBER.
- T1 DENOTES TIE POINT NO. 1 SET IRON ROD FLUSH WITH GROUND SURFACE.
- (B1) DENOTES TIE POINT NO. 1 SET IRON ROD 20" BELOW GROUND SURFACE.
- DIVISION OF HIGHWAYS RIGHT OF WAY SURVEY MARKER PROPOSED TO BE SET.
- STAKING OF PROPOSED RIGHT OF WAY. SET DIVISION OF HIGHWAYS SURVEY MARKER TO MONUMENT THE POSITION SHOWN IDENTIFIED BY INSCRIPTION DATA AND SURVEYORS REGISTRATION NUMBER.
- ⊙ PERMANENT SURVEY MARKER, I.D.O.T. STANDARD 2135 (TO BE SET BY OTHERS)

SCALE: 1"=20'

- PROPOSED RIGHT OF WAY LINE
- TEMPORARY EASEMENT
- PROPOSED EASEMENT
- EXISTING RIGHT OF WAY LINE
- CENTERLINE
- PLATTED LOT LINES
- PROPERTY (DEED) LINE
- APPARENT PROPERTY LINE
- SECTION LINE
- 129.324 MEASURED DIMENSION
- 129.324 (COMP) COMPUTED DIMENSION
- (129.324) RECORDED DIMENSION
- + CUT CROSS FOUND OR SET
- IRON PIPE OR IRON ROD FOUND
- 1/2" REBAR SET
- ▨ BUILDING

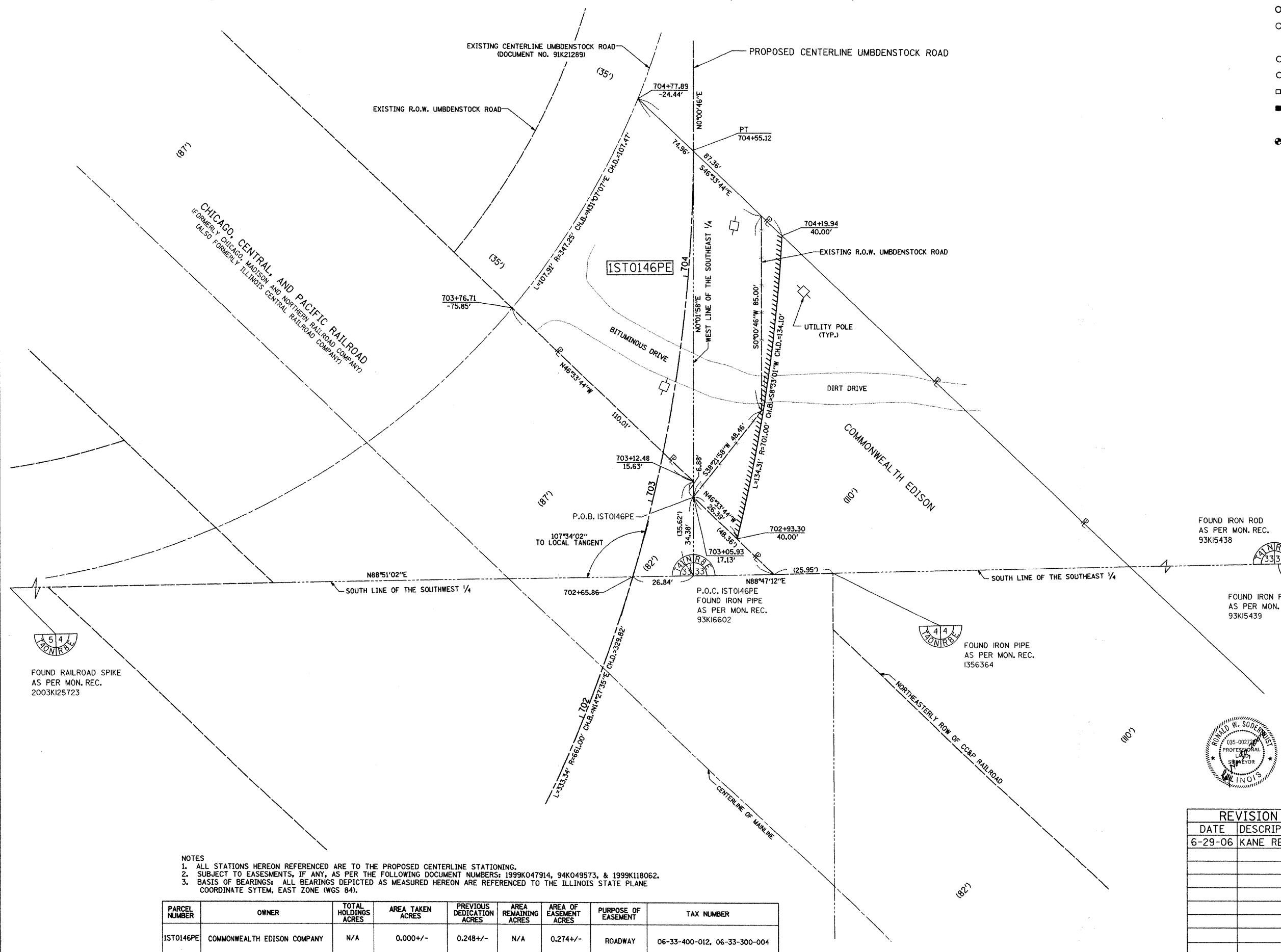

- NOTES
1. ALL STATIONS HEREON REFERENCED ARE TO THE PROPOSED CENTERLINE STATIONING.
 2. SUBJECT TO EASEMENTS, IF ANY, AS PER THE FOLLOWING DOCUMENT NUMBERS: 1999K047914, 94K049573, & 1999K118062.
 3. BASIS OF BEARINGS: ALL BEARINGS DEPICTED AS MEASURED HEREON ARE REFERENCED TO THE ILLINOIS STATE PLANE COORDINATE SYSTEM, EAST ZONE (WGS 84).

PARCEL NUMBER	OWNER	TOTAL HOLDINGS ACRES	AREA TAKEN ACRES	PREVIOUS DEDICATION ACRES	AREA REMAINING ACRES	AREA OF EASEMENT ACRES	PURPOSE OF EASEMENT	TAX NUMBER
IST0146PE	COMMONWEALTH EDISON COMPANY	N/A	0.000+/-	0.248+/-	N/A	0.274+/-	ROADWAY	06-33-400-012, 06-33-300-004

COUNTY OF COOK,
STATE OF ILLINOIS:

THIS PROFESSIONAL SERVICE CONFORMS TO THE CURRENT ILLINOIS MINIMUM STANDARDS OF THE PRACTICE OF LAND SURVEYING.

APRIL 10, 2006 RONALD W. SODERQUIST

Ronald W. Soderquist
ILLINOIS PROFESSIONAL LAND SURVEYOR NO. 2722



benesch alfred benesch & company
Engineers • Surveyors • Planners
205 North Michigan Avenue, Suite 2400
Chicago, Illinois 60601
312-665-0460

REVISION	
DATE	DESCRIPTION
6-29-06	KANE REV.

PLAT OF HIGHWAYS
STATE OF ILLINOIS
DEPARTMENT OF TRANSPORTATION
Stearns Rd. (Fox River Bridges)

SECTION 98-00214-02-BR KANE COUNTY
PROJECT JOB NO. R-91-083-01
STATION TO STATION
SCALE: 1"=20' SHEET 1 OF 1

BUREAU OF LAND ACQUISITION
201 WEST CENTER COURT
SCHAUMBURG, ILLINOIS 60196

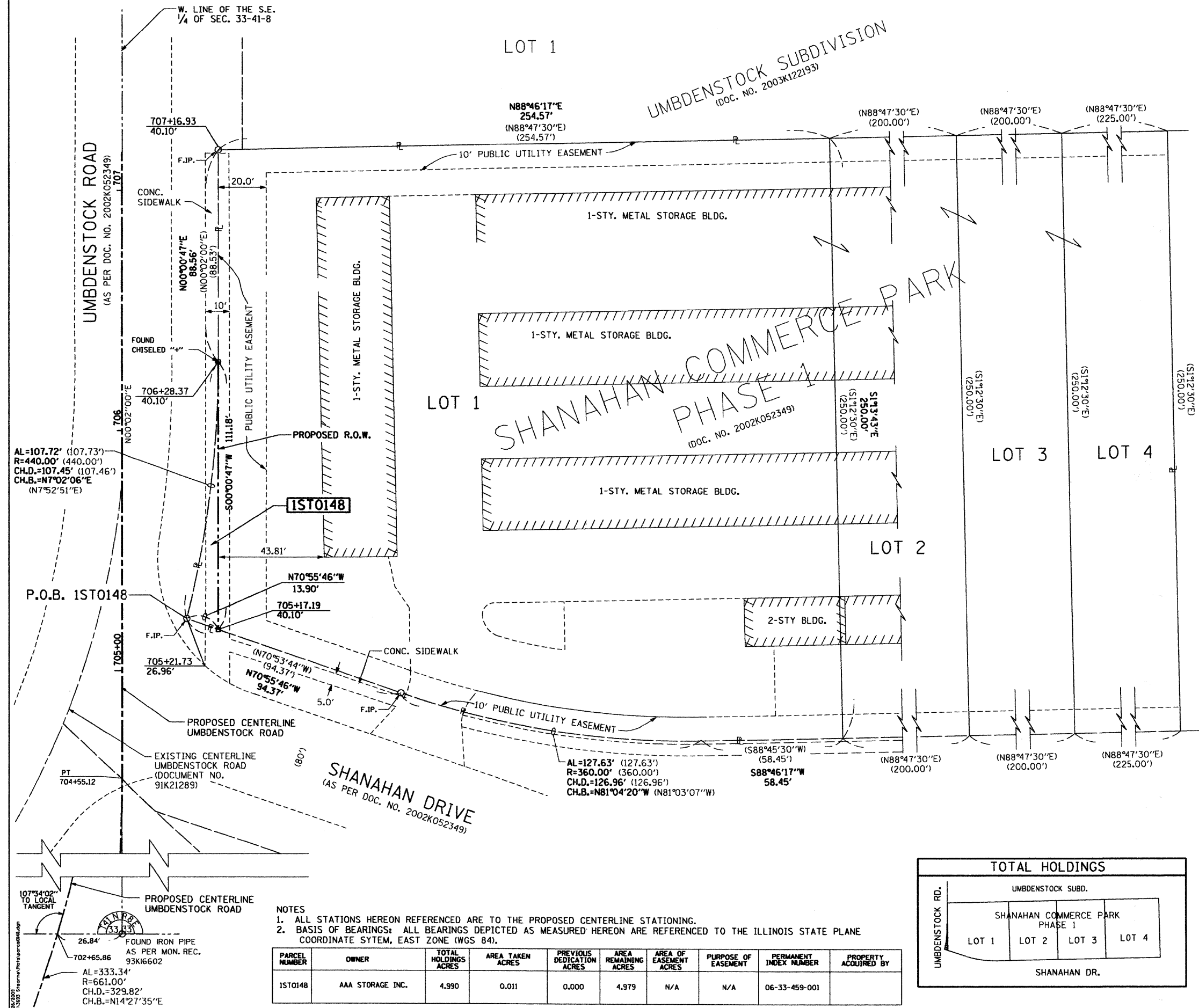

LEGEND

SECTION CORNER 9/10 11/12 QUARTER SECTION CORNER 15-16

SECTION LINE
QUARTER SECTION LINE
QUARTER, QUARTER SECTION LINE
PLATTED LOT LINE
PROPERTY (DEED) LINE

APL APPARENT PROPERTY LINE
EXISTING CENTER LINE
PROPOSED CENTER LINE
EXISTING RIGHT OF WAY LINE
PROPOSED RIGHT OF WAY LINE
PROPOSED EASEMENT

120.32' MEASURED DIMENSION
129.32'(Comp.) COMPUTED DIMENSION
() RECORD DATA

EXISTING BUILDING

SCALE: 1"=20'

- Bearings are referenced to the Illinois State Plane Coordinate System, East Zone, NAD 1983.
- IRON PIPE OR ROD FOUND ⊕ "MAG" NAIL SET
 - + CUT CROSS FOUND OR SET • 5/8" REBAR SET
 - T1 THESE STAKES REFERENCE FOUND OR SET MONUMENTATION. SET 5/8 INCH IRON ROD FLUSH WITH GROUND TO TIE FOUND IRON STAKE. IDENTIFIED BY COLORED PLASTIC CAP BEARING SURVEYORS REGISTRATION NUMBER.
 - BT1 BT2 BT3 THESE STAKES IN CULTIVATED AREAS, REFERENCE FOUND OR SET MONUMENTATION. BURIED 5/8 INCH IRON ROD 20 INCHES BELOW GROUND TO THE FOUND IRON STAKE, IDENTIFIED BY COLORED PLASTIC CAP BEARING SURVEYORS REGISTRATION NUMBER.
 - STAKING OF PROPOSED RIGHT OF WAY, SET DIVISION OF HIGHWAYS SURVEY MARKER TO MONUMENT THE POSITION SHOWN. IDENTIFIED BY INSCRIPTION DATA AND SURVEYORS REGISTRATION NUMBER.
 - M STAKING OF PROPOSED RIGHT OF WAY IN CULTIVATED AREAS. BURIED 5/8 INCH METAL ROD 20 INCHES BELOW GROUND TO MARK FUTURE SURVEY MARKER POSITION IDENTIFIED BY COLORED PLASTIC CAP BEARING SURVEYORS REGISTRATION NUMBER.
 - ⊕ PERMANENT SURVEY MARKER, I.D.O.T. STD 2135 (TO BE SET BY OTHERS)
 - RIGHT OF WAY STAKING PROPOSED TO BE SET.

COUNTY OF COOK:
STATE OF ILLINOIS:

THIS IS TO CERTIFY THAT I, RONALD W. SODERQUIST, AN ILLINOIS PROFESSIONAL LAND SURVEYOR, NUMBER 2722, HAVE SURVEYED THE PLAT OF HIGHWAYS SHOWN HEREON IN SECTION 33, TOWNSHIP 41 N., RANGE 8 E., OF THE THIRD PRINCIPAL MERIDIAN, KANE COUNTY, THAT THE SURVEY IS TRUE AND COMPLETE AS SHOWN TO THE BEST OF MY KNOWLEDGE AND BELIEF, THAT THE PLAT CORRECTLY REPRESENTS SAID SURVEY, THAT ALL MONUMENTS FOUND AND ESTABLISHED ARE OF PERMANENT QUALITY AND OCCUPY THE POSITIONS SHOWN THEREON AND THAT THE MONUMENTS ARE SUFFICIENT TO ENABLE THE SURVEY TO BE RETRACED.

FEBRUARY 9, 2007
RONALD W. SODERQUIST
ILLINOIS PROFESSIONAL LAND SURVEYOR NO. 2722
LICENSE EXPIRATION DATE: NOVEMBER 30, 2010



benesch
alfred benesch & company
Engineers • Surveyors • Planners
205 North Michigan Avenue, Suite 2400
Chicago, Illinois 60601
312-666-0460
Design Firm License # 184.000882

NOTES
1. ALL STATIONS HEREON REFERENCED ARE TO THE PROPOSED CENTERLINE STATIONING.
2. BASIS OF BEARINGS: ALL BEARINGS DEPICTED AS MEASURED HEREON ARE REFERENCED TO THE ILLINOIS STATE PLANE COORDINATE SYSTEM, EAST ZONE (WGS 84).

PARCEL NUMBER	OWNER	TOTAL HOLDINGS ACRES	AREA TAKEN ACRES	PREVIOUS DEDICATION ACRES	AREA REMAINING ACRES	AREA OF EASEMENT ACRES	PURPOSE OF EASEMENT	PERMANENT INDEX NUMBER	PROPERTY ACQUIRED BY
1ST0148	AAA STORAGE INC.	4.990	0.011	0.000	4.979	N/A	N/A	06-33-459-001	

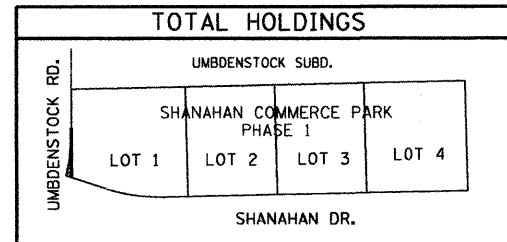

REVISION	
DATE	DESCRIPTION
2/21/07	KANE COM.
4/09/07	IDOT COM.

PLAT OF HIGHWAYS
STATE OF ILLINOIS
DEPARTMENT OF TRANSPORTATION
Stearns Rd. (Fox River Bridges)

SECTION 98-00214-02-BR KANE COUNTY
PROJECT JOB NO. R-91-083-01
STATION 705+17.19 TO STATION 706+28.37
SCALE: 1"=20' SHEET 1 OF 1

BUREAU OF LAND ACQUISITION
201 WEST CENTER COURT
SCHAUMBURG, ILLINOIS 60196

PART OF THE E 1/2 OF SECTION 4 & THE W 1/2 OF SECTION 3, TOWNSHIP 40 N, RANGE 8 E OF THE 3RD P.M., KANE COUNTY, ILLINOIS

CONTRACT NO.	TOTAL SHEETS	SHEET NO.
63076	220	86

PARCEL NUMBER	OWNER	TOTAL HOLDINGS ACRES	AREA TAKEN ACRES	PREVIOUS DEDICATION ACRES	AREA REMAINING ACRES	AREA OF EASEMENT ACRES	PURPOSE OF EASEMENT	PERMANENT INDEX NUMBER	PROPERTY ACQUIRED BY
1ST01200D			21.294	0.679	149.299	N/A	N/A	09-03-301-005, 09-03-301-012	
1ST01201E-1	FIRST AMERICAN BANK, TR.# 86-084	149.299	0.000	0.000	149.299	7.650	TEMP. CONST.	09-03-301-013, 09-03-100-016	
1ST01202E-2			0.000	0.000	149.299	0.201	DEMOLITION	09-04-200-005, 09-04-200-014	

*AREA OF DEDICATION

LEGEND

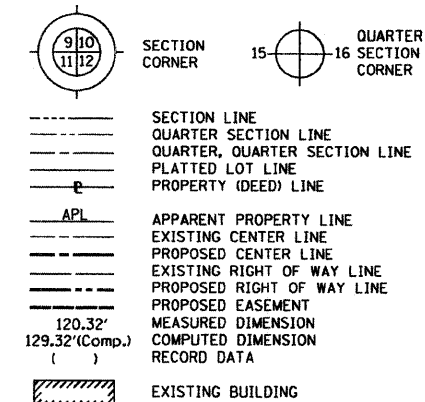

Bearings are referenced to the Illinois State Plane Coordinate System, East Zone, NAD 1983.

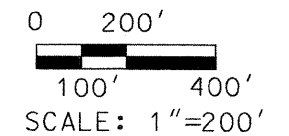

CURVE	RADIUS	ARC LENGTH	CHORD BEARING	CHORD DISTANCE
C1	42.00'	70.73'	S36°43'19"W	62.66'
C2	1141.00'	57.04'	S83°27'00"W	57.03'
C3	1681.00'	131.91'	N48°48'38"W	131.88'
C4	2952.83'	160.34'	S48°03'14"E	160.32'
C5	1651.00'	104.98'	N48°23'03"W	104.96'
C6	1245.85'	420.42'	N70°50'03"E	418.43'
C7	1275.85'	387.76'	S52°27'36"W	386.27'
C8	1763.00'	204.14'	S49°52'47"E	204.02'
C9	1145.92'	500.00'	N43°23'37"E	496.05'
C10	1317.12'	575.85'	N68°25'07"E	571.28'
C11	1100.00'	404.35'	S88°31'33"E	402.08'
C13	2822.00'	342.30'	N84°10'19"W	342.09'
C14	2832.00'	333.66'	N49°56'16"W	333.47'

SEGMENT	BEARING	DISTANCE
A-B	S43°41'39"W	40.18'
C-D	S5°02'01"E	2.76'
E-F	N9°29'53"W	30.40'
F-G	S80°30'07"W	60.50'
G-H	S9°29'53"E	27.00'
H-Q	S80°30'07"W	80.32'
L-K	S78°28'10"W	22.00'
P-M	S87°38'55"E	20.70'
M-N	S2°52'09"W	24.88'
N-O	S87°38'17"E	42.32'

POINT	STATION	OFFSET
A	804+41.13	14.75'
B	804+18.21	-18.25'
C	303+53.49	-22.09'
D	303+53.44	-19.33'
E	302+97.42	-20.25'
F	302+97.13	-50.65'
G	302+36.73	-50.18'
H	302+36.94	-23.19'
I	808+24.00	-86.00'
J	504+90.46	116.08'
K	808+08.20	-40.30'
L	808+08.21	-18.30'
M	811+38.13	-20.24'
N	811+14.04	-26.42'
O	811+03.89	14.67'
P	811+43.09	-40.34'
Q	301+56.62	-22.57'
R	801+93.00	-66.00'
S	504+91.00	96.00'
T	502+31.00	82.00'
U	502+30.46	102.00'
V	501+29.92	102.00'
W	501+29.92	82.00'

NOTES:
 - ALL STATIONS HEREON REFERENCED ARE TO THE PROPOSED CENTERLINE STATIONINGS.
 - UTILITY EASEMENT GRANTED TO ILLINOIS BELL TELEPHONE COMPANY LOCATED IN THE WESTERLY RIGHT OF WAY OF MCLEAN BOULEVARD PER DOCUMENT NO. 304978.
 - UTILITY EASEMENT GRANTED TO NORTHERN ILLINOIS GAS COMPANY LOCATED IN THE WESTERLY RIGHT OF WAY OF MCLEAN BOULEVARD PER DOCUMENT NO. 2005K020936.

- IRON PIPE OR ROD FOUND ⊕ "MAG" NAIL SET
- + CUT CROSS FOUND OR SET ● 5/8" REBAR SET
- T1 THESE STAKES REFERENCE FOUND OR SET MONUMENTATION. SET 5/8 INCH IRON ROD FLUSH WITH GROUND TO TIE FOUND IRON STAKE. IDENTIFIED BY COLORED PLASTIC CAP BEARING SURVEYORS REGISTRATION NUMBER.
- BT1 THESE STAKES IN CULTIVATED AREAS, REFERENCE FOUND OR SET MONUMENTATION. BURIED 5/8 INCH IRON ROD 20 INCHES BELOW GROUND TO THE FOUND IRON STAKE. IDENTIFIED BY COLORED PLASTIC CAP BEARING SURVEYORS REGISTRATION NUMBER.
- STAKING OF PROPOSED RIGHT OF WAY, SET DIVISION OF HIGHWAYS SURVEY MARKER TO MONUMENT THE POSITION SHOWN. IDENTIFIED BY INSCRIPTION DATA AND SURVEYORS REGISTRATION NUMBER.
- M STAKING OF PROPOSED RIGHT OF WAY IN CULTIVATED AREAS. BURIED 5/8 INCH IRON ROD 20 INCHES BELOW GROUND TO MARK FUTURE SURVEY MARKER POSITION IDENTIFIED BY COLORED PLASTIC CAP BEARING SURVEYORS REGISTRATION NUMBER.
- PERMANENT SURVEY MARKER, I.D.O.T. STD 2135 (TO BE SET BY OTHERS)
- RIGHT OF WAY STAKING PROPOSED TO BE SET.

COUNTY OF COOK;
 STATE OF ILLINOIS;
 THIS IS TO CERTIFY THAT I, RONALD W. SODERQUIST, AN ILLINOIS PROFESSIONAL LAND SURVEYOR, NUMBER 2722, HAVE SURVEYED THE PLAT OF HIGHWAYS SHOWN HEREON IN SECTION 304, TOWNSHIP 40 N., RANGE 8E., OF THE THIRD PRINCIPAL MERIDIAN, KANE COUNTY, THAT THE SURVEY IS TRUE AND COMPLETE AS SHOWN TO THE BEST OF MY KNOWLEDGE AND BELIEF, THAT THE PLAT CORRECTLY REPRESENTS SAID SURVEY, THAT ALL MONUMENTS FOUND AND ESTABLISHED ARE OF PERMANENT QUALITY AND OCCUPY THE POSITIONS SHOWN THEREON AND THAT THE MONUMENTS ARE SUFFICIENT TO ENABLE THE SURVEY TO BE RETRACED.
 AUGUST 19, 2005
 RONALD W. SODERQUIST
 ILLINOIS PROFESSIONAL LAND SURVEYOR NO. 2722
 LICENSE EXPIRATION DATE: NOVEMBER 30, 2010



benesch
 Engineers • Surveyors • Planners
 205 North Michigan Avenue, Suite 2400
 Chicago, Illinois 60601
 312-565-0450
 Design Firm License # 184.000882

REVISION	
DATE	DESCRIPTION
9-02-05	KANE CO.
9-08-05	PAR#
9-06-06	COUNTY
5-14-08	EASE./TAKE PROJECT

PLAT OF HIGHWAYS
 STATE OF ILLINOIS
 DEPARTMENT OF TRANSPORTATION
 Stearns Rd. (Fox River Bridges)
 SECTION 98-00214-02-BR KANE COUNTY
 JOB NO. R-91-083-01
 STATION 462+62.30 TO STATION 511+94.35
 SCALE: 1"=200'
 SHEET 1 OF 1
 BUREAU OF LAND ACQUISITION
 201 WEST CENTER COURT
 SCHAMBURG, ILLINOIS 60196

PART OF THE NW 1/4 OF SECTION 3 AND THE NE 1/4 OF SECTION 4, TOWNSHIP 40 N,
RANGE 8 E OF THE 3RD P.M., KANE COUNTY, ILLINOIS

CONTRACT NO.	TOTAL SHEETS	SHEET NO.
63076	220	87

LEGEND

- IRON PIPE OR ROD FOUND ⊕ "MAG" NAIL SET
- + CUT CROSS FOUND OR SET • 5/8" REBAR SET
- T1 THESE STAKES REFERENCE FOUND OR SET MONUMENTATION. SET 5/8 INCH IRON ROD FLUSH WITH GROUND TO TIE FOUND IRON STAKE. IDENTIFIED BY COLORED PLASTIC CAP BEARING SURVEYORS REGISTRATION NUMBER.
- BT1 THESE STAKES IN CULTIVATED AREAS, REFERENCE FOUND OR SET MONUMENTATION. BURIED 5/8 INCH IRON ROD 20 INCHES BELOW GROUND TO THE FOUND IRON STAKE. IDENTIFIED BY COLORED PLASTIC CAP BEARING SURVEYORS REGISTRATION NUMBER.
- STAKING OF PROPOSED RIGHT OF WAY, SET DIVISION OF HIGHWAYS SURVEY MARKER TO MONUMENT THE POSITION SHOWN. IDENTIFIED BY INSCRIPTION DATA AND SURVEYORS REGISTRATION NUMBER.
- M STAKING OF PROPOSED RIGHT OF WAY IN CULTIVATED AREAS. BURIED 5/8 INCH METAL ROD 20 INCHES BELOW GROUND TO MARK FUTURE SURVEY MARKER POSITION IDENTIFIED BY COLORED PLASTIC CAP BEARING SURVEYORS REGISTRATION NUMBER.
- ⊕ PERMANENT SURVEY MARKER, I.D.O.T. STD 2135 (TO BE SET BY OTHERS)
- RIGHT OF WAY STAKING PROPOSED TO BE SET.

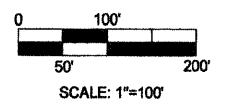
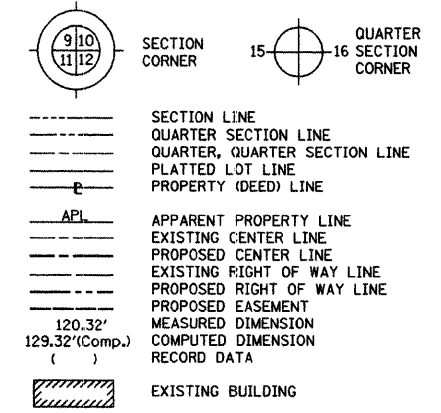

Bearings are referenced to the Illinois State Plane Coordinate System, East Zone, NAD 1983.

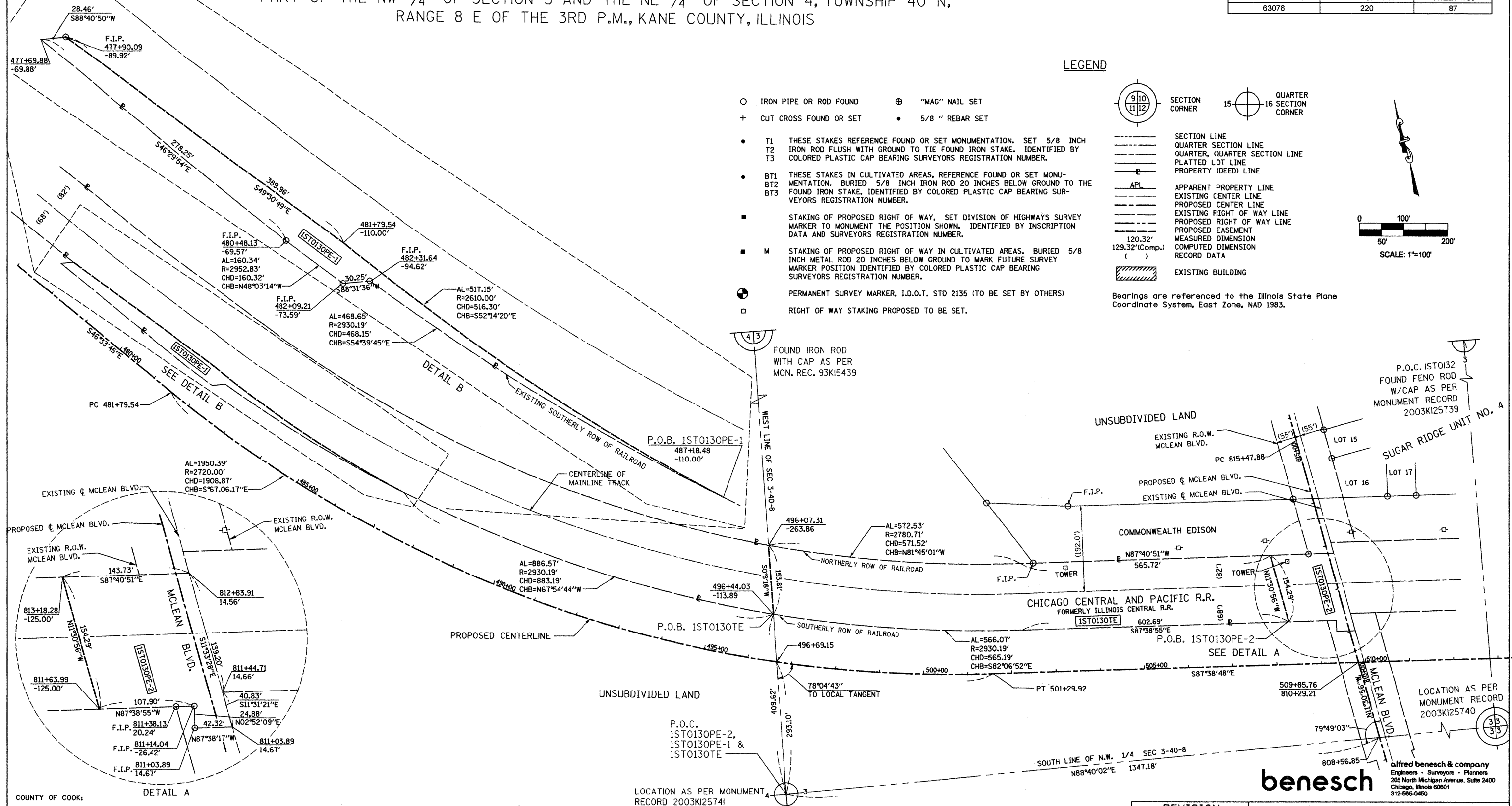

COUNTY OF COOK
STATE OF ILLINOIS

THIS IS TO CERTIFY THAT I, RONALD W. SODERQUIST, AN ILLINOIS PROFESSIONAL LAND SURVEYOR, NUMBER 2722, HAVE SURVEYED THE PLAT OF HIGHWAYS SHOWN HEREON IN SECTIONS 3 & 4, TOWNSHIP 40 N., RANGE 8 E., OF THE THIRD PRINCIPAL MERIDIAN, KANE COUNTY, THAT THE SURVEY IS TRUE AND COMPLETE AS SHOWN TO THE BEST OF MY KNOWLEDGE AND BELIEF, THAT THE PLAT CORRECTLY REPRESENTS SAID SURVEY, THAT ALL MONUMENTS FOUND AND ESTABLISHED ARE OF PERMANENT QUALITY AND OCCUPY THE POSITIONS SHOWN THEREON AND THAT THE MONUMENTS ARE SUFFICIENT TO ENABLE THE SURVEY TO BE RETRACED.

NOVEMBER 30, 2005

RONALD W. SODERQUIST



- NOTES:
- 1) ALL STATIONS HEREON REFERENCED ARE TO THE PROPOSED CENTERLINE STATIONINGS.
 - 2) SUBJECT TO EASEMENTS, IF ANY, AS PER THE FOLLOWING DOCUMENT NUMBERS: 1616152, 1615651, 1752213, 1967945, 94K010841, 9749, 788125.
 - 3) ROAD RIGHT OF WAY AS PER DOCUMENTS 360839 AND 360841.
 - 4) BASIS OF BEARINGS: ALL BEARINGS DEPICTED AS MEASURED HEREON ARE REFERENCED TO THE ILLINOIS STATE PLANE COORDINATE SYSTEM, EAST ZONE (NAD 83).

PARCEL NUMBER	OWNER	TOTAL HOLDINGS ACRES	AREA TAKEN ACRES	PREVIOUS DEDICATION ACRES	AREA REMAINING ACRES	AREA OF EASEMENT ACRES	PURPOSE OF EASEMENT	PERMANENT INDEX NUMBER	PROPERTY ACQUIRED BY
1ST0130PE-2	CHICAGO, CENTRAL AND PACIFIC R.R.	NA	0.000	NA	NA	0.517	BRIDGE	09-03-504-005 09-04-504-002	
1ST0130PE-1						0.385	GRADING		
1ST0130TE						3.960	MAINT. OF RAIL TRAFFIC		

REVISION	
DATE	DESCRIPTION
12/21/05	KANE COM.
7-11-07	IDOT COM.

benesch
Engineers - Surveyors - Planners
205 North Michigan Avenue, Suite 2400
Chicago, Illinois 60601
312-566-0460



PLAT OF HIGHWAYS
STATE OF ILLINOIS
DEPARTMENT OF TRANSPORTATION
Stearns Rd. (Fox River Bridges)

SECTION 98-00214-02-BR KANE COUNTY
PROJECT JOB NO. R-91-083-01
STATION 477+69.88 TO STATION 811+03.89
SCALE: 1" = 100' SHEET 1 OF 1

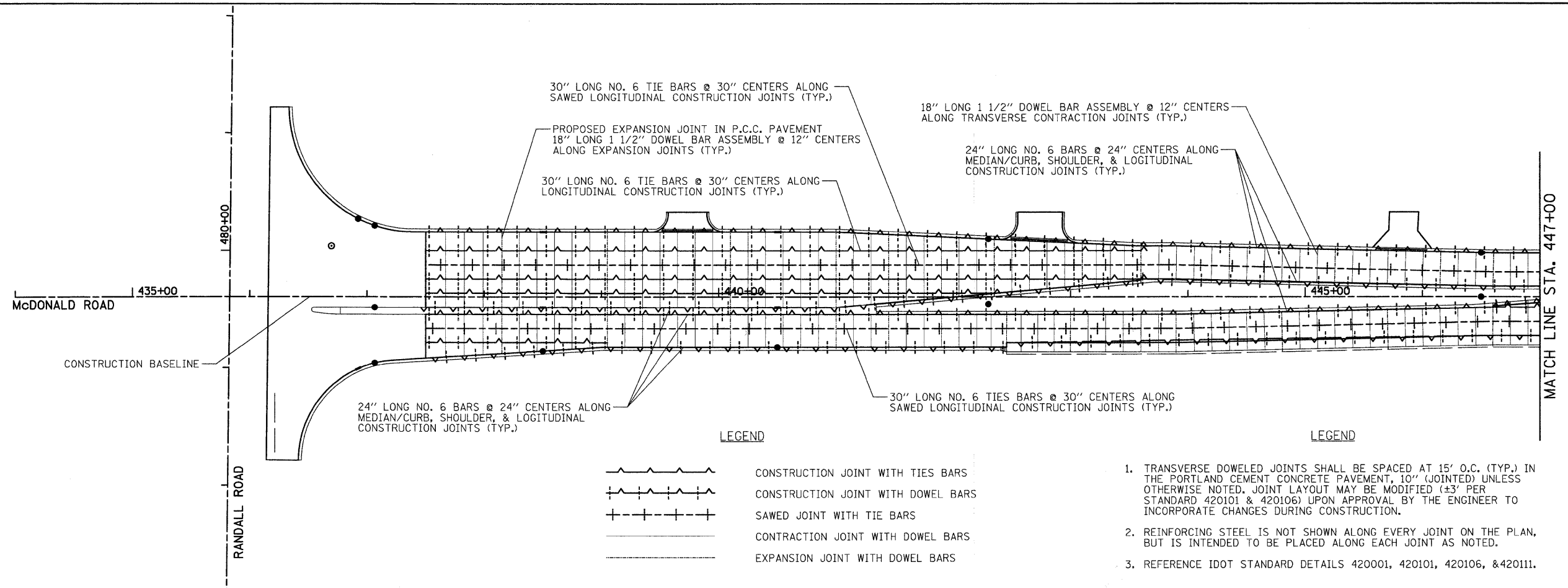
BUREAU OF LAND ACQUISITION
201 WEST CENTER COURT
SCHAUMBURG, ILLINOIS 60196

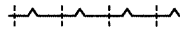
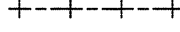

LEGEND

-  CONSTRUCTION JOINT WITH TIES BARS
-  CONSTRUCTION JOINT WITH DOWEL BARS
-  SAWED JOINT WITH TIE BARS
-  CONTRACTION JOINT WITH DOWEL BARS
-  EXPANSION JOINT WITH DOWEL BARS

1. TRANSVERSE DOWELED JOINTS SHALL BE SPACED AT 15' O.C. (TYP.) IN THE PORTLAND CEMENT CONCRETE PAVEMENT, 10" (JOINTED) UNLESS OTHERWISE NOTED. JOINT LAYOUT MAY BE MODIFIED (±3' PER STANDARD 420101 & 420106) UPON APPROVAL BY THE ENGINEER TO INCORPORATE CHANGES DURING CONSTRUCTION.
2. REINFORCING STEEL IS NOT SHOWN ALONG EVERY JOINT ON THE PLAN, BUT IS INTENDED TO BE PLACED ALONG EACH JOINT AS NOTED.
3. REFERENCE IDOT STANDARD DETAILS 420001, 420101, 420106, & 420111.

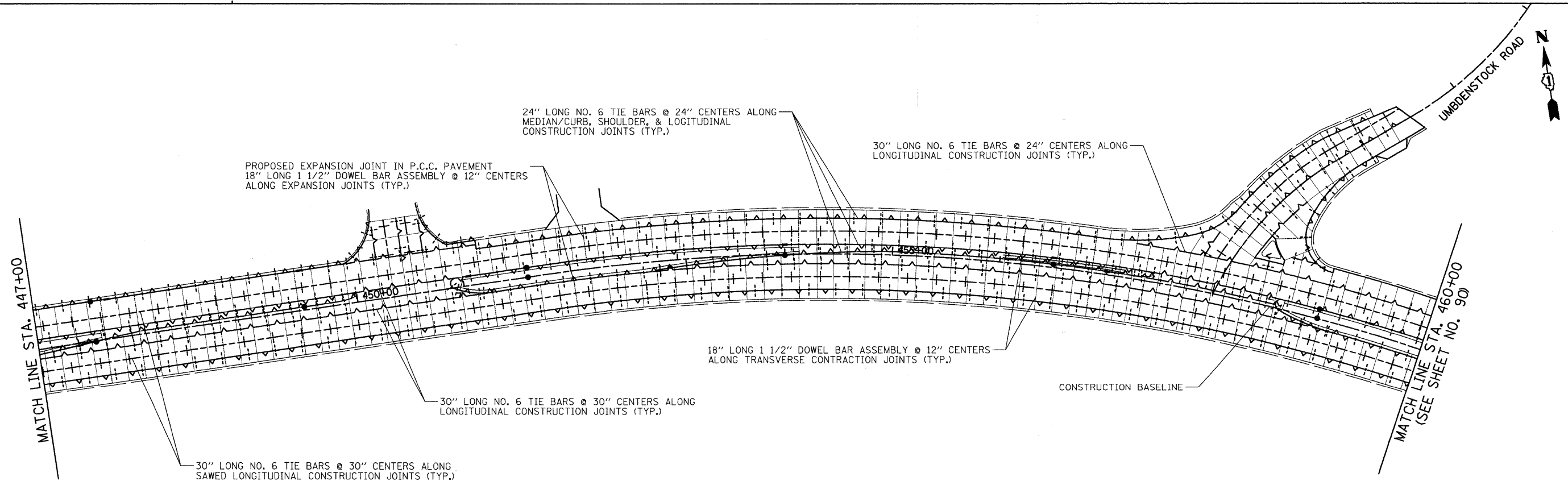

	USER NAME = ead	DESIGNED - JSM	REVISED -	KANE COUNTY DIVISION OF TRANSPORTATION	PAVEMENT JOINTING PLAN - STEARNS ROAD	F.A. RTE.	SECTION	COUNTY	TOTAL SHEETS	SHEET NO.
	PLOT SCALE = 50.0000' / IN.	DRAWN - JSM	REVISED -			361	06-00214-25-BR	KANE	220	89
	PLOT DATE = 3/27/2009	CHECKED - BJC	REVISED -			CONTRACT NO. 63076				
DATE - 3/30/09				REVISED -	SCALE: 1" = 50'	SHEET NO. 1 OF 3 SHEETS		STA. 437+50 TO STA. 460+00		FED. ROAD DIST. NO. 1 [ILLINOIS] FED. AID PROJECT

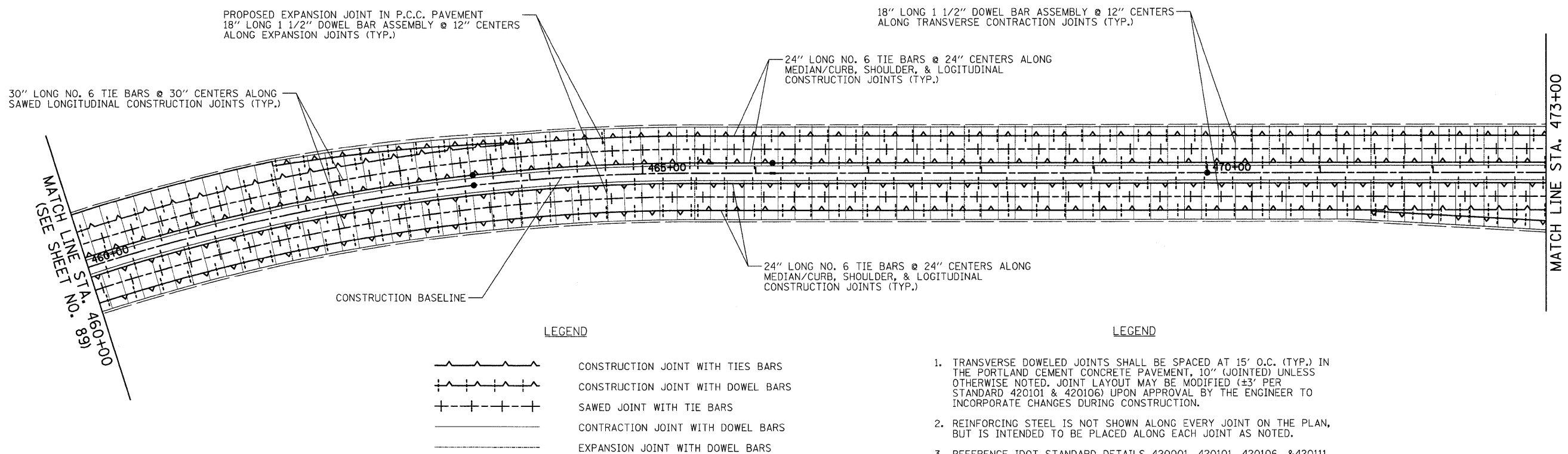
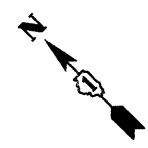

LEGEND

	CONSTRUCTION JOINT WITH TIES BARS
	CONSTRUCTION JOINT WITH DOWEL BARS
	SAWED JOINT WITH TIE BARS
	CONTRACTION JOINT WITH DOWEL BARS
	EXPANSION JOINT WITH DOWEL BARS

- LEGEND**
1. TRANSVERSE DOWELED JOINTS SHALL BE SPACED AT 15' O.C. (TYP.) IN THE PORTLAND CEMENT CONCRETE PAVEMENT, 10" (JOINTED) UNLESS OTHERWISE NOTED. JOINT LAYOUT MAY BE MODIFIED (±3' PER STANDARD 420101 & 420106) UPON APPROVAL BY THE ENGINEER TO INCORPORATE CHANGES DURING CONSTRUCTION.
 2. REINFORCING STEEL IS NOT SHOWN ALONG EVERY JOINT ON THE PLAN, BUT IS INTENDED TO BE PLACED ALONG EACH JOINT AS NOTED.
 3. REFERENCE IDOT STANDARD DETAILS 420001, 420101, 420106, & 420111.

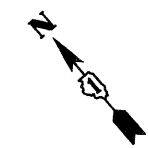
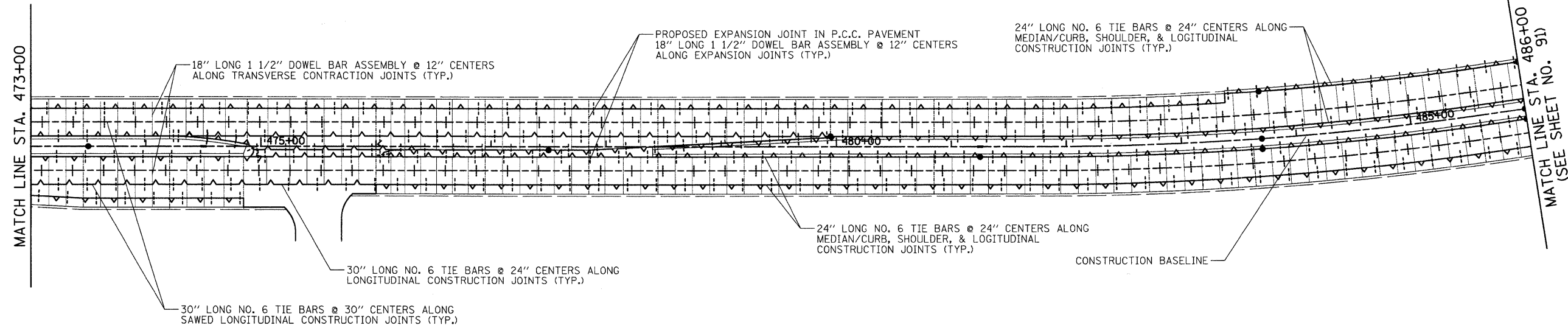

	USER NAME = ead	DESIGNED - JSM	REVISED -	KANE COUNTY DIVISION OF TRANSPORTATION	PAVEMENT JOINTING PLAN - STEARNS ROAD	F.A. RTE. 361	SECTION 06-00214-25-BR	COUNTY KANE	TOTAL SHEETS 220	SHEET NO. 90	
	PLOT SCALE = 50.0000' / IN.	CHECKED - BJC	REVISED -			CONTRACT NO. 63076					
	PLOT DATE = 3/27/2009	DATE - 3/30/09	REVISED -			SCALE: 1" = 50' SHEET NO. 2 OF 3 SHEETS STA. 460+00 TO STA. 486+00 FED. ROAD DIST. NO. 1 [ILLINOIS] FED. AID PROJECT					



MATCH LINE STA. 486+00
(SEE SHEET NO. 90)

MATCH LINE STA. 499+00

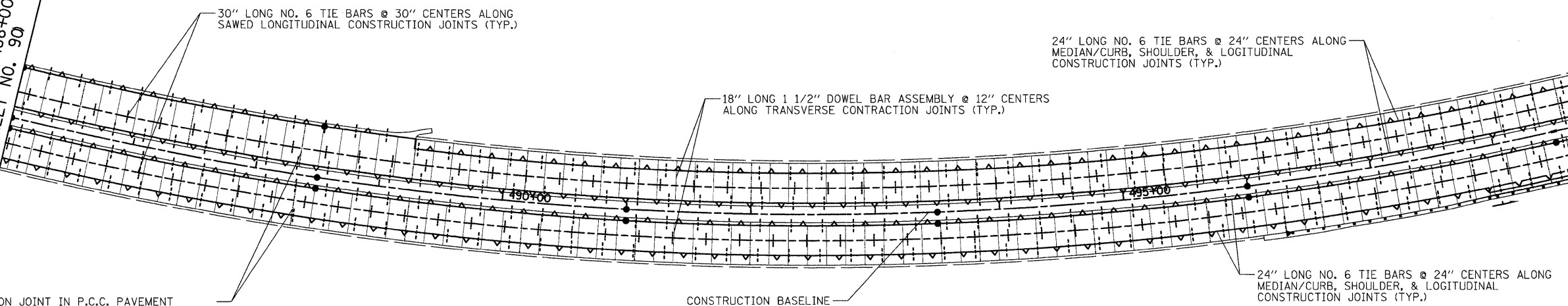

PROPOSED EXPANSION JOINT IN P.C.C. PAVEMENT
18" LONG 1 1/2" DOWEL BAR ASSEMBLY @ 12" CENTERS
ALONG EXPANSION JOINTS (TYP.)

LEGEND

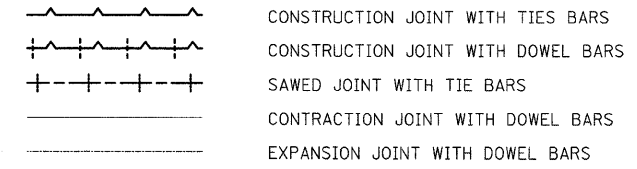

24" LONG NO. 6 TIE BARS @ 24" CENTERS ALONG
MEDIAN/CURB, SHOULDER, & LOGITUDINAL
CONSTRUCTION JOINTS (TYP.)

18" LONG 1 1/2" DOWEL BAR ASSEMBLY @ 12" CENTERS
ALONG TRANSVERSE CONTRACTION JOINTS (TYP.)

CONSTRUCTION BASELINE

24" LONG NO. 6 TIE BARS @ 24" CENTERS ALONG
MEDIAN/CURB, SHOULDER, & LOGITUDINAL
CONSTRUCTION JOINTS (TYP.)

LEGEND

1. TRANSVERSE DOWELED JOINTS SHALL BE SPACED AT 15' O.C. (TYP.) IN THE PORTLAND CEMENT CONCRETE PAVEMENT, 10' (JOINTED) UNLESS OTHERWISE NOTED. JOINT LAYOUT MAY BE MODIFIED (+/-3' PER STANDARD 420101 & 420106) UPON APPROVAL BY THE ENGINEER TO INCORPORATE CHANGES DURING CONSTRUCTION.
2. REINFORCING STEEL IS NOT SHOWN ALONG EVERY JOINT ON THE PLAN, BUT IS INTENDED TO BE PLACED ALONG EACH JOINT AS NOTED.
3. REFERENCE IDOT STANDARD DETAILS 420001, 420101, 420106, & 420111.

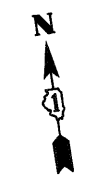

MATCH LINE STA. 499+00

MATCH LINE STATION 508+40
(SEE STAGE 2 CONTRACT)

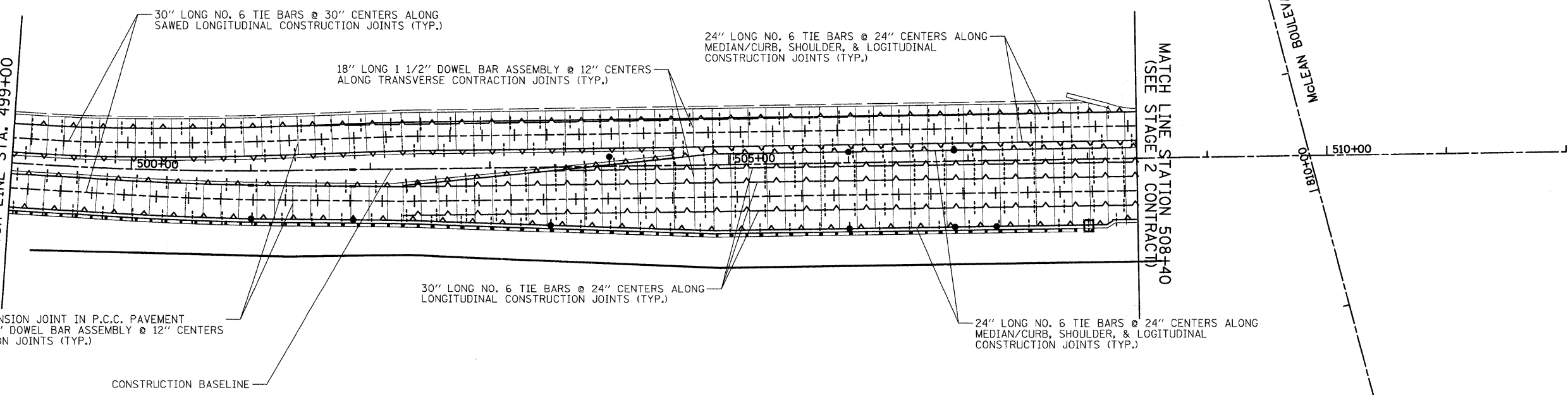

PROPOSED EXPANSION JOINT IN P.C.C. PAVEMENT
18" LONG 1 1/2" DOWEL BAR ASSEMBLY @ 12" CENTERS
ALONG EXPANSION JOINTS (TYP.)

CONSTRUCTION BASELINE

18" LONG 1 1/2" DOWEL BAR ASSEMBLY @ 12" CENTERS
ALONG TRANSVERSE CONTRACTION JOINTS (TYP.)

24" LONG NO. 6 TIE BARS @ 24" CENTERS ALONG
MEDIAN/CURB, SHOULDER, & LOGITUDINAL
CONSTRUCTION JOINTS (TYP.)

30" LONG NO. 6 TIE BARS @ 24" CENTERS ALONG
LONGITUDINAL CONSTRUCTION JOINTS (TYP.)

24" LONG NO. 6 TIE BARS @ 24" CENTERS ALONG
MEDIAN/CURB, SHOULDER, & LOGITUDINAL
CONSTRUCTION JOINTS (TYP.)

DRAPER AVENUE BOULEVARD
0+000

510+00

FILE NAME =	USER NAME = ead	DESIGNED - JSM	REVISED -	KANE COUNTY DIVISION OF TRANSPORTATION	PAVEMENT JOINTING PLAN - STEARNS ROAD	F.A. RTE. 361	SECTION 06-00214-25-BR	COUNTY KANE	TOTAL SHEETS 220	SHEET NO. 91	
	PLOT SCALE = 50.0000' / IN.	DRAWN - JSM	REVISED -			SCALE: 1" = 50' SHEET NO. 3 OF 3 SHEETS STA. 486+00 TO STA. 508+40					
	PLOT DATE = 3/27/2009	CHECKED - BJC	REVISED -			CONTRACT NO. 63076					
	DATE - 3/30/09	REVISED -	FED. ROAD DIST. NO. ILLINOIS FED. AID PROJECT								

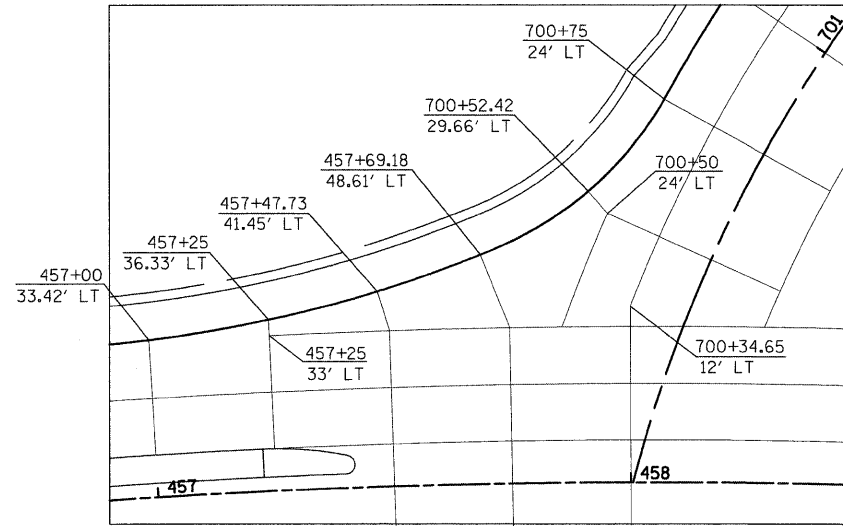

NOTE

1. ALL ELEVATIONS ARE SHOWN AT 25' INTERVALS UNLESS OTHERWISE NOTED.
2. GRADES SHOWN IN PARENTHESIS ARE EXISTING GRADES.
3. SEE DETAILS SHEET 137 FOR ISLAND DETAILS NOT SHOWN ON THIS SHEET.

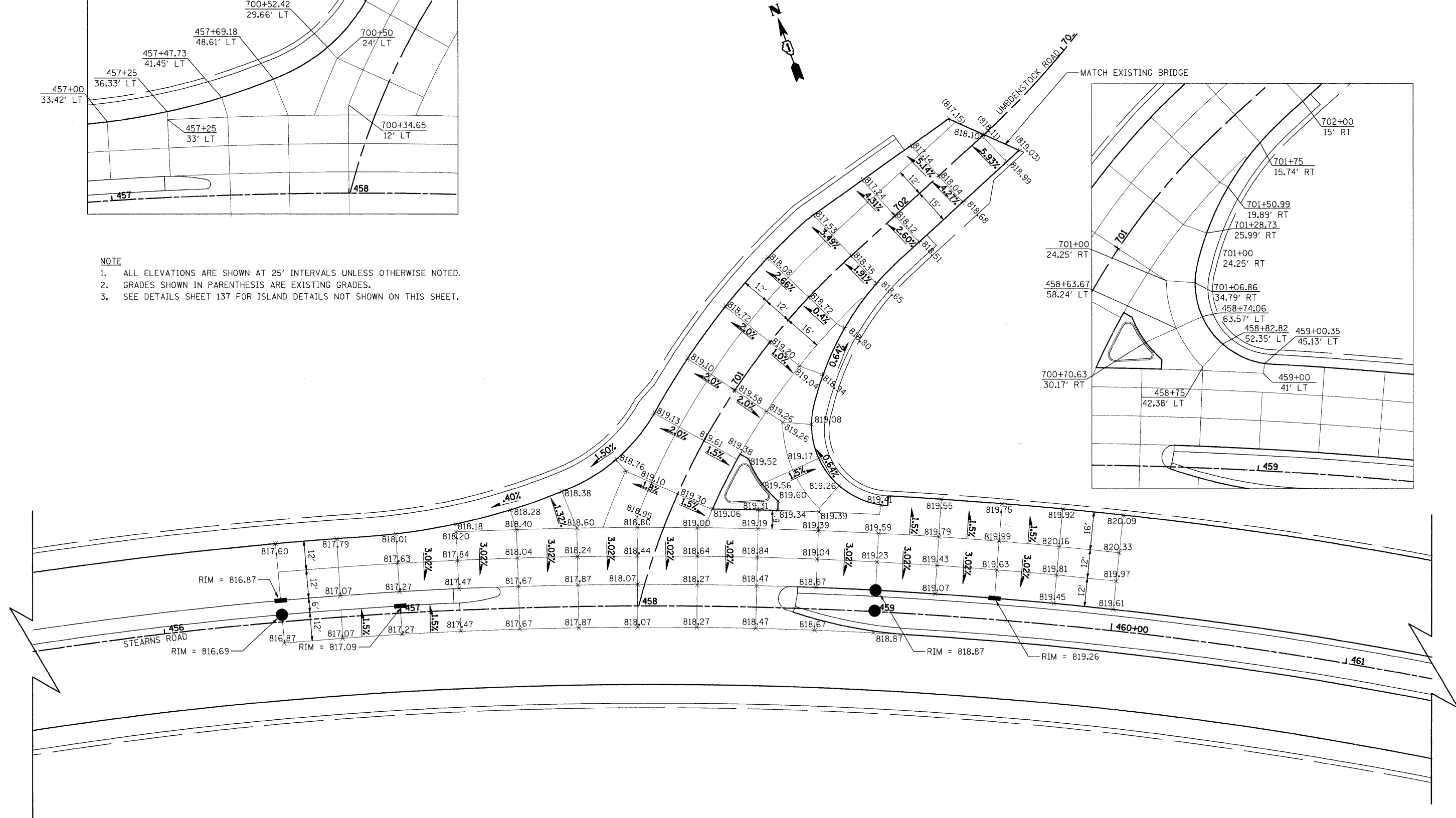

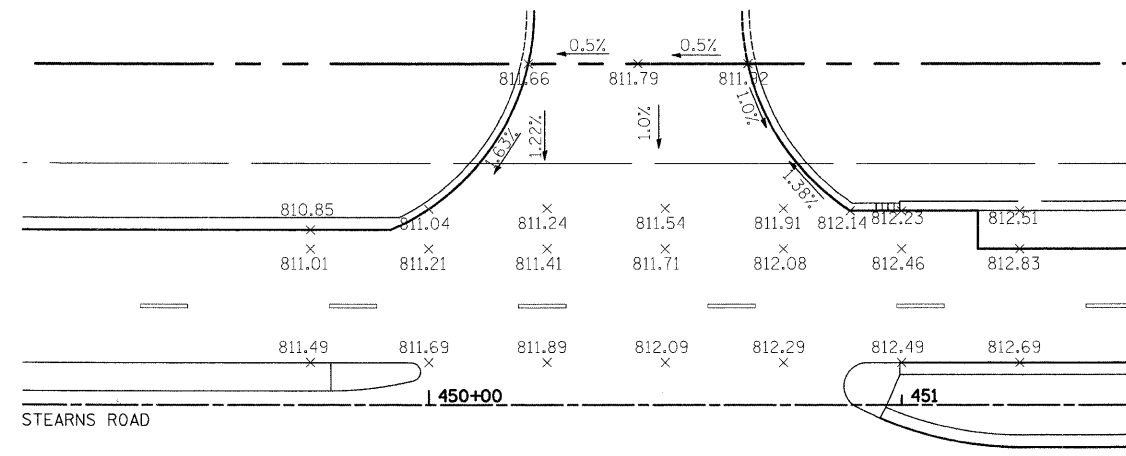

STEARNS ROAD AT DRIVEWAY

FILE NAME = 	USER NAME = eed	DESIGNED - JSM	REVISED -	KANE COUNTY DIVISION OF TRANSPORTATION	GRADING PLAN - STEARNS ROAD			F.A. RTE.	SECTION	COUNTY	TOTAL SHEETS	SHEET NO.
	PLOT SCALE = 20,000.00' / IN.	DRAWN - JSM	REVISED -					361	06-00214-25-BR	KANE	220	93
	PLOT DATE = 3/27/2009	CHECKED - DNM	REVISED -					CONTRACT NO. 63076				
	DATE - 3/30/09	REVISED -	SCALE: 1" = 20'					SHEET NO. 5 OF 6 SHEETS	STA.	TO STA.	FED. ROAD DIST. NO. 1 [ILLINOIS] FED. AID PROJECT	

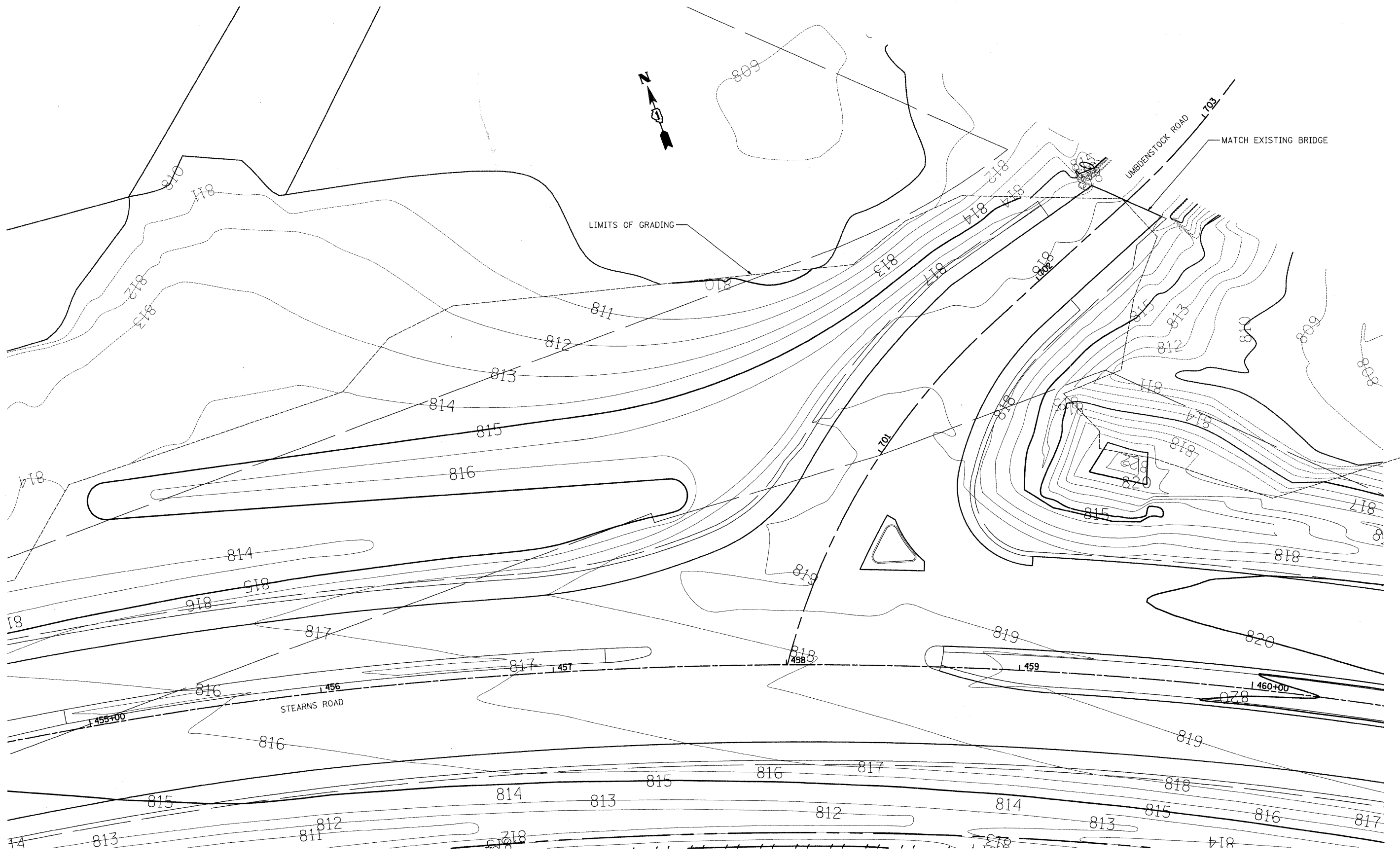

FILE NAME =	USER NAME = eod	DESIGNED - EAD	REVISED -	KANE COUNTY DIVISION OF TRANSPORTATION	CONTOUR PLAN - UMBDENSTOCK ROAD	F.A. RTE.	SECTION	COUNTY	TOTAL SHEETS	SHEET NO.	
		DRAWN - EAD	REVISED -			361	06-00214-25-BR	KANE	220	94	
		CHECKED - DNM	REVISED -			CONTRACT NO. 63076					
		DATE - 3/30/09	REVISED -			FED. ROAD DIST. NO. 1 (ILLINOIS) FED. AID PROJECT					
					SCALE: 1" = 20'	SHEET NO. 6 OF 6 SHEETS		STA. TO STA.			

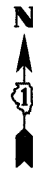

CUSTOM
72"X36"
486+89

6" WHITE SKIP DASH
(2' DASH - 6' SKIP)

WHITE LETTERS &
SYMBOLS (TYP.)

RECESSED PAVEMENT MARKERS

6" WHITE

REMOVE
R3-5L
484+78

R3-8L
30"X30"
484+78

RANDALL ROAD

485+00

NOTE:

ALL PAVEMENT MARKINGS ON HMA PAVEMENT SHALL BE EPOXY PAVEMENT MARKING. ALL PAVEMENT MARKINGS ON CONCRETE PAVEMENT SHALL BE POLYUREA TYPE 1.

ALL EXISTING SIGNS ON RANDALL ROAD & MC DONALD ROAD ARE TO BE REMOVED BY KANE COUNTY. THE CONTRACTOR SHALL CONTACT RAY JOHNSON OF KDOT SIGN SHOP AT 630-669-7912 A MINIMUM OF 72 HOURS PRIOR TO DESIRED TIME OF REMOVAL. THIS SHALL BE DONE AT NO ADDITIONAL COST TO THE CONTRACT.

ALL NEW SIGNS IN COUNTY R.O.W. ARE TO BE FURNISHED AND INSTALLED BY KDOT SIGN SHOP. THE CONTRACTOR SHALL CONTACT RAY JOHNSON AT 630-669-7912 A MINIMUM OF 15 WORKING DAYS PRIOR TO THE DESIRED TIME OF INSTALLATION.

MATCH LINE STA. 477+50
(SEE SHEET NO. 96)

12" WHITE DIAGONALS
(AT 45°)

4" WHITE

6" WHITE SKIP DASH
(2' DASH - 6' SKIP)

MATCH LINE STA. 481+81
(SEE SHEET NO. 96)

6" WHITE

4" WHITE SKIP DASH
(10' DASH - 30' SKIP)

RECESSED PAVEMENT MARKERS

MCDONALD ROAD

430+00

MATCH LINE STA. 433+98
(SEE SHEET NO. 96)

4" WHITE

8" WHITE

12" WHITE DIAGONALS
(AT 45°)

6" WHITE SKIP DASH
(2' DASH - 6' SKIP)

STEARNS ROAD

FILE NAME = 	USER NAME = eed	DESIGNED - JSM DRAWN - EDS	REVISED - REVISED - REVISED - REVISED -	KANE COUNTY DIVISION OF TRANSPORTATION	SIGNING AND PAVEMENT MARKING PLAN			F.A. RTE. 361	SECTION 06-00214-25-BR	COUNTY KANE	TOTAL SHEETS 220	SHEET NO. 95
	PLOT SCALE = 50.0000' / IN. PLOT DATE = 3/27/2009	CHECKED - DNM DATE - 3/30/09	SCALE: 1" = 50' SHEET NO. 1 OF 4 SHEETS STA. TO STA.			CONTRACT NO. 63076			FED. ROAD DIST. NO. 1 [ILLINOIS] FED. AID PROJECT			

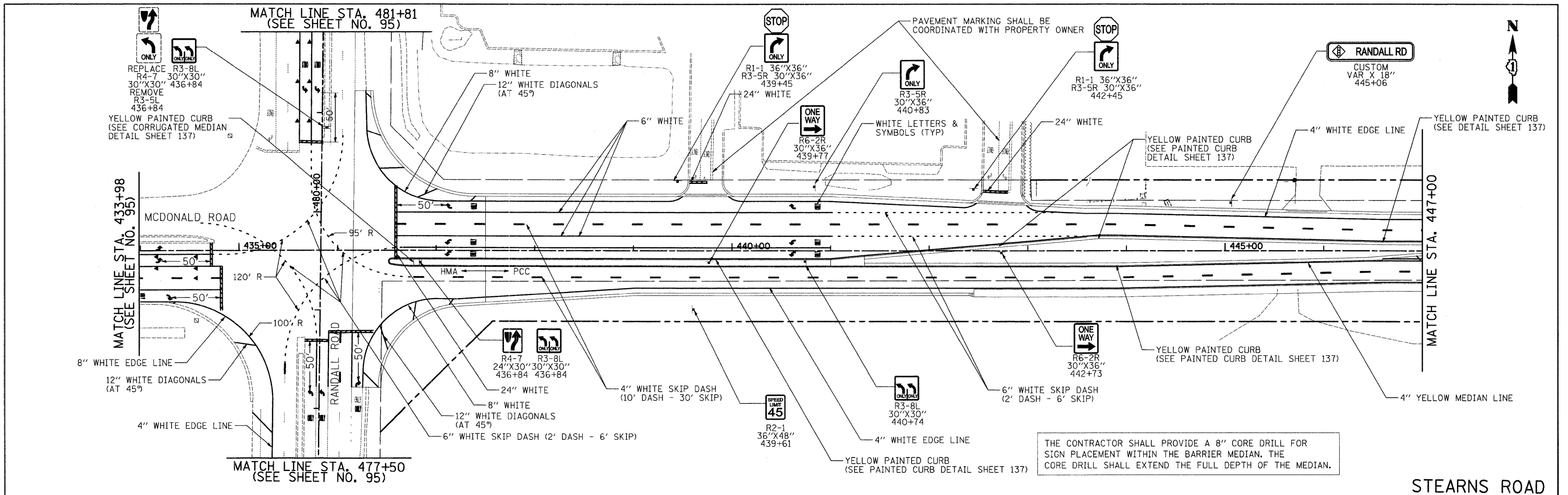

THE CONTRACTOR SHALL PROVIDE A 8" CORE DRILL FOR SIGN PLACEMENT WITHIN THE BARRIER MEDIAN. THE CORE DRILL SHALL EXTEND THE FULL DEPTH OF THE MEDIAN.

NOTE:
 ALL PAVEMENT MARKINGS ON HMA PAVEMENT SHALL BE EPOXY PAVEMENT MARKING. ALL PAVEMENT MARKINGS ON CONCRETE PAVEMENT SHALL BE POLYUREA TYPE 1.

ALL EXISTING SIGNS ON RANDALL ROAD & MC DONALD ROAD ARE TO BE REMOVED BY KANE COUNTY. THE CONTRACTOR SHALL CONTACT RAY JOHNSON OF KDOT SIGN SHOP AT 630-669-7912 A MINIMUM OF 72 HOURS PRIOR TO DESIRED TIME OF REMOVAL. THIS SHALL BE DONE AT NO ADDITIONAL COST TO THE CONTRACT.

ALL NEW SIGNS IN COUNTY R.O.W., EXCEPT THOSE MOUNTED ON TRAFFIC SIGNAL MAST ARMS, ARE TO BE FURNISHED AND INSTALLED BY KDOT SIGN SHOP. THE CONTRACTOR SHALL CONTACT RAY JOHNSON AT 630-669-7912 A MINIMUM OF 15 WORKING DAYS PRIOR TO THE DESIRED TIME OF INSTALLATION.

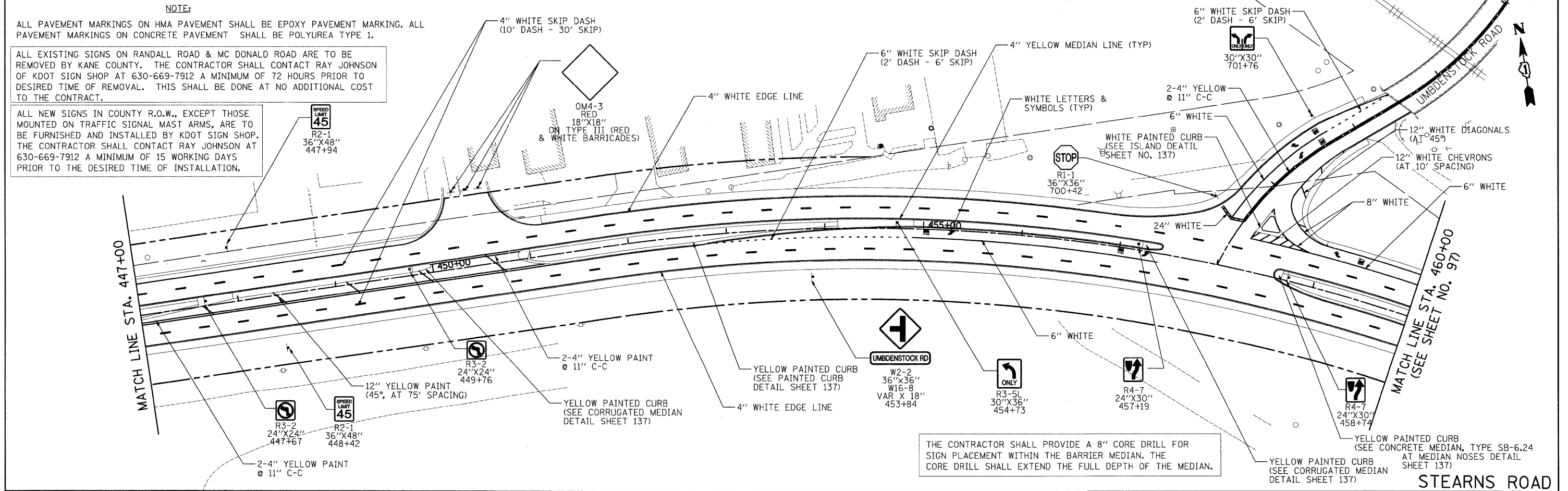

THE CONTRACTOR SHALL PROVIDE A 8" CORE DRILL FOR SIGN PLACEMENT WITHIN THE BARRIER MEDIAN. THE CORE DRILL SHALL EXTEND THE FULL DEPTH OF THE MEDIAN.

FILE NAME = 	USER NAME = ead	DESIGNED - JSM	REVISED -	KANE COUNTY DIVISION OF TRANSPORTATION	SIGNING AND PAVEMENT MARKING PLAN	F.A. RTE. 361	SECTION 06-00214-25-BR	COUNTY KANE	TOTAL SHEETS 220	SHEET NO. 96	
	PLOT SCALE = 50.0000' / IN.	CHECKED - DNM	REVISED -			SCALE: 1" = 50'	SHEET NO. 2 OF 4 SHEETS	STA. 436+00 TO STA. 460+00	FED. ROAD DIST. NO. 1	ILLINOIS FED. AID PROJECT	CONTRACT NO. 63076
	PLOT DATE = 3/27/2009	DATE - 3/30/09	REVISED -								

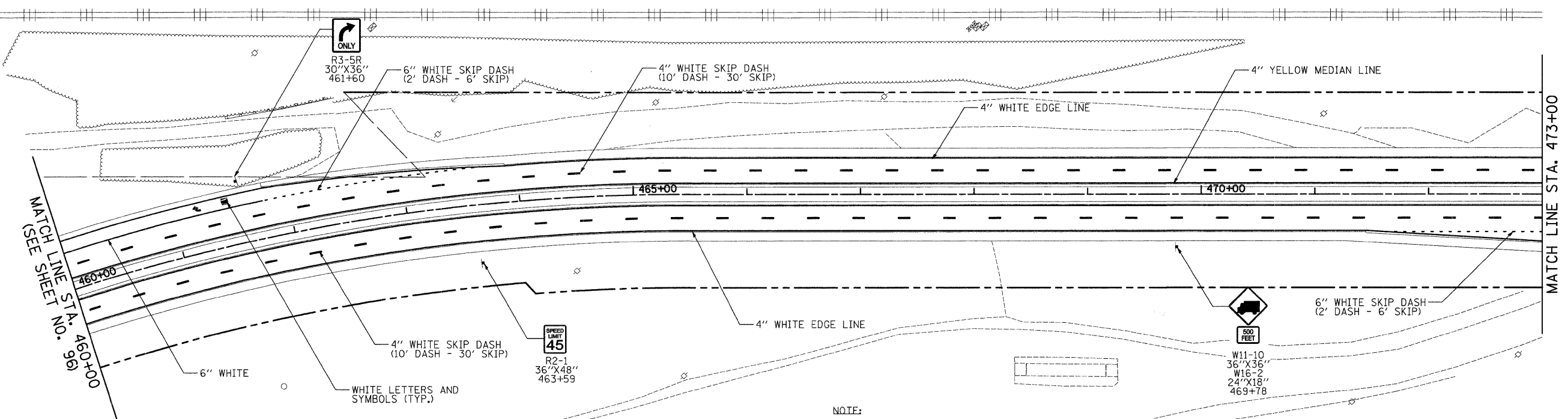
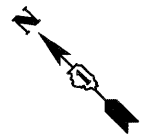

MATCH LINE STA. 460+00
(SEE SHEET NO. 96)

MATCH LINE STA. 475+00

ALL PAVEMENT MARKINGS ON HMA PAVEMENT SHALL BE EPOXY PAVEMENT MARKING. ALL PAVEMENT MARKINGS ON CONCRETE PAVEMENT SHALL BE POLYUREA TYPE 1.

THE CONTRACTOR SHALL PROVIDE A 8" CORE DRILL FOR SIGN PLACEMENT WITHIN THE BARRIER MEDIAN. THE CORE DRILL SHALL EXTEND THE FULL DEPTH OF THE MEDIAN.

ALL NEW SIGNS IN COUNTY R.O.W., EXCEPT THOSE MOUNTED ON TRAFFIC SIGNAL MAST ARMS, ARE TO BE FURNISHED AND INSTALLED BY KDOT SIGN SHOP. THE CONTRACTOR SHALL CONTACT RAY JOHNSON AT 630-669-7912 A MINIMUM OF 15 WORKING DAYS PRIOR TO THE DESIRED TIME OF INSTALLATION.

NOTE:

STEARNS ROAD

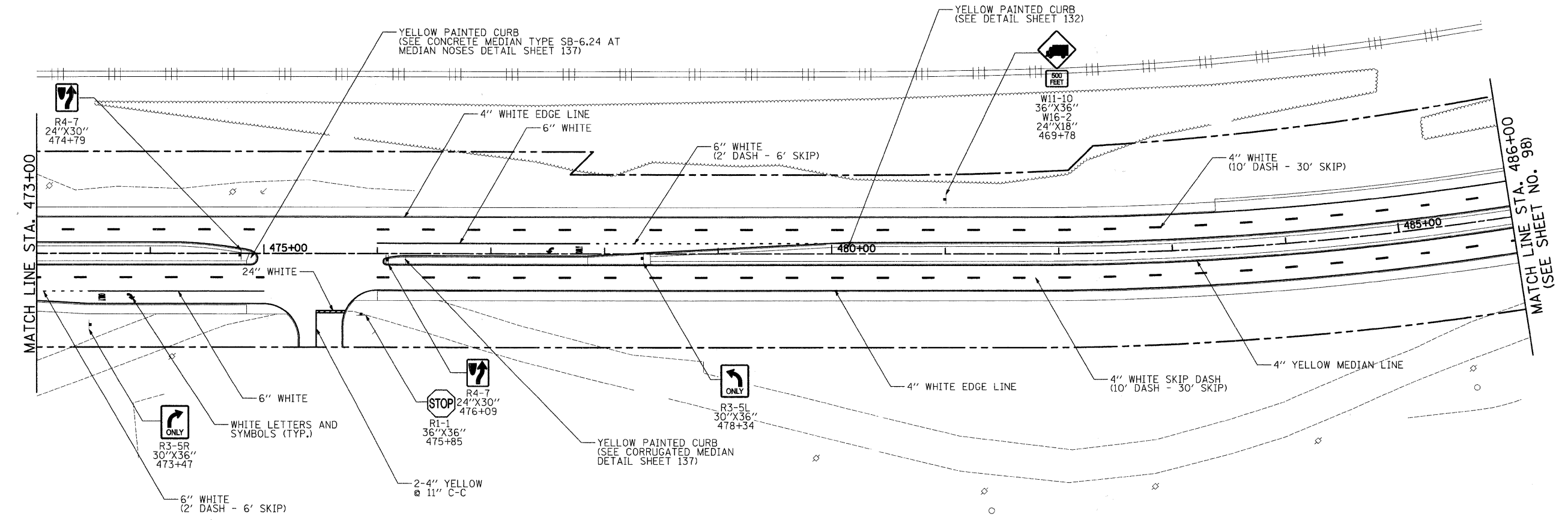

MATCH LINE STA. 473+00

MATCH LINE STA. 486+00
(SEE SHEET NO. 98)

STEARNS ROAD

FILE NAME =	USER NAME = ead	DESIGNED - JSM	REVISED -	KANE COUNTY DIVISION OF TRANSPORTATION	SIGNING AND PAVEMENT MARKING PLAN	F.A. RTE. 361	SECTION 06-00214-25-BR	COUNTY KANE	TOTAL SHEETS 220	SHEET NO. 97
		DRAWN - EDS	REVISED -			CONTRACT NO. 63076				
PLOT SCALE = 50.0000' / IN.		CHECKED - DNM	REVISED -	SCALE: 1" = 50'		SHEET NO. 3 OF 4 SHEETS		STA. 460+00 TO STA. 486+00		FED. ROAD DIST. NO. 1 ILLINOIS FED. AID PROJECT
PLOT DATE = 3/27/2009		DATE - 3/30/09	REVISED -							

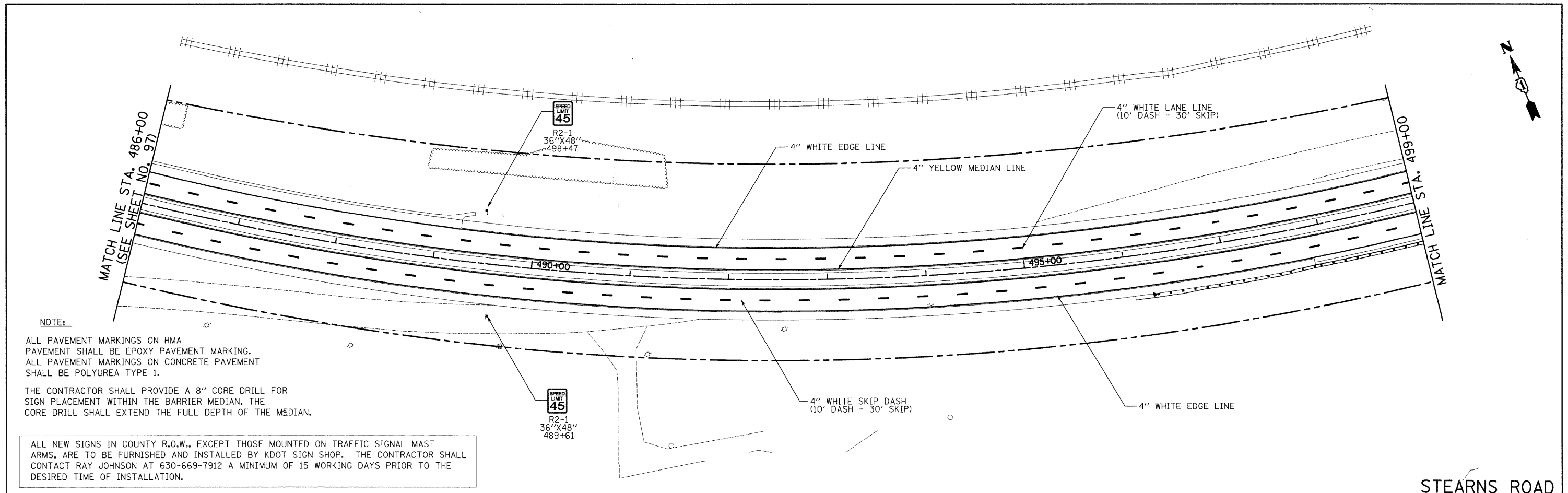

NOTE:
 ALL PAVEMENT MARKINGS ON HMA PAVEMENT SHALL BE EPOXY PAVEMENT MARKING.
 ALL PAVEMENT MARKINGS ON CONCRETE PAVEMENT SHALL BE POLYUREA TYPE 1.
 THE CONTRACTOR SHALL PROVIDE A 8" CORE DRILL FOR SIGN PLACEMENT WITHIN THE BARRIER MEDIAN. THE CORE DRILL SHALL EXTEND THE FULL DEPTH OF THE MEDIAN.

ALL NEW SIGNS IN COUNTY R.O.W., EXCEPT THOSE MOUNTED ON TRAFFIC SIGNAL MAST ARMS, ARE TO BE FURNISHED AND INSTALLED BY KDOT SIGN SHOP. THE CONTRACTOR SHALL CONTACT RAY JOHNSON AT 630-669-7912 A MINIMUM OF 15 WORKING DAYS PRIOR TO THE DESIRED TIME OF INSTALLATION.

STEARNS ROAD

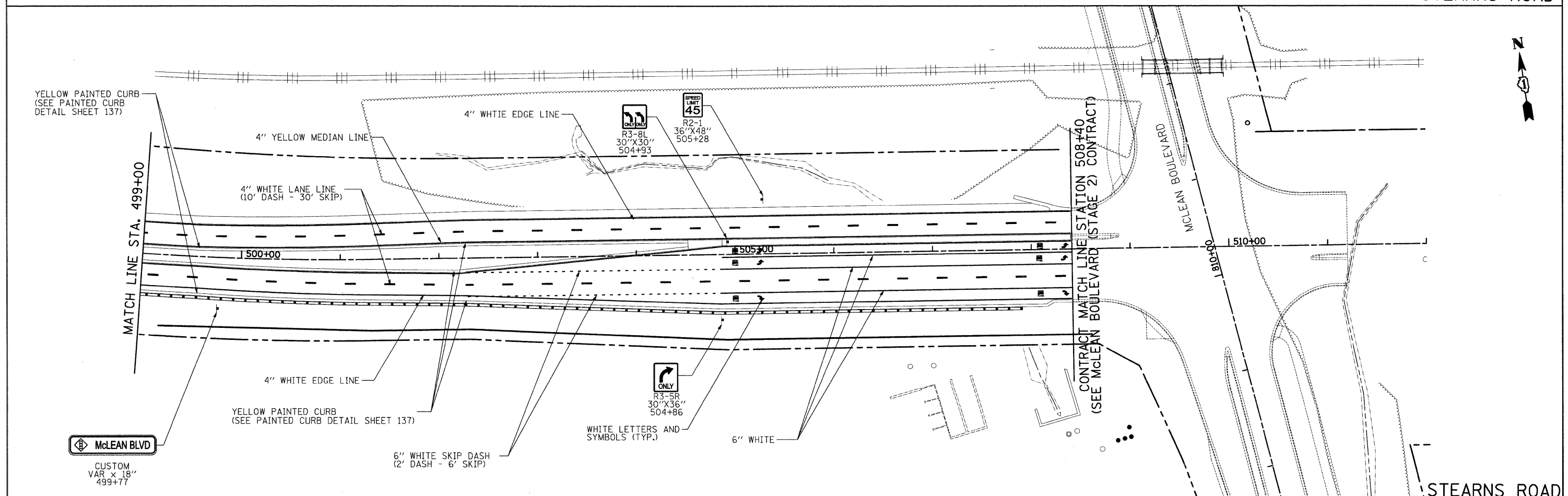

YELLOW PAINTED CURB (SEE PAINTED CURB DETAIL SHEET 137)

YELLOW PAINTED CURB (SEE PAINTED CURB DETAIL SHEET 137)

McLEAN BLVD
 CUSTOM VAR x 18"
 499+77

WHITE LETTERS AND SYMBOLS (TYP.)

STEARNS ROAD

	FILE NAME =	DESIGNED - JSM	REVISED -	KANE COUNTY DIVISION OF TRANSPORTATION	SIGNING AND PAVEMENT MARKING PLAN	F.A. RTE. 361	SECTION 06-00214-25-BR	COUNTY KANE	TOTAL SHEETS 220	SHEET NO. 98			
	USER NAME = ead	DRAWN - EDS	REVISED -			SCALE: 1" = 50'	SHEET NO. 4 OF 4 SHEETS	STA. 486+00 TO STA. 508+40	CONTRACT NO. 63076				
	PLOT SCALE = 50,0000' / IN.	CHECKED - DNM	REVISED -			ILLINOIS/FED. AID PROJECT							
	PLOT DATE = 3/27/2009	DATE - 3/30/09	REVISED -										

TEMPORARY TRAFFIC SIGNAL LEGEND

- TEMPORARY TRAFFIC SIGNAL HEAD
SPAN WIRE MOUNTED ORIGINAL LOCATION
- TEMPORARY TRAFFIC SIGNAL HEAD
SPAN WIRE MOUNTED SECONDARY LOCATION
- TEMPORARY WOOD POLE (CLASS 5 OR
BETTER) 45 FOOT (13.7m) MINIMUM
- TEMPORARY CONTROLLER CABINET
- TEMPORARY SPAN WIRE, TETHER WIRE, AND
CABLE
- TEMPORARY SERVICE INSTALLATION
- TEMPORARY PEDESTRIAN SIGNAL HEAD,
BRACKET MOUNTED
- TEMPORARY PEDESTRIAN PUSHBUTTON DETECTOR
- VIDEO VEHICLE DETECTOR
- PTZ CAMERA
- EMERGENCY VEHICLE LIGHT DETECTOR
- CONFIRMATION BEACON
- VEHICLE DETECTOR, INDUCTION LOOP
- COMMON TRENCH
- UNIT DUCT
- G.S. CONDUIT IN TRENCH OR PUSHED
- HANDHOLE
- HEAVY-DUTY HANDHOLE
- TEMPORARY DETECTION ZONE
- ETHERNET RADIO ANTENNA

EXISTING EQUIPMENT TO BE REMOVED LEGEND

- EXISTING TEMPORARY POLE TO BE REMOVED
- EXISTING CONTROLLER TO BE RELOCATED
- EXISTING HANDHOLE TO BE REMOVED
- EMERGENCY VEHICLE LIGHT DETECTOR TO
BE RELOCATED
- CONFIRMATION BEACON TO BE RELOCATED
- TRAFFIC SIGNAL HEAD TO BE RELOCATED
- LUMINAIRE TO BE RELOCATED
- VIDEO VEHICLE DETECTOR TO BE RELOCATED
- PTZ CAMERA TO BE RELOCATED



THE FOLLOWING ITEMS SHALL BE REMOVED BY THE CONTRACTOR AND SHALL BE DISPOSED OF BY THEM OUTSIDE THE RIGHT-OF-WAY AT THEIR EXPENSE. THE SALVAGE VALUE OF THE REMOVED EQUIPMENT SHALL BE REFLECTED IN THE CONTRACT BID PRICE.

4	EACH	TEMPORARY WOOD POLES
4	EACH	LUMINAIRES
14	EACH	SIGNAL HEAD, 1-FACE, 3-SECTION
6	EACH	SIGNAL HEAD, 1-FACE, 5-SECTION
1	EACH	SERVICE INSTALLATION
730	FOOT	SPAN AND TETHER WIRE
1	EACH	CONTROLLER CABINET

NOTES FOR TEMPORARY TRAFFIC SIGNALS

1. ALL CONTROL EQUIPMENT INCLUDING EMERGENCY PRE-EMPTION AND COMMUNICATION DEVICES FOR THE TEMPORARY TRAFFIC SIGNAL(S) SHALL BE FURNISHED BY THE CONTRACTOR.
2. ONLY CONTROLLERS SUPPLIED BY ONE OF THE DISTRICT APPROVED CLOSED LOOP EQUIPMENT MANUFACTURERS WILL BE APPROVED FOR USE AT TEMPORARY SIGNAL LOCATIONS. ALL CONTROLLERS USED FOR TEMPORARY TRAFFIC SIGNALS SHALL BE FULLY ACTUATED NEMA MICROPROCESSOR BASED WITH RS232 DATA ENTRY PORTS COMPATIBLE WITH EXISTING MONITORING SOFTWARE APPROVED BY IDOT DISTRICT 1. INSTALLED IN A NEMA TS1 OR TS2 CABINET. ONLY ONE BRAND OF CONTROLLER WILL BE ACCEPTED FOR ANY ONE CONTRACT.
3. ALL TRAFFIC SIGNAL SECTIONS AND PEDESTRIAN SIGNAL SECTIONS SHALL BE 12". HEADS SHALL BE PLACED AS INDICATED ON THE TEMPORARY TRAFFIC SIGNAL PLAN OR AS DIRECTED BY THE ENGINEER. THE CONTRACTOR SHALL FURNISH ENOUGH CABLE SLACK TO RELOCATE HEADS TO ANY POSITION ON THE SPAN WIRE OR AT LOCATIONS ILLUSTRATED ON THE PLANS FOR CONSTRUCTION STAGING. IT SHALL BE THE CONTRACTOR'S RESPONSIBILITY TO RELOCATE EXISTING SIGNAL HEADS THROUGHOUT CONSTRUCTION, AND TO VERIFY THE EXISTING CABLE SLACK IS SUFFICIENT TO RELOCATE SIGNAL HEADS AS SHOWN. THE TEMPORARY TRAFFIC SIGNAL SHALL REMAIN IN OPERATION DURING ALL SIGNAL HEAD RELOCATIONS. EACH TEMPORARY TRAFFIC SIGNAL HEAD SHALL HAVE ITS OWN CABLE FROM THE CONTROLLER CABINET TO THE SIGNAL HEAD.
4. ALL EXISTING STREET NAME AND INTERSECTION REGULATORY SIGNS SHALL BE REMOVED FROM EXISTING POLES, RELOCATED AND SECURELY FASTENED TO THE SIGNAL SPAN WIRE OR WOOD POLE AS DIRECTED BY THE ENGINEER.
5. ANY TEMPORARY SIGNAL WITHIN AN EXISTING CLOSED LOOP TRAFFIC SIGNAL SYSTEM SHALL BE INTERCONNECTED TO THAT SYSTEM USING SIMILAR BRAND CONTROL EQUIPMENT.
6. THE TEMPORARY TRAFFIC SIGNAL SHALL HAVE THE SIGNAL HEAD DISPLAYS, SIGNAL HEAD PLACEMENTS AND CONTROLLER PHASING MATCH THE EXISTING TRAFFIC SIGNAL, AT THE TIME OF THE TURN ON, IF NO TRAFFIC STAGING IS IN PLACE OR WILL NOT BE STAGED ON THE DAY OF THE TURN ON.
7. ALL DETECTION ZONES ARE APPROXIMATE. THE EXACT LOCATION SHALL BE DETERMINED AND LAID OUT IN THE FIELD BY THE MANUFACTURER'S TECHNICIAN AS APPROVED BY THE ENGINEER.
8. THE EXISTING EQUIPMENT ON THE NORTH, SOUTH AND EAST APPROACHES SHALL BE RELOCATED TO THE PROPOSED TEMPORARY POLES AND SPAN WIRE.
9. THE CONTRACTOR SHALL BE RESPONSIBLE FOR THE PERFORMANCE OF THE RADIO INTERCONNECT THROUGH ALL CONSTRUCTION STAGES. IF WIRELESS INTERCONNECT FAILS DURING TESTING OR OPERATIONS, OR IS NOT ADEQUATELY MAINTAINING THE SYSTEM ETHERNET CONNECTION, THE CONTRACTOR SHALL BE RESPONSIBLE FOR INSTALLING WOOD POLES, FIBER OPTIC CABLE AND OTHER INFRASTRUCTURE FOR TEMPORARY FIBER OPTIC INTERCONNECT AT NO COST TO THE CONTRACT.

LEFT ON GREEN ARROW ONLY

R10-5
24"x30"

THE FOLLOWING EXISTING TRAFFIC SIGNAL EQUIPMENT SHALL BE REMOVED BY THE CONTRACTOR AND SHALL REMAIN THE PROPERTY OF THE KANE COUNTY DIVISION OF TRANSPORTATION. THE CONTRACTOR SHALL SAFELY STORE AND ARRANGE FOR PICK UP OF ALL EQUIPMENT TO BE RETURNED TO THE COUNTY AS PER THE TRAFFIC SIGNAL SPECIFICATIONS.

1	EACH	CONTROLLER AND COMMUNICATION EQUIPMENT
4	EACH	VIDEO VEHICLE DETECTOR
1	EACH	PAN/TILT/ZOOM CAMERA AND CONTROL SYSTEM
1	EACH	UNINTERRUPTIBLE POWER SUPPLY AND CABINET
1	EACH	FAILURE MANAGEMENT UNIT
2	EACH	LIGHT DETECTOR
1	EACH	LIGHT DETECTOR AMPLIFIER

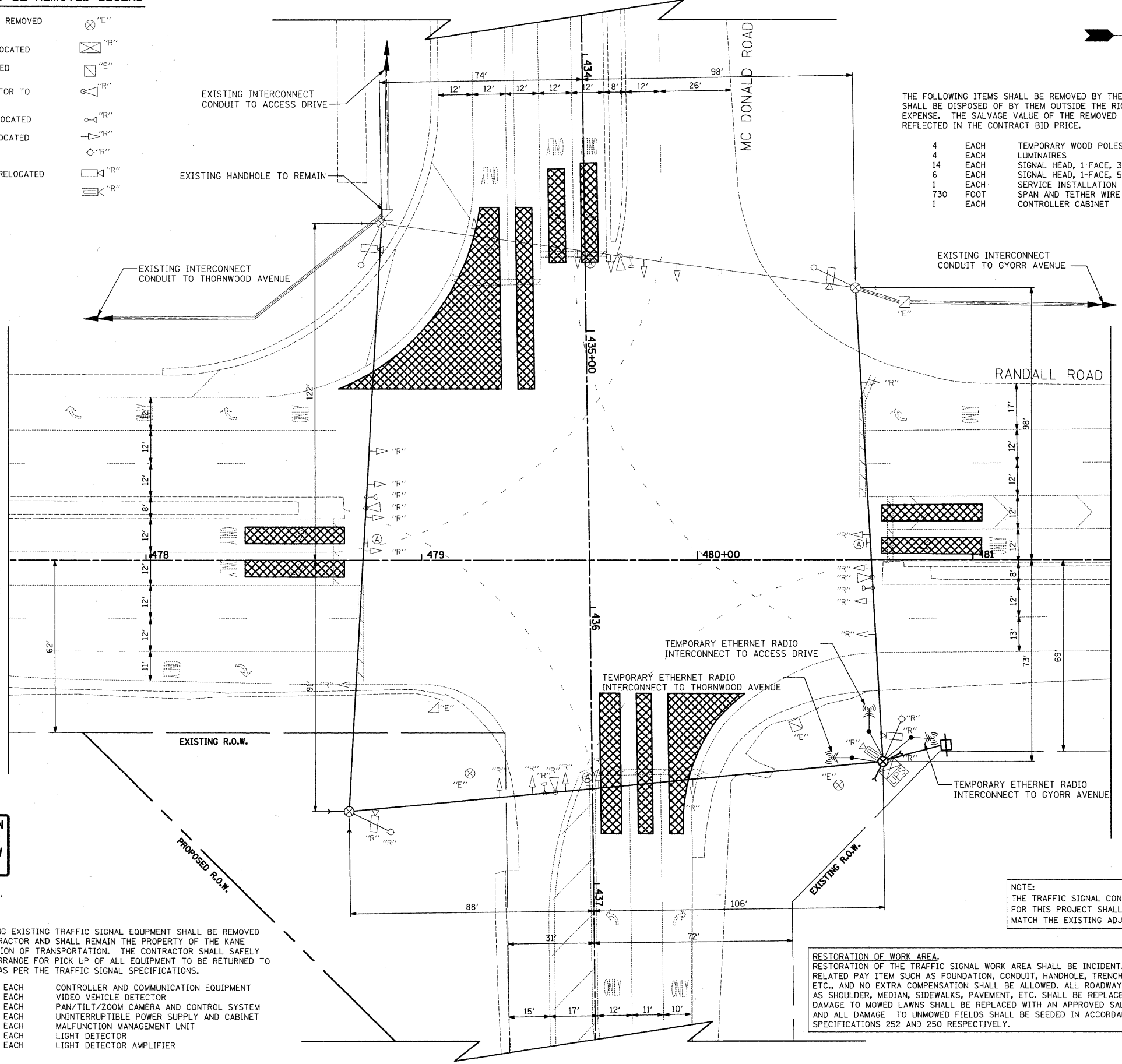

RESTORATION OF WORK AREA.
RESTORATION OF THE TRAFFIC SIGNAL WORK AREA SHALL BE INCIDENTAL TO THE RELATED PAY ITEM SUCH AS FOUNDATION, CONDUIT, HANDHOLE, TRENCH AND BACKFILL, ETC., AND NO EXTRA COMPENSATION SHALL BE ALLOWED. ALL ROADWAY SURFACES SUCH AS SHOULDER, MEDIAN, SIDEWALKS, PAVEMENT, ETC. SHALL BE REPLACED IN KIND. ALL DAMAGE TO MOWED LAWNS SHALL BE REPLACED WITH AN APPROVED SALT TOLERANT SOD, AND ALL DAMAGE TO UNMOWED FIELDS SHALL BE SEEDING IN ACCORDANCE WITH STANDARD SPECIFICATIONS 252 AND 250 RESPECTIVELY.

NOTE:
THE TRAFFIC SIGNAL CONTROLLER EQUIPMENT FOR THIS PROJECT SHALL BE "EAGLE" TO MATCH THE EXISTING ADJACENT SYSTEM.

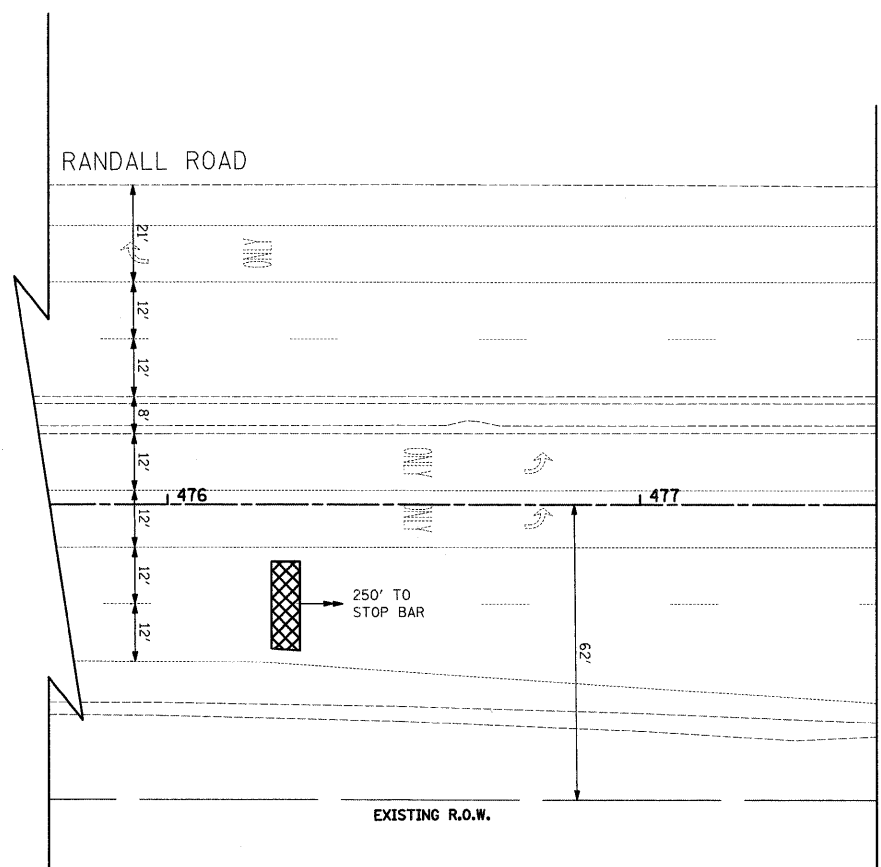

MATCH LINE B
(SEE SHEET 1 OF 2)

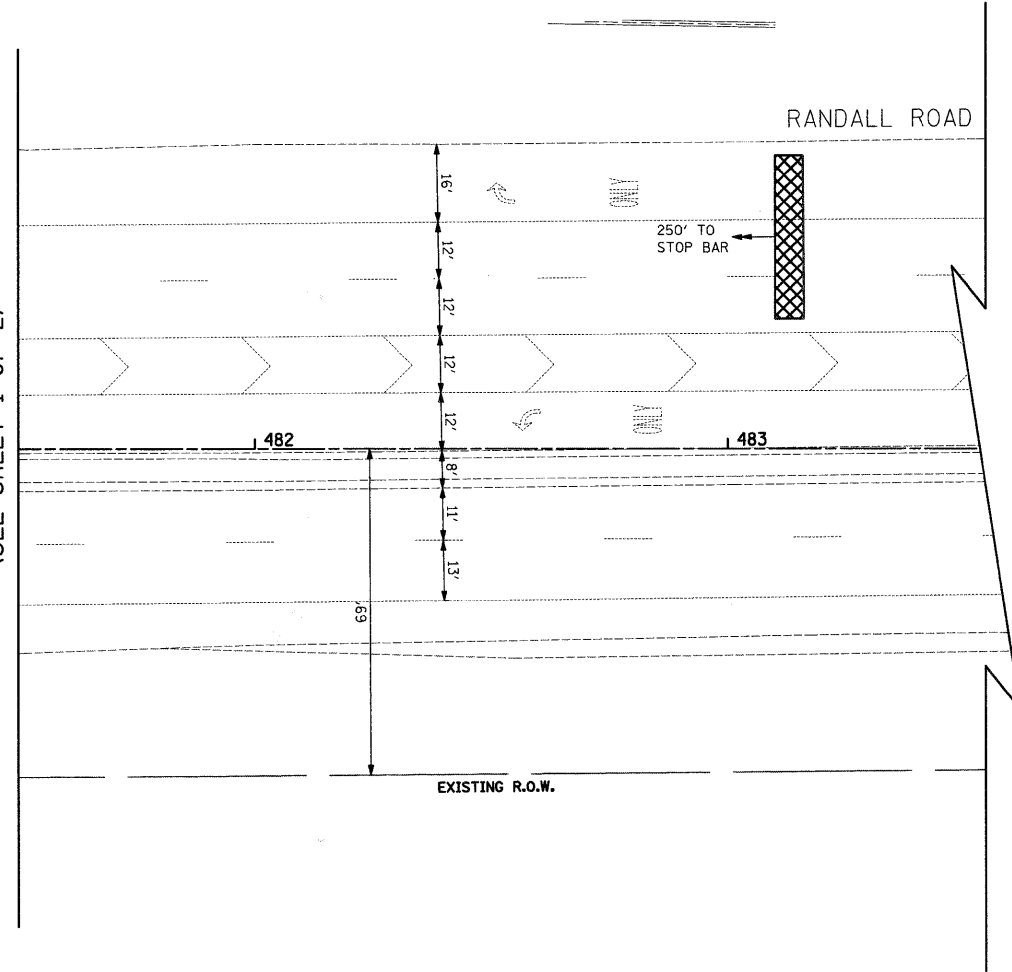

MATCH LINE A
(SEE SHEET 1 OF 2)

TEMPORARY TRAFFIC SIGNAL LEGEND

- TEMPORARY TRAFFIC SIGNAL HEAD
SPAN WIRE MOUNTED ORIGINAL LOCATION
- TEMPORARY TRAFFIC SIGNAL HEAD
SPAN WIRE MOUNTED SECONDARY LOCATION
- TEMPORARY WOOD POLE (CLASS 5 OR
BETTER) 45 FOOT (13.7m) MINIMUM
- TEMPORARY CONTROLLER CABINET
- TEMPORARY SPAN WIRE, TETHER WIRE, AND
CABLE
- TEMPORARY SERVICE INSTALLATION
- TEMPORARY PEDESTRIAN SIGNAL HEAD,
BRACKET MOUNTED
- TEMPORARY PEDESTRIAN PUSHBUTTON DETECTOR
- VIDEO VEHICLE DETECTOR
- PTZ CAMERA
- EMERGENCY VEHICLE LIGHT DETECTOR
- CONFIRMATION BEACON
- VEHICLE DETECTOR, INDUCTION LOOP
- COMMON TRENCH
- UNIT DUCT
- G.S. CONDUIT IN TRENCH OR PUSHED
- HANDHOLE
- HEAVY-DUTY HANDHOLE
- TEMPORARY DETECTION ZONE
- ETHERNET RADIO ANTENNA

EXISTING EQUIPMENT TO BE REMOVED LEGEND

- EXISTING TEMPORARY POLE TO BE REMOVED
- EXISTING CONTROLLER TO BE RELOCATED
- EXISTING HANDHOLE TO BE REMOVED
- EMERGENCY VEHICLE LIGHT DETECTOR TO
BE RELOCATED
- CONFIRMATION BEACON TO BE RELOCATED
- TRAFFIC SIGNAL HEAD TO BE RELOCATED
- LUMINAIRE TO BE RELOCATED
- VIDEO VEHICLE DETECTOR TO BE RELOCATED
- PTZ CAMERA TO BE RELOCATED

NOTE:
THE TRAFFIC SIGNAL CONTROLLER EQUIPMENT
FOR THIS PROJECT SHALL BE "EAGLE" TO
MATCH THE EXISTING ADJACENT SYSTEM.

RESTORATION OF WORK AREA.
RESTORATION OF THE TRAFFIC SIGNAL WORK AREA SHALL BE INCIDENTAL TO THE
RELATED PAY ITEM SUCH AS FOUNDATION, CONDUIT, HANDHOLE, TRENCH AND BACKFILL,
ETC., AND NO EXTRA COMPENSATION SHALL BE ALLOWED. ALL ROADWAY SURFACES SUCH
AS SHOULDER, MEDIAN, SIDEWALKS, PAVEMENT, ETC. SHALL BE REPLACED IN KIND. ALL
DAMAGE TO MOWED LAWNS SHALL BE REPLACED WITH AN APPROVED SALT TOLERANT SOD,
AND ALL DAMAGE TO UNMOWED FIELDS SHALL BE SEEDED IN ACCORDANCE WITH STANDARD
SPECIFICATIONS 252 AND 250 RESPECTIVELY.

FILE NAME =		USER NAME = CIVILTECH ENGINEERING, INC.	DESIGNED - JSH	REVISED -	KANE COUNTY DIVISION OF TRANSPORTATION	TEMPORARY TRAFFIC SIGNAL MODIFICATION AND REMOVAL PLAN (SHEET 2 OF 2) RANDALL ROAD & MC DONALD ROAD			F.A.P. RTE. 361	SECTION 06-00214-25-BR	COUNTY KANE	TOTAL SHEETS 220	SHEET NO. 100
			DRAWN - AKW	REVISED -		SCALE: 1"=20' SHEET NO. 2 OF 23 SHEETS STA. TO STA.			CONTRACT NO. 63076				
			CHECKED - BRD	REVISED -		FED. ROAD DIST. NO. 7 ILLINOIS FED. AID PROJECT							
			DATE - 3/30/09	REVISED -									