

DETAILS AT ENTRANCES AND SIDEROADS

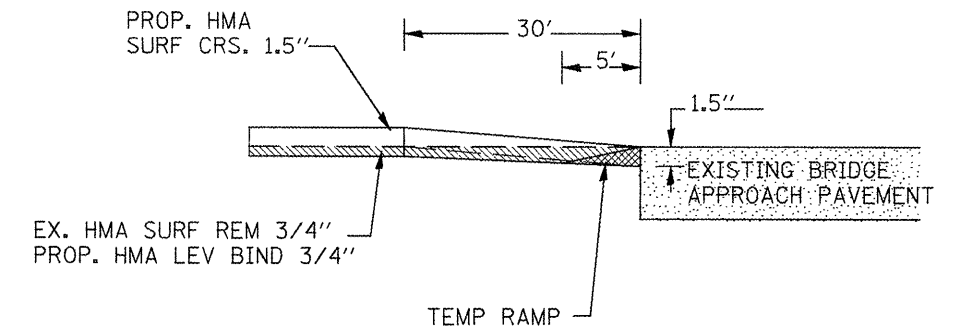

TEMP RAMP AT STRUCTURE

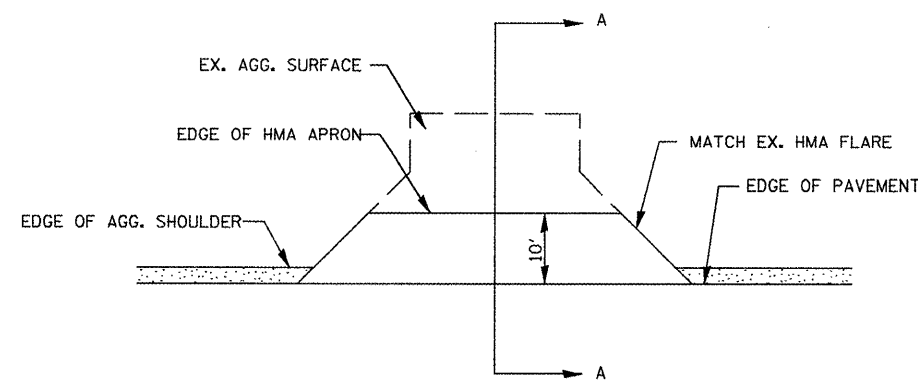

PLAN AT SIDEROADS

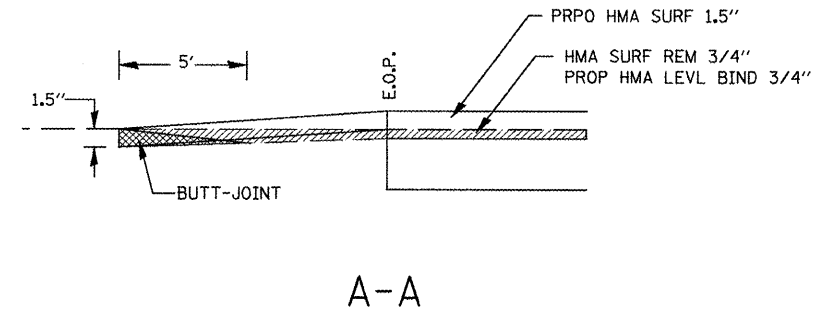

**NOTE:**

THE COST OF REMOVAL AT EXISTING HMA SIDEROADS LOCATIONS SHALL BE PAID FOR AS HMA SURFACE REMOVAL BUTT-JOINT. SEE SCHEDULE OF QUANTITIES FOR BUTT JOINT TREATMENT AT SIDE ROADS.

THE COST OF REMOVAL AT EXISTING HMA PRIVATE OR COMMERCIAL ENTRANCES LOCATIONS SHALL NOT BE PAID FOR AS HMA SURFACE REMOVAL BUTT-JOINT BUT IT SHALL BE INCLUDED IN THE COST OF THE HMA MATERIALS.

CHIP AND SEAL OR AGGREGATE FOR PRIVATE OR COMMERCIAL ENTRANCES SHALL BE FEATHER TAPERED.

FILE NAME = Typical Section.dgn	USER NAME = jlababidism	DESIGNED -	REVISED -	<b>STATE OF ILLINOIS DEPARTMENT OF TRANSPORTATION</b>	<b>IL 26 SIDE ROAD AND ENTRANCE DETAILS</b>	F.A.S. RTE. 2370	SECTION (29,32,33,34)RS-3	COUNTY WOODFORD	TOTAL SHEETS 56	SHEET NO. 50	
	PLOT SCALE = 100.0000' / IN.	DRAWN -	REVISED -			SCALE:	SHEET NO. OF SHEETS	STA. TO STA.	CONTRACT NO. 68401		ILLINOIS FED. AID PROJECT
	PLOT DATE = 1/26/2009	CHECKED -	REVISED -								
		DATE -	REVISED -								