

FAP	FAU	SECTION	COUNTY	TOTAL SHEETS	SHEET NO.
656	6757			33	29
IL. 29 US 150		STA.	TO STA.		
FED. ROAD DIST. NO.		ILLINOIS	FED. AID PROJECT		

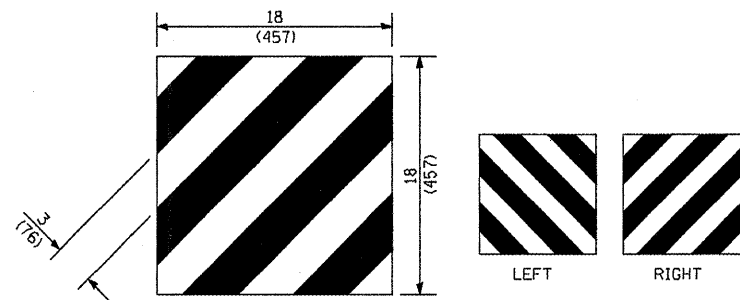

For Traffic Barrier Terminal Type 1 (Special)

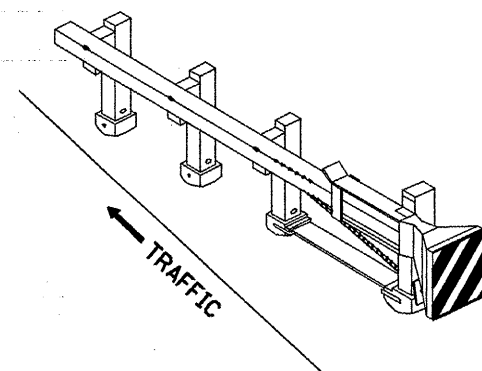

Standard Treatment - Direct Applied Sheeting  
Traffic Barrier Terminal Type 1 (Special)

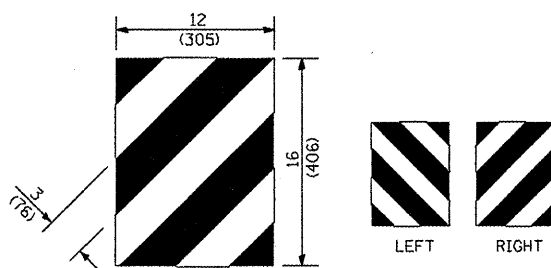

For Traffic Barrier Terminal Type (\*)  
and Post Mount  
\* See Plans for Type

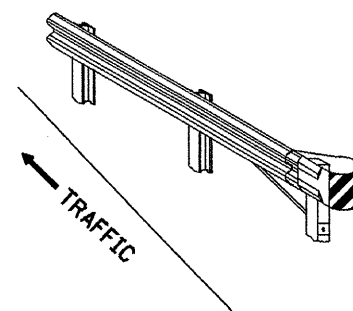

Standard Treatment - Direct Applied Sheeting  
Traffic Barrier Terminal Type (\*)  
\* See Plans for Type

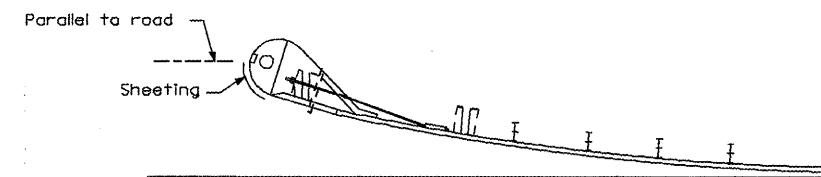

Sheeting Position for  
Traffic Barrier Terminal Type (\*)  
\* See Plans for Type

**TERMINAL MARKER DETAILS**

- Color: Black / Yellow reflectorized
- OM - I100 (L or R) Direct applied reflective sheeting
- OM - I200 (L or R) Post mounted

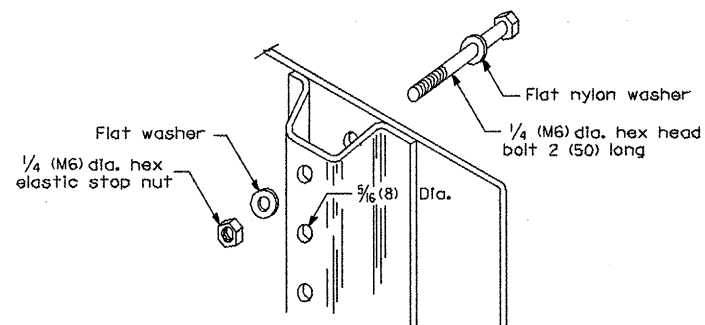

DETAIL OF MOUNTING TERMINAL MARKER TO POST

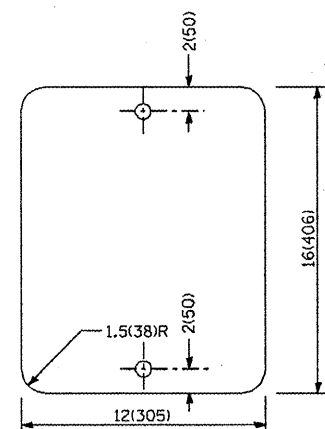

STANDARD TERMINAL MARKER

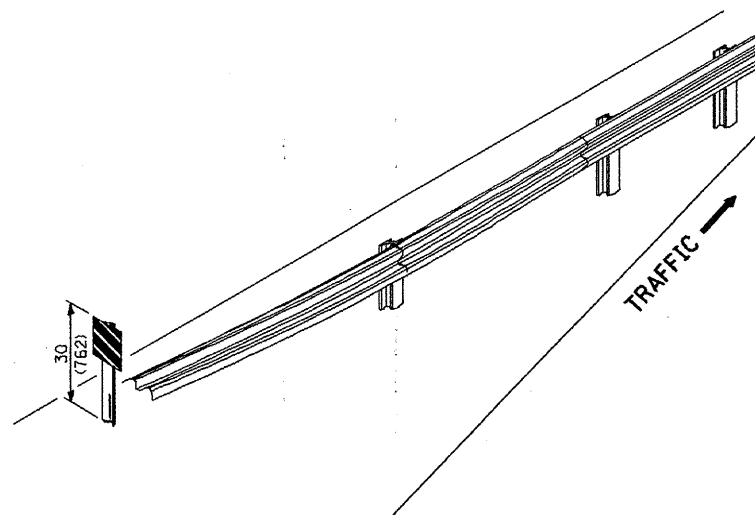

ALTERNATE TREATMENT - POST MOUNTED  
(For turned-down terminal where sheeting cannot be direct applied)

**TERMINAL MARKER TREATMENTS**

**GENERAL NOTES**

All dimensions are in inches (millimeters) unless otherwise noted.

ILLINOIS DEPARTMENT OF TRANSPORTATION  
DISTRICT CADD STANDARD

GUARDRAIL AND  
BARRIER WALL DELINEATION

CADD STD. NO. 635101-D4  
SCALE: NOT DRAWN TO SCALE

SHEET 2 OF 3  
DRAWN BY CADD  
CHECKED BY