

12/15/2008

F.A.P. RTE.	SECTION	COUNTY	TOTAL SHEETS	SHEET NO.
310	60-15VB-1 & 2	MADISON	149	124
STA.		TO STA.		
FED. ROAD DIST. NO.		ILLINOIS	FED. AID PROJECT	
				CONTRACT NO. 7663A

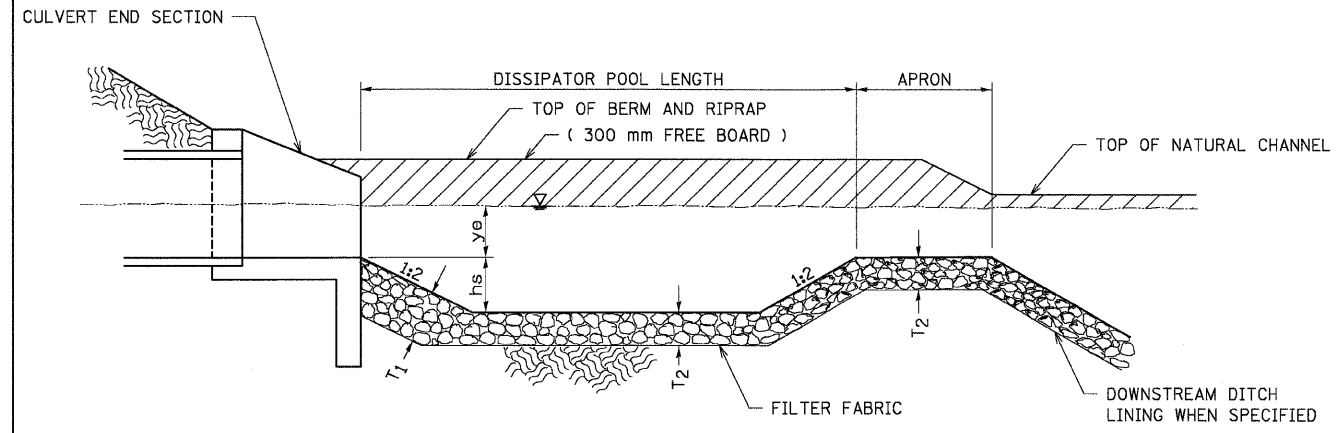

SECTION

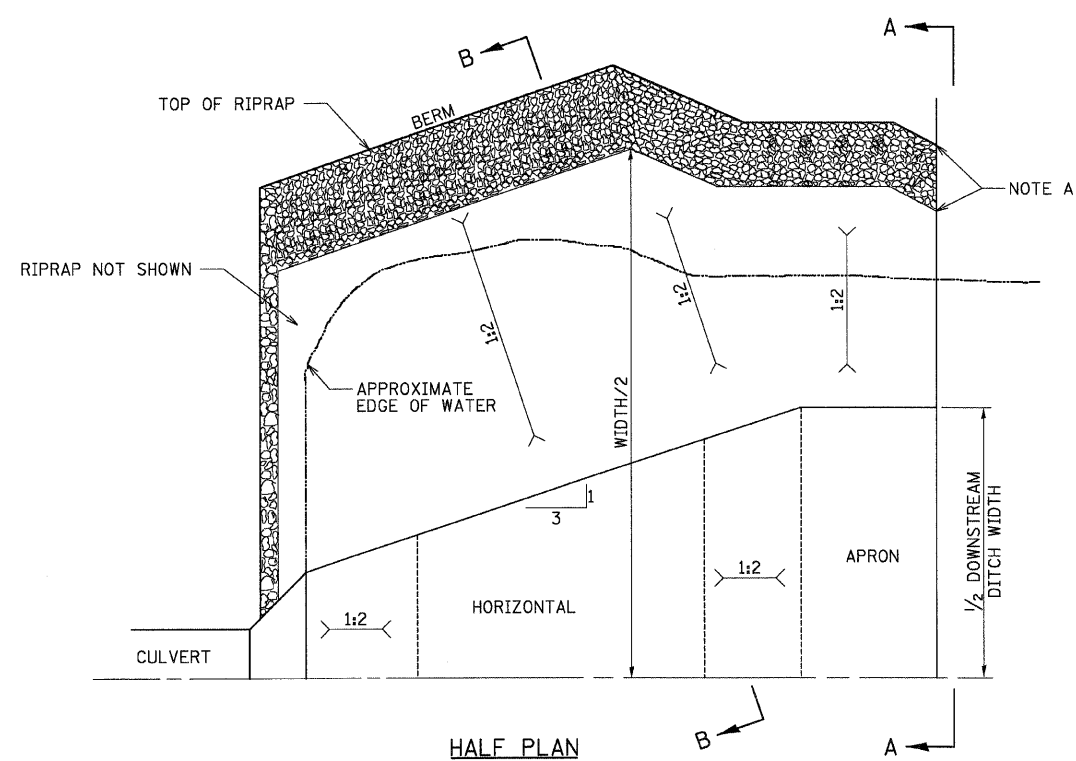

HALF PLAN

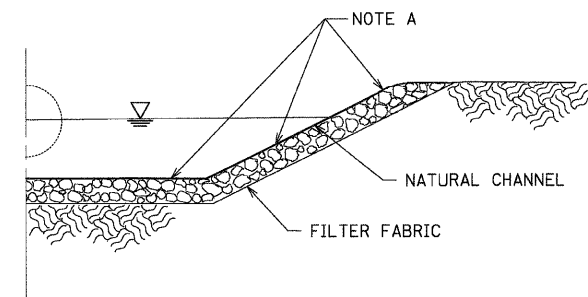

SECTION A-A

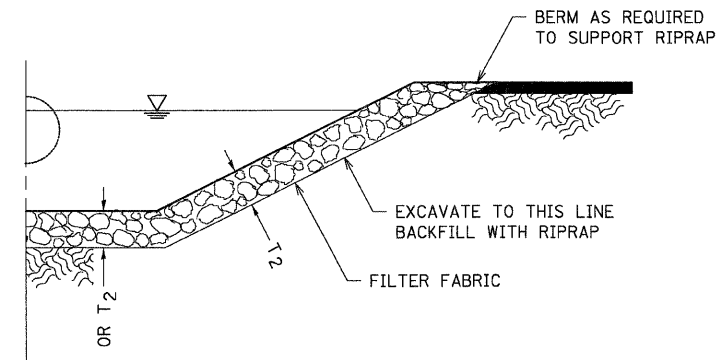

SECTION B-B

**EARTH EXCAVATION FOR ENERGY DISSIPATING BASINS**

THIS WORK INVOLVES THE EXCAVATION OF EARTH AS SHOWN IN THE DETAIL TO THE LENGTH, WIDTH, AND DEPTH DETERMINED BY THE ENGINEER. THE EARTH EXCAVATION WILL BE UTILIZED IN THE ROADWAY EMBANKMENT OR WASTED AS DIRECTED BY THE ENGINEER.

THE EARTHWORK WILL NOT BE PAID FOR SEPARATELY. IT WILL BE CONSIDERED AS INCLUDED IN THE CONTRACT UNIT PRICE PER METRIC TON FOR "RIPRAP FOR STILLING BASIN".

ENERGY DISSIPATING BASINS SHALL BE CONSTRUCTED AT THE SAME TIME AS THE CULVERT OR DITCH.

ENERGY DISSIPATING BASINS ARE TO BE CONSTRUCTED AT LOCATIONS LISTED IN THE TABLE ON THIS SHEET AND AS SHOWN IN THE PLANS.

**RIPRAP FOR ENERGY DISSIPATING BASINS**

RIPRAP FOR ENERGY DISSIPATING BASINS SHALL BE CONSTRUCTED IN ACCORDANCE WITH SECTION 281 OF THE STANDARD SPECIFICATIONS.

THE LENGTH, WIDTH, AND DEPTH FOR RIPRAP PLACEMENT WILL BE DETERMINED BY THE ENGINEER.

THE RIPRAP MATERIAL SHALL MEET A QUALITY DESIGNATION OF A AS DEFINED IN SECTION 1005.01 OF THE STANDARD SPECIFICATIONS.

BEDDING MATERIAL WILL NOT BE REQUIRED.

FILTER FABRIC WILL BE PAID FOR AT THE CONTRACT UNIT PRICE PER SQUARE METER FOR "FILTER FABRIC".

STATION	SIDE	LOCATION	DISSIPATOR POOL LENGTH	APRON LENGTH	WIDTH (W)	hs	TOP OF BERM hs + ye + 300 mm	RIPRAP THICKNESS		RIPRAP CLASS	RIPRAP FOR STILLING BASIN	FILTER FABRIC
								T <sub>1</sub>	T <sub>2</sub>			
			m	m	m	m	m	mm	mm			sm
39+225	LT	FAP 310	5.4	1.9	13.4	0.4	2.0	1.0	0.8	A-5	203.4	101.1

\* NOT APPLICABLE - SEE CROSS SECTION

**NOTE A:**

TRANSITION BASIN TO CONFORM TO THE NATURAL STREAM CHANNEL. TOP OF RIPRAP IN THE FLOOR OF THE BASIN SHOULD BE AT THE SAME ELEVATION OR LOWER THAN THE NATURAL CHANNEL BOTTOM AT SECTION "C SECTION".

REVISIONS	
NAME	DATE

ILLINOIS DEPARTMENT OF TRANSPORTATION  
**ENERGY DISSIPATING BASIN**  
 FAP 310 (IL 255)  
 SECTION 60-15VB-1 & 2  
 MADISON COUNTY  
 DRAWN BY EBB  
 CHECKED BY  
 DATE

p:\00f\iles\000024\dRailroad-Bridge\ROADPLANS\miscellaneous\detail\dgn