

F.A.I. RTE.	SECTION	COUNTY	TOTAL SHEETS	SHEET NO.
70		MADISON	420	218
STA.	TO STA.			
FED. ROAD DIST. NO.	ILLINOIS FED. AID PROJECT			
	• 60-10K-1, 60-10HB CONTRACT NO. 76709			

BILL OF MATERIAL RAMP "D"

Bar	No.	Size	Length	Shape
a ₅₂ (E)	76	#4	6'-8"	
a ₅₃ (E)	76	#4	5'-8"	
a ₅₆ (E)	88	#9	34'-9"	
a ₅₉ (E)	14	#4	4'-8"	
a ₆₀ (E)	14	#4	4'-2"	
a ₆₁ (E)	6	#4	4'-8"	
a ₆₂ (E)	37	#9	19'-3"	
a ₆₃ (E)	12	#9	32'-3"	
a ₆₄ (E)	5	#9	25'-11"	
a ₆₅ (E)	74	#5	23'-3"	
a ₆₆ (E)	31	#5	31'-3"	
b ₅₅ (E)	60	#5	5'-3"	
b ₅₆ (E)	60	#5	6'-8"	
b ₅₉ (E)	10	#5	6'-4"	
b ₆₀ (E)	4	#4	5'-10"	
b ₆₁ (E)	90	#5	31'-3"	
b ₆₂ (E)	24	#4	31'-0"	
d(E)	68	#5	3'-2"	
d ₂ (E)	68	#4	3'-2"	
d ₅₂ (E)	66	#5	3'-0"	
d ₅₃ (E)	66	#4	3'-0"	
e ₅₃ (E)	12	#4	19'-7"	
e ₅₄ (E)	4	#8	32'-8"	
e ₅₅ (E)	4	#5	31'-6"	
e ₆₀ (E)	6	#4	21'-1"	
h ₅₀ (E)	6	#5	4'-4"	
h ₅₁ (E)	24	#5	4'-4"	
h ₅₄ (E)	12	#5	8'-11"	
h ₅₅ (E)	18	#5	2'-1"	
h ₅₆ (E)	24	#5	4'-6"	
h ₅₇ (E)	72	#5	25'-8"	
* Reinforcement Bars, Epoxy Coated	Pound		26,130	
* Concrete	Cu. Yd.		135.4	
* Preformed Joint Seal	Foot		83	
* Concrete Pad	Sq. Yd.		55	
* Polyethylene Bond Breaker	Sq. Yd.		55	
Bridge Approach Pavement (Special)	Sq. Yd.		270	

* Items included in the cost for Bridge Approach Pavement, (Special)

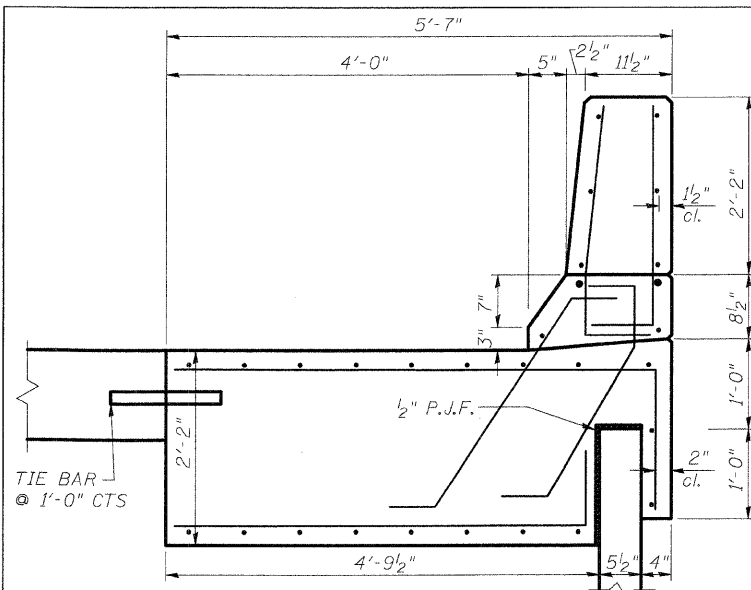

SECTION K-K
(S.N. 060-W003)

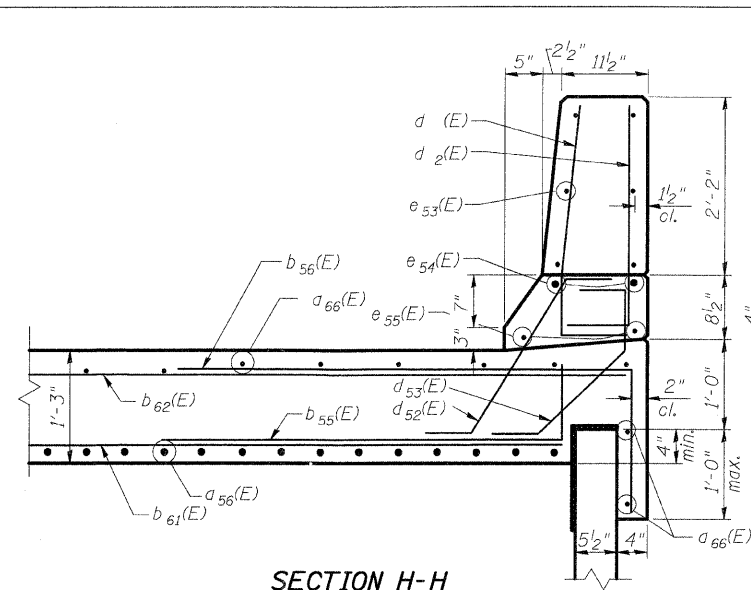

SECTION H-H

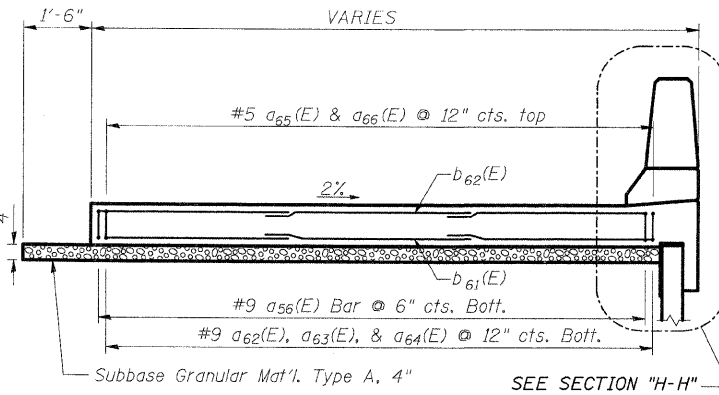

SECTION B-B

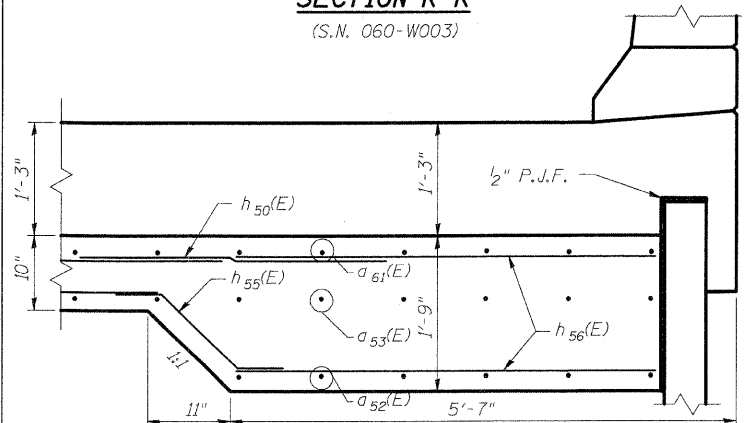

SECTION L-L

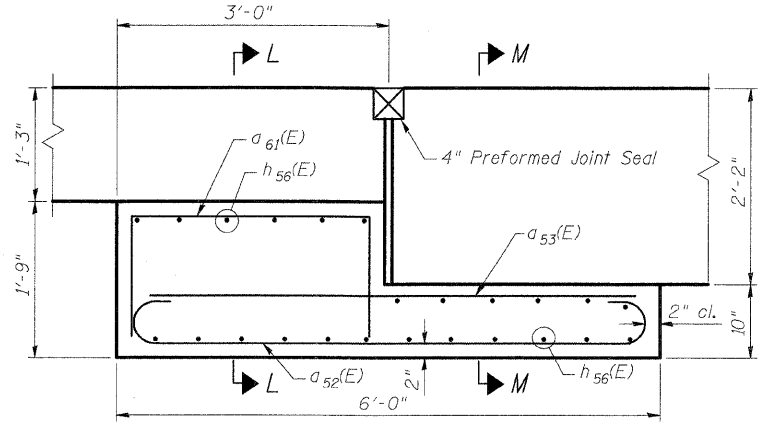

SECTION E-E

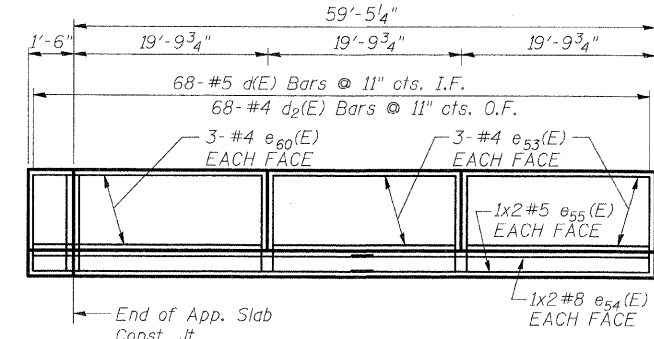

INSIDE PARAPET ELEVATION AT RAMP "B" APPROACH SLAB (SPECIAL)

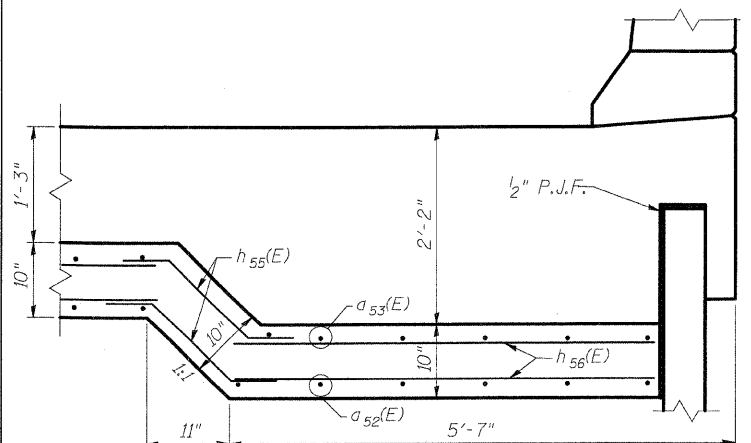

SECTION M-M

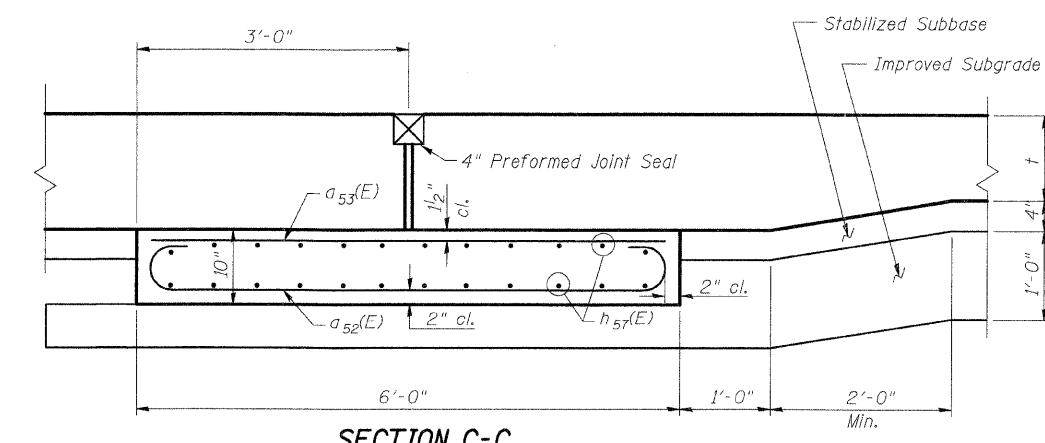

SECTION C-C

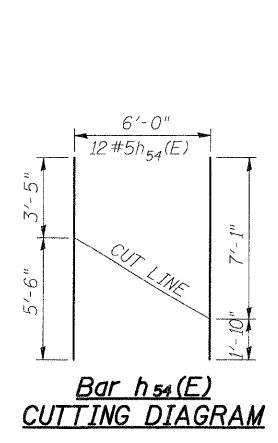

Bar h₅₄(E) CUTTING DIAGRAM

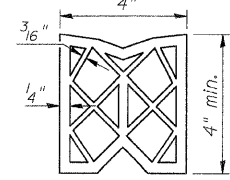

PREFORMED JOINT SEAL

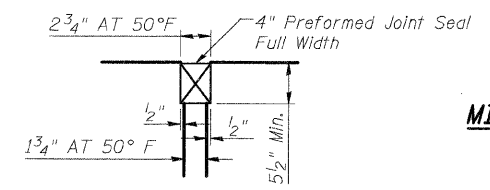

DETAIL 1

MINIMUM BAR LAP

- #4 bars = 1'-8"
- #5 bars = 2'-2"
- #9 bars = 5'-9"

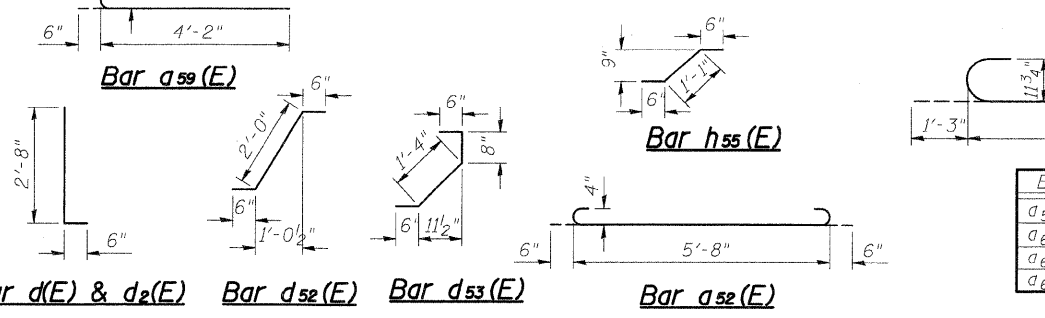
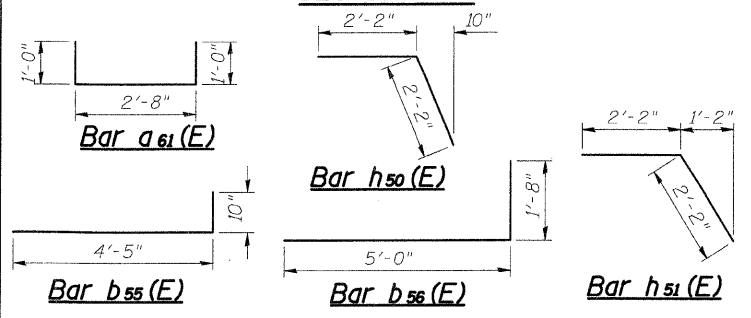

Bar	A
a ₅₆ (E)	33'-6"
a ₆₂ (E)	18'-0"
a ₆₃ (E)	31'-0"
a ₆₄ (E)	24'-8"

STV Incorporated
Engineers/Architects/Planners/Construction Managers
200 W. Monroe Street, Suite 1650
Chicago, IL 60606-5015
312.553.9655, FAX 312.553.0661

SHT. 2 of 2

REVISIONS	
NAME	DATE

ILLINOIS DEPARTMENT OF TRANSPORTATION
IL ROUTE 162 OVER I-55/70 IN TROY
F.A.I ROUTE 70 SECTION 60-10K-1, 60-10HB
MADISON COUNTY STATION 499+48.35
STRUCTURE NO. 060-0338

RAMP D APPROACH SLAB DETAILS (SPECIAL)

DESIGNED: JAW
CHECKED: BTO
DRAWN: BTO
CHECKED: JAN
DATE: 4/06