

TANGENT SECTION
 STA. 302+97 TO STA. 306+26 LT (A)
 STA. 303+66 TO STA. 306+26 RT (A)

*** CONCRETE MEDIAN SURFACE BEGINS AT STA. 305+62 AND RUNS ADJACENT TO THE CORRUGATED MEDIAN TO STA. 306+26

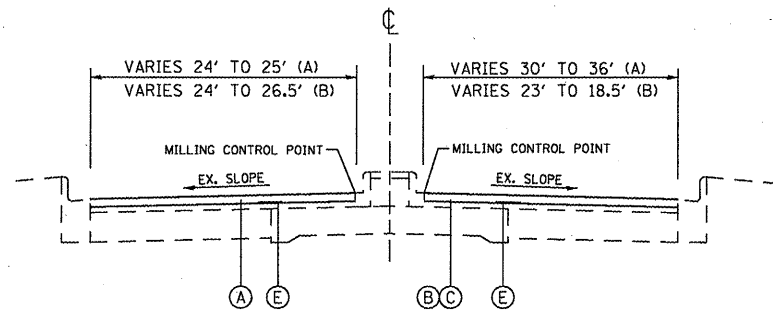

TANGENT SECTION
 STA. 306+15 TO STA. 312+96 (A)
 STA. 312+96 TO STA. 315+82 (B)

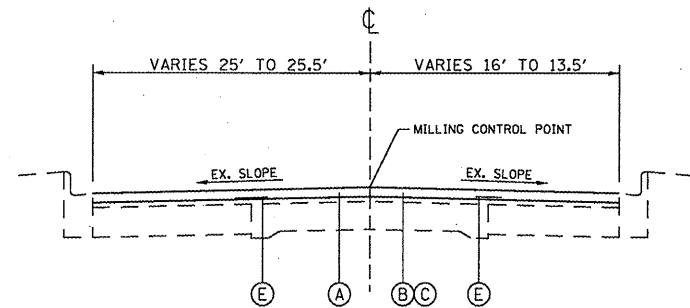

TANGENT SECTION
 STA. 315+82 TO STA. 317+72

- LEGEND**
- (A) PROPOSED HMA SURFACE REMOVAL, 2 1/4"
 - (B) PROPOSED POLYMERIZED HMA SURFACE COURSE, MIX "D", N90, 1 1/2"
 - (C) PROPOSED LEVELING BINDER (MACHINE METHOD), N90, 3/4"
 - (D) PROPOSED AGGREGATE SHOULDER, TYPE B, 2"
 - (E) PROPOSED STRIP REFLECTIVE CRACK CONTROL TREATMENT
 - (F) PROPOSED HMA SHOULDERS, 8"

FILE NAME =	USER NAME = #USER#	DESIGNED -	REVISED -
#FILE#		DRAWN -	REVISED -
	PLOT SCALE = #SCALE#	CHECKED -	REVISED -
	PLOT DATE = #DATE#	DATE -	REVISED -

STATE OF ILLINOIS
 DEPARTMENT OF TRANSPORTATION

PROPOSED TYPICAL SECTIONS

F.A.P. RTE.	SECTION	COUNTY	TOTAL SHEETS	SHEET NO.
594	(61-63)RS-3	MADISON	40	11
FED. ROAD DIST. NO. ILLINOIS FED. AID PROJECT			CONTRACT NO. 76B71	
SCALE: _____	SHEET NO. 4 OF 4 SHEETS	STA. _____ TO STA. _____		