

F.A.S. RFE.	SECTION	COUNTY	TOTAL SHEETS	SHEET NO.
608	97-00043-01-FP	SCOTT	17	3
STA.		TO STA.		
FED. ROAD DIST. NO.		ILLINOIS	PROJECT NO SR-0608(109)	

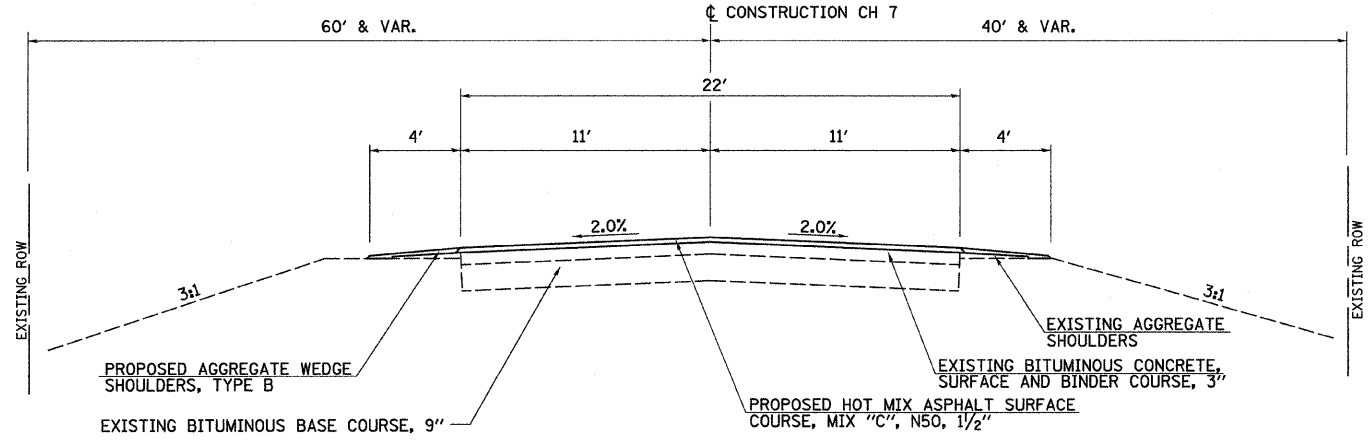

PROPOSED TYPICAL SECTION
STA 0+14.19 TO STA 12+17.06

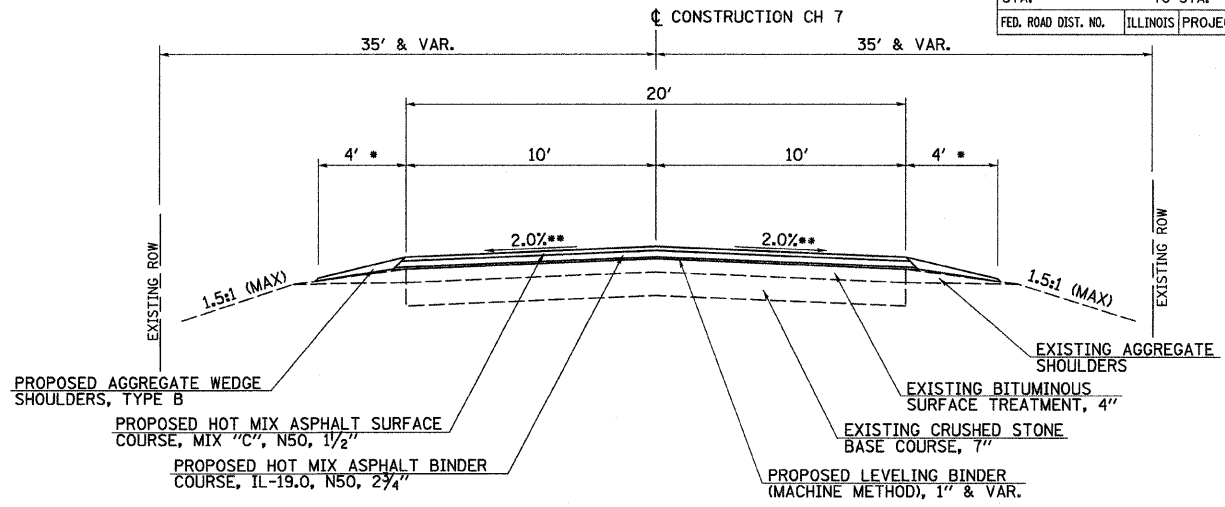

PROPOSED TYPICAL SECTION

STA 12+17.06 TO STA 14+63.62
 STA 21+67.13 TO STA 86+47.05
 STA 89+74.79 TO STA 158+86.76
 STA 172+35.47 TO STA 177+69.58

STA 188+87.22 TO STA 219+73.24
 STA 233+87.65 TO STA 241+82.98
 STA 251+51.46 TO STA 253+12.60
 STA 260+71.12 TO STA 262+33.00

•• OR SUPERELEVATION RATE

• REDUCE SHOULDER WIDTH TO 2' FROM STA 121+00 TO STA 137+00 IN GLASGOW

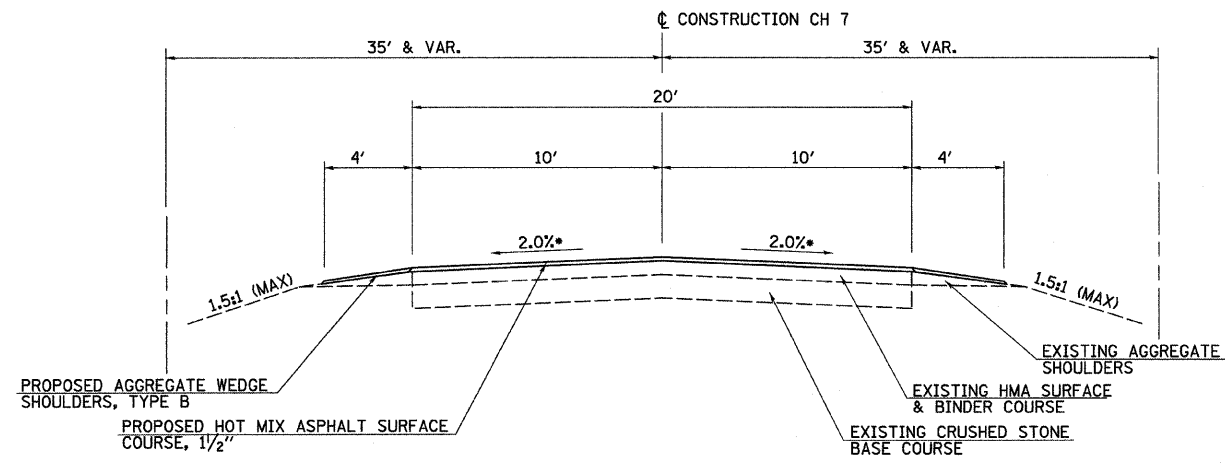

PROPOSED TYPICAL SECTION
STA 262+33.00 TO STA 270+51.77
• OR SUPERELEVATION RATE

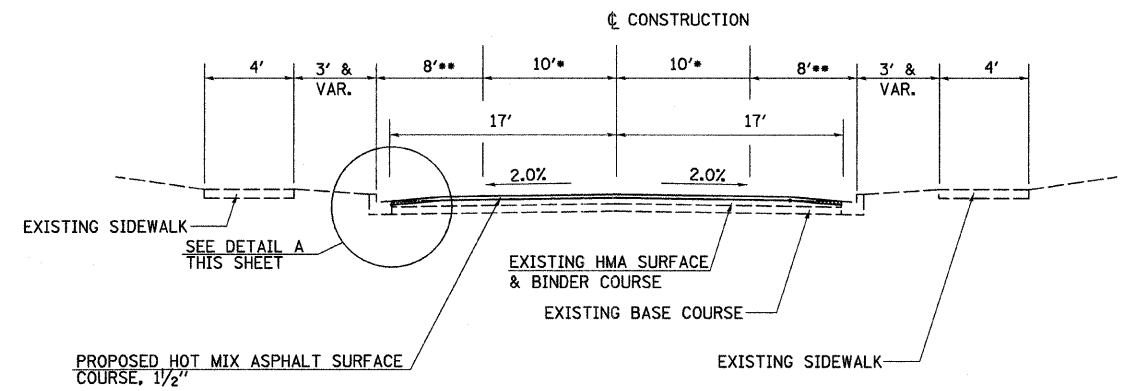

EXISTING TYPICAL SECTION
STA 270+51.77 TO STA 295+33.72 (THRU ALSEY)

• TRAFFIC LANE
•• PARKING LANE

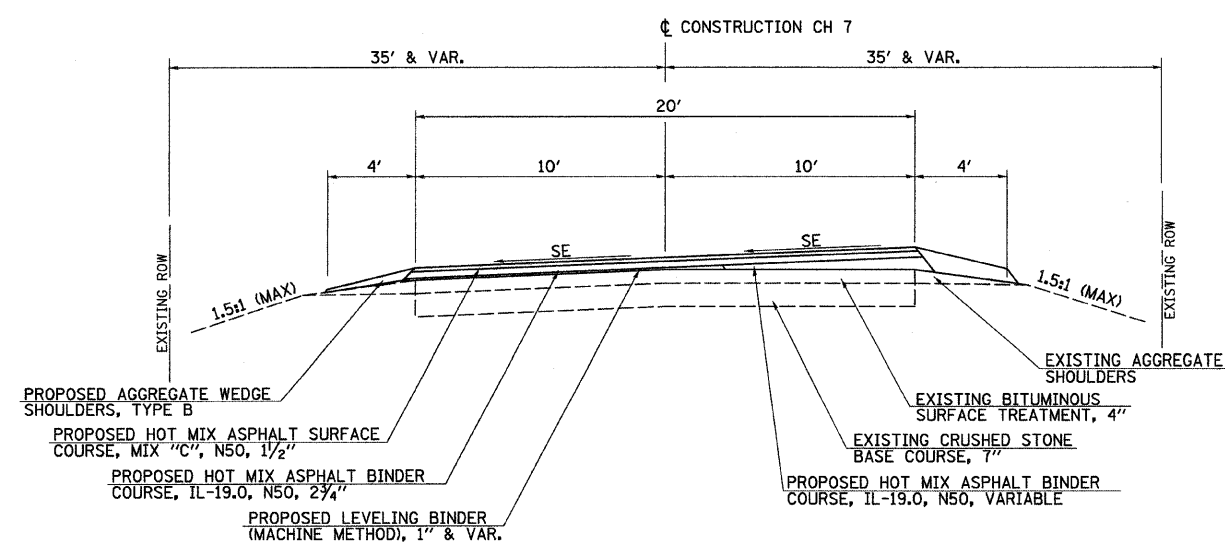

PROPOSED TYPICAL SECTION

STA 14+63.62 TO STA 21+67.13 (CURVE LEFT)
 STA 86+47.05 TO STA 89+74.79 (CURVE LEFT)
 STA 158+86.76 TO STA 172+35.47 (CURVE LEFT)
 STA 177+69.58 TO STA 188+87.22 (CURVE RIGHT)

STA 219+73.24 TO STA 233+87.65 (CURVE LEFT)
 STA 241+82.98 TO STA 251+51.46 (CURVE LEFT)
 STA 253+12.60 TO STA 260+71.12 (CURVE RIGHT)

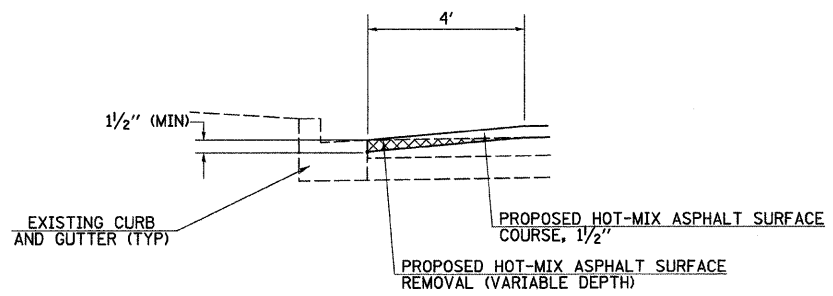

DETAIL A (TYP)

NOTES: SEE CURVE DATA ON PLAN SHEETS FOR SUPERELEVATION RATES AND TRANSITION LENGTHS.
 TYPICAL SHOULDER SLOPE IS 6% WITH MAXIMUM SHOULDER ROLLOVER FACTOR NOT TO EXCEED 12%.

REVISIONS	
NAME	DATE

ILLINOIS DEPARTMENT OF TRANSPORTATION
PROPOSED TYPICAL SECTIONS
 COUNTY HIGHWAY 7

SCALE: DATE: MARCH, 2008
 DRAWN BY: CHECKED BY:

PLOT DATE = 3/9/2009
 FILE NAME = W:\2438\COMBINED PLANS\2438.dwg
 PLOT SCALE = 8.9982 / IN.
 USER NAME = bbergman