

STATE OF ILLINOIS
DEPARTMENT OF TRANSPORTATION

ROUTE NO.	SECTION	COUNTY	TOTAL SHEETS	SHEET NO.
TR 438	04-19123-00-BR	FAYETTE	13	9
FED. ROAD DIST. NO.	ILLINOIS	PROJECT		

CONTRACT NO. 95567

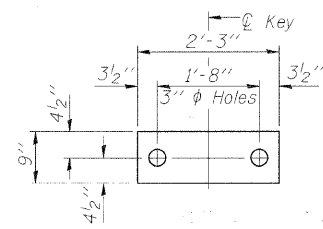

FABRIC BEARING PAD
(Interior)

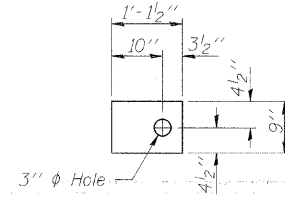

FABRIC BEARING PAD
(Exterior)

FIXED

Note: Omit holes when using expansion bearings.

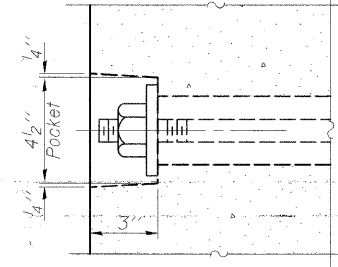

SECTION A-A

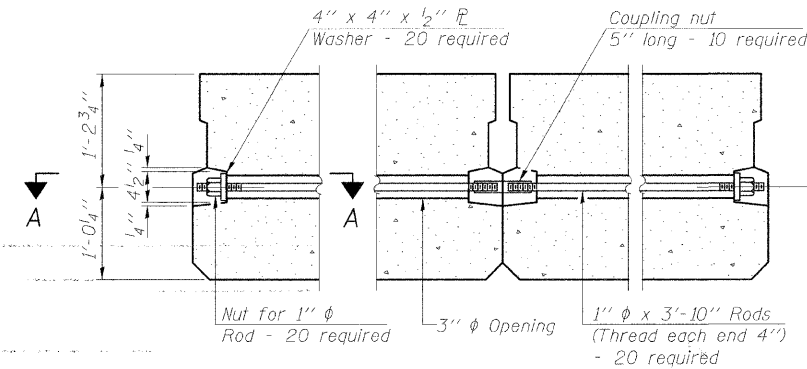

TYPICAL TRANSVERSE TIE ASSEMBLY

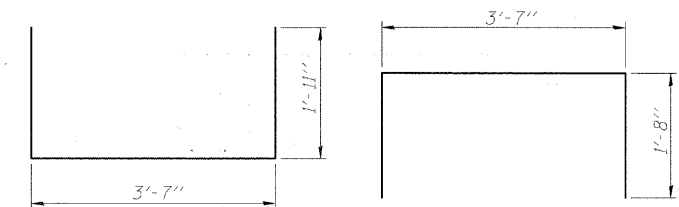

BAR S(E)

BAR S₁(E)

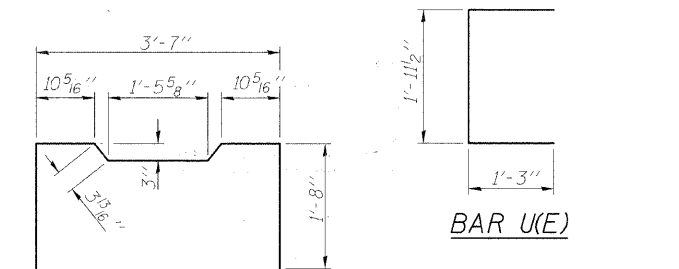

BAR S₂(E)

BAR U(E)

BAR U₁(E)

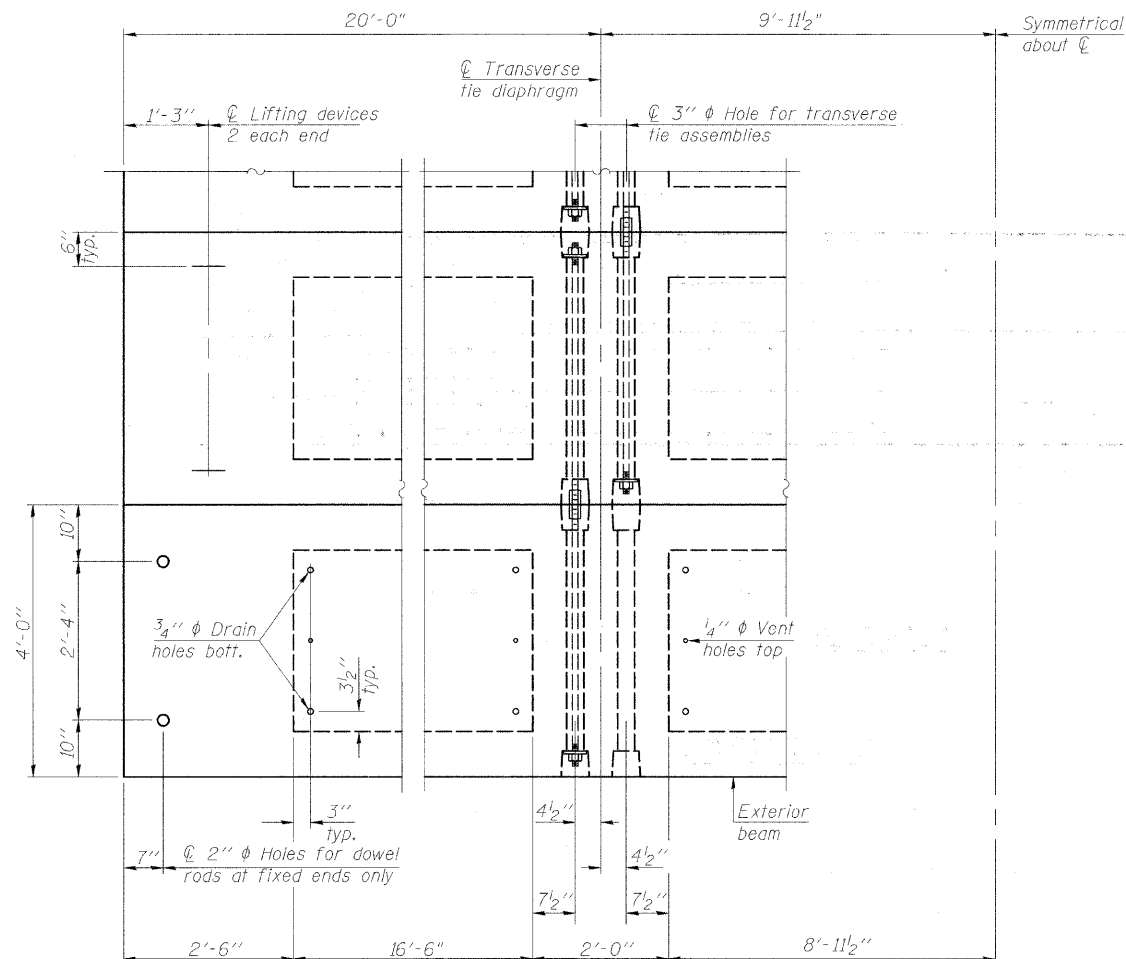

PLAN VIEW

Note: Connect beams in pairs with the transverse tie configuration shown.

NOTES

- Prestressing steel shall be uncoated high strength, low relaxation 7-wire strand, Grade 270. The nominal diameter shall be 1/2" and the nominal cross-sectional area shall be 0.153 sq. in.
- The 1" rods in the transverse tie assembly shall be tightened to a snug fit and the threads set. Pockets on exterior faces of bridge shall be filled with grout after transverse tie assembly is in place.
- Reinforcement bars shall conform to ASTM A 706, Grade 60. (See Special Provisions).
- Two 1/8" fabric adjusting shims of the dimensions of the exterior bearing pad shall be provided for each bearing pad location.
- Corrosion Inhibitor, per Article 1020.05(b)(12) and 1021.06 of the Standard Specifications, shall be used in the concrete for precast prestressed concrete deck beams.
- Compressive strength of prestressed concrete, f'_c , shall be 6000 psi.
- Compressive strength of prestressed concrete at release, f'_{ci} , shall be 5000 psi.
- Rail post anchor devices shall be cast into outside beam as elsewhere specified.
- Keyway surfaces shall be cleaned to remove form oil or other bond breaking material prior to shipment of the beams. Cleaning shall be done by sandblasting the keyway areas between the top of the beam and the bottom edge of the key.

DESIGN STRESSES

- $f'_s = 270,000$ p.s.i. (1/2" ϕ Strand)
- $f'_{si} = 201,960$ p.s.i. (1/2" ϕ Strand)
- $F_t = 30,900$ lbs per strand
- $f_y = 60,000$ p.s.i. Reinf. bars
- $f'_c = 6,000$ p.s.i.
- $f'_{ci} = 5,000$ p.s.i.

Note: See sheet SLM-CS-2427-60 for Bill of Material.



SLM-PD-2748-0D
P.P.C. DECK BEAM
DETAILS AND NOTES
24' ROADWAY
27" x 48" BEAMS
0° SKEW