

\* 163 (034)  
\*\* 97377

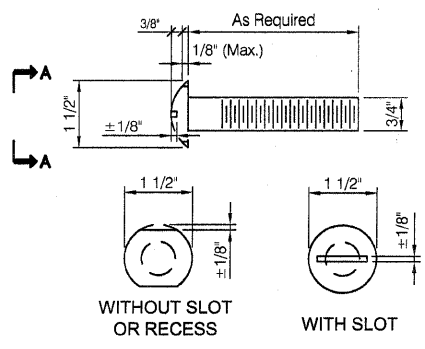

VIEW A-A  
ROUND HEAD BOLT

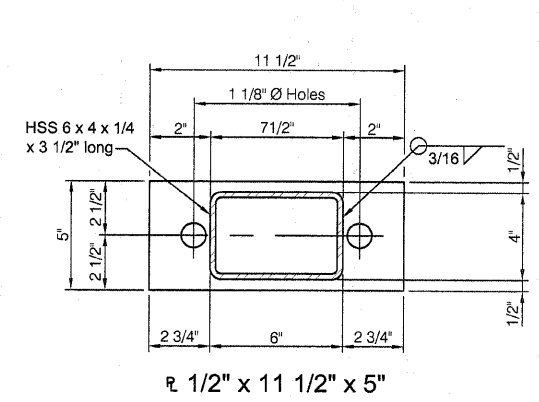

1/2" x 11 1/2" x 5"

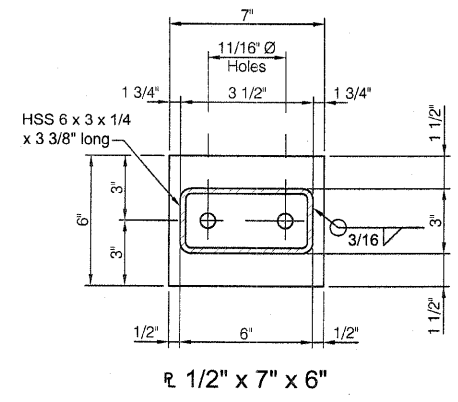

1/2" x 7" x 6"

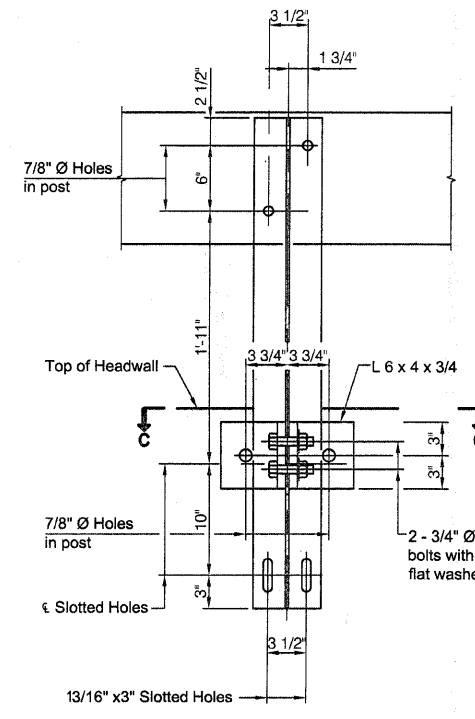

SECTION B-B

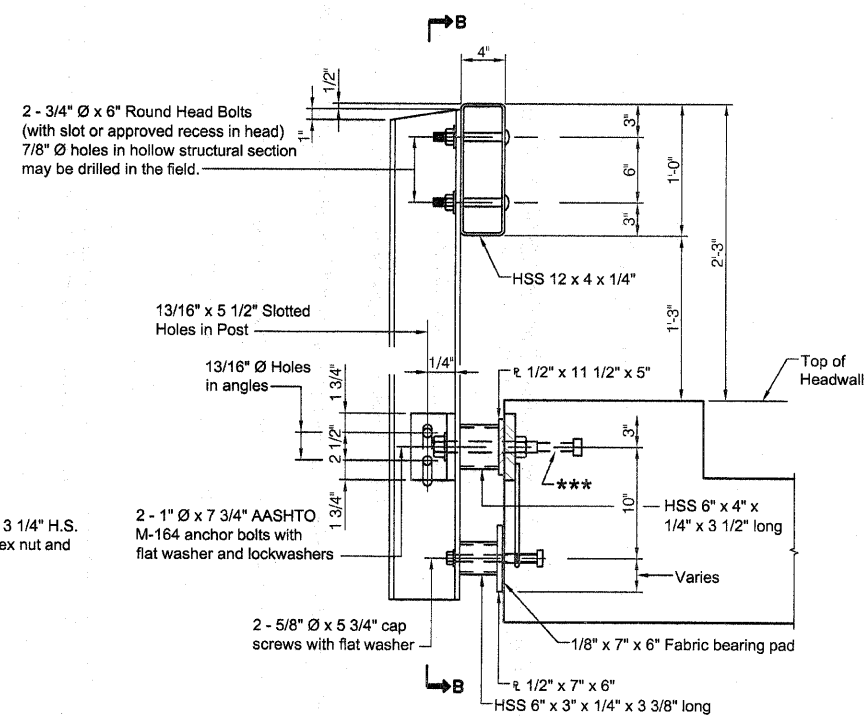

SECTION AT RAILING POST

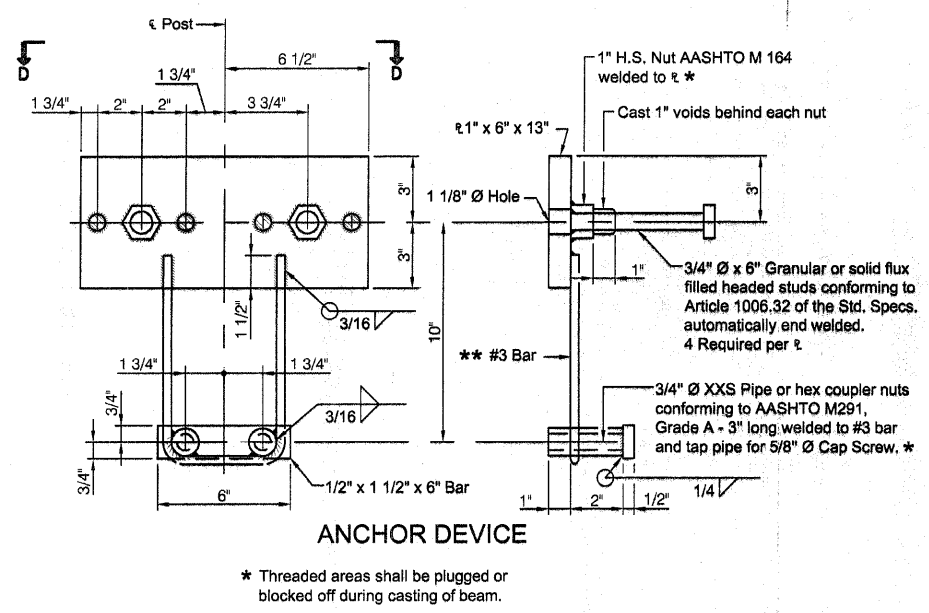

ANCHOR DEVICE

Notes:  
All field drilled holes shall be coated with an approved zinc rich paint before erection.  
For multi-span bridges, sufficient 1/4" x 6" x 1'-2" galvanized steel shims shall be provided to align rail between adjacent spans. Cost included with Steel Railing, Type S-1.  
All steel rail elements shall be galvanized according to Article 509.05 of the Standard Specifications.  
\*\*\* The studs of the anchor devices shall be placed below the top reinforcement bars and the outermost longitudinal reinforcement bar shall be placed directly above the studs of the rail post anchor device.

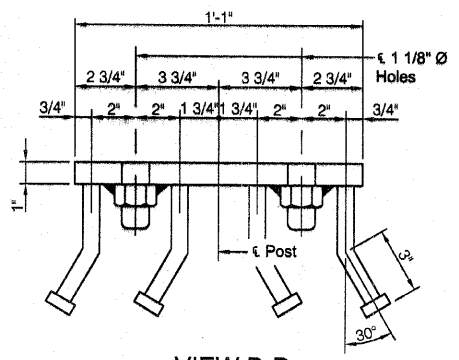

VIEW D-D

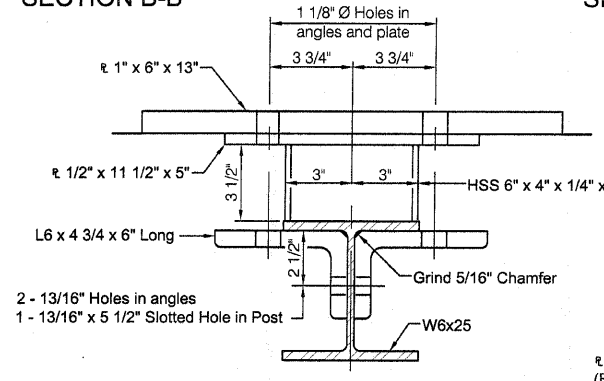

SECTION C-C

\*\*\* Whenever the lower insert assemblies interfere with strand locations, the #3 bars shall be cut and adjusted in order to allow raising or lowering of the lower inserts. Maximum adjustment not to exceed 1/2\".

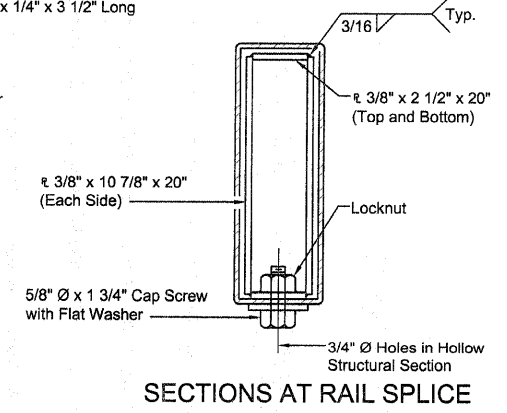

SECTIONS AT RAIL SPLICE

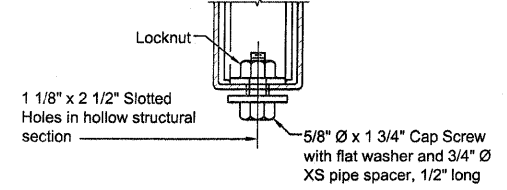

RAIL SPLICE CONNECTION AT EXPANSION JT.

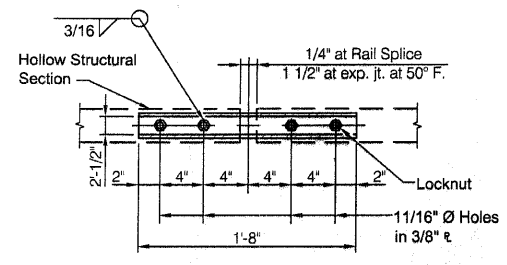

PLAN-BOTT. SPLICE TYPICAL

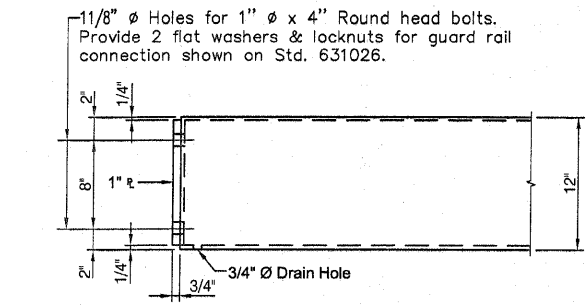

END OF RAIL DETAILS

BILL OF MATERIAL

Item	Unit	Quantity
Steel Railing, Type S-1	Foot	77

STEEL RAILING, TYPE S-1

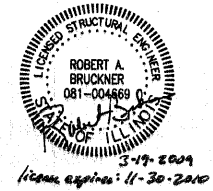

BRIDGE OVER DRY LAKE SOUGH  
STEEL RAILING, TYPE S1  
SAINT CLAIR COUNTY

	INITIALS	DATE
DESIGNED		
CHECKED		
DRAWN		
CHECKED		

