

F.A.P. RTE.	SECTION	COUNTY	TOTAL SHEETS	SHEET NO.
345	8R-1-N-1	COOK	196	10A
STA.	TO STA.			
FED. ROAD DIST. NO.	ILLINOIS	FED. AID PROJECT		
CONTRACT NO. 62617				

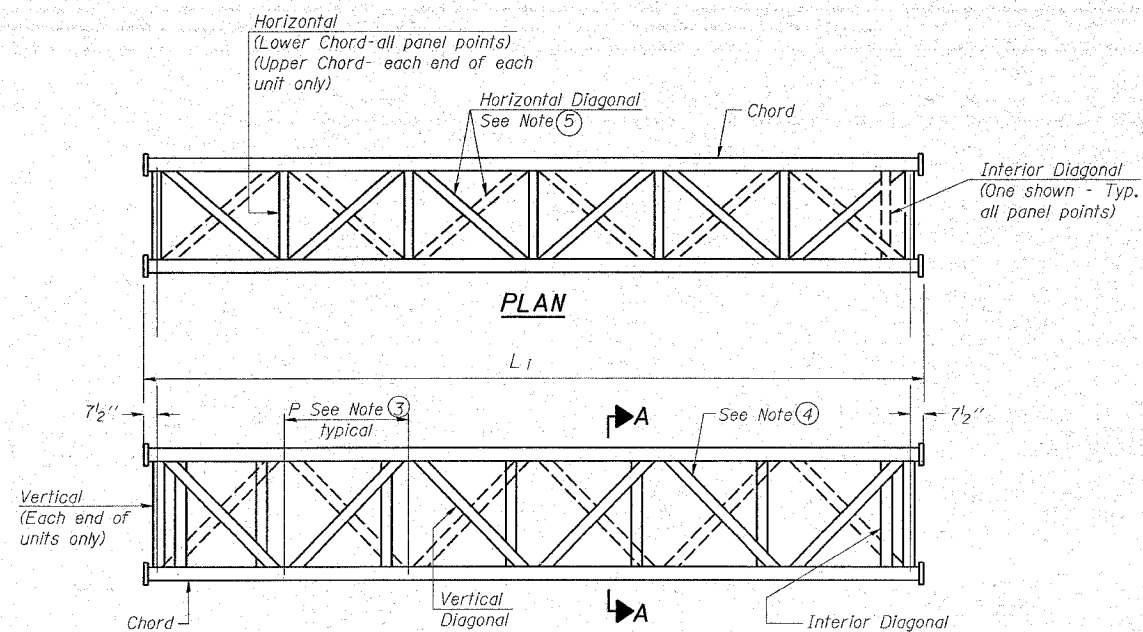

**ELEVATION
TYPICAL INTERIOR UNIT**

Even number of panels/interior unit required.

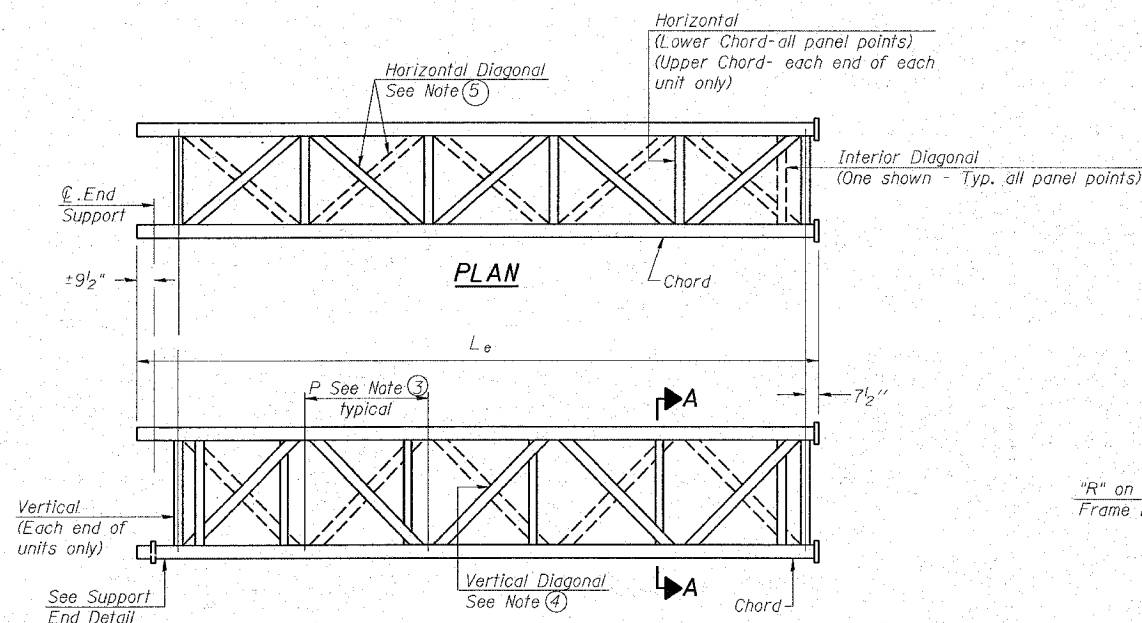

**ELEVATION
TYPICAL EXTERIOR UNIT**

Even or odd number of panels/exterior units allowed.

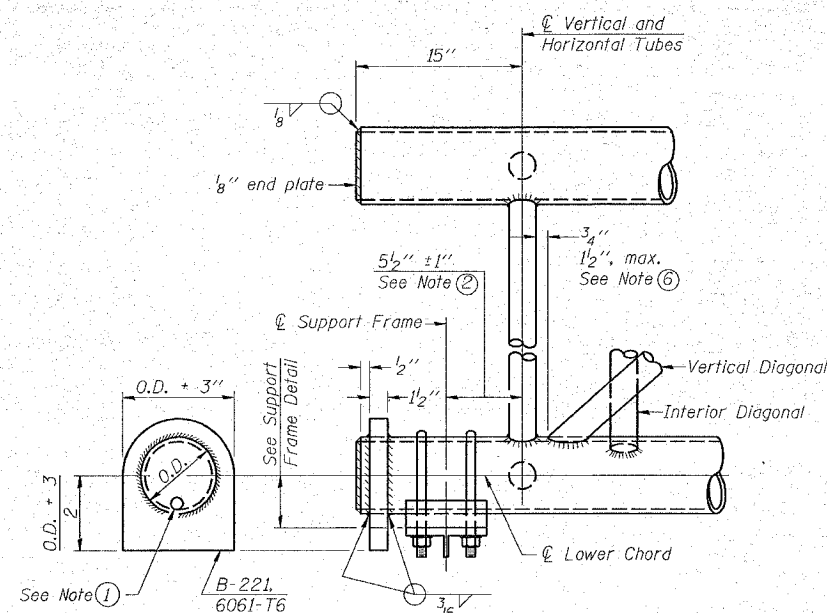

SUPPORT END DETAIL FOR EXTERIOR UNIT

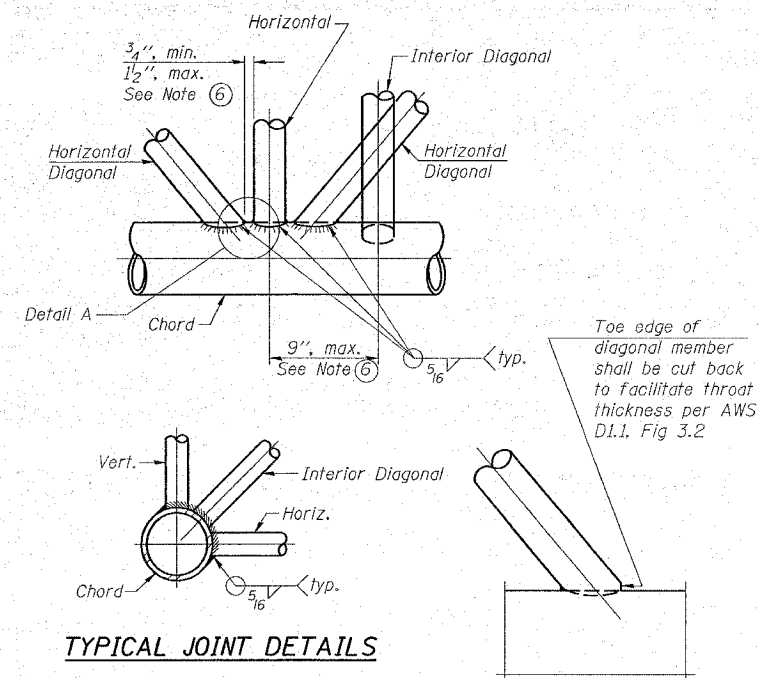

TYPICAL JOINT DETAILS

DETAIL A

NOTES

- Contractor may alternatively use standard aluminum drive-fit cap to close end. 1/2" φ drain hole in end plate/drive-fit cap. (Typ. at ends of all chords)
- 5 1/2" end dimension may vary by ±1" to provide uniform panel spacing (P).
- Panel spacing (P) shall be uniform for entire truss and between 4'-0" and 5'-0" for Type I-A or 4'-0" and 5'-6" for Types II-A and III-A.
- Vertical Diagonals in front and back face shall alternate.
- Hidden lines show wind bracing alternates direction between planes of top and bottom chords.
- All diagonals shall be detailed for minimum offset from the panel point based on the following: Offset shall be such as to provide a 3/4" minimum to 1 1/2" maximum clearance between any diagonal and any horizontal or vertical member, and to provide clearance for U-bolt connections of signs or walkway brackets.

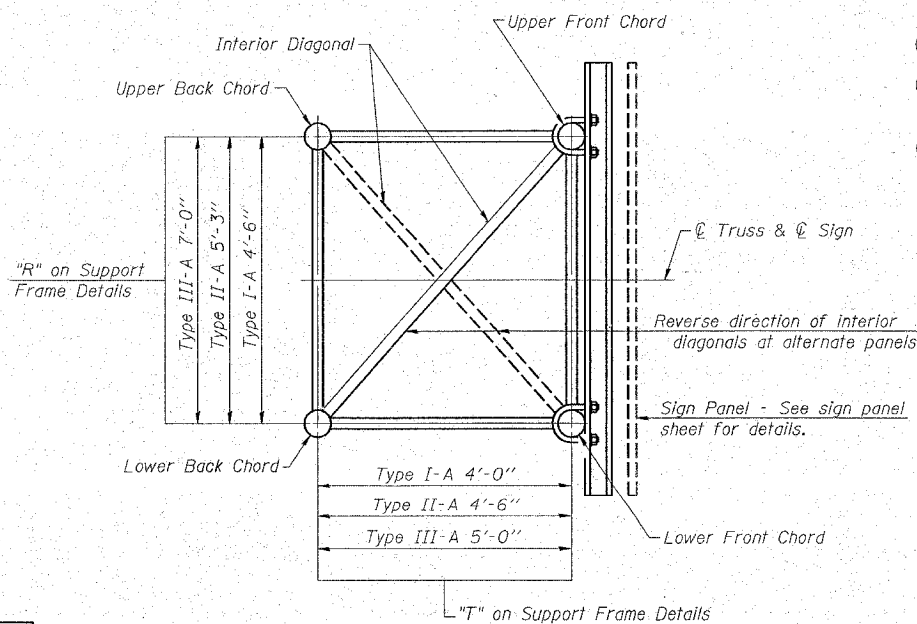

SECTION A-A

**OVERHEAD SIGN STRUCTURES
ALUMINUM TRUSS DETAILS
FOR TRUSS TYPES I-A, II-A AND III-A**

US.20 AT SHALES PKWY.

NUMBER	REVISION	DATE

OS-A-2

6/01/2007

SCALE: VERT. N.T.S.
HORIZ. N.T.S.
DATE: 2/20/2008

DRAWN BY: JSN
DESIGNED BY: JSN
CHECKED BY: JOD