

F. A. P.E.	SECTION	COUNTY	TOTAL SHEETS	SHEET NO.
	08-00146-00-TL	COOK	273	034
STA.	TO STA.			
FED. ROAD DIST. NO.	ILLINOIS	FED. AID PROJECT		

CONTRACT NO. 63003

CABLE PLAN LEGEND

EXISTING	PROPOSED	
		8" TRAFFIC SIGNAL SECTION
		12" TRAFFIC SIGNAL SECTION
		12" PEDESTRIAN SIGNAL SECTION
		12" PEDESTRIAN SIGNAL SECTION
		CONTROLLER CABINET
		SERVICE INSTALLATION
		TELEPHONE CONNECTION
		MAGNETIC DETECTOR
		EMERGENCY VEHICLE LIGHT DETECTOR
		CONFIRMATION BEACON
		PUSHBUTTON DETECTOR
		VEHICLE DETECTOR, INDUCTION LOOP
		DENOTES NUMBER OF CONDUCTORS. ALL CABLE NO. 14 EXCEPT AS INDICATED. ALL LOOP DETECTOR CABLE TO BE SHIELDED.
		SIGNAL FACE WITH BACKPLATE
		"P" INDICATES PROGRAMMED HEAD
		RAILROAD CONTROL CABINET
		ILLUMINATED SIGN, FIBER OPTIC "NO LEFT TURN"
		ILLUMINATED SIGN, FIBER OPTIC "NO RIGHT TURN"
		H/C GROUND ROD AT HANDHOLE, DOUBLE HANDHOLE, OR CONTROLLER
		P GROUND ROD AT POST OR MAST ARM POLE
		S GROUND ROD AT ELECTRIC SERVICE INSTALLATION

CONTROLLER SEQUENCE IV  
REFERRING TO STANDARD 2393-1, THE VEHICULAR AND PEDESTRIAN PHASES USED ARE DESIGNATED BELOW.

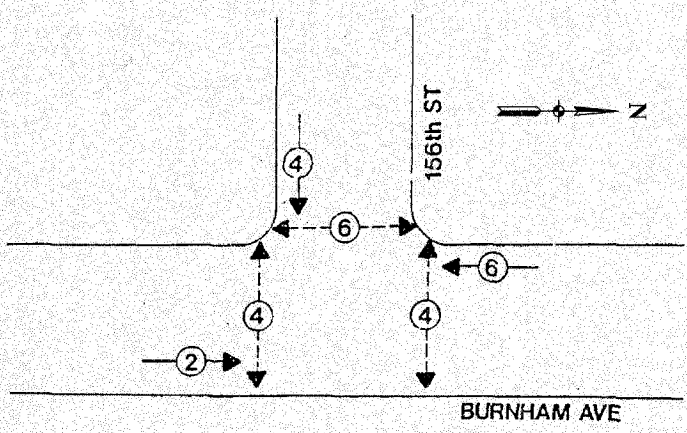

LEGEND  
 VEHICULAR MOVEMENT  
 PEDESTRIAN MOVEMENT  
 \* NUMBER REFERS TO ASSOCIATED PHASE

PHASE DESIGNATION DIAGRAM

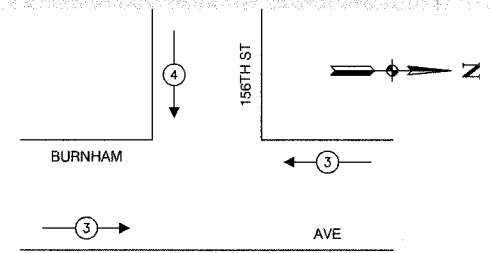

EMERGENCY VEHICLE PREEMPTION SEQUENCE

PROPOSED EMERGENCY VEHICLE PREEMPTORS		
EMERGENCY VEHICLE PREEMPTOR	3	4
MOVEMENT		

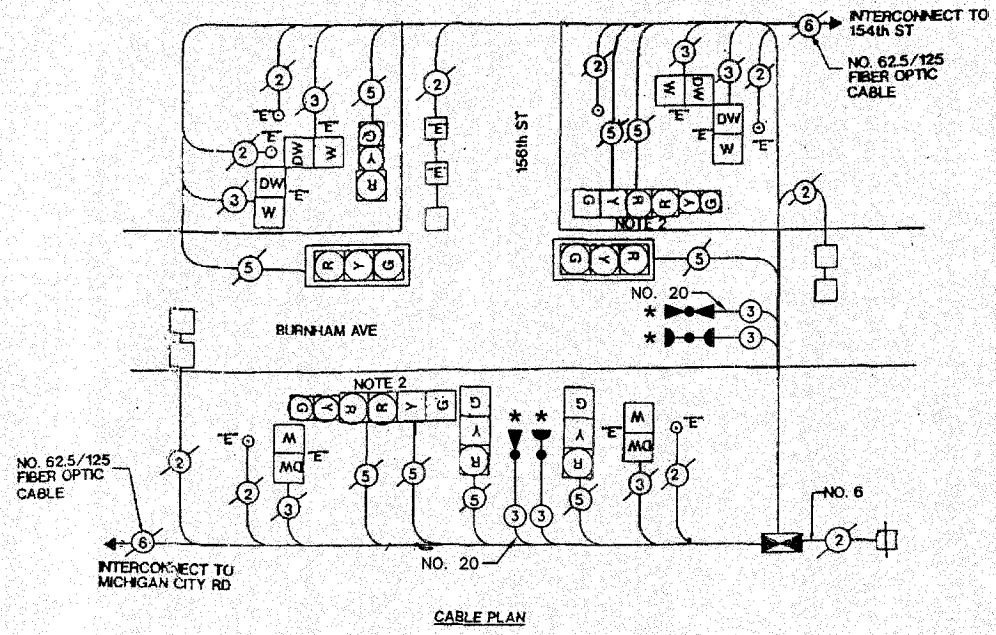

SCHEDULE OF QUANTITIES		
PAY ITEM	UNIT	QUANTITY
MAINTENANCE OF EXISTING TRAFFIC SIGNAL INSTALLATION	EACH	1
ELECTRIC CABLE IN CONDUIT, SIGNAL NO. 14 3C	FOOT	216
TRAFFIC SIGNAL POST, GALVANIZED STEEL 18 FT.	EACH	1
LIGHT DETECTOR	EACH	2
LIGHT DETECTOR AMPLIFIER	EACH	1
RELOCATE EXISTING SIGNAL HEAD	EACH	1
REMOVE AND REINSTALL ELECTRIC CABLE FROM CONDUIT	FOOT	15
REMOVE EXISTING TRAFFIC SIGNAL EQUIPMENT	EACH	1
ELECTRIC CABLE IN CONDUIT NO. 20 3/C, TWISTED, SHIELDED	FOOT	216

NOTE  
 \* 1. THIS PLAN IS FOR THE PURPOSE OF INSTALLING EMERGENCY VEHICLE PREEMPTION EQUIPMENT AS SHOWN PER PLAN INDICATED IN THE SCHEDULE OF QUANTITIES. ALL OTHER EQUIPMENT SHOWN SHALL BE DISREGARDED.

\* PLANS MODIFIED BY  
ROBINSON ENGINEERING, LTD.

REVISIONS	
NAME	DATE
ADDED EV PREEMPTION NEW 18' POST	01/02/08

CITY OF CALUMET CITY  
LOCATION NO. 8

ILLINOIS DEPARTMENT OF TRANSPORTATION

PROPOSED EMERGENCY VEHICLE PREEMPTION CABLE PLAN, PHASE DESIGNATION DIAGRAM & SCHEDULE OF QUANTITIES  
BURNHAM AVENUE & 156TH STREET

SCALE: VERT. \_\_\_\_\_  
HORIZ. \_\_\_\_\_

DATE \_\_\_\_\_ DRAWN BY \_\_\_\_\_  
CHECKED BY \_\_\_\_\_

ROBINSON ENGINEERING, LTD.  
17000 SOUTH PARK AVENUE SOUTH HOLLAND, ILLINOIS 60473  
708/313-8100 FAX 708/313-8188  
ILLINOIS DESIGN FIRM REGISTRATION NO. 184001228