

MAST ARM NORTHWEST QUADRANT (A)

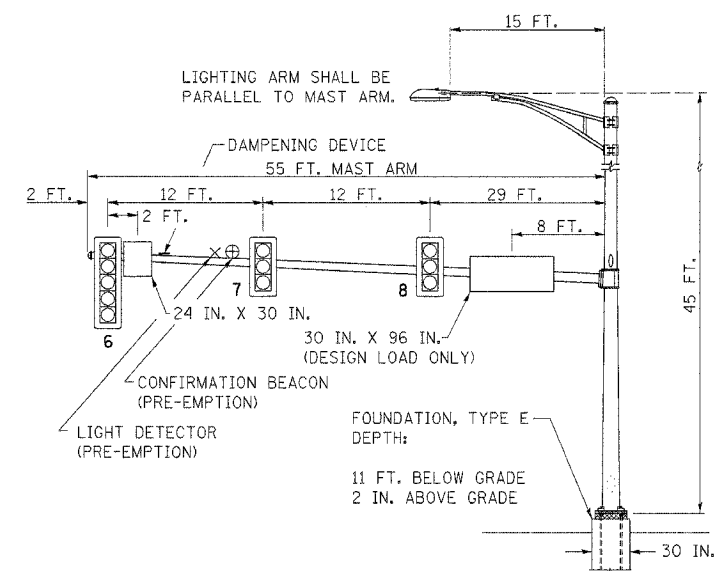

MAST ARM NORTHEAST QUADRANT (B)

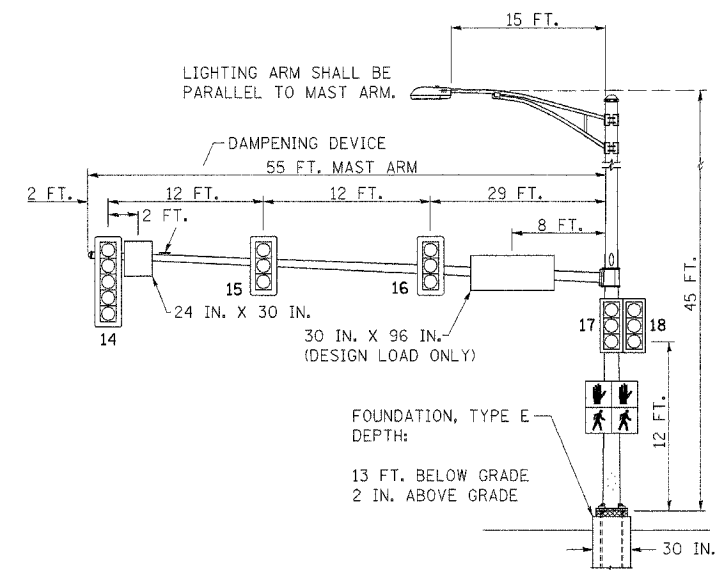

MAST ARM SOUTHWEST QUADRANT (C)

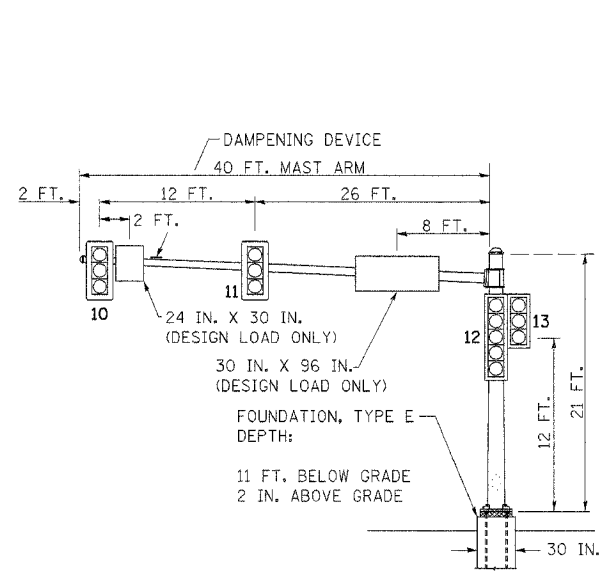

MAST ARM SOUTHEAST QUADRANT (D)

ELECTRICAL LOAD CHART

IL ROUTE 47			
INDICATION	NUMBER	WATTAGE EACH	BURN TIME (%)
RED	11	12	60
YELLOW	11	32	5
GREEN	11	12	35
YELLOW ARROW	4	12	5
GREEN ARROW	4	11	10
↑	4	7	5
↓	4	7	95

BENTON STREET			
INDICATION	NUMBER	WATTAGE EACH	BURN TIME (%)
RED	11	12	70
YELLOW	11	32	5
GREEN	11	12	25
↑	4	7	5
↓	4	7	95

TRAFFIC SIGNAL CABINET			
ITEM	NUMBER	WATTAGE EACH	BURN TIME (%)
CONTROLLER	1	6	100
INDUCTIVE LOOP DETECTOR UNINTERRUPTABLE POWER SUPPLY	10	1.5	100
LIGHT DETECTOR AMPLIFIER	1	50	100
	1	1.5	100

HIGHWAY LIGHTING			
ITEM	NUMBER	WATTAGE EACH	BURN TIME (%)
CONTROLLER	1	6	100
LUMINAIRE	2	250	45

DETECTOR LOOP INDUCTANCE CHART

DETECTOR LOOP SYSTEM	TURNS PER LOOP	INDUCTANCE READING (MICROHENRIES)	FREQUENCY (HERTZ)	J PIN STATUS
A	4	304	36004	OFF
B	5	290	36839	ON
C	4	470	28152	ON
D	4	884	38295	OFF
E	4	404	30365	ON
F	4	254	38295	OFF
G	5	268	37281	ON
H	4	404	30365	ON
I	4	884	38295	OFF
J	4	680	29570	ON

STREET SIGN DETAIL

THESE STREET NAME SIGNS SHALL BE PLACED ON THE MAST ARMS PARALLEL TO THE RESPECTIVE ROUTE AS DIRECTED BY THE ENGINEER.

STREET NAME SIGNS:
 1. TYPE A SHEETING REQUIRED
 2. WHITE/GREEN BACKGROUND
 3. STYLE (d) - 5/8 IN. BORDER
 4. 8 IN. SERIES D LETTERS
 5. ALL DIMENSIONS ARE IN INCHES UNLESS OTHERWISE SHOWN

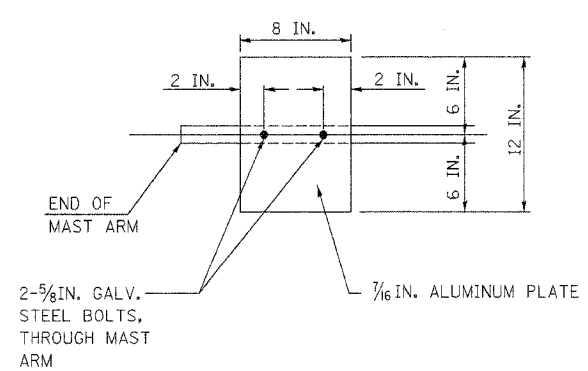
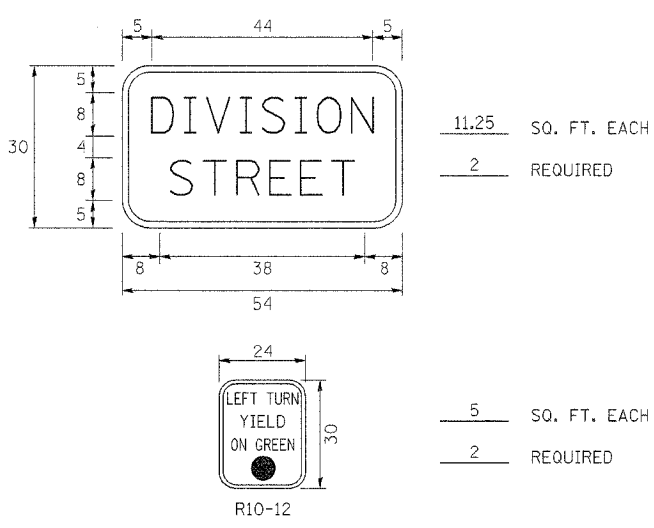
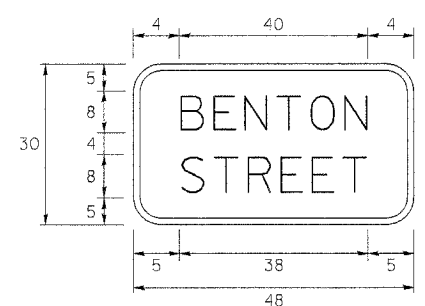

DAMPENING PLATE DETAIL (TOP VIEW) INCIDENTAL TO MAST ARM QUANTITY

PEDESTRIAN CROSSING SIGN DETAIL

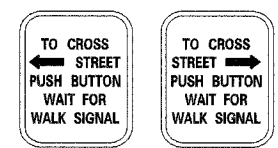

R10-4a LEFT OR RIGHT
8 REQUIRED

DIMENSIONS: 9 IN. x 12 IN. (TYP.)
 LEGEND AND BORDER: NON-REFLECTORIZED BLACK
 BACKGROUND: NON-REFLECTORIZED WHITE

ONE SIGN SHALL BE PROVIDED FOR EACH PUSH-BUTTON. ORIENTATION OF DIRECTIONAL ARROWS TO BE DETERMINED BY PUSH-BUTTON LOCATION.

ALL MOUNTING HARDWARE SHALL BE STAINLESS STEEL CONSTRUCTION. ALL MOUNTING BOLTS SHALL BE HEX HEAD.

MATERIALS AND INSTALLATION OF THIS SIGN SHALL BE INCLUDED IN THE COST OF PEDESTRIAN PUSH-BUTTON.

REVISIONS	
NAME	DATE

ILLINOIS DEPARTMENT OF TRANSPORTATION
 MAST ARM LOADING DIAGRAM
 ELECTRICAL LOAD CHART
 SIGN DETAILS
 IL. 47 (DIVISION ST.) /
 BENTON STREET

SCALE: NONE DRAWN BY: JVR
 DATE: JANUARY 2008 CHECKED BY: FML