

F.A.D. RTE.	SECTION	COUNTY	TOTAL SHEETS	SHEET NO.
313	(21-HB-I)I	Knox		17C
FED. ROAD DIST. NO.		ILLINOIS FED. AID PROJECT		
CONTRACT NO. 68216				

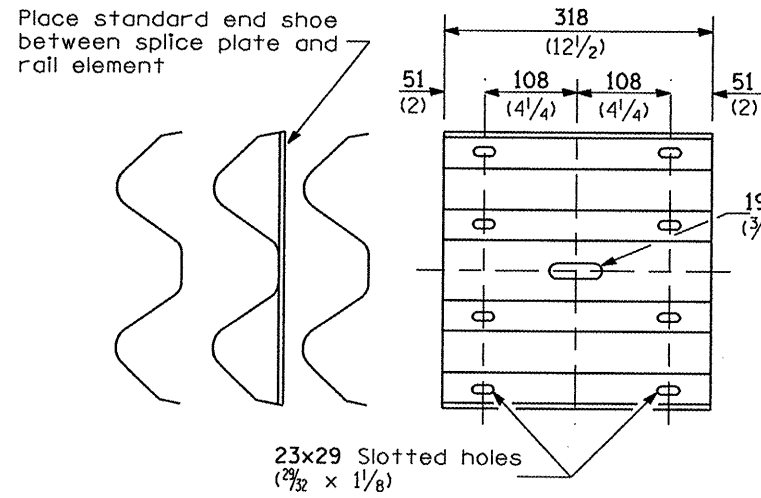

**SPLICE PLATE**

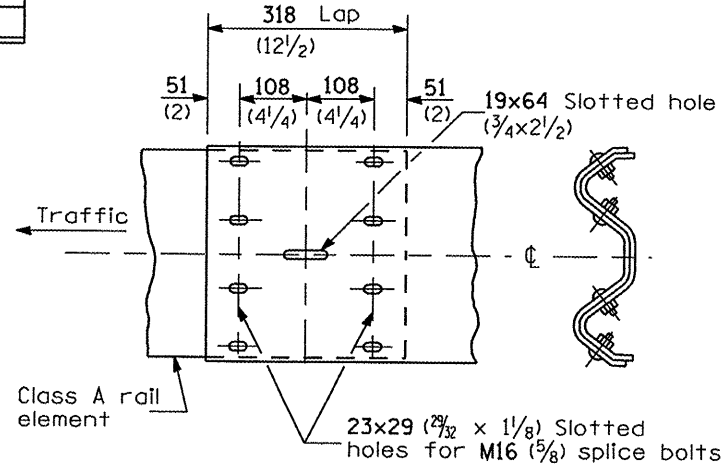

**RAIL ELEMENT SPLICE**

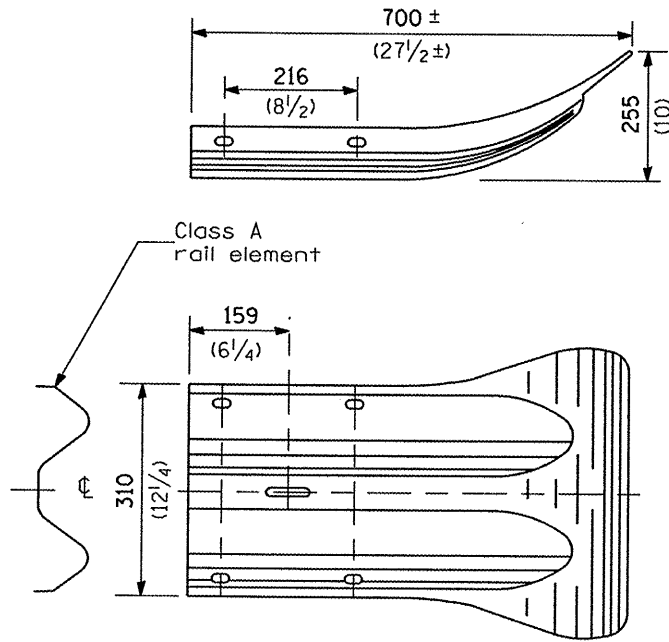

**END SECTION**

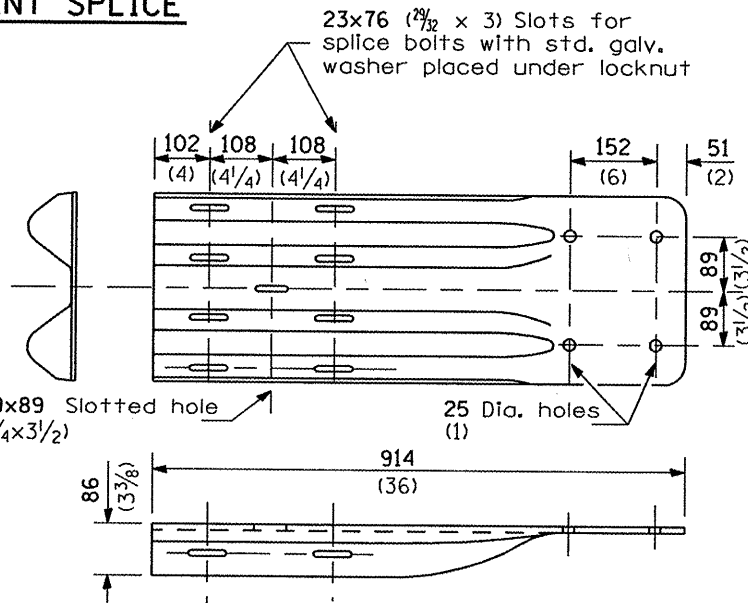

NOTE

When end shoe is attached to a bridge parapet which has an expansion joint, the bolts shall be provided with a locknut or double nut and shall be tightened only to a point that will allow guardrail movement.

The standard end shoe shall be attached to the concrete with pre-drilled or self-drilling anchor bolts. The anchor cone shall be set flush with the surface of the concrete.

Externally threaded studs protruding from the surface of the concrete will not be permitted.

**END SHOE**

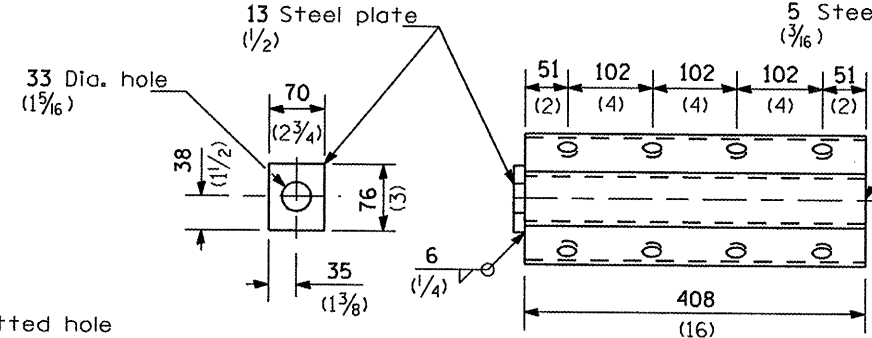

NOTE

Anchor plate T shall be used to attach cable assembly to guardrail when required on traffic barrier terminals.

**ANCHOR PLATE T DETAILS**

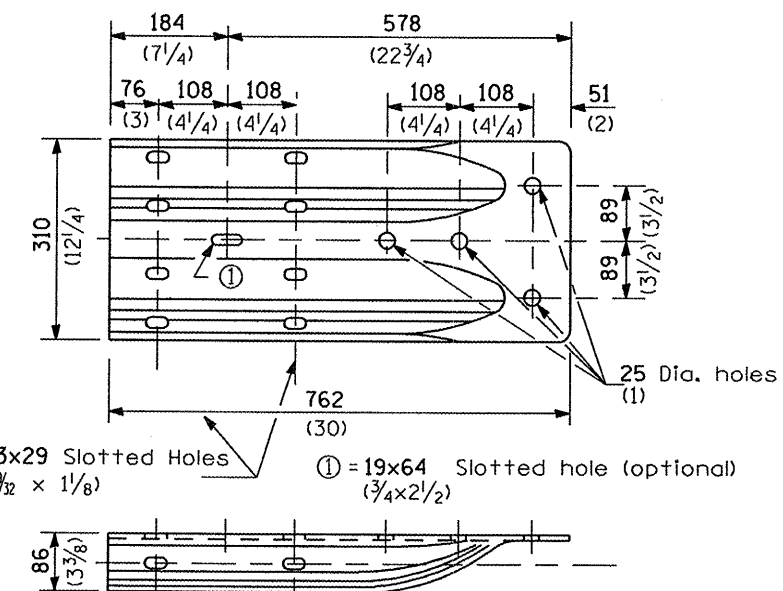

**ALTERNATE END SHOE**

**REMOVE AND REERECT  
STEEL PLATE BEAM GUARDRAIL**  
(Sheet 3 of 4)  
**DETAIL**