

\* REDUCE TO 40 FEET (12.2 METERS) ON CENTER ON CURVES WHERE ADVISORY SPEEDS ARE 10 MPH (15 km/h) LOWER THAN POSTED SPEEDS.

\*\* DOUBLE LANE LINE MARKERS SHALL BE SPECIFIED AND SPACED AS SHOWN IN HIGHWAY STANDARD 781001 FOR MULTI-LANE DIVIDED AND UNDIVIDED HIGHWAYS.

**GENERAL NOTES:**

- Ⓑ TURN ARROW PAIRS SHALL BE PLACED AT 250' (75 m) INTERVALS AND SHALL BE EVENLY SPACED BETWEEN BOTH ENDS OF THE BIDIRECTIONAL LEFT TURN LANE.
- Ⓒ THE SOLID YELLOW PAVEMENT MARKINGS [2] SHOULD GENERALLY START OR END NEAR THE RADIUS POINT OF EACH STREET RETURN EXCEPT WHERE ONE OR BOTH ENDS WOULD INCLUDE STOP BARS.
- Ⓓ THE SKIP-DASH PAVEMENT MARKINGS [1] OR [7] SHOULD BE CENTERED BETWEEN BOTH ENDS OF EACH CITY BLOCK AND SHALL BE PLACED SO THEY LINE UP ACROSS FROM EACH OTHER. SEE EXAMPLE ON SHEET 2 OF 3.
- Ⓔ USE LARGE ARROW SIZE FOR BOTH RURAL AND URBAN LOCATIONS. (SEE LAST PAGE OF SECTION 780x FOR SYMBOLS TABLE)

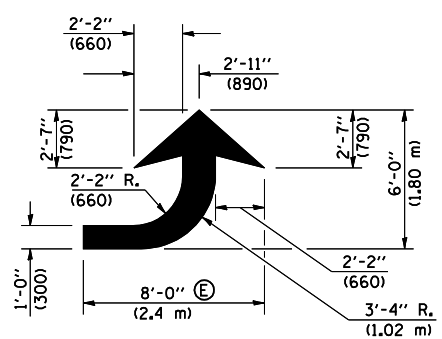

**LEFT ARROW**

REVERSE FOR RIGHT ARROW  
AREA = 15.6 SQ. FT. (1.47 m<sup>2</sup>)  
(WHITE)

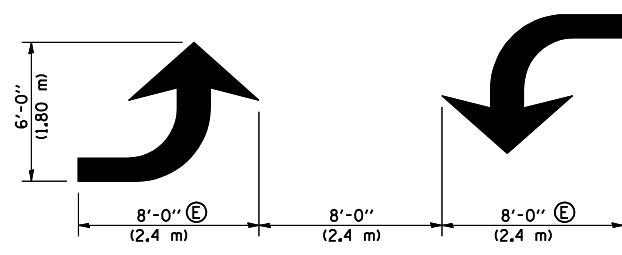

**TYPICAL DOUBLE TURN ARROWS (WHITE)**

**BLOOMINGTON-NORMAL CITY LIMITS ONLY**

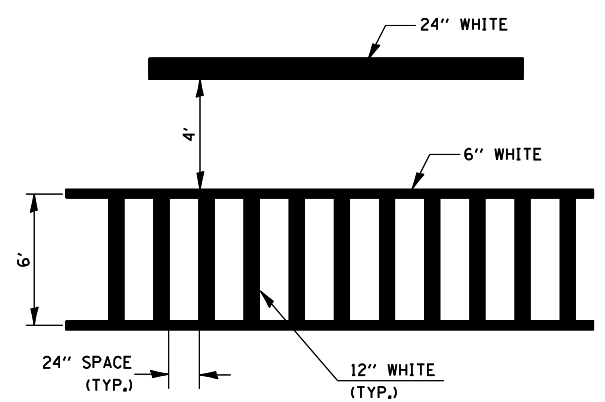

**TYPICAL SPACING FOR CROSSWALKS & STOP BARS**

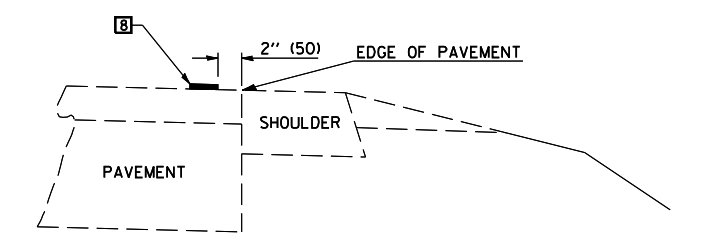
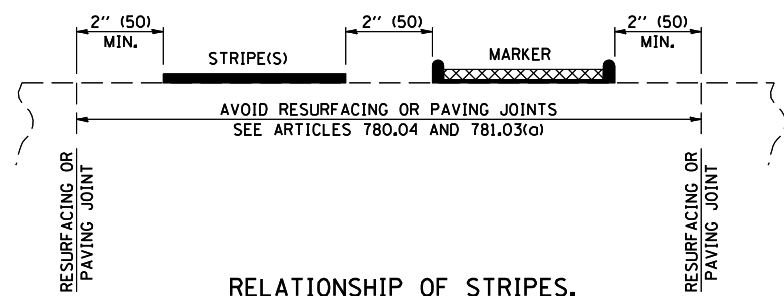

**RELATIONSHIP OF EDGE LINE TO EDGE OF PAVEMENT (SAFETY SHOULDER OR PAVED SURFACE) SEE ARTICLE 780.04**

Note: All dimensions are in INCHES (millimeters) unless otherwise shown.

**DISTRICT 5 DETAIL NO. 7800AAA**

FILE NAME =  
c:\projects\d502499 (v8)\typicals.dgn

USER NAME = collierbw  
PLOT SCALE = 40.0000' / IN.  
PLOT DATE = 3/12/2008

DESIGNED -  
DRAWN -  
CHECKED -  
DATE -

REVISED - 11/06  
REVISED -  
REVISED -  
REVISED -

**STATE OF ILLINOIS  
DEPARTMENT OF TRANSPORTATION**

**PAVEMENT MARKING AND MARKERS  
(RURAL & URBAN APPLICATIONS)**

SCALE: SHEET NO. 2 OF 4 SHEETS STA. TO STA.

F.A.P. RTE.	SECTION	COUNTY	TOTAL SHEETS	SHEET NO.
840	121BR-1	VERMILION	44	28
FED. ROAD DIST. NO. ILLINOIS FED. AID PROJECT			CONTRACT NO. 70018	