

STATE OF ILLINOIS
DEPARTMENT OF TRANSPORTATION

ROUTE NO.	SECTION	COUNTY	TOTAL SHEETS	SHEET NO.	SHEET NO. 7
F.A.S. 502	(86BR)BR	CHAMPAIGN	30	17	8 SHEETS
FED. ROAD DIST. NO. 7	ILLINOIS	FED. AID PROJECT-			

Contract # 70426

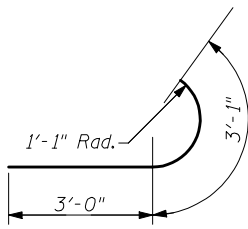

BAR $h_2(E)$

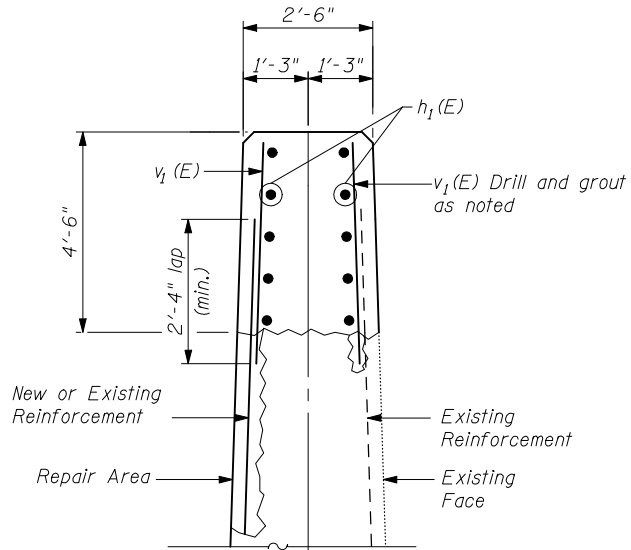

SHOWING NEW CAP ABOVE REPAIR AREA

SHOWING NEW CAP ABOVE NON-REPAIR AREA

SECTION C-C

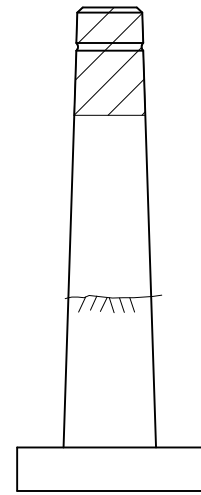

SOUTH

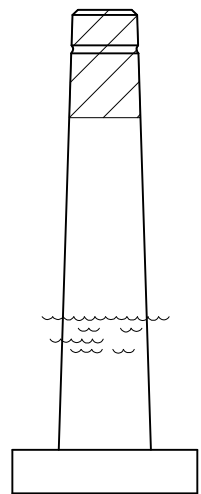

NORTH

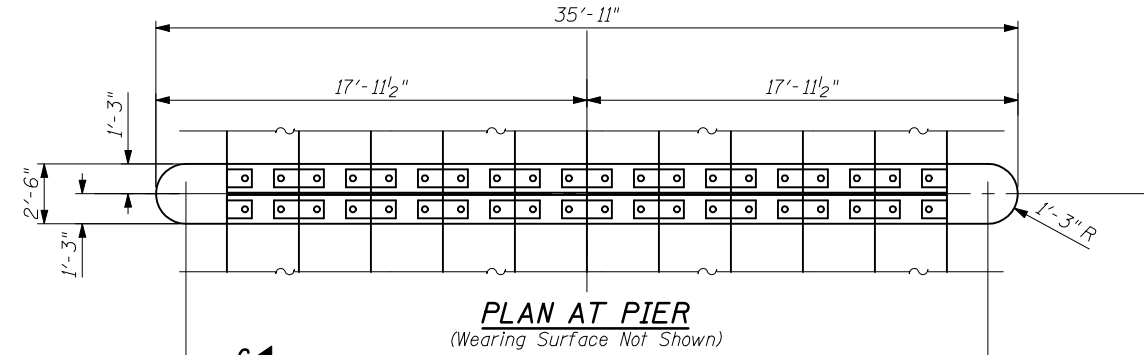

PLAN AT PIER
(Wearing Surface Not Shown)

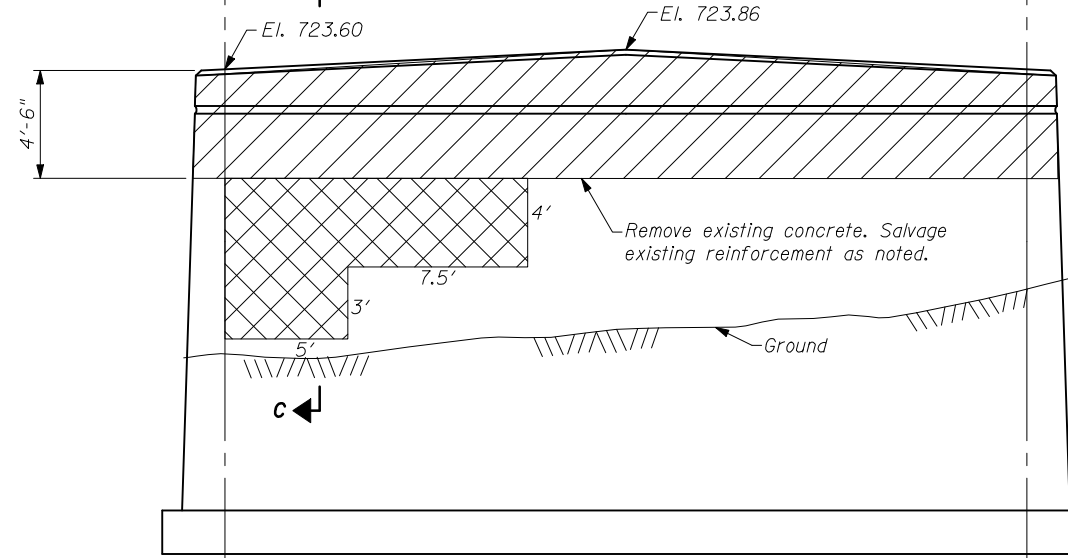

WEST FACE

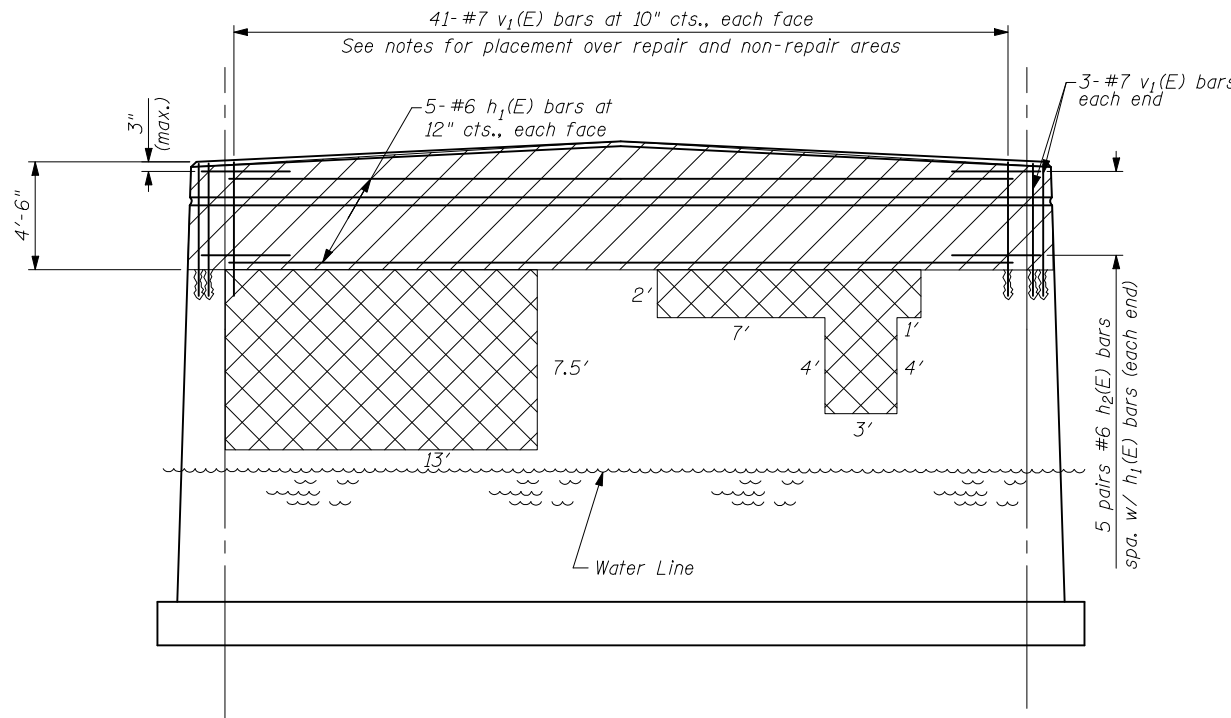

EAST FACE

NOTES:

For Section "B-B", see sheet 2 of 8.
Hatched areas indicate concrete removal. These areas to be poured after structural repair of concrete is complete for remainder of the pier.
For cap removal over non-repair areas, salvage existing #7 vertical bars. Bars to be cleaned, straightened, and incorporated into new construction. Cost included in cost of Concrete Removal.
For $v_1(E)$ bars in non-repair areas, place bars in 9" min. drilled holes in top of pier at removal limit. Place bars between salvaged vertical bars to remain. Epoxy grout according to Section 584 of the Standard Specifications. Cost included with cost of Reinforcement Bars, Epoxy Coated.
For cap removal over repair areas, evaluate the existing #7 vertical bars as outlined in the Structural Repair of Concrete Special Provision. Where new or supplemental reinforcing is provided lap splice the $v_1(E)$ bars to the new bars, otherwise lap splice the $v_1(E)$ bars to the existing reinforcement to remain.

BILL OF MATERIAL

Bar	No.	Size	Length	Shape
$h_1(E)$	10	#6	33'-5"	—
$h_2(E)$	20	#6	6'-2"	⌒
$v_1(E)$	88	#7	5'-1"	—
Concrete Removal		CU YD	16	
Concrete Structures		CU YD	16	
Reinforcement Bars, Epoxy Coated		POUND	1600	
Structural Repair of Concrete (Depth Less Than or Equal to 5")		SQ FT	216	

PIER 1 REPAIR DETAILS
LEVERETT ROAD OVER THE SALINE BRANCH
CHAMPAIGN COUNTY
F.A.S. ROUTE 502 - SEC. (86BR) BR
STATION 71+38.50
S.N. 010-0237

LEGEND

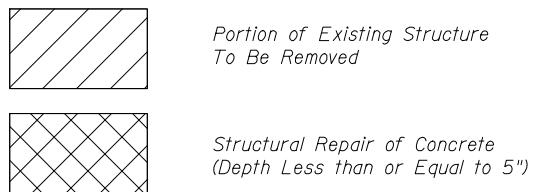

DESIGNED	FGE
CHECKED	JAR
DRAWN	KAS
CHECKED	AJS

STRAND ASSOCIATES, INC.