

PROJECTS WITHOUT RECONSTRUCTION
 ("3R" WITHOUT RECONSTRUCTION, 3P, SMART AND CM)

F.A.I. RTE.	SECTION	COUNTY	TOTAL SHEETS	SHEET NO.
74	*	CHAMPAIGN	93	65
STA.		TO STA.		
FED. ROAD DIST. NO.		ILLINOIS FED. AID PROJECT		
• (10,92-8 HB-1)BR				
CONTRACT NO. 70695				

S.M.A.R.T. IMPROVEMENTS
 (POLICY RESURFACING; BDE 53-4.03; 1 1/2")

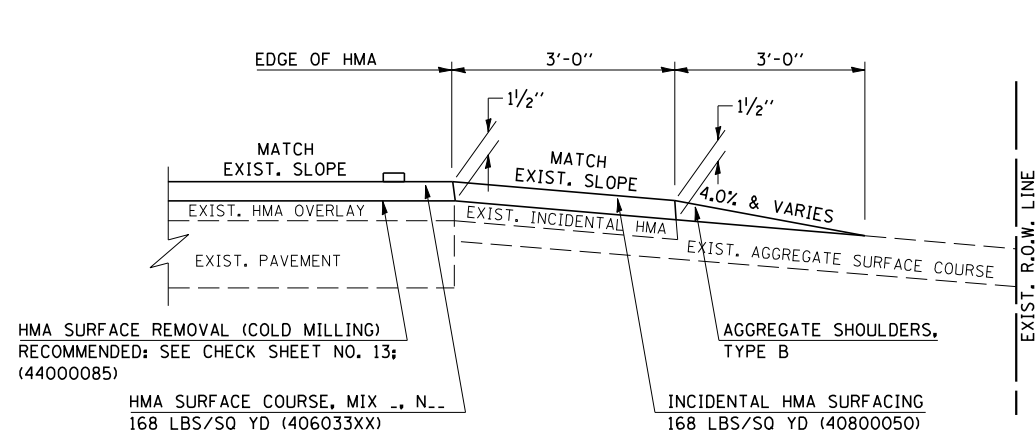

"3P" OR "3R" IMPROVEMENTS
 (POLICY RESURFACING; BDE 53-4.02; 2 1/4" OR 2 1/2" ON BARE CONCRETE)

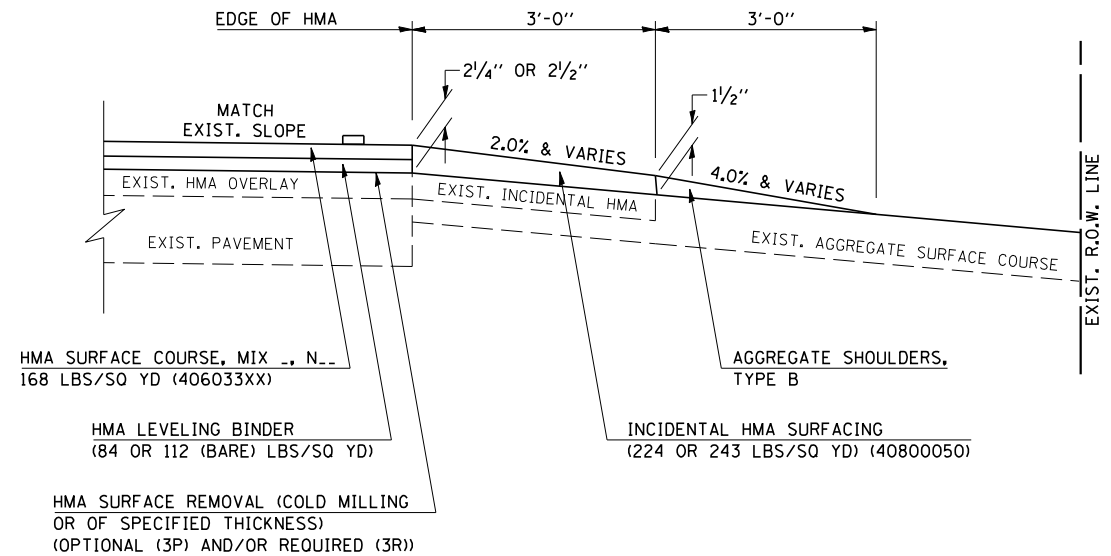

PROJECTS WITH RECONSTRUCTION
 ("3R" IMPROVEMENTS AND SMART/3P "SPOT" LOCATIONS)

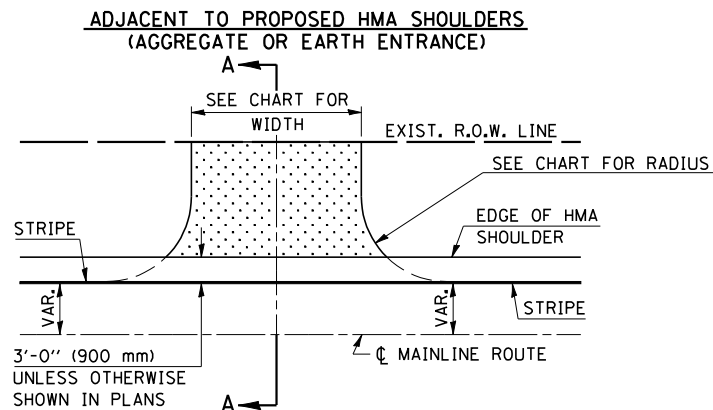

TYPICAL APPLICATION

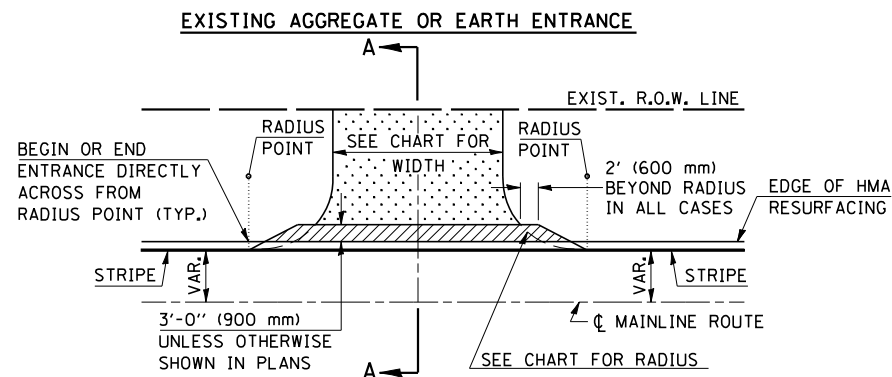

TYPICAL APPLICATION

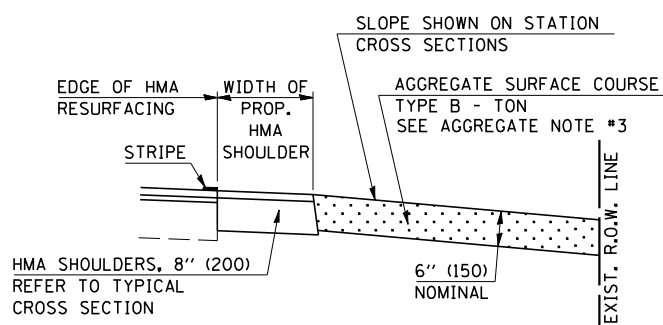

SECTION A-A

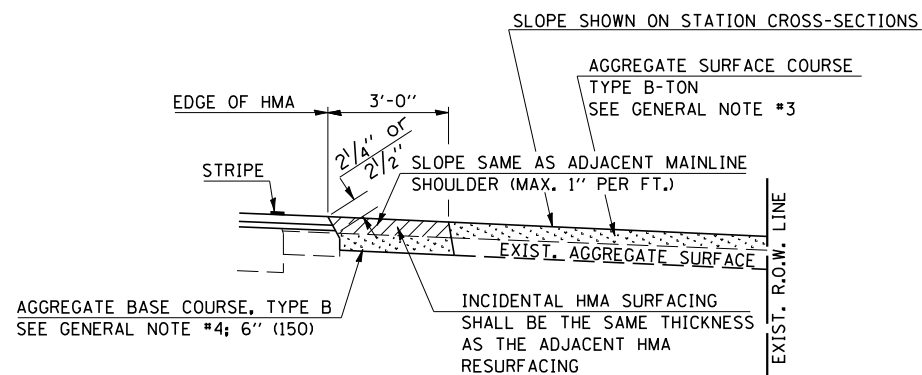

SECTION A-A

Note: All dimensions are in INCHES (millimeters) unless otherwise shown.

DATE	REVISIONS	NAME
12-01-06	RENUMBERED/COMBINED C-1.32 & C-1.26 WITH ADDITIONS OF S.M.A.R.T. & 3P & 3R IMPROV.	T.J.B.

ILLINOIS DEPARTMENT OF TRANSPORTATION

FIELD ENTRANCES (NONCOMMERCIAL RURAL)

DISTRICT 5 DETAIL NO. 40800050A

PLOT DATE : 12/15/2007
 FILE NAME : c:\p03\104691\104691.dwg
 PLOT SCALE : 42,352% / IN.
 USER NAME : collier-b