

FAU ROUTE	SECTION	COUNTY	TOTAL SHEETS	SHEET NO.
8071	*	SANGAMON	425	302
STA.		TO STA.		
FED. ROAD DIST. NO.		ILLINOIS	FED. AID PROJECT	
(84-9) RS-6; (G)Z *				

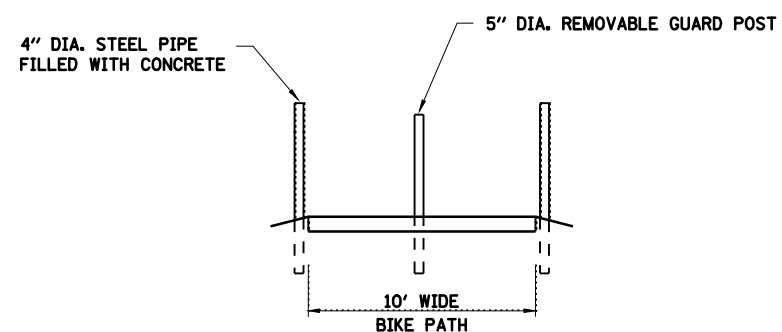

INTERURBAN TRAIL SECTION AT GUARD POST LOCATION

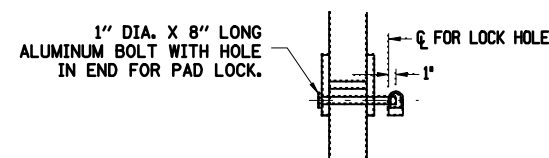
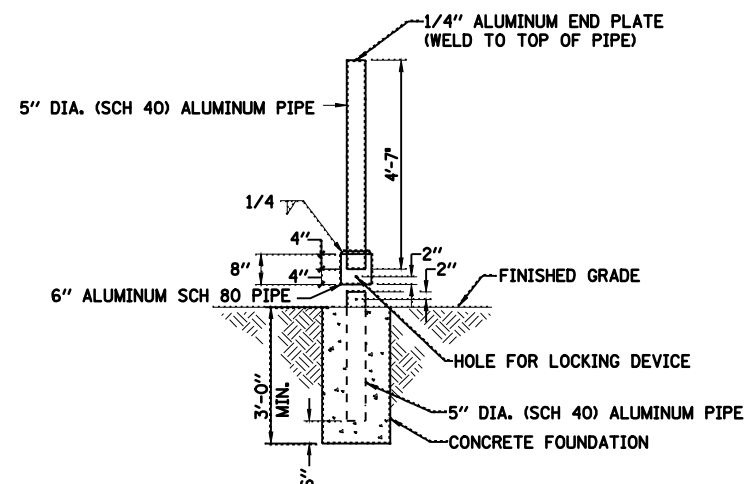

ALL EXCAVATION, BACKFILL, CONCRETE AND PAINT IS INCLUDED IN THE COST OF THE GUARD POST.

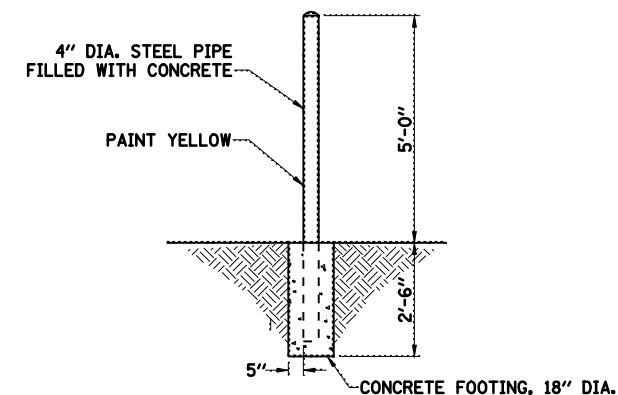

4" DIA. GUARD POST

REVISIONS	
NAME	DATE

ILLINOIS DEPARTMENT OF TRANSPORTATION  
 INTERURBAN TRAIL DETAILS  
 FAI-72, MACARTHUR BLVD  
 SECTION  
 (84-9) RS-6; (G)Z  
 SANGAMON COUNTY, ILLINOIS

SCALE: VERT.      DRAWN BY CLG  
 HORIZ.              CHECKED BY JWM  
 DATE Mar-19-2008 03:24:28PM

LAYOUT	CLG	03/17/07
DRAWN	CLG	03/17/07
REVIEWED	JWM	03/17/07