

F.A. RTE.	SECTION	COUNTY	TOTAL SHEETS	SHEET NO.
*	**	SANGAMON	425	394

STA.	TO STA.
FED. ROAD DIST. NO. - ILLINOIS	FED. AID PROJECT

- FAI 72 (I-72) AND FAU 8071 (MACARTHUR BOULEVARD)
- SECTION (84-9) RS-6; (G)Z

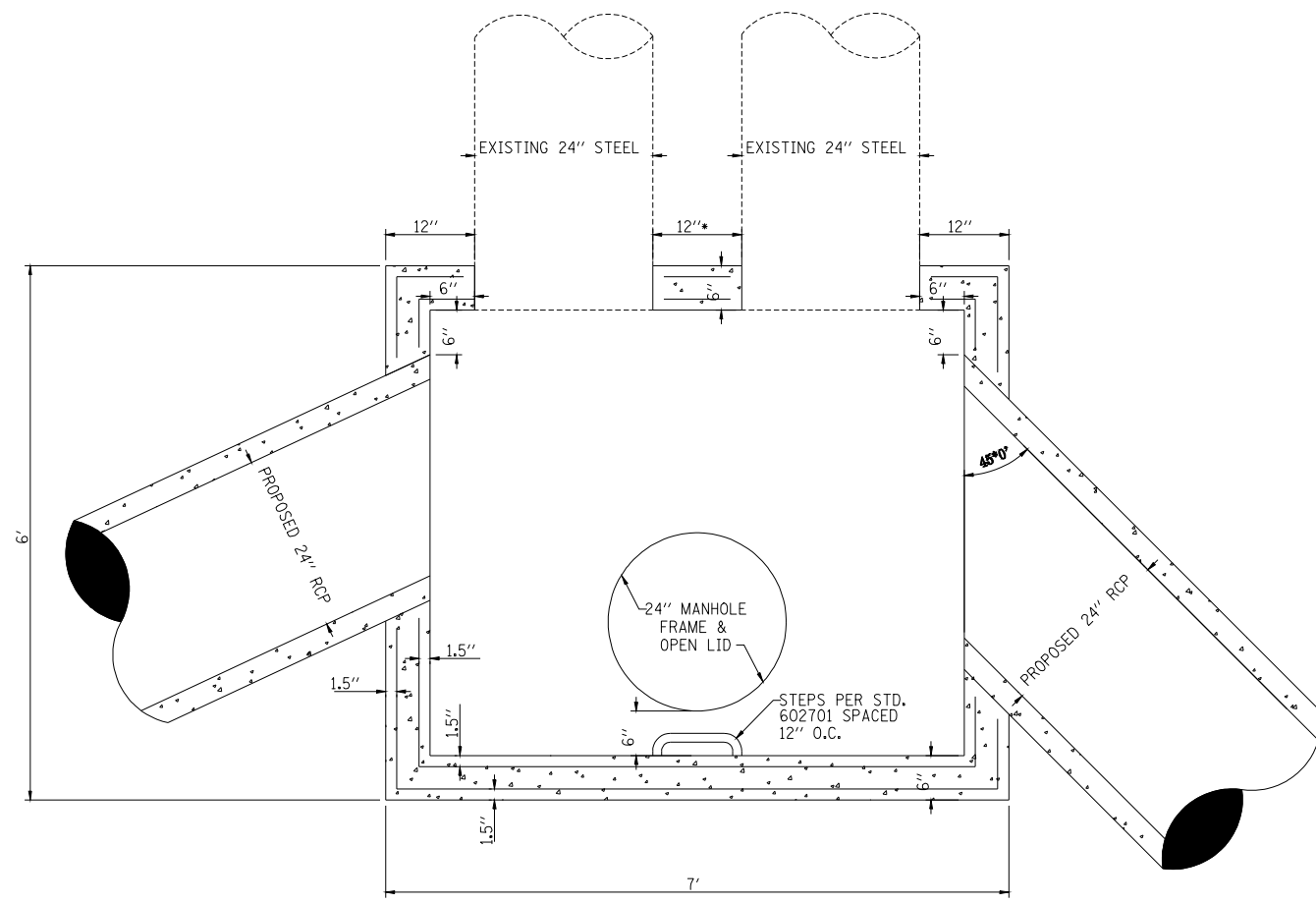

JUNCTION CHAMBER - PLAN VIEW
NOT TO SCALE

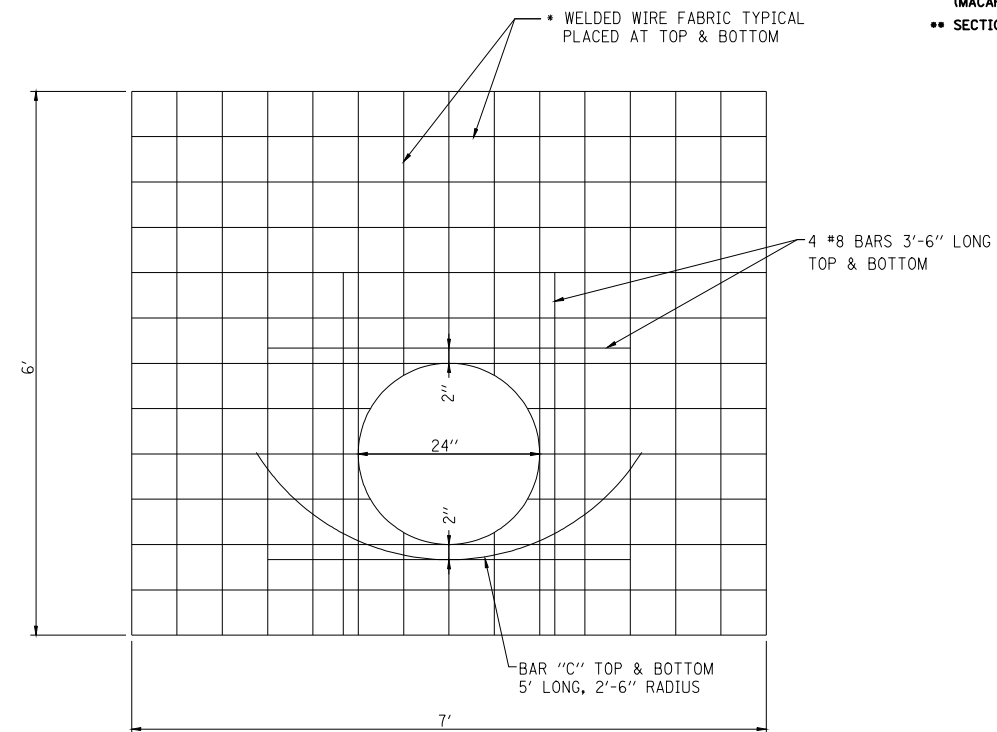

• As WWF EACH DIRECTION 1.71 SQ IN/FT BOTTOM, 0.24 SQ. IN/FT TOP

LID REINFORCEMENT - PLAN VIEW
NOT TO SCALE

BAR	QTY.	SIZE	SHAPE	LENGTH
h	8	#8	—	3'-6"
c	2	#4	—	5' LONG; 2'-6" RADIUS
Concrete			cu. yd.	2.6
Reinforcement bars			lbs.	81.4
Welded-Wire fabric			lbs.	673.3

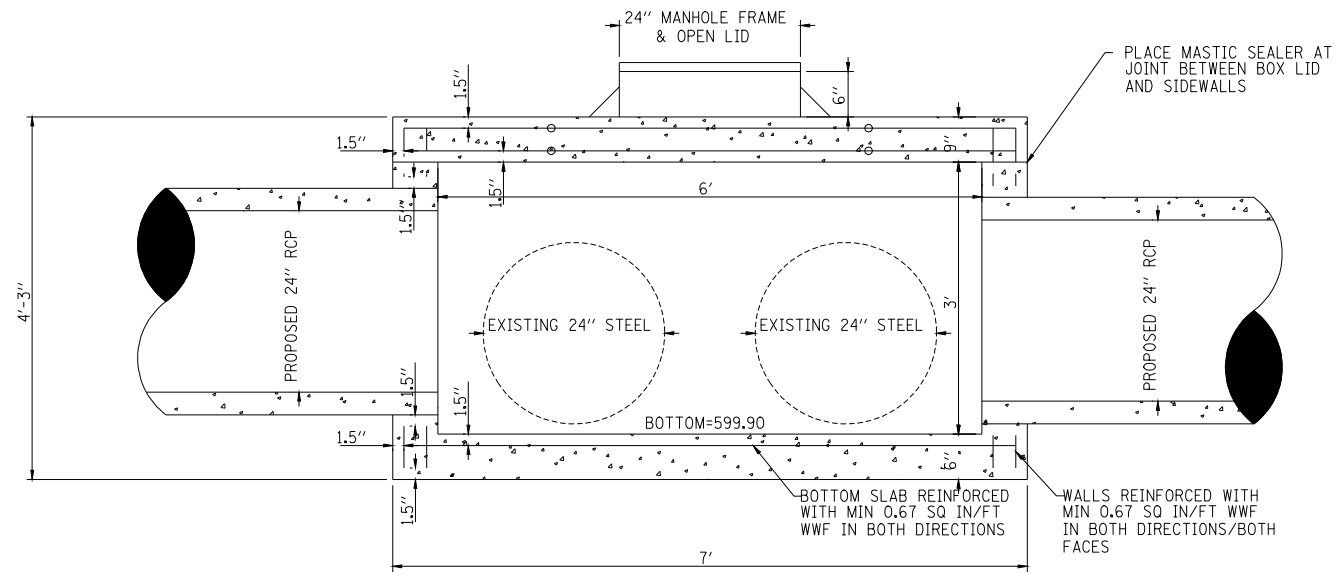

JUNCTION CHAMBER - SECTION
NOT TO SCALE

REVISIONS	
NAME	DATE

SHIVE HATTERY
 Cedar Rapids, IA \ Iowa City, IA \ Des Moines, IA
 Moline, IL \ Bloomington, IL \ Chicago, IL
 SHIVE-HATTERY, INC. 228 EASTLAND DRIVE BLOOMINGTON, ILLINOIS 62706
 PHONE (309) 885-8888 FAX (309) 885-8888
<http://www.shive-hattery.com>
 ILLINOIS PERM. WORKER 34-00054

ILLINOIS DEPARTMENT OF TRANSPORTATION
 LEGACY POINTE SHARED USE PATH
 JUNCTION CHAMBER

SCALE: VERT. NONE
 HORIZ. NONE
 DATE: 9/08

DRAWN BY: JAB
 CHECKED BY: DWS

PLOT DATE = 08-20-2008 11:44:54AM
 FILE NAME = C:\Project\6865007\shive-hattery\c0-07.dgn
 PLOT SCALE = 2.18 / IN.
 USER NAME = jhughes