

PROPOSED IL 154  
STA. 900+73 TO STA. 910+29

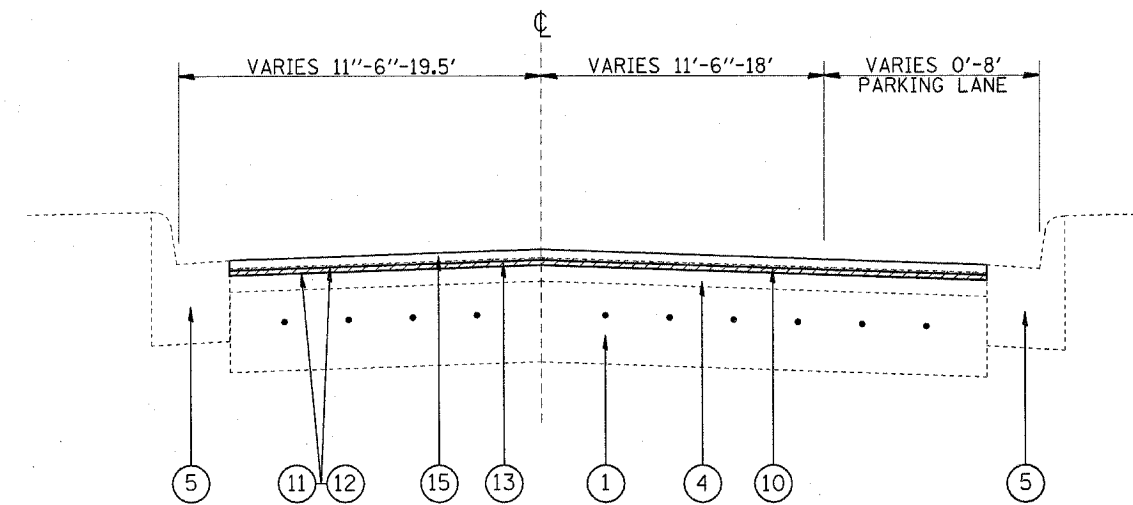

PROPOSED IL 154  
STA. 918+36 TO STA. 935+47  
(WALNUT ST. TO ST. LOUIS ST.)

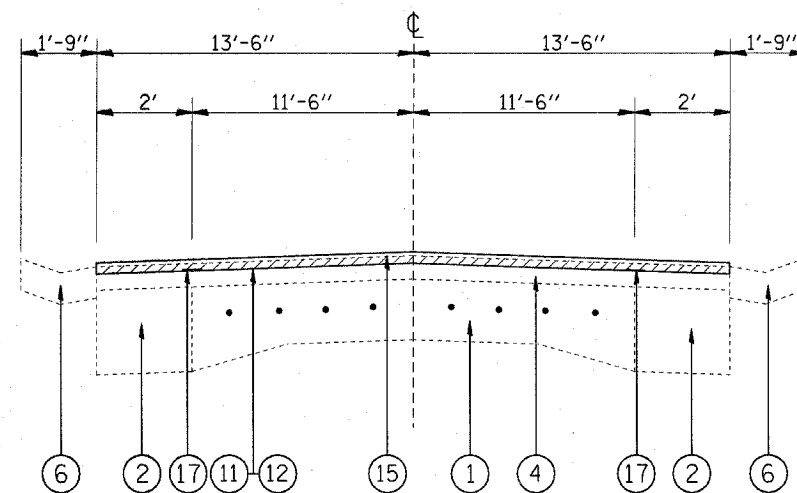

PROPOSED IL 154  
STA. 910+29 TO STA. 918+36

LEGEND

- ① EXISTING P.C.C. PAVEMENT (9'-6"-9")
- ② EXISTING HOT-MIX ASPHALT BASE COURSE WIDENING, 9"
- ③ EXISTING CONCRETE WIDENING, 8"
- ④ EXISTING HOT-MIX ASPHALT RESURFACING, 3"
- ⑤ EXISTING CONCRETE CURB AND GUTTER
- ⑥ EXISTING CONCRETE GUTTER
- ⑦ EXISTING HOT-MIX ASPHALT PARKING LANE
- ⑧ EXISTING P.C.C. PAVEMENT, 8"
- ⑨ EXISTING STABILIZED SHOULDER, 8", TO BE REMOVED
- ⑩ PROPOSED HOT-MIX ASPHALT SURFACE REMOVAL, 1"
- ⑪ PROPOSED AGGREGATE (PRIME COAT)
- ⑫ PROPOSED BITUMINOUS MATERIALS (PRIME COAT)
- ⑬ PROPOSED LEVELING BINDER (MACHINE METHOD), N90, 3/4"
- ⑭ PROPOSED LEVELING BINDER (MACHINE METHOD), N90, 1"
- ⑮ PROPOSED HOT-MIX ASPHALT SURFACE COURSE, 1 1/2"
- ⑯ PROPOSED HOT-MIX ASPHALT SHOULDERS, 10 1/2"
- ⑰ PROPOSED STRIP REFLECTIVE CRACK CONTROL
- ⑱ PROPOSED AGGREGATE WEDGE SHOULDER, TYPE B

FILE NAME =	USER NAME = dintelmanjn	DESIGNED -	REVISED -
at\projects\ed01500\plan\pin01508a.dgn		DRAWN -	REVISED -
	PLOT SCALE = 50.0000' / IN.	CHECKED -	REVISED -
	PLOT DATE = 3/21/2008	DATE -	REVISED -

STATE OF ILLINOIS  
DEPARTMENT OF TRANSPORTATION

TYPICAL SECTIONS

SCALE: \_\_\_\_\_ SHEET NO. \_\_\_\_ OF \_\_\_\_ SHEETS STA. \_\_\_\_\_ TO STA. \_\_\_\_\_

F.A.P. RTE.	SECTION	COUNTY	TOTAL SHEETS	SHEET NO.
329	(125,126)RS-2	RANDOLPH	34	10
FED. ROAD DIST. NO. - ILLINOIS FED. AID PROJECT			CONTRACT NO. 76B38	