

ROUTE NO.	SECTION	COUNTY	SHEETS	SHEET NO.
F.A.I. 57	00-00374 -03-15	Champaign	21	7
FED. ROAD DIST. NO.	ILLINOIS	FED. AID PROJECT		

SHEET NO. 7

21 SHEETS

Contract # 91382

**MASONRY NOTES:**

- MASONRY WORK ON THIS PROJECT SHALL CONFORM TO ALL REQUIREMENTS OF ACI 530.1-99, SPECIFICATION FOR MASONRY STRUCTURES, PUBLISHED BY THE AMERICAN CONCRETE INSTITUTE (ACI), DETROIT, MICHIGAN, EXCEPT AS MODIFIED BY THE REQUIREMENTS OF THESE CONTRACT DOCUMENTS.
- CONTRACTOR SHALL SUBMIT SHOP DRAWINGS SHOWING ALL WALL REINFORCING.
- CONCRETE MASONRY UNITS SHALL BE IN ACCORDANCE WITH ASTM C90, GRADE N, TYPE I.
- MORTAR SHALL CONFORM TO ASTM C270, TYPE S MORTAR.
- COMPRESSIVE STRENGTH OF CONCRETE MASONRY (f'm) SHALL BE 1500 PSI MINIMUM.
- BAR REINFORCEMENT SHALL CONFORM TO ASTM A615 GRADE 60.
- LENGTH OF BAR SPLICES SHALL BE EQUAL TO 48 BAR DIAMETERS.
- JOINT REINFORCEMENT SHALL BE MADE OF COLD DRAWN WIRE AND SHALL CONFORM TO ASTM A82. JOINT REINFORCEMENT SHALL BE:
  - 3-9 GA. WIRE, LADDER TYPE - FOR WALLS WITH BRICK VENEER
- JOINT REINFORCEMENT, TIES AND ANCHORS SHALL BE GALVANIZED IN ACCORDANCE WITH ACI 530.1.
- JOINT REINFORCEMENT SHALL BE PLACED IN ALL MASONRY WALLS AND SPACED 16" O.C., UNLESS OTHERWISE NOTED.
- ALL CELLS WITH REINFORCEMENT, BOND BEAMS, MASONRY LINTELS AND SILLS SHALL BE FULLY GROUTED. GROUT SHALL CONFORM TO ASTM C476 AND SHALL HAVE 28-DAY COMPRESSIVE STRENGTH OF 2000 PSI MINIMUM.
- VERTICAL REINFORCEMENT SHALL TERMINATE WITH A 90 DEGREE HOOK AT THE TOP OF ALL WALLS.
- LAY CONCRETE MASONRY UNITS WITH FULL MORTAR COVERAGE ON HORIZONTAL AND VERTICAL FACE SHELLS AND WEBS.
- MASONRY APPURTENANCES INCLUDING MASONRY DOWEL RODS, DOVE TAIL ANCHORS, WIRE REINFORCEMENT, BOND BEAMS AND MASONRY REINFORCEMENT ARE INCLUDED IN THE UNIT PRICE FOR MASONRY COLUMN OF THE SIZE SPECIFIED AND NO ADDITIONAL COMPENSATION WILL BE ALLOWED.

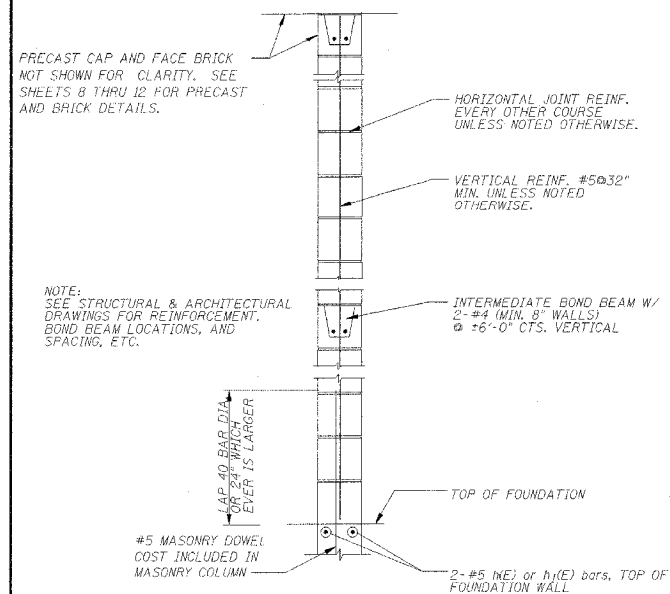

TYPICAL MASONRY WALL

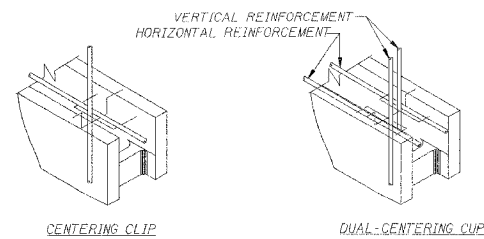

CENTERING AND CAGING DEVICES

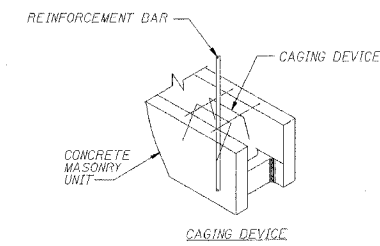

NOTE: CENTERING AND CAGING DEVICES SHALL BE FORMED FROM #9 HARD STEEL WIRE, SPOT WELDED AND GALVANIZED.

CENTERING AND CAGING DEVICES

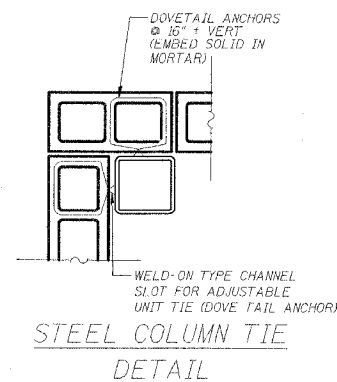

STEEL COLUMN TIE DETAIL

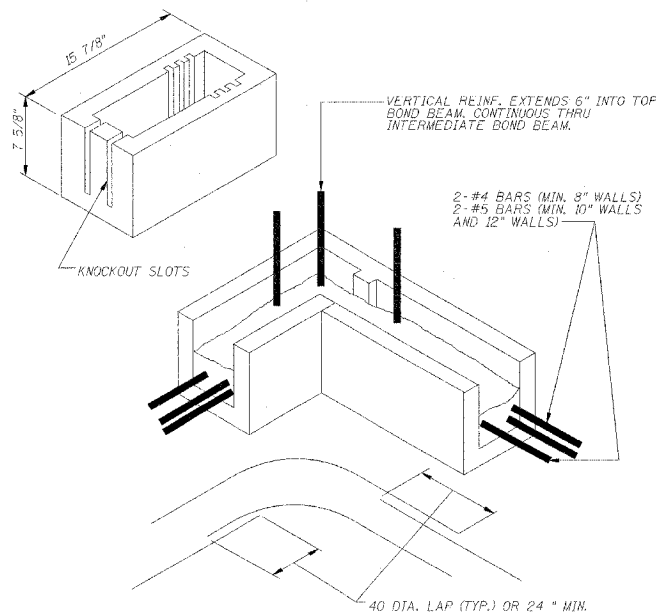

BOND BEAM UNIT AT CORNER

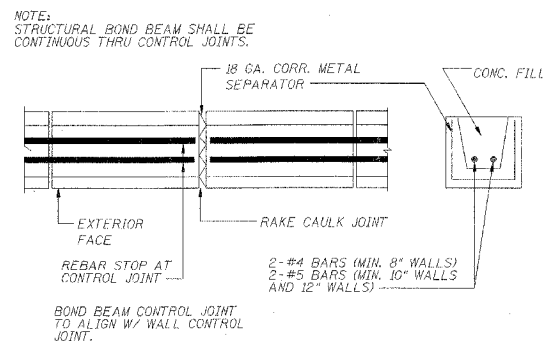

PLAN SECTION  
NON-STRUCTURAL BOND  
BEAM CONTROL JOINT

DESIGNED	SLD
CHECKED	SMM
DRAWN	SLD
CHECKED	SMM

**MASONRY DETAILS**  
**CURTIS ROAD BRIDGE ENHANCEMENTS**  
**CHAMPAIGN COUNTY**  
**STATION 297+20.45**



DESIGN FIRM REGISTRATION  
No. 184-000450  
1817 SOUTH NEIL STREET  
SUITE 100  
CHAMPAIGN, IL 61820  
PHONE : 217.373.8900  
FAX : 217.373.8923