

NORTH EDGE OF APPROACH

Location	Station	Offset	Theoretical Grade Elevations
W. End W. Appr. Slab	19+93.60	-40.50	600.57
A1	20+03.60	-40.50	600.78
A2	20+13.60	-40.50	601.00
E. End W. Appr. Slab	20+23.60	-40.50	601.23

NORTH GUTTER LINE

Location	Station	Offset	Theoretical Grade Elevations
W. End W. Appr. Slab	19+93.60	-30.50	600.46
A1	20+03.60	-30.50	600.67
A2	20+13.60	-30.50	600.89
E. End W. Appr. Slab	20+23.60	-30.50	601.12

STAGE CONST. LINE

Location	Station	Offset	Theoretical Grade Elevations
W. End W. Appr. Slab	19+93.60	-25.63	600.53
A1	20+03.60	-25.63	600.74
A2	20+13.60	-25.63	600.96
E. End W. Appr. Slab	20+23.60	-25.63	601.19

CL 63RD STREET & P.G.

Location	Station	Offset	Theoretical Grade Elevations
W. End W. Appr. Slab	19+93.60	0.00	600.91
A1	20+03.60	0.00	601.12
A2	20+13.60	0.00	601.35
E. End W. Appr. Slab	20+23.60	0.00	601.58

SOUTH GUTTER LINE

Location	Station	Offset	Theoretical Grade Elevations
W. End W. Appr. Slab	19+93.60	30.50	600.46
A1	20+03.60	30.50	600.67
A2	20+13.60	30.50	600.89
E. End W. Appr. Slab	20+23.60	30.50	601.12

SOUTH EDGE OF APPROACH

Location	Station	Offset	Theoretical Grade Elevations
W. End W. Appr. Slab	19+93.60	40.50	600.71
A1	20+03.60	40.50	600.92
A2	20+13.60	40.50	601.14
E. End W. Appr. Slab	20+23.60	40.50	601.37

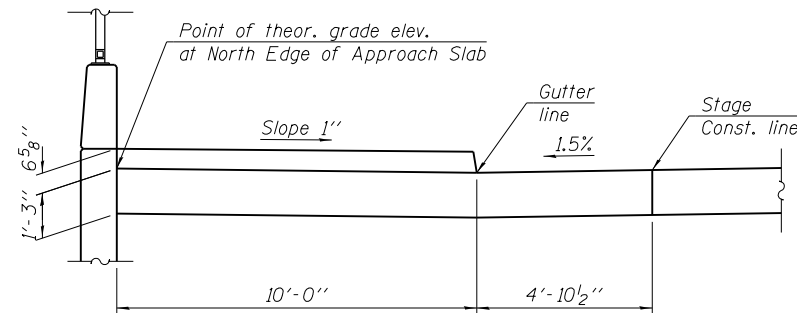
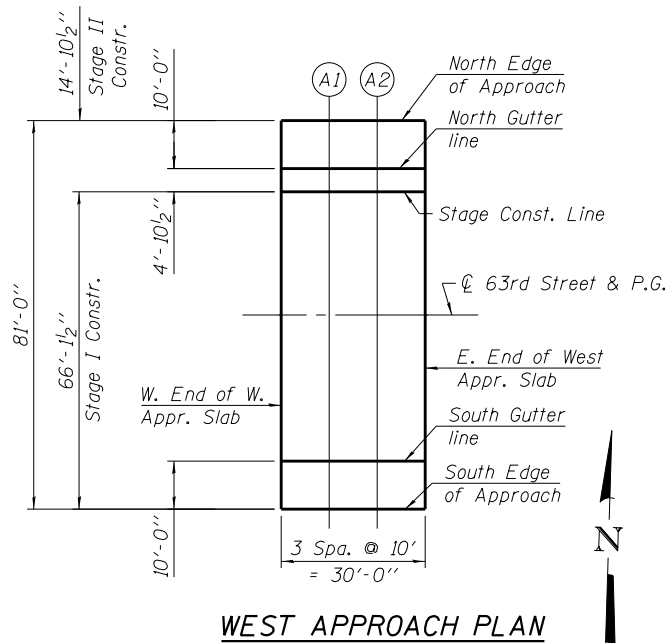

SECTION THRU NORTH SIDEWALK
(Looking East)

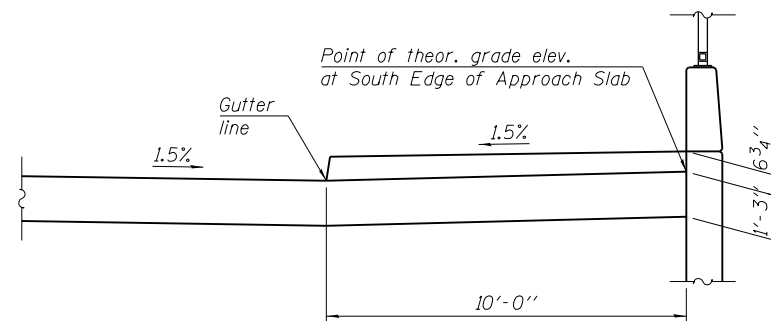

SECTION THRU SOUTH SIDEWALK
(Looking East)

H:\projects\2013\0223\CAD\Structure\dwg\06-1149-Final\00\160105-s13-towa.dgn
 3/27/2014 4:55:18 PM

USER NAME =	DESIGNED - J.Z.	REVISED -
	CHECKED - J.A.Z.	REVISED -
PLOT SCALE =	DRAWN - E.E.J.	REVISED -
PLOT DATE =	DATE - 3/31/2014	REVISED -

F.A.I. RTE.	SECTION	COUNTY	TOTAL SHEETS	SHEET NO.
94	1920-B	COOK	142	77
CONTRACT NO. 60J15				
ILLINOIS FED. AID PROJECT				