

Hatched area to be poured after superstructure forms have been removed. Quantity of concrete included with Concrete Superstructure.

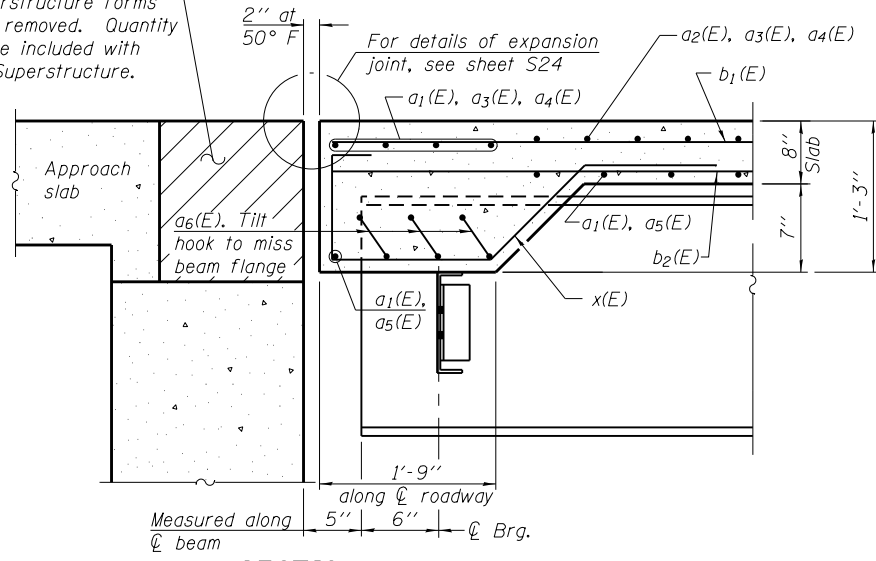

SECTION A-A

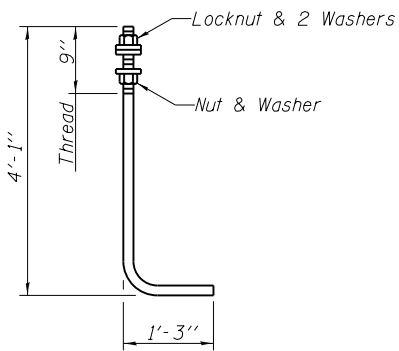

ANCHOR ROD

Diameter as specified for light poles. (ASTM F 1554 Grade 105)

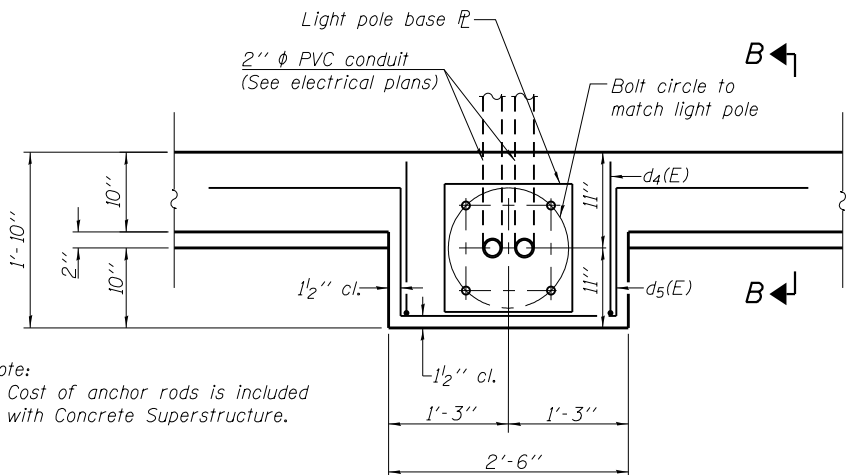

PLAN-LIGHT POLE BASE

Note: Cost of anchor rods is included with Concrete Superstructure.

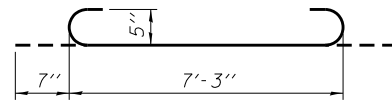

BAR a6(E)

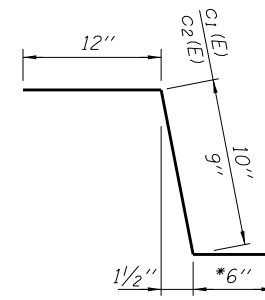

BARS c1(E) & c2(E)

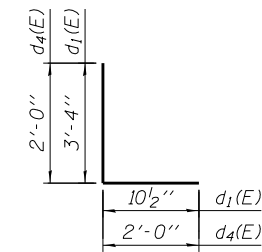

BARS d1(E) & d4(E)

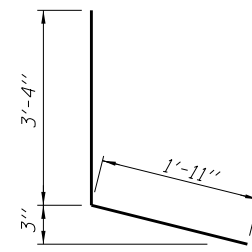

BAR d2(E)

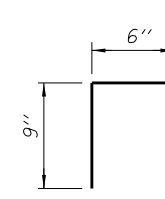

BAR d3(E)

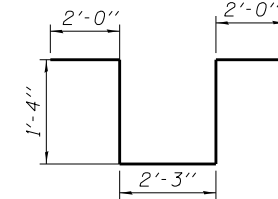

BAR d5(E)

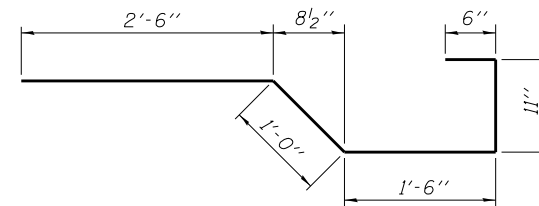

BAR x(E)

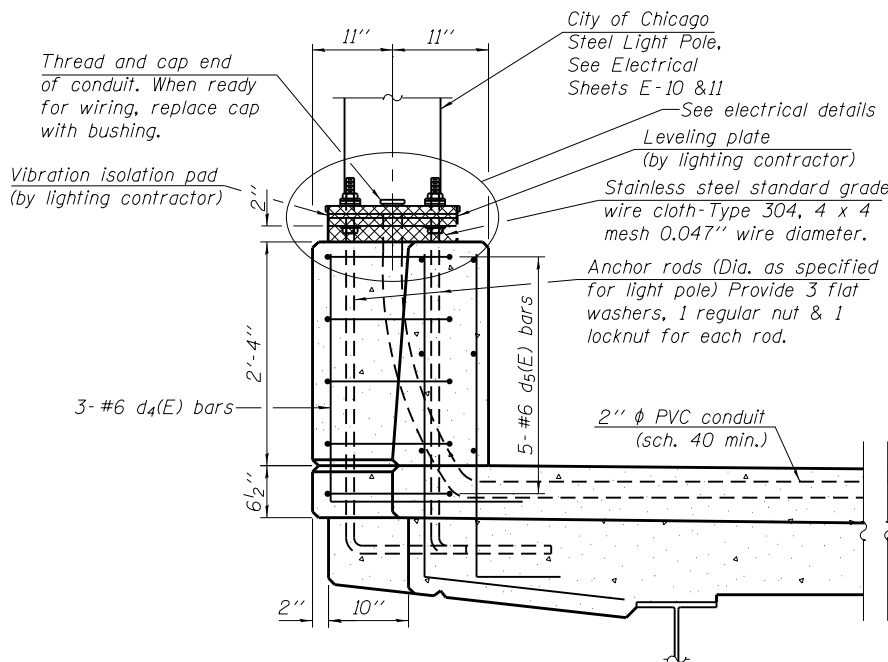

SECTION B-B

(Typical, 4 Locations)

*In lieu of bottom leg, the deck may be drilled and the c1(E) and c2(E) bars may be set according to Article 509.06 of the Standard Specifications. Drilled holes shall be roughened or scored per manufacturer's recommendations. Maximum depth of hole shall not exceed 6". Contractor shall take all necessary precautions to prevent drilled hole interference with deck reinforcement bars. Locate longitudinal bars to miss drilled locations. Locate drilled holes to miss transverse bars in deck.

**SUPERSTRUCTURE
BILL OF MATERIAL**

Bar	No.	Size	Length	Shape	
a1(E)	824	#5	34'-10"	—	
a2(E)	658	#5	31'-3"	—	
a3(E)	658	#5	38'-8"	—	
a4(E)	666	#5	15'-4"	—	
a5(E)	404	#5	15'-0"	—	
a6(E)	54	#5	8'-5"	—	
a7(E)	32	#5	1'-6"	—	
b1(E)	1199	#5	30'-6"	—	
b2(E)	792	#5	28'-4"	—	
b3(E)	166	#6	36'-0"	—	
b4(E)	166	#6	35'-6"	—	
c1(E)	301	#5	2'-4"	—	
c2(E)	301	#5	2'-3"	—	
c3(E)	602	#5	10'-6"	—	
d1(E)	584	#6	4'-3"	—	
d2(E)	584	#4	5'-3"	—	
d3(E)	140	#4	2'-0"	—	
d4(E)	12	#6	4'-0"	—	
d5(E)	20	#6	8'-11"	—	
e1(E)	48	#4	16'-4"	—	
e2(E)	64	#4	9'-2"	—	
e3(E)	96	#4	13'-11"	—	
e4(E)	64	#4	7'-5"	—	
e5(E)	8	#4	12'-5"	—	
e6(E)	8	#4	13'-10"	—	
e7(E)	48	#4	15'-11"	—	
e8(E)	24	#4	15'-8"	—	
x(E)	166	#5	6'-5"	—	
Reinforcement Bars, Epoxy Coated				Pound	193,270
Concrete Superstructure				Cu. Yds.	865.3

H:\projects\2011\0223\CAD\Structural\06-1149_Final\00\06\015-s19-deck-d12.dgn 3/27/2014 4:55:26 PM