

**EXISTING TYPICAL SECTION**

STA. 2+41 TO 17+65  
 STA. 20+61 TO 44+75  
 STA. 49+84 TO 72+00  
 STA. 81+00 TO 88+00  
 STA. 91+90 TO 107+19  
 STA. 109+19 TO 119+91

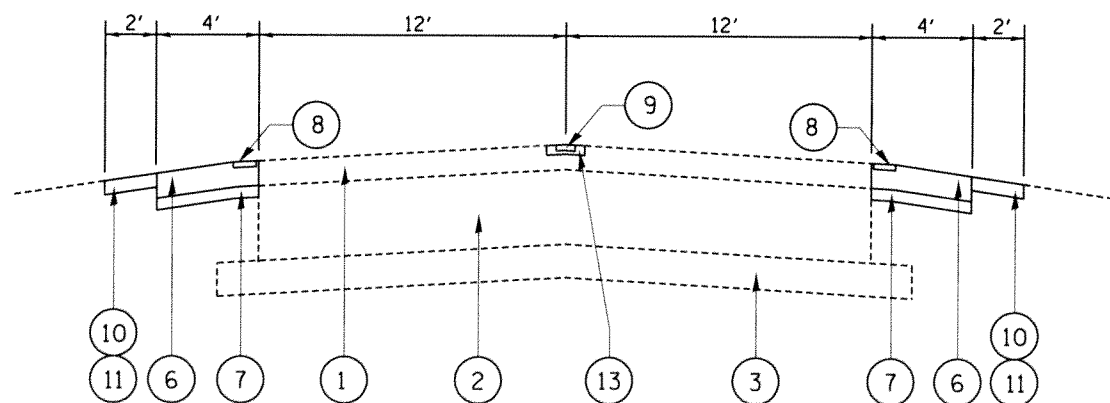

**PROPOSED TYPICAL SECTION**

STA. 2+41 TO 17+65  
 STA. 20+61 TO 44+75  
 STA. 49+84 TO 72+00  
 STA. 81+00 TO 88+00  
 STA. 91+90 TO 107+19  
 STA. 109+19 TO 119+91

**LEGEND:**

- ① EXIST. HOT-MIX ASPHALT SURFACE, ±6"
- ② EXIST. P.C.C. PAVEMENT, ±9"
- ③ EXIST. STABILIZED SUB-BASE
- ④ EXIST. AGGREGATE SHOULDERS
- ⑤ EXIST. GUARDRAIL
- ⑥ PROP. HOT-MIX ASPHALT SHOULDER, 8"
- ⑦ PROP. SUB-BASE GRANULAR MATERIAL, TYPE B, 4"
- ⑧ PROP. SHOULDER RUMBLE STRIPS (8" WIDE)
- ⑨ PROP. CENTERLINE RUMBLE STRIPS (16" WIDE)
- ⑩ PROP. GRADING AND SHAPING SHOULDERS (WHERE NECESSARY)
- ⑪ PROP. AGGREGATE SHOULDERS, TYPE B (WHERE NECESSARY)
- ⑫ PROP. PARTIAL DEPTH REMOVAL, 3"
- ⑬ PROP. PARTIAL DEPTH PATCHING
- ⑭ PROP. STEEL PLATE BEAM GUARDRAIL

▨ DENOTES ITEMS TO BE REMOVED

**MIXTURE REQUIREMENTS FOR SHOULDER RECONSTRUCTION**

MIXTURE TYPE	AIR VOIDS @ Ndes	OMP
HOT-MIX ASPHALT BINDER COURSE, 6" (HMA BINDER, IL-19MM)	4% @ 70 GYR.	OCP
HOT-MIX ASPHALT SURFACE COURSE, MIX "D", N70 2" (IL-9.5MM)	4% @ 70 GYR.	OCP
OMP DESIGNATION: QUALITY CONTROL FOR PERFORMANCE (OCP)		

**NOTES:**

THE UNIT WEIGHT USED TO CALCULATE ALL HOT-MIX ASPHALT QUANTITIES IS 112 LBS./SQ. YD./ IN.

THE "AC TYPE" FOR POLYMERIZED HMA MIXES SHALL BE "SBS/SBR PG 76 -22" AND FOR NON-POLYMERIZED HMA THE "AC TYPE" SHALL BE "PG 64 -22" UNLESS MODIFIED BY DISTRICT ONE SPECIAL PROVISIONS. FOR USE OF RECYCLED MATERIALS SEE DISTRICT ONE SPECIAL PROVISIONS.

QUALITY MANAGEMENT PROGRAM (OMP) IDENTIFIES THE PARTICULAR QUALITY CONTROL SPECIFICATION THAT APPLIES TO THE HMA MIXTURE