

SOUTH EDGE OF SHOULDER

Location	Station	Offset	Theoretical Grade Elevations
E. End of E. Appr. Pav't.	56+71.24	-15.00	528.43
A1	56+81.24	-15.00	528.21
A2	56+91.24	-15.00	527.99
W. End of E. Appr. Pav't.	57+01.24	-15.00	527.77
E. End of W. Appr. Pav't.	58+04.39	-15.00	525.50
A3	58+14.39	-15.00	525.28
A4	58+24.39	-15.00	525.06
W. End of W. Appr. Pav't.	58+34.39	-15.00	524.84

SOUTH EDGE OF PAVEMENT

Location	Station	Offset	Theoretical Grade Elevations
E. End of E. Appr. Pav't.	56+72.85	-11.00	528.48
A1	56+82.85	-11.00	528.26
A2	56+92.85	-11.00	528.04
W. End of E. Appr. Pav't.	57+02.85	-11.00	527.82
E. End of W. Appr. Pav't.	58+06.01	-11.00	525.55
A3	58+16.01	-11.00	525.33
A4	58+26.01	-11.00	525.11
W. End of W. Appr. Pav't.	58+36.01	-11.00	524.89

☐ OF ROADWAY & P.G.

Location	Station	Offset	Theoretical Grade Elevations
E. End of E. Appr. Pav't.	56+77.30	0.00	528.55
A1	56+87.30	0.00	528.33
A2	56+97.30	0.00	528.11
W. End of E. Appr. Pav't.	57+07.30	0.00	527.89
E. End of W. Appr. Pav't.	58+10.45	0.00	525.62
A3	58+20.45	0.00	525.40
A4	58+30.45	0.00	525.18
W. End of W. Appr. Pav't.	58+40.45	0.00	524.96

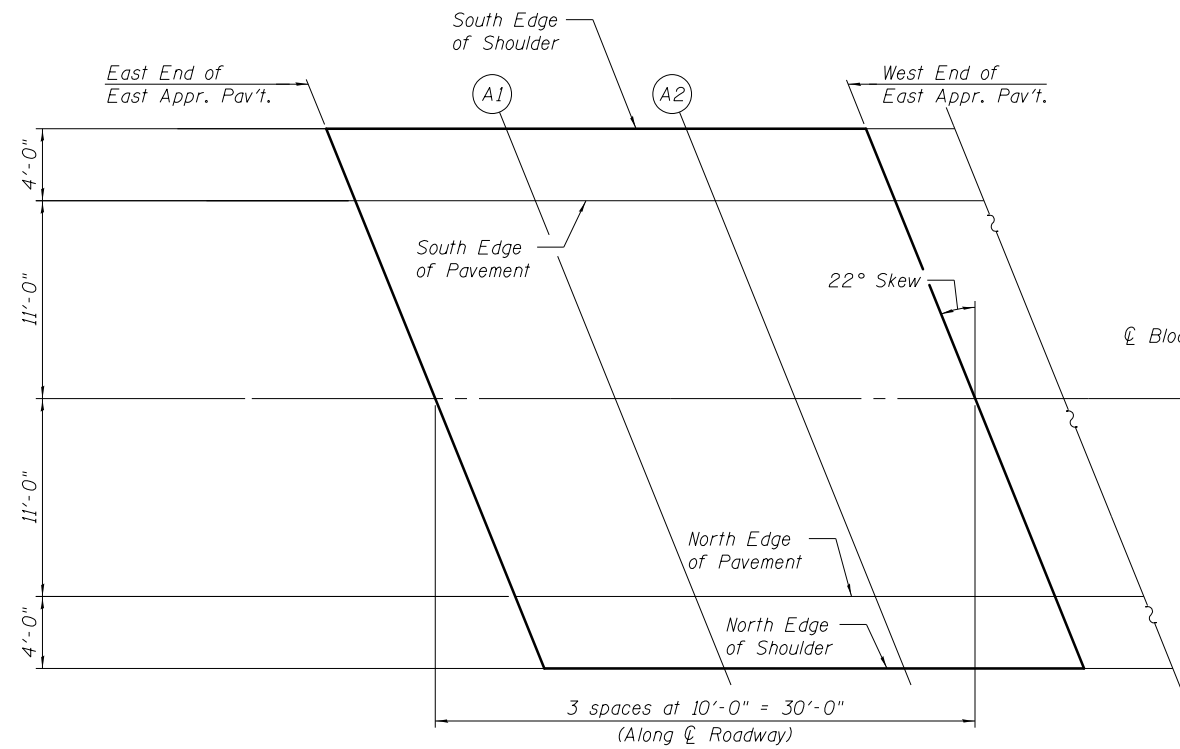

PLAN

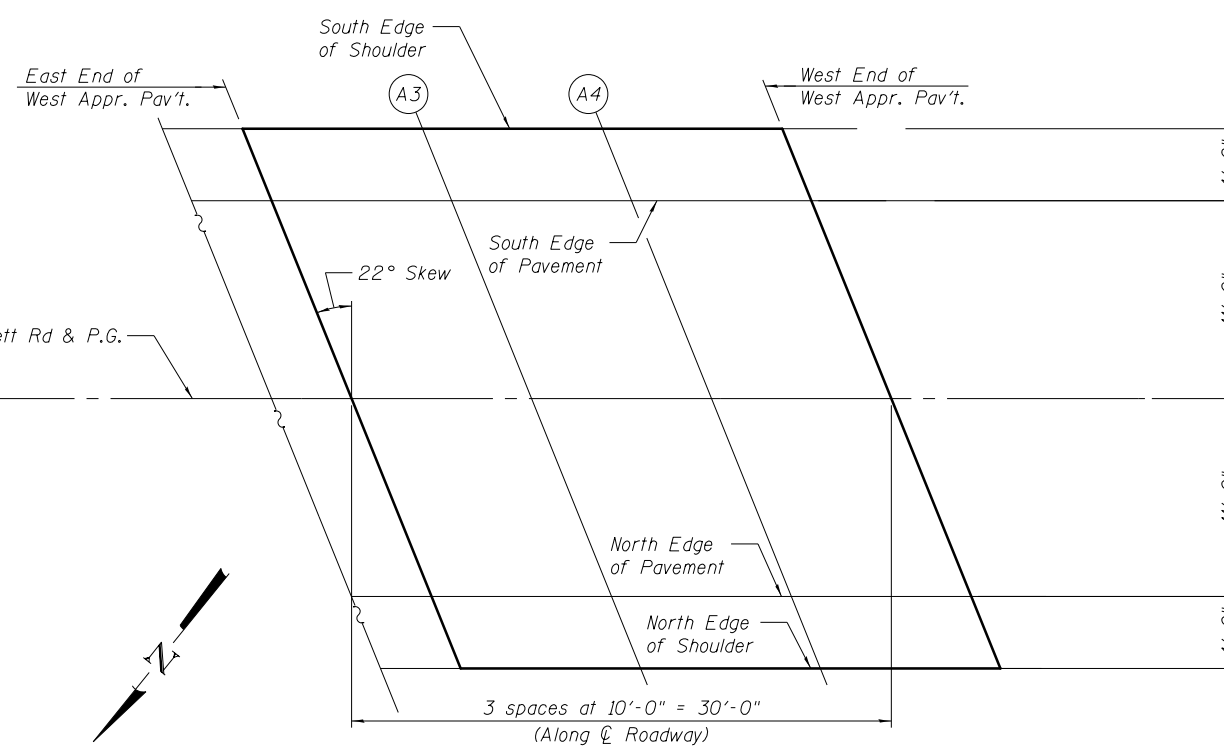

PLAN

NORTH EDGE OF PAVEMENT

Location	Station	Offset	Theoretical Grade Elevations
E. End of E. Appr. Pav't.	56+81.74	11.00	528.29
A1	56+91.74	11.00	528.06
A2	57+01.74	11.00	527.84
W. End of E. Appr. Pav't.	57+11.74	11.00	527.62
E. End of W. Appr. Pav't.	58+14.90	11.00	525.35
A3	58+24.90	11.00	525.13
A4	58+34.90	11.00	524.91
W. End of W. Appr. Pav't.	58+44.90	11.00	524.69

NORTH EDGE OF SHOULDER

Location	Station	Offset	Theoretical Grade Elevations
E. End of E. Appr. Pav't.	56+83.36	15.00	528.17
A1	56+93.36	15.00	527.95
A2	57+03.36	15.00	527.73
W. End of E. Appr. Pav't.	57+13.36	15.00	527.51
E. End of W. Appr. Pav't.	58+16.51	15.00	525.23
A3	58+26.51	15.00	525.01
A4	58+36.51	15.00	524.79
W. End of W. Appr. Pav't.	58+46.51	15.00	524.57

FILENAME: F:\3-1319\Blodgett\Drawings\CADD\Sheets\099-0181-105-Appr-Elevs.dgn



USER NAME = tborges	DESIGNED - BCM	REVISED
	CHECKED - BCM	REVISED
PLOT SCALE = N/A	DRAWN - KO	REVISED
PLOT DATE = 3/31/2014	CHECKED - 6/19/2012	REVISED

**STATE OF ILLINOIS  
DEPARTMENT OF TRANSPORTATION**

**TOP OF APPROACH SLAB ELEVATIONS  
STRUCTURE NO. 099-0181**

SHEET NO. S5 OF S20 SHEETS

F.A.I. RTE.	SECTION	COUNTY	TOTAL SHEETS	SHEET NO.
55	99-2HB-3I-3	WILL	87	43
CONTRACT NO. 60X60				
ILLINOIS FED. AID PROJECT				