

EXISTING TYPICAL SECTION

- ROAD 6 STA 608+89 TO STA 611+17
- ROAD 6 STA 616+03 TO STA 616+90
- ROAD 6A STA 625+12 TO STA 626+40

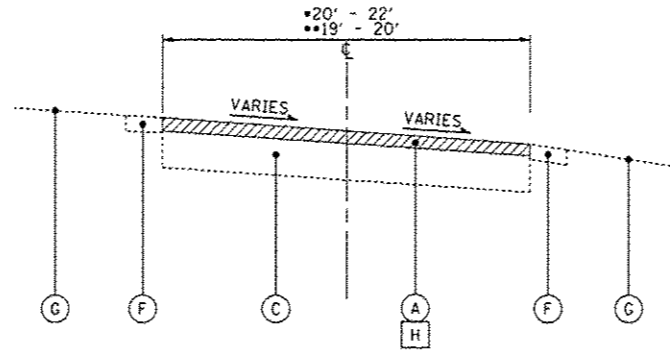

EXISTING TYPICAL SECTION

- ROAD 6
- ROAD 6 STA 611+17 TO STA 614+48
- ROAD 6 STA 616+90 TO STA 620+55

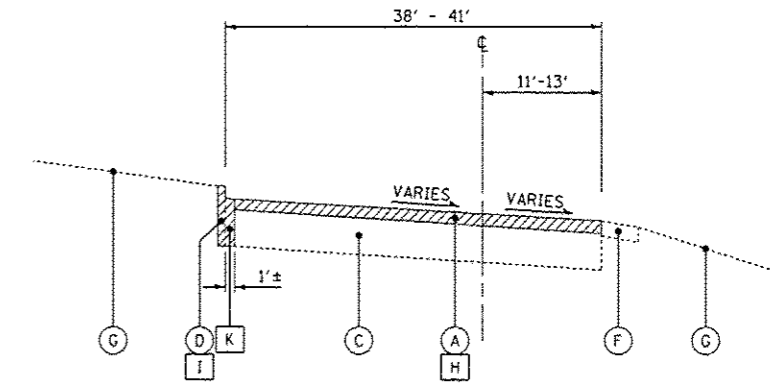

EXISTING TYPICAL SECTION

- ROAD 6
- STA 614+48 TO STA 616+03

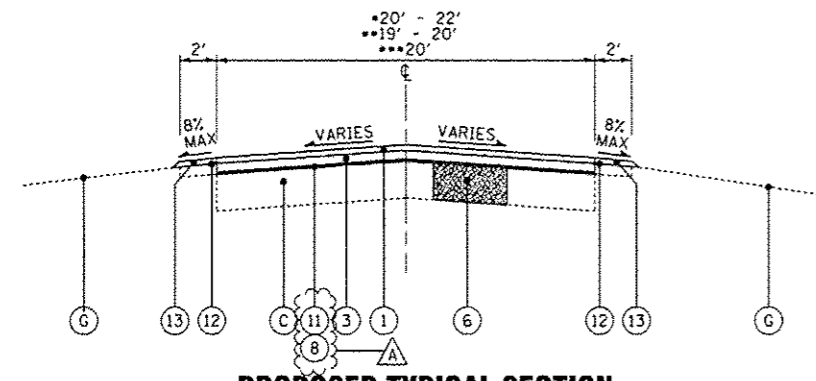

PROPOSED TYPICAL SECTION

- ROAD 6 STA 608+89 TO STA 611+17
- ROAD 6 STA 616+03 TO STA 616+90
- ROAD 6A STA 625+12 TO STA 626+40

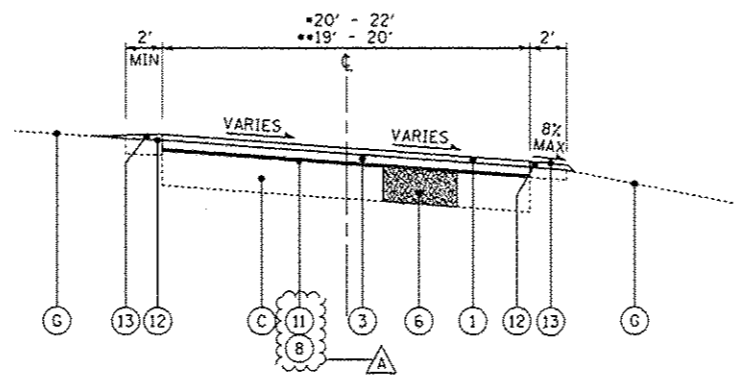

PROPOSED TYPICAL SECTION

- ROAD 6
- ROAD 6 STA 611+17 TO STA 614+48
- ROAD 6 STA 616+90 TO STA 620+55

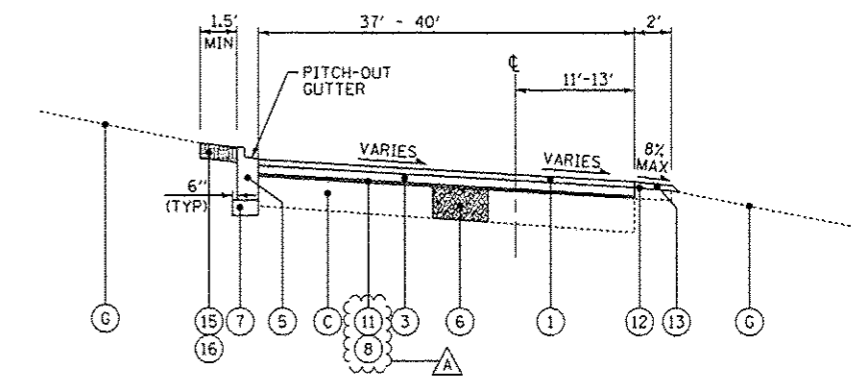

PROPOSED TYPICAL SECTION

- ROAD 6
- STA 614+48 TO STA 616+03

EXISTING LEGEND

- (A) EXISTING HMA SURFACE - 1 1/2" - 2 1/2"
- (AA) EXISTING HMA SURFACE - 4"
- (B) EXISTING PCC PAVEMENT - 6"
- (C) EXISTING AGGREGATE BASE - 1" - 8"
- (D) EXISTING CURB
- (E) EXISTING CURB AND GUTTER
- (F) EXISTING AGGREGATE SHOULDER - 3"± (WHERE IT EXISTS)
- (G) EXISTING GROUND
- (H) HOT-MIX ASPHALT SURFACE REMOVAL - 2"
- (I) CURB REMOVAL
- (J) COMBINATION CURB AND GUTTER REMOVAL
- (K) PAVEMENT REMOVAL
- [Hatched Box] ITEM TO BE REMOVED

PROPOSED LEGEND

- (1) HOT-MIX ASPHALT SURFACE COURSE, MIX "D", NSO - 1 1/2"
- (2) HOT-MIX ASPHALT SURFACE COURSE, MIX "D", NSO - 2"
- (3) HOT-MIX ASPHALT BINDER COURSE, IL-19.0, NSO - 2 1/4"
- (4) LEVELING BINDER (MACHINE METHOD), NSO - 1"
- (5) COMBINATION CONCRETE CURB AND GUTTER, TYPE B-6.12
- (6) BASE COURSE REMOVAL (SPECIAL) AND AGGREGATE BASE COURSE, TYPE B (AS DETERMINED BY THE ENGINEER)
- (7) AGGREGATE BASE COURSE, TYPE B - 4"
- (8) AGGREGATE BASE COURSE, TYPE B (±1")
- (9) CLASS D PATCHES - 6" (AS DETERMINED BY THE ENGINEER)
- (10) CLASS D PATCHES - 4" (AS DETERMINED BY THE ENGINEER)
- (11) PREPARATION OF BASE
- (12) GRADING AND SHAPING SHOULDERS
- (13) AGGREGATE WEDGE SHOULDER, TYPE B
- (14) PORTLAND CEMENT CONCRETE SURFACE REMOVAL - BUTT JOINT
- (15) TOPSOIL FURNISH AND PLACE, 4"
- (16) SEEDING, CLASS 1A

COPYRIGHT © 2014 BY BAXTER & WOODMAN, INC.
 STATE OF ILLINOIS - PROFESSIONAL DESIGN FIRM
 LICENSE NO. 184-00289 - EXPIRES 4/30/2015
 201405 201405 5/23/2014
 I:\C:\yatel\c\w\140183_W0-1-TypSect.dgn

DESIGNED - DSH	REVISED - A 5-23-14
DRAWN - UKB	REVISED -
CHECKED - LDH	REVISED -
DATE - 05-06-14	FILE - 140183_W0-1-TypSect.dgn

STATE OF ILLINOIS
DEPARTMENT OF TRANSPORTATION

ILLINOIS YOUTH CENTER - ST. CHARLES
EXISTING AND PROPOSED TYPICAL SECTIONS

F.A. RTE.	SECTION	COUNTY	TOTAL SHEETS	SHEET NO.
347	2014-04RS	KANE	25	11
C-91-374-14			CONTRACT NO. 60Y37	
FED. ROAD DIST. NO. 1 ILLINOIS FED. AID PROJECT				

SCALE: NONE STA. TO STA.