

FLAP GATE (SPECIAL) 24"

TYPICAL DIMENSIONS IN INCHES

PIPE DIAMETER	A	B	C	D	N	S
12	13 1/4	15 7/8	18	13 1/4	4	5/8
15	16 1/4	19	21	16 1/4	4	5/8
18	19 1/4	22 1/8	24 1/4	19 1/4	4	3/4
21	22 1/4	25 1/8	27 1/4	22 1/4	4	3/4
24	25 1/4	28 1/4	30 1/4	25 1/4	6	3/4
27	28 1/4	31 1/4	33 1/4	28 1/4	6	7/8
30	31 1/4	34 1/4	36 1/2	31 1/4	6	7/8
36	37 1/4	41 1/2	43 1/2	37 1/2	6	7/8
42	43 1/2	47 1/2	49 1/2	43 1/2	6	7/8
48	49 1/2	54	56 1/2	49 1/2	6	1

GENERAL NOTES

THE FLAP GATE (SPECIAL) SHALL BE COMMERCIALY PRODUCED BY A RELIABLE MANUFACTURER. THE GATE MAY BE MADE OF CAST IRON, CAST STEEL, OR OTHER SUITABLE MATERIAL. THE DESIGN MAY DIFFER FROM THE DRAWING IF THE GATE WILL WORK IN A SATISFACTORY, TROUBLE FREE MANNER AND WILL WITHSTAND THE ANTICIPATED WATER PRESSURE. THE GATE SHALL BE APPROVED BY THE ENGINEER.

THE SIZE OF FLAP GATE (SPECIAL) REFERS TO THE DIAMETER OF THE PIPE.

THIS WORK SHALL BE PAID FOR AT THE CONTRACT UNIT PRICE EACH FOR **FLAP GATE (SPECIAL) XX"** OF THE SIZE SPECIFIED AND SHALL INCLUDE ALL LABOR AND MATERIALS NECESSARY TO COMPLETE THE INSTALLATION.

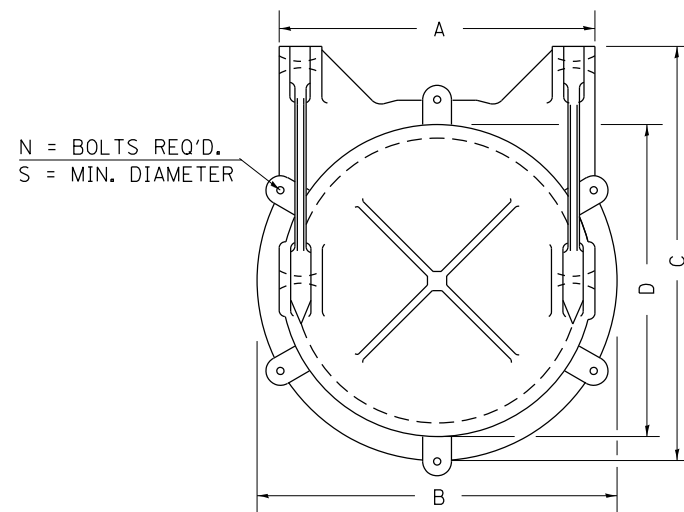

FRONT FACE

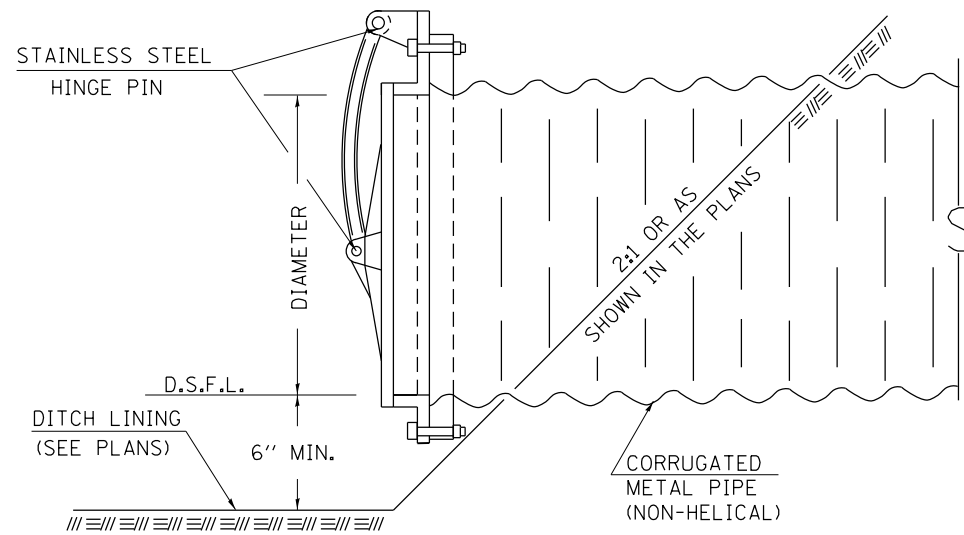

SECTION

GENERAL NOTES

- The work shall be done in accordance with Article 406.08 and the Special Provision for Butt Joints.
- The pavement surface to be removed may be either bituminous or P.C. concrete. The work shall be performed in accordance with Article 440.04 and the Special Provisions for Butt Joints.
- The saw cut joints shall be primed just prior to the placing of bituminous material. The work will be in accordance with the applicable portions of Article 406.05.

1 REPRESENTS STATION WHERE THE PROPOSED SURFACE ELEVATION MINUS THE EXISTING SURFACE ELEVATION EQUALS 0.125'.

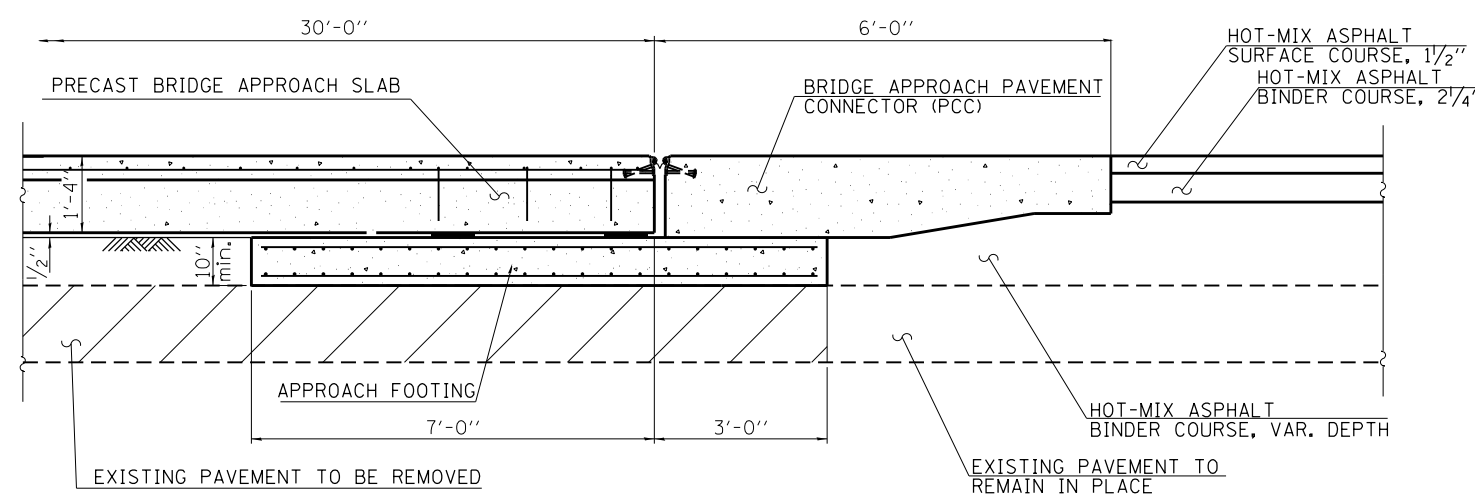

BRIDGE APPROACH PAVEMENT CONNECTOR DETAIL

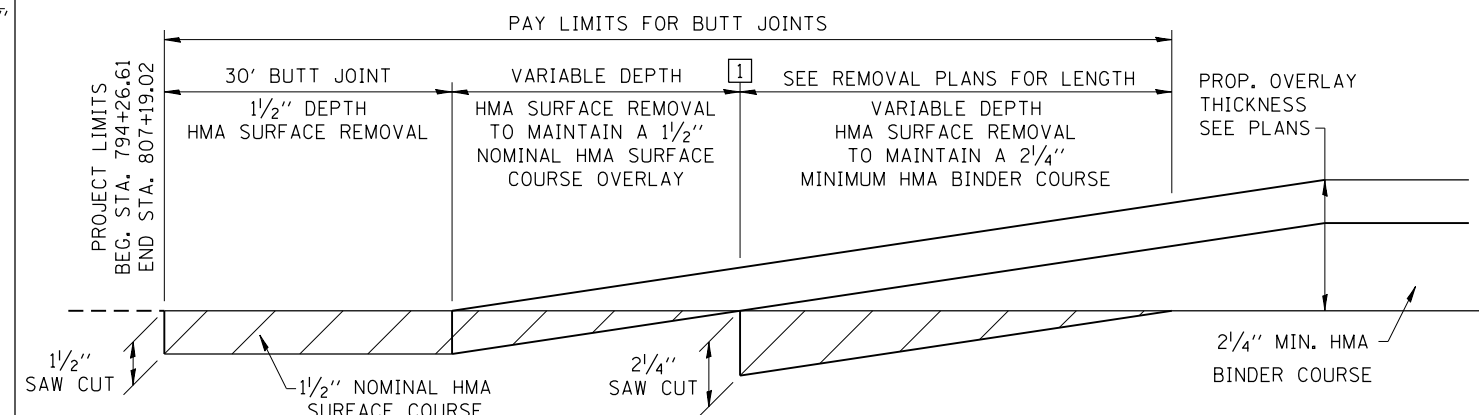

BUTT JOINT AND MILLING DETAIL
THIS DETAIL APPLIES TO THE BEGIN AND END OF PROJECT

FILE NAME =	USER NAME = bemery	DESIGNED -	REVISED -
P:\Projects\2008 Projects\08379 IL 8 over Kickapoo Creek\CV\CADD Sheets\0468697-sheet DRAWING.dgn		REVISOR -	REVISOR -
PLOT SCALE = 100.0000' / 1in.	CHECKED -	REVISOR -	REVISOR -
PLOT DATE = 3/20/2014	DATE -	REVISOR -	REVISOR -

STATE OF ILLINOIS
DEPARTMENT OF TRANSPORTATION

DETAILS	
IL 8 OVER KICKAPOO CREEK	
NOT TO SCALE	SHEET NO. 1 OF 13 SHEETS
STA.	TO STA.

F.A.S. RTE.	SECTION	COUNTY	TOTAL SHEETS	SHEET NO.
1388	(Z-1D-BR-1)BR	PEORIA	89	30
CONTRACT NO. 68697				
FED. ROAD DIST. NO. ILLINOIS FED. AID PROJECT				