

SECTION E-E

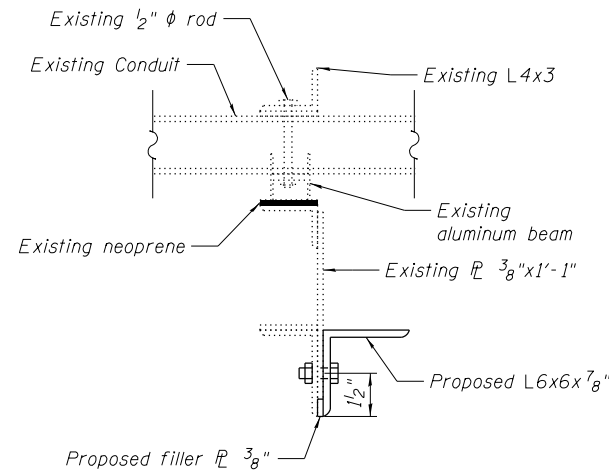

SECTION F-F
(cross section at H-6)

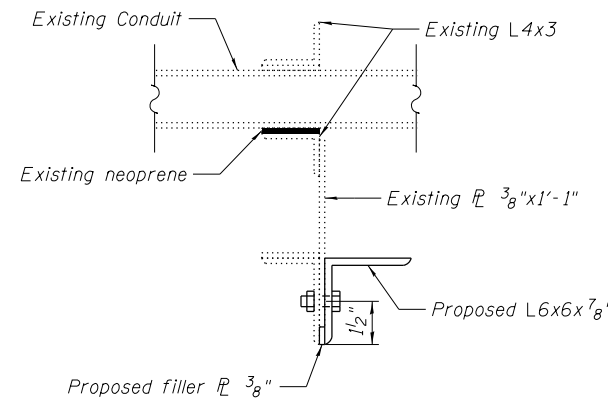

SECTION F-F
(cross section at H-12)

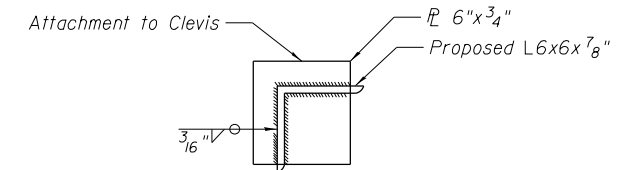

SECTION H-H

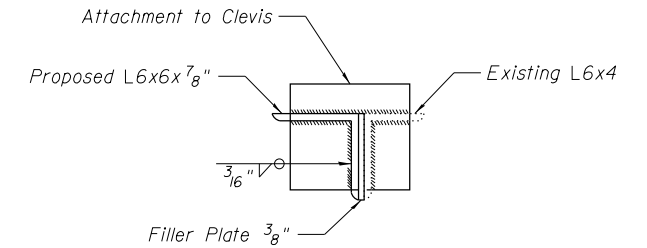

SECTION I-I

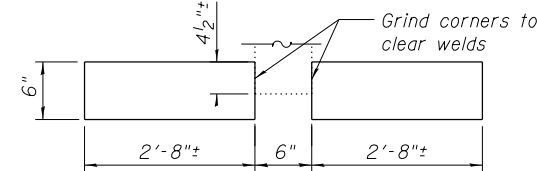

FILLER PLATES 3/8"

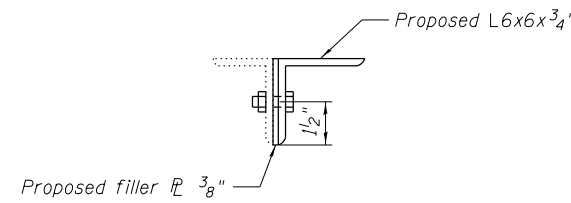

SECTION G-G

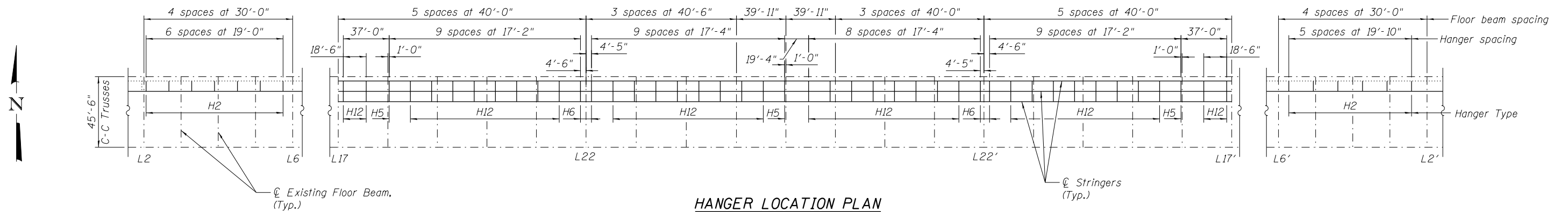

HANGER LOCATION PLAN

Notes:

The Contractor is to verify the existing dimensions prior to fabricating the support assembly. The existing details shown here are derived from the existing plans. It is intended to keep the utility conduit at the current elevation.

Hangers H5 are connected to floor beams and no change is expected to the support assembly.

All hanger assemblies required including angles, eye rods, end plates and fasteners are included in the price of Conduit Support System.

If Contractor chooses to use different configurations for temporary support than shown on sheets S025 thru S027, then plans showing revised configuration shall be submitted to Bridge Office for review.

See Sheet S061 of S138 for stringer repairs at L2 thru L6 and L2' thru L6'.

See Sheet S014 of S138 for stringer replacements between L17 and L17'.

MODIFICATION SEQUENCE FOR H6 & H12

1. Extend bottom support angle and hang from truss chord.
2. Remove attachment to exterior stringer S1.
3. Replace all existing stringers except interior stringer S2.
4. Attach to proposed stringers S1 and S3.
5. Replace interior stringer S2.

BILL OF MATERIAL

Item	Unit	Total
Conduit Support System	L Sum	1

(Sheet 3 of 3)