

VIEW D-D

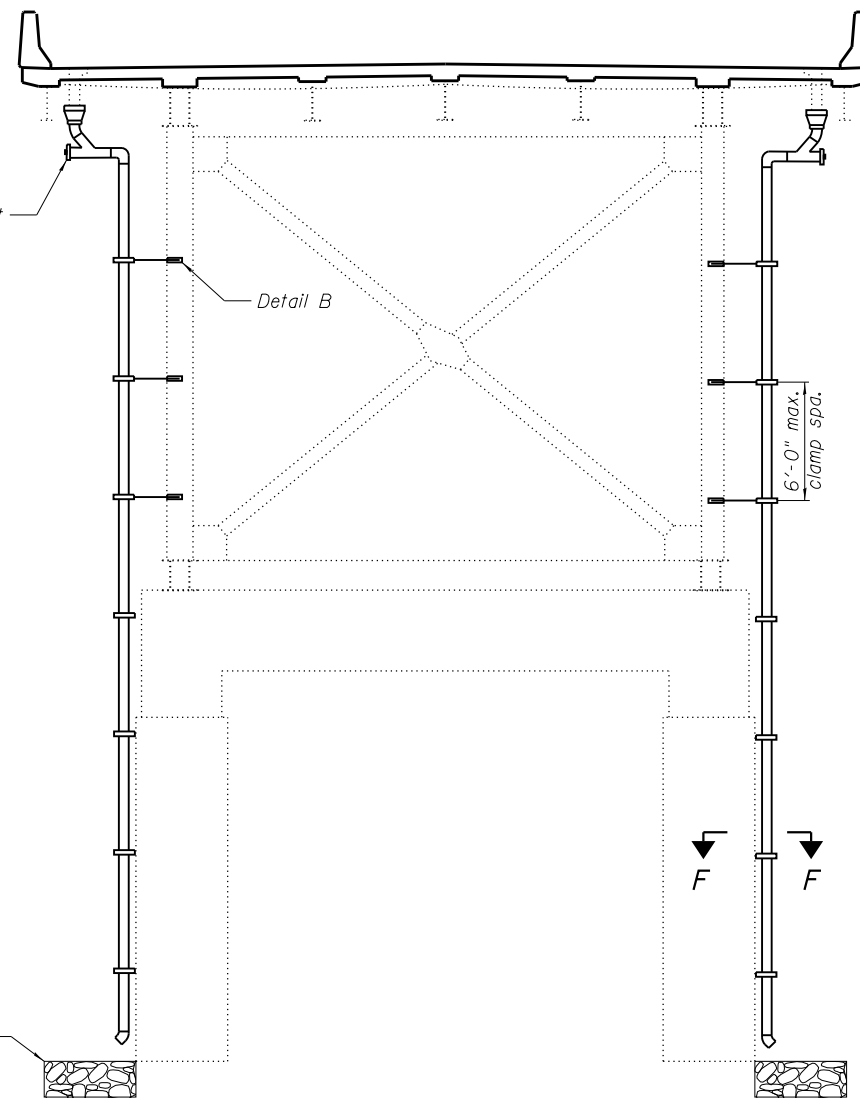

VIEW E-E

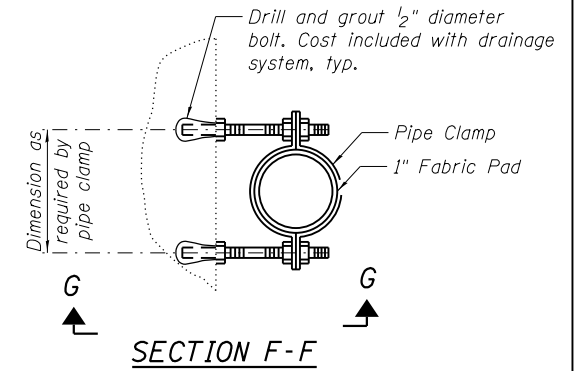

SECTION F-F

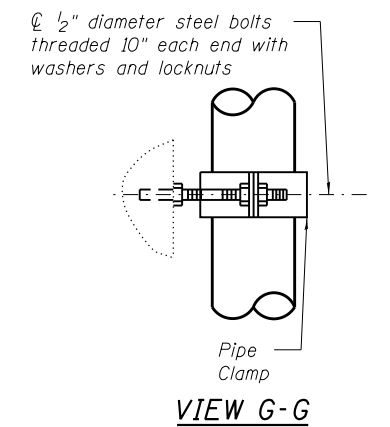

VIEW G-G

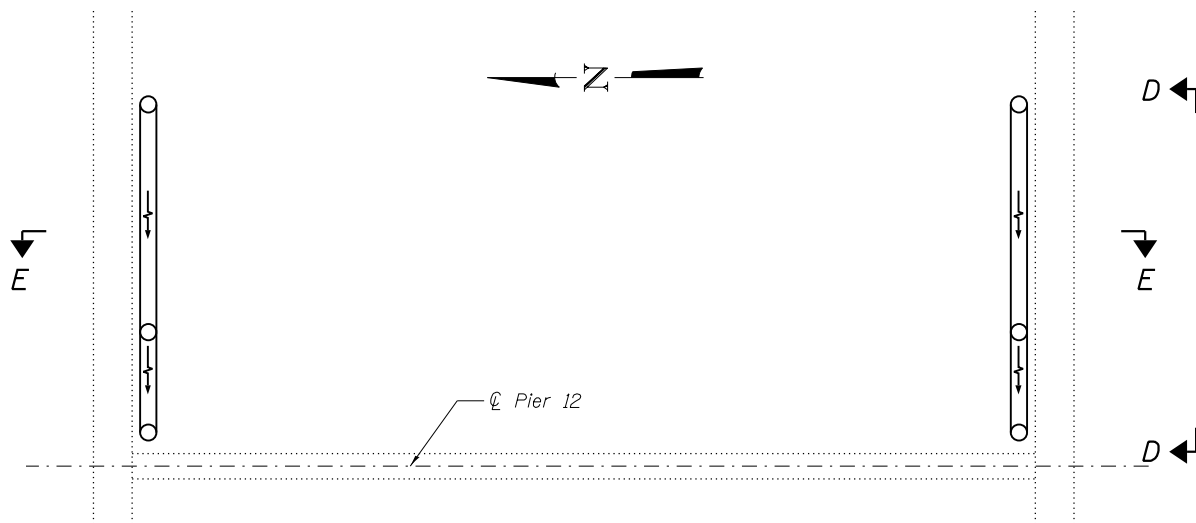

DRAINAGE PLAN AT PIER 12

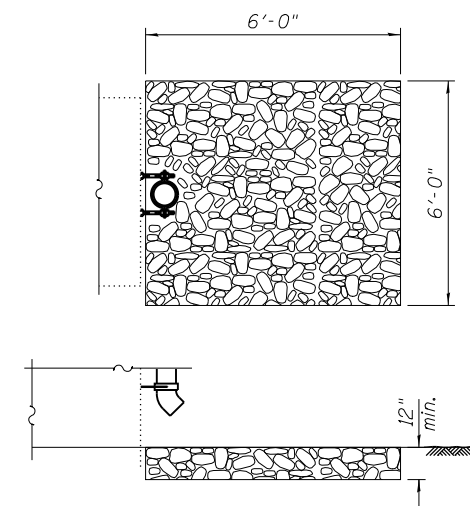

STONE RIPRAP CHECK BASIN DETAIL

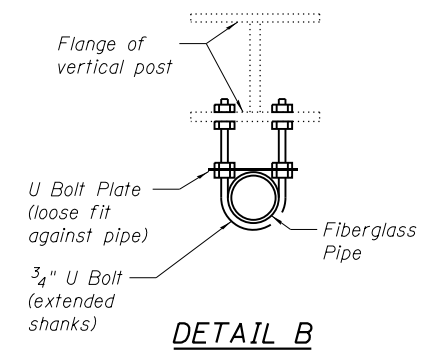

DETAIL B

Notes:
 The areas where the pipe collector system flows opposite the bridge profile, the typical height shall be adjusted to meet a minimum 0.5% slope to drain.
 See sheet S129 of S138 for Detail A, 90° elbow and Tee details at collector pipes.
 All downspouts from scuppers shall be 8" unless otherwise noted.
 All pipe clamps, fabric pads, inserts, collectors and other work necessary to install the system shall be considered included with the cost of the pay item Drainage System.
 All fiberglass pipe shall conform to ASTM D 2996 with a short-time rupture strength hoop tensile stress of 30,000 psi min. Color shall be concrete gray.

BILL OF MATERIAL

Item	Unit	Total
Drainage System	L Sum	1

(Sheet 2 of 2)