

DETAIL FOR HMA SURFACE REMOVAL - BUTT JOINT

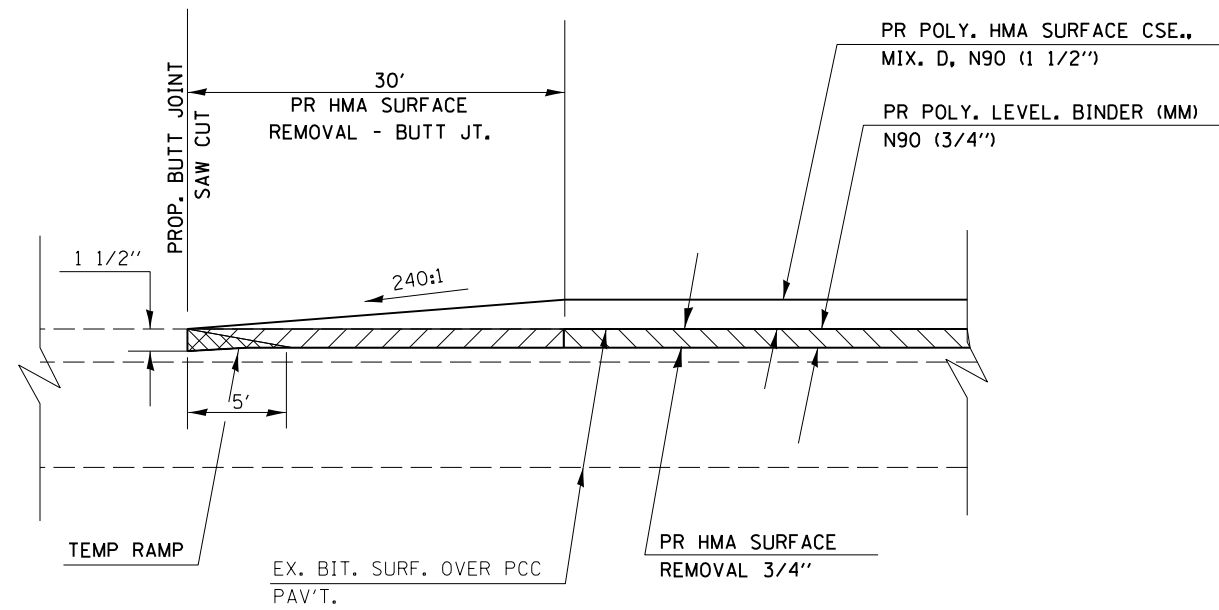

TO BE USED:
STA. 1060+67 (BEGINNING OF PROJECT)

DETAIL FOR HMA SURFACE TRANSITION OVER EXISTING PCC PAVEMENT

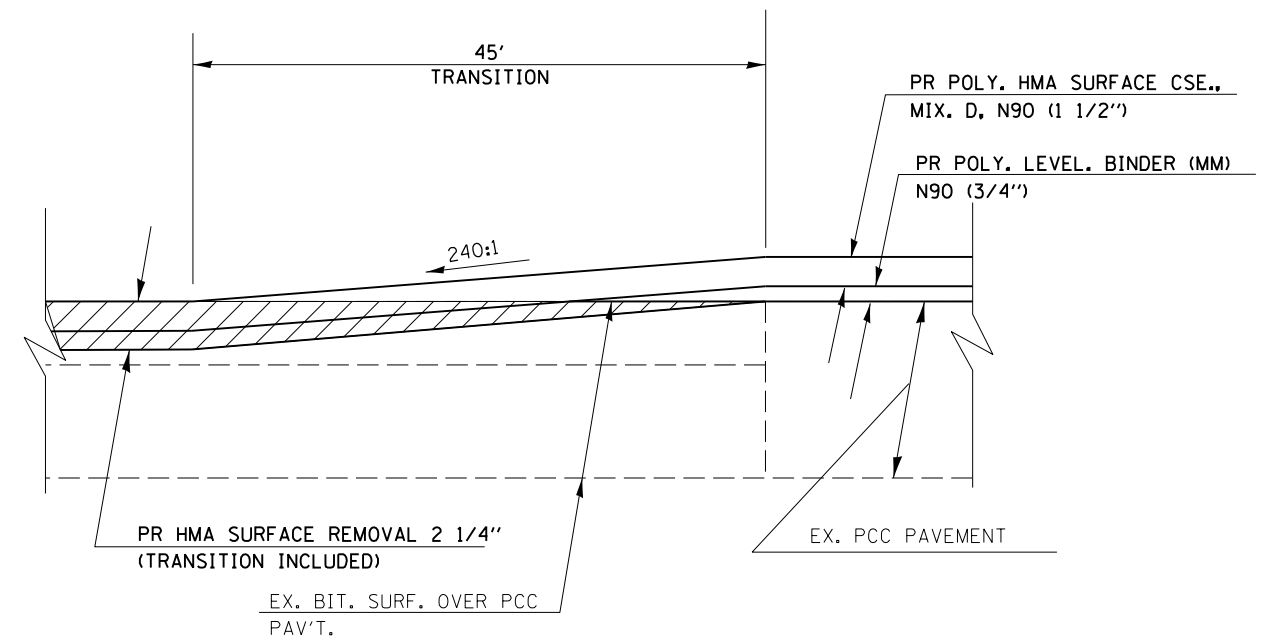

TO BE USED:
STA. 1030+75 TO STA. 1031+26
STA. 1134+47 TO STA. 1134+92

DETAIL FOR HMA SURFACE REMOVAL TRANSITION FROM 3/4" TO 2 1/4"

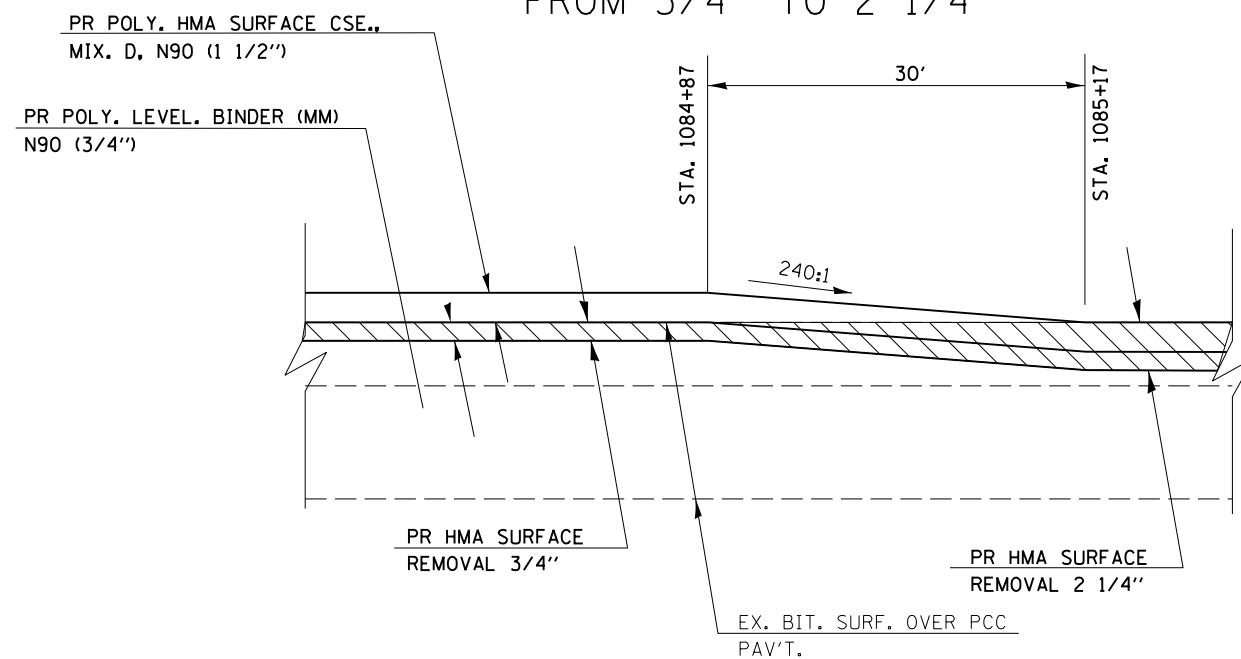

TO BE USED:
STA. 1084+87 TO STA. 1085+17
TRANSITION FROM 3/4" MILLING
TO 2 1/4" MILLING INLAY.

DETAIL FOR HMA SURFACE REMOVAL INLAY AND JOINT SAW CUT

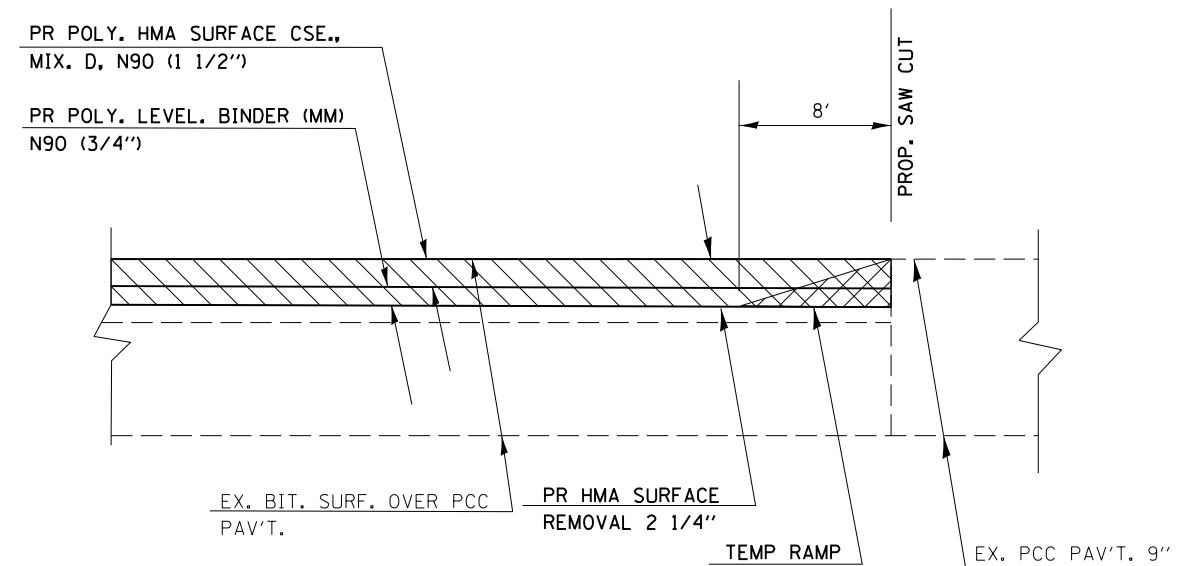

TO BE USED:
STA. 1137+25

FILE NAME =	USER NAME = mccordkr	DESIGNED -	REVISED -
et:\pwork\pwork\mccordkr\10381606\78404-sh-t-plan.dgn		DRAWN -	REVISED -
		CHECKED -	REVISED -
		DATE -	REVISED -

STATE OF ILLINOIS
DEPARTMENT OF TRANSPORTATION

DETAIL - BUTT JOINTS AND MILLING TRANSITIONS			
SCALE:	SHEET NO.	OF SHEETS	STA. TO STA.

F.A. RTE.	SECTION	COUNTY	TOTAL SHEETS	SHEET NO.
	41RS-7	MASSAC	29	24
CONTRACT NO. 78404				
ILLINOIS FED. AID PROJECT				