

**GENERAL**

- THE CONTRACTOR AND ALL SUBCONTRACTORS SHALL FOLLOW THE REQUIREMENTS OF THE AIRPORT'S APPROVED CONSTRUCTION SAFETY AND PHASING PLAN (CSPP), FAA AC 150/5370-2F (LATEST EDITION), AND ALL AIRPORT SAFETY AND SECURITY REQUIREMENTS.
- PRIOR TO THE START OF CONSTRUCTION THE CONTRACTOR SHALL SUBMIT TO THE AIRPORT FOR APPROVAL A SAFETY PLAN COMPLIANCE DOCUMENT (SPCD) IN ACCORDANCE WITH FAA AC 150/5370-2F. NO CONSTRUCTION ACTIVITY SHALL BEGIN UNTIL THE AIRPORT HAS APPROVED THE SPCD.
- THE CSPP COVERS OPERATIONAL SAFETY. THE CONTRACTOR SHALL BE RESPONSIBLE FOR THE INDIVIDUAL SAFETY OF HIS/HER PERSONNEL AND MEETING OSHA REQUIREMENTS.
- A MINIMUM OF 10 DAYS PRIOR TO THE PRECONSTRUCTION MEETING THE CONTRACTOR SHALL PROVIDE A LIST OF SUBCONTRACTORS AND MATERIAL SUPPLIERS.
- ALL CONTRACTOR COSTS ASSOCIATED WITH THE REQUIREMENTS LISTED ON THIS SHEET SHALL BE CONSIDERED INCIDENTAL TO THE CONTRACT UNLESS A SPECIFIC PAY ITEM IS PROVIDED.

**1. COORDINATION**

- PRIOR TO THE START OF CONSTRUCTION THE CONTRACTOR SHALL ATTEND A PRECONSTRUCTION CONFERENCE WITH THE AIRPORT, AND ENGINEER. THE COST OF PREPARING FOR AND ATTENDING THE PRECONSTRUCTION CONFERENCE SHALL BE INCIDENTAL TO THE CONTRACT.
- ON OR BEFORE THE PRECONSTRUCTION CONFERENCE, THE CONTRACTOR SHALL SUBMIT A PROPOSED SCHEDULE FOR THE PROJECT. THE SCHEDULE SHALL INCLUDE A START AND COMPLETION DATE FOR EACH ITEM OF WORK. THE SCHEDULE SHALL BE UPDATED ON A WEEKLY BASIS. ALL COSTS ASSOCIATED WITH THE SCHEDULE SHALL BE INCIDENTAL TO THE CONTRACT.
- DURING CONSTRUCTION THE CONTRACTOR SHALL ATTEND A WEEKLY COORDINATION MEETING WITH THE AIRPORT AND RESIDENT ENGINEER. ALL COSTS ASSOCIATED WITH ATTENDING THE WEEKLY MEETING SHALL BE INCIDENTAL TO THE CONTRACT.

**2. PHASING**

- TOTAL CONTRACT TIME SHALL BE 54 CALENDAR DAYS. SHOULD ADDITIVE ALTERNATE #1 BE AWARDED 2 ADDITIONAL CALENDAR DAYS WILL BE ADDED TO CONTRACT.
- THE PROJECT HAS TWO PHASES. PHASE 1 WORK CONSISTS OF REMOVAL OF THE EXISTING TIE DOWNS AND GROUND RODS, MILLING AND BITUMINOUS PAVING, AND INSTALLATION OF NEW TIE DOWNS, GROUND RODS, MARKING AND SHOULDER ADJUSTMENT. PHASE 2 WORK CONSISTS OF MILLING AND BITUMINOUS PAVING, REMOVAL AND REPLACEMENT OF PCC PAVEMENT IF ADD ALT #1 IS AWARDED, INSTALLATION OF NEW PAVEMENT MARKINGS AND SHOULDER ADJUSTMENT.

**3. AREAS AND OPERATIONS AFFECTED BY THE CONSTRUCTION ACTIVITY**

- ALL RUNWAYS, TAXIWAYS AND APRONS SHALL BE KEPT OPEN TO AIRCRAFT TRAFFIC DURING CONSTRUCTION EXCEPT AS NOTED.
- WHEN CONFLICTS ARISE BETWEEN CONSTRUCTION ACTIVITIES AND AIRCRAFT OPERATIONS AND SAFETY, AIRCRAFT OPERATIONS AND SAFETY SHALL TAKE PRECEDENCE AND SHALL GOVERN. FINAL AUTHORITY IN THE APPROVAL OF CONSTRUCTION SEQUENCING LIES WITH THE AIRPORT.
- ALL CONSTRUCTION TRAFFIC SHALL IMMEDIATELY YIELD TO ONCOMING AIRCRAFT AT ALL TIMES.

**4. PROTECTION OF NAVIGATION AIDS (NAVAIDS)**

- CONTRACTOR SHALL COORDINATE WITH THE AIRPORT A MINIMUM OF 10 DAYS PRIOR TO THE SHUT DOWN OF ANY NAVIGATIONAL AIDS.

**5. CONTRACTOR ACCESS**

- CONTRACTOR ACCESS SHALL BE AS SHOWN ON THE SITE PLAN AND CONSTRUCTION ACTIVITY PLAN SHEETS.
- THE CONTRACTOR IS TO ACCESS THE SITE USING THE GATES SHOWN.
- THE TRUCK DRIVERS SHALL BE ESCORTED BY THE CONTRACTOR AT ALL TIMES.
- CONTRACTOR WORK CREWS MUST MONITOR AIRFIELD RADIO FREQUENCY (122.80) AT ALL TIMES WHEN INSIDE THE AIRPORT OPERATIONS AREA (AOA).
- THE CONTRACTORS STORAGE AND STAGING AREA WILL BE AS SHOWN IN THE SITE PLAN
- THE CONTRACTOR SHALL KEEP A RECORD OF THE NAMES OF ALL EMPLOYEES ENTERING THE JOB SITE ON A DAILY BASIS. A RECORD OF EACH SUBCONTRACTOR ENTERING THE JOB SITE SHALL ALSO BE KEPT BY THE CONTRACTOR.
- WHEN THE CONTRACTOR IS NOT WORKING, EQUIPMENT SHALL BE STORED AT THE STAGING AREA.
- THE CONTRACTOR WILL BE PERMITTED TO STORE EQUIPMENT AND MATERIALS ONLY AT THE LOCATIONS SHOWN. PARKED EQUIPMENT AND MATERIAL STOCKPILES SHALL NOT PENETRATE SURFACES DEFINED BY F.A.R. TITLE 14 PART 77 - OBJECTS AFFECTING NAVIGABLE AIRSPACE.
- THE CONTRACTOR SHALL THOROUGHLY CLEAN ALL CONSTRUCTION AREAS AND HAUL ROUTES, INCLUDING ALL COUNTY ROADS WHICH WILL BE OPEN TO TRAFFIC TO THE SATISFACTION OF AIRPORT OPERATIONS AND THE COUNTY ENGINEER. A POWER BROOM AND OPERATOR SHALL BE ON SITE AT ALL TIMES WHEN ACTIVE PAVEMENTS ARE UTILIZED FOR CONSTRUCTION TRAFFIC.
- ALL PAVEMENTS, DRIVES, TURF AREAS, OR ANY OTHER AREAS UTILIZED BY THE CONTRACTOR FOR HAUL ROADS OR STORAGE AREAS SHALL BE MAINTAINED AND REPAIRED TO THE SAME CONDITION OR BETTER THAN THEY WERE PRIOR TO BEGINNING CONSTRUCTION. NO ADDITIONAL COMPENSATION WILL BE MADE TO THE CONTRACTOR FOR THIS WORK.
- ALL VEHICLE AND EQUIPMENT OPERATORS USED BY THE CONTRACTOR SHALL BE PROPERLY TRAINED BY THE CONTRACTOR.
- THE CONTRACTOR SHALL NOTIFY THE AIRPORT IF CONSTRUCTION ACTIVITY WILL REQUIRE THE BLOCKAGE OF EMERGENCY ACCESS TO THE AIRPORT.

**6. WILDLIFE MANAGEMENT**

- THE CONTRACTOR SHALL NOTIFY AIRPORT OPERATIONS OR THE ENGINEER IF ANY WILDLIFE IS SEEN ENTERING THE AIRPORT.
- CONTRACTOR ACCESS GATES SHALL REMAIN CLOSED WHEN THE CONTRACTOR IS NOT WORKING.
- THE CONTRACTOR SHALL DISPOSE OF ALL TRASH INCLUDING FOOD SCRAPS IN APPROVED CONTRACTOR PROVIDED CONTAINERS.

**7. FOREIGN OBJECT DEBRIS (FOD) MANAGEMENT**

- THE CONTRACTOR SHALL PICK UP ANY FOREIGN OBJECT DEBRIS (FOD) SEEN ON THE AIRFIELD PAVEMENTS.
- THE CONTRACTOR SHALL SECURE ALL LOOSE ITEMS FROM VEHICLES PRIOR TO DRIVING ON AIRFIELD PAVEMENTS.

**8. HAZARDOUS MATERIALS (HAZMAT) MANAGEMENT**

- THE CONTRACTOR SHALL DEVELOP A HAZMAT MANAGEMENT PLAN AND KEEP COPIES ON THE JOBSITE OF MATERIAL SAFETY DATA SHEETS (MSDS) FOR ALL MATERIALS HANDLED ON THE JOBSITE.

**9. NOTIFICATION OF CONSTRUCTION ACTIVITIES**

- THE CONTRACTOR SHALL PROVIDE A 24 HOUR EMERGENCY CONTACT PERSON AND PHONE NUMBER.
- THE CONTRACTOR SHALL GIVE A MINIMUM OF 72 HOURS NOTICE TO AIRPORT OPERATIONS PRIOR TO CLOSING ANY PAVEMENTS SO THAT PROPER NOTAMS MAY BE ISSUED BY THE AIRPORT.
- FOR ANY EQUIPMENT USED BY THE CONTRACTOR WITH A HEIGHT GREATER THAN 25', THE CONTRACTOR SHALL PROVIDE TO THE AIRPORT THE TYPE OF EQUIPMENT, TOTAL HEIGHT, AND LOCATION WHERE THE EQUIPMENT WILL BE USED. THE AIRPORT WILL SUBMIT FAA FORM 7460-1 TO THE FAA FOR AN AIRSPACE STUDY. NO EQUIPMENT WITH A HEIGHT GREATER THAN 25' SHALL BE USED UNTIL A DETERMINATION FROM FAA IS RECEIVED.
- IN THE EVENT OF AN EMERGENCY, THE CONTRACTOR SHALL CALL 911.
- CONTACTS FOR THIS PROJECT ARE AS LISTED BELOW.

<b>PUBLIC SAFETY</b>	
FIRE AND PUBLIC SAFETY	911
<b>PONTIAC AIRPORT</b>	(815) 844-2707
<b>RESIDENT ENGINEER</b>	TBD

**10. INSPECTION REQUIREMENTS**

- THE CONTRACTOR SHALL INSPECT THE JOBSITE DAILY TO ENSURE COMPLIANCE WITH THE CSPP. THE CHECKLIST FOUND IN APPENDIX 3 OF FAA AC 150/5370-2F MAY BE USED TO AID IN THE INSPECTIONS.
- THE CONTRACTOR SHALL ATTEND A FINAL INSPECTION OF EACH PHASE WORK AREA PRIOR TO OPENING THE AREA TO AIRPORT OPERATIONS.

**11. UNDERGROUND UTILITIES**

- IT WILL BE NECESSARY FOR THE CONTRACTOR TO MAKE HIS OWN FIELD INVESTIGATION TO DETERMINE THE EXACT LOCATION OF THE UNDERGROUND UTILITIES AT CRITICAL POINTS. THE LOCATION OF UNDERGROUND UTILITIES AS INDICATED ON THE PLANS HAS BEEN OBTAINED FROM EXISTING RECORDS. NEITHER THE OWNER NOR THE ENGINEER ASSUMES ANY RESPONSIBILITY IN RESPECT TO THE ACCURACY, COMPLETENESS OR SUFFICIENCY OF THE INFORMATION.
- BEFORE INITIATING ANY DIGGING, DRILLING OR EXCAVATING ON THE AIRPORT PROPERTY, THE CONTRACTOR SHALL CALL J.U.L.I.E. AND CONTACT THE LOCAL FAA OFFICE TO ARRANGE FOR UTILITY LOCATES.

**12. PENALTIES**

- NONCOMPLIANCE BY THE CONTRACTOR WITH AIRPORT RULES AND REGULATIONS OR FAILURE TO COMPLY WITH THE AIRPORT'S APPROVED CSPP AND THE CONTRACTOR'S APPROVED SPCD MAY RESULT IN FINES AS ALLOWED BY LAW.

**13. SPECIAL CONDITIONS**

- CONTRACTOR SHALL COORDINATE WITH COUNTY ENGINEER FOR ACCESS AND EGRESS ON ALL COUNTY ROADS. ANY DAMAGE TO COUNTY ROADS FROM THE CONTRACTORS OPERATIONS SHALL BE REPAIRED IN KIND AT THE CONTRACTOR'S EXPENSE.

**14. RUNWAY AND TAXIWAY VISUAL AIDS**

- RUNWAY AND/OR TAXIWAY CLOSURES ARE REQUIRED FOR THIS PROJECT. ALL RUNWAY OR TAXIWAY CLOSURES REQUESTED BY THE CONTRACTOR AND APPROVED BY THE AIRPORT, THE CONTRACTOR SHALL USE MARKING, LIGHTING AND SIGNS THAT FOLLOWING THE REQUIREMENTS OF FAA AC 150/5370-2F.

**15. MARKING AND SIGNS FOR ACCESS ROUTES**

- CONTRACTOR SHALL CLEARLY MARK ALL ACCESS AND HAUL ROUTES.

**16. HAZARD MARKING AND LIGHTING**

- THE CONTRACTOR SHALL FURNISH, ERECT, AND MAINTAIN MARKINGS AND ASSOCIATED LIGHTING OF OPEN TRENCHES, EXCAVATIONS, TEMPORARY STOCKPILES, AND HIS/HER CONSTRUCTION EQUIPMENT.
- ALL CONSTRUCTION EQUIPMENT SHALL BE FLAGGED AND/OR LIGHTED IN ACCORDANCE WITH FAA ADVISORY CIRCULAR 150/5370-2F AND 150/5210-5C AT ALL TIMES WHILE OPERATING ON AIRPORT PROPERTY. THE MAXIMUM EQUIPMENT HEIGHT IS 25' UNLESS OTHERWISE COORDINATED WITH THE AIRPORT.
- BARRICADES SHALL BE PLACED AT THE LOCATIONS SHOWN ON THE CONSTRUCTION ACTIVITY PLAN SHEET OR AS DIRECTED BY THE ENGINEER.
- THE CONTRACTOR SHALL INSPECT THE BARRICADES ONCE DURING EACH WORK DAY TO INSURE PROPER PLACEMENT AND PROPER OPERATION OF THE RED LIGHTS.

**17. PROTECTION**

- ALL WORK WITHIN THE SAFETY AREA AND RUNWAY OBJECT FREE ZONE (ROFZ) OF THE RUNWAY WILL REQUIRE THE RUNWAY TO BE CLOSED. THE CONTRACTOR MAY CLOSE THE RUNWAY ON A DAILY BASIS WITH COORDINATION AND APPROVAL OF THE AIRPORT. THE CONTRACTOR SHALL PLACE RUNWAY CLOSURE MARKERS OVER THE NUMERALS AT EACH END OF THE RUNWAY. THE CONTRACTOR WILL ALSO BE REQUIRED TO PLACE BARRICADES AS SHOWN ON THE PLANS. THE CONTRACTOR SHALL ALSO TAKE CONTROL AND LOCKOUT ALL AIRFIELD LIGHTING PRIOR TO CLOSURE OF THE RUNWAY. AT THE END OF EACH WORKDAY THE THESE MARKERS AND BARRICADES SHALL BE REMOVED AND THE RUNWAY REOPENED. THE CONTRACTOR SHALL ALSO RETURN CONTROL OF THE AIRFIELD LIGHTING TO THE AIRPORT. COST OF RUNWAY CLOSURE MARKERS, BARRICADES, LOCKOUT OF ELECTRICAL SYSTEM, SET UP/TAKE DOWN OF RUNWAY CLOSURE MARKER, BARRICADES AND LOCKOUT OF ELECTRICAL SYSTEM SHALL BE INCIDENTAL TO THE PROJECT.
- NO OPEN TRENCHES WILL BE ALLOWED WITHIN THE SAFETY AREA OF THE RUNWAY WHILE THE RUNWAY IS OPEN.

**18. OTHER LIMITATIONS ON CONSTRUCTION**

- IF, DURING CONSTRUCTION, AN EMERGENCY IS DECLARED BY THE AIRPORT, THE CONTRACTOR SHALL IMMEDIATELY CLEAR THE PAVEMENT OF ALL VEHICLES, PERSONNEL AND EQUIPMENT.
- BROKEN CONCRETE, BROKEN ASPHALT, AND OTHER MISCELLANEOUS DEBRIS SHALL BE DISPOSED OF OFF AIRPORT PROPERTY, UNLESS OTHERWISE SPECIFIED.

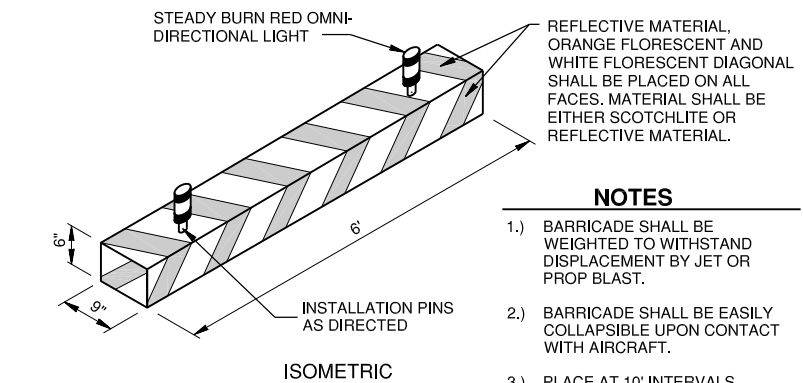
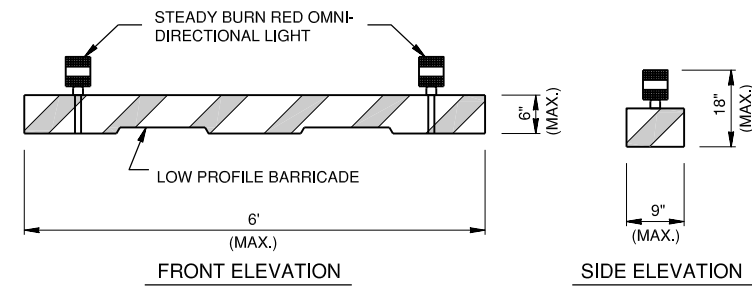

**BEAM BARRICADE DETAILS**  
N.T.S.

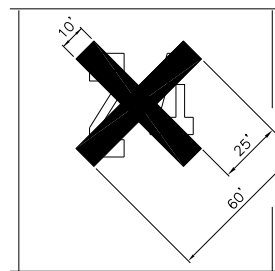

**ON PAVEMENT CLOSED RUNWAY MARKER DETAIL**  
N.T.S.

**NOTES**

- MARKERS SHALL BE SOLID YELLOW.
- MARKERS SHALL BE PAINTED PLYWOOD OR OTHER APPROVED SOLID MATERIALS, WEIGHTED DOWN TO PREVENT MOVEMENT.
- CONTRACTOR SHALL MAINTAIN MARKERS.
- COST OF FURNISHING, INSTALLING, MAINTAINING, RELOCATING AND REMOVING MARKERS SHALL BE INCIDENTAL TO THE CONTRACT.
- MARKERS SHALL BE PLACED OVER EXISTING RUNWAY NUMERALS.

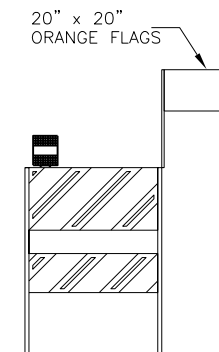

**FLASHER BARRICADE DETAIL**  
N.T.S.

**BARRICADE NOTES**

- RED LIGHTS TO BE BATTERY OPERATED. LIGHTS TO BE STEADY BURN RED OMNI-DIRECTIONAL.
- SANDBAGS TO BE PLACED ON EACH SUPPORT BRACE AS REQUIRED TO PREVENT DISPLACEMENT BY WIND, JET OR PROP BLAST.
- NO SEPARATE PAYMENT WILL BE MADE FOR THIS ITEM. COSTS SHALL BE CONSIDERED INCIDENTAL TO THE PROJECT.
- PLACE AT 10' INTERVALS.

**P0018**

REVISIONS		
NUMBER	BY	DATE
1	JEF	05/22/14

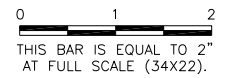

**NOTES**

- BARRICADE SHALL BE WEIGHTED TO WITHSTAND DISPLACEMENT BY JET OR PROP BLAST.
- BARRICADE SHALL BE EASILY COLLAPSIBLE UPON CONTACT WITH AIRCRAFT.
- PLACE AT 10' INTERVALS.
- NO SEPARATE PAYMENT WILL BE MADE FOR THIS ITEM. COSTS SHALL BE CONSIDERED INCIDENTAL TO THE PROJECT.

PONTIAC MUNICIPAL AIRPORT  
PONTIAC, ILLINOIS

REHABILITATE APRON AND CONNECTING TAXIWAY

CONSTRUCTION ACTIVITY PLAN NOTES AND DETAILS

© Copyright, CMT, Inc.  
**CMT**  
CRAWFORD, MURPHY & TILLY, INC.  
CONSULTING ENGINEERS  
License No. 184-000613

DESIGN BY:	JEF
DRAWN BY:	JEF, ADD
CHECKED BY:	RJH
APPROVED BY:	JEF
DATE:	APRIL 18, 2014
JOB No:	1305402

IL PROJ. NO. PNT-4142  
AIP PROJ. NO. 3-17-SBGp-XX