

**GENERAL**

- THE CONTRACTOR AND ALL SUBCONTRACTORS SHALL FOLLOW THE REQUIREMENTS OF THE AIRPORT'S APPROVED CONSTRUCTION SAFETY AND PHASING PLAN (CSPP) FOR THIS PROJECT, FAA AC 150/5370-2F, AND ALL AIRPORT SAFETY AND SECURITY REQUIREMENTS.
- PRIOR TO THE START OF CONSTRUCTION THE CONTRACTOR SHALL SUBMIT TO THE AIRPORT FOR APPROVAL A SAFETY PLAN COMPLIANCE DOCUMENT (SPCD) IN ACCORDANCE WITH FAA AC 150/5370-2F. NO CONSTRUCTION ACTIVITY SHALL BEGIN UNTIL THE AIRPORT HAS APPROVED THE SPCD.
- THE CSPP COVERS OPERATIONAL SAFETY. THE CONTRACTOR SHALL BE RESPONSIBLE FOR THE INDIVIDUAL SAFETY OF HIS/HER PERSONNEL AND MEETING OSHA REQUIREMENTS.
- A MINIMUM OF 10 DAYS PRIOR TO THE PRECONSTRUCTION MEETING THE CONTRACTOR SHALL PROVIDE A LIST OF SUBCONTRACTORS AND MATERIAL SUPPLIERS.
- PRIOR TO THE START OF CONSTRUCTION THE CONTRACTOR SHALL SIGN THE STORM WATER POLLUTION PREVENTION PROGRAM (SWPPP) CERTIFICATION STATEMENT.
- ALL CONTRACTOR COSTS ASSOCIATED WITH THE REQUIREMENTS LISTED ON THIS SHEET SHALL BE CONSIDERED INCIDENTAL TO THE CONTRACT UNLESS A SPECIFIC PAY ITEM IS PROVIDED.

**1. COORDINATION**

- PRIOR TO THE START OF CONSTRUCTION THE CONTRACTOR SHALL ATTEND A PRECONSTRUCTION CONFERENCE WITH THE AIRPORT, ENGINEER, AND ILLINOIS DIVISION OF AERONAUTICS (IDA). THE COST OF PREPARING FOR AND ATTENDING THE PRECONSTRUCTION CONFERENCE SHALL BE INCIDENTAL TO THE CONTRACT.
- ON OR BEFORE THE PRECONSTRUCTION CONFERENCE, THE CONTRACTOR SHALL SUBMIT A PROPOSED SCHEDULE FOR THE PROJECT. THE SCHEDULE SHALL INCLUDE A START AND COMPLETION DATE FOR EACH ITEM OF WORK. THE SCHEDULE SHALL BE UPDATED ON AS NEEDED BASIS. ALL COSTS ASSOCIATED WITH THE SCHEDULE SHALL BE INCIDENTAL TO THE CONTRACT.
- DURING CONSTRUCTION THE CONTRACTOR SHALL ATTEND A COORDINATION MEETINGS WITH THE AIRPORT STAFF AND RESIDENT ENGINEER. ALL COSTS ASSOCIATED WITH ATTENDING THE WEEKLY MEETING SHALL BE INCIDENTAL TO THE CONTRACT.

**2. PHASING**

- PHASING SHALL BE AS NOTED AND AS SHOWN ON THE CONSTRUCTION ACTIVITY PLAN SHEET.

**3. AREAS AND OPERATIONS AFFECTED BY THE CONSTRUCTION ACTIVITY**

- ALL RUNWAYS, TAXIWAYS AND APRONS SHALL BE KEPT OPEN TO AIRCRAFT TRAFFIC DURING CONSTRUCTION EXCEPT AS NOTED ON THE PHASING PLAN.
- WHEN CONFLICTS ARISE BETWEEN CONSTRUCTION ACTIVITIES AND AIRCRAFT OPERATIONS AND SAFETY, AIRCRAFT OPERATIONS AND SAFETY SHALL TAKE PRECEDENCE AND SHALL GOVERN. FINAL AUTHORITY IN THE APPROVAL OF CONSTRUCTION SEQUENCING LIES WITH THE AIRPORT.
- ALL CONSTRUCTION TRAFFIC SHALL IMMEDIATELY YIELD TO ONCOMING AIRCRAFT AT ALL TIMES.

**4. PROTECTION OF NAVIGATION AIDS (NAVAIDS)**

- THE CONTRACTOR SHALL REMAIN CLEAR OF THE NAVAIDS FACILITIES AT ALL TIMES.

**5. CONTRACTOR ACCESS**

- CONTRACTOR ACCESS SHALL BE AS NOTED BELOW AND AS SHOWN ON THE SITE PLAN AND CONSTRUCTION ACTIVITY PLAN SHEETS.
- THE CONTRACTOR IS TO ACCESS THE SITE USING THE ENTRANCE SHOWN.
- ALL CONTRACTOR EMPLOYEES WHO ARE DESIGNATED AS DRIVERS FOR THE CONTRACTOR DRIVERS OF TRUCKS CONTAINING MATERIAL DELIVERIES (AGGREGATE, CONCRETE, ETC.) SHALL BE REQUIRED TO SUBMIT THEIR NAME, DRIVER'S LICENSE NUMBER, TRUCK LICENSE PLATE NUMBER AND NAME OF TRUCKING COMPANY TO THE PRIME CONTRACTOR PRIOR TO ENTERING THE JOBSITE.
- THE CONTRACTORS STORAGE AND STAGING AREA WILL BE AS SHOWN IN THE SITE PLAN.
- THE CONTRACTOR SHALL KEEP A RECORD OF THE NAMES OF ALL EMPLOYEES ENTERING THE JOB SITE ON A DAILY BASIS. A RECORD OF EACH SUBCONTRACTOR ENTERING THE JOB SITE SHALL ALSO BE KEPT BY THE CONTRACTOR.
- WHEN THE CONTRACTOR IS NOT WORKING, EQUIPMENT SHALL BE STORED AT THE STAGING AREA.
- THE CONTRACTOR WILL BE PERMITTED TO STORE EQUIPMENT AND MATERIALS ONLY AT THE LOCATIONS SHOWN. PARKED EQUIPMENT AND MATERIAL STOCKPILES SHALL NOT PENETRATE SURFACES DEFINED BY F.A.R. TITLE 14 PART 77 - OBJECTS AFFECTING NAVIGABLE AIRSPACE.
- THE CONTRACTOR SHALL THOROUGHLY CLEAN ALL CONSTRUCTION AREAS AND HAUL ROUTES WHICH WILL BE OPENED TO AIR TRAFFIC TO THE SATISFACTION OF AIRPORT OPERATIONS OR THE RESIDENT ENGINEER. A POWER BROOM AND OPERATOR SHALL BE ON SITE AT ALL TIMES WHEN ACTIVE PAVEMENTS ARE UTILIZED FOR CONSTRUCTION TRAFFIC.
- ALL PAVEMENTS, DRIVES OR ANY OTHER AREAS UTILIZED BY THE CONTRACTOR FOR HAUL ROADS OR STORAGE AREAS SHALL BE MAINTAINED AND REPAIRED TO THE SAME CONDITION OR BETTER THAN THEY WERE PRIOR TO BEGINNING CONSTRUCTION. NO ADDITIONAL COMPENSATION WILL BE MADE TO THE CONTRACTOR FOR THIS WORK.
- ALL VEHICLE AND EQUIPMENT OPERATORS USED BY THE CONTRACTOR SHALL BE PROPERLY TRAINED BY THE CONTRACTOR.
- THE CONTRACTOR SHALL NOTIFY THE AIRPORT IF CONSTRUCTION ACTIVITY WILL REQUIRE THE BLOCKAGE OF EMERGENCY ACCESS TO THE AIRPORT.

**6. WILDLIFE MANAGEMENT**

- THE CONTRACTOR SHALL NOTIFY AIRPORT OPERATIONS OR THE ENGINEER IF ANY WILDLIFE IS SEEN ENTERING THE AIRPORT.
- CONTRACTOR ACCESS GATES SHALL REMAIN CLOSED WHEN THE CONTRACTOR IS NOT WORKING.
- THE CONTRACTOR SHALL DISPOSE OF ALL TRASH INCLUDING FOOD SCRAPS IN APPROVED CONTRACTOR PROVIDED CONTAINERS.

**7. FOREIGN OBJECT DEBRIS (FOD) MANAGEMENT**

- THE CONTRACTOR SHALL PICK UP ANY FOREIGN OBJECT DEBRIS (FOD) SEEN ON THE AIRFIELD PAVEMENTS.
- THE CONTRACTOR SHALL SECURE ALL LOOSE ITEMS FROM VEHICLES PRIOR TO DRIVING ON AIRFIELD PAVEMENTS.

**8. HAZARDOUS MATERIALS (HAZMAT) MANAGEMENT**

- THE CONTRACTOR SHALL DEVELOP A HAZMAT MANAGEMENT PLAN AND KEEP COPIES ON THE JOBSITE OF MATERIAL SAFETY DATA SHEETS (MSDS) FOR ALL MATERIALS HANDLED ON THE JOBSITE.

**9. NOTIFICATION OF CONSTRUCTION ACTIVITIES**

- THE CONTRACTOR SHALL PROVIDE A 24 HOUR EMERGENCY CONTACT PERSON AND PHONE NUMBER.
- THE CONTRACTOR SHALL GIVE A MINIMUM OF 72 HOURS NOTICE TO AIRPORT OPERATIONS PRIOR TO CLOSING ANY PAVEMENTS SO THAT PROPER NOTICE TO AIRMEN (NOTAMS) MAY BE ISSUED BY THE AIRPORT.
- FOR ANY EQUIPMENT USED BY THE CONTRACTOR WITH A HEIGHT GREATER THAN 25', THE CONTRACTOR SHALL PROVIDE TO THE AIRPORT THE TYPE OF EQUIPMENT, TOTAL HEIGHT, AND LOCATION WHERE THE EQUIPMENT WILL BE USED. THE AIRPORT WILL SUBMIT FAA FORM 7460-1 TO THE FAA FOR AN AIRSPACE STUDY. NO EQUIPMENT WITH A HEIGHT GREATER THAN 25' SHALL BE USED UNTIL A DETERMINATION FROM FAA IS RECEIVED.
- IN THE EVENT OF AN EMERGENCY, THE CONTRACTOR SHALL CALL 911.
- CONTACTS FOR THIS PROJECT ARE AS LISTED BELOW.

**AIRPORT OPERATOR**  
BILL NEWBERRY - AIRPORT MANAGER (217) 827-2704

**ENGINEER**  
ANDREW HUEBNER P.E. - PROJECT ENGINEER (217) 787-8050  
CMT - RESIDENT ENGINEER (217) 787-8050

**10. INSPECTION REQUIREMENTS**

- THE CONTRACTOR SHALL INSPECT THE JOBSITE DAILY TO ENSURE COMPLIANCE WITH THE CSPP. THE CHECKLIST FOUND IN APPENDIX 3 OF FAA AC 150/5370-2F MAY BE USED TO AID IN THE INSPECTIONS.
- THE CONTRACTOR SHALL ATTEND AN INSPECTION OF EACH CONSTRUCTION PHASE'S WORK AREA PRIOR TO OPENING THE AREA TO AIRPORT OPERATIONS.

**11. UNDERGROUND UTILITIES**

- IT WILL BE NECESSARY FOR THE CONTRACTOR TO MAKE HIS OWN FIELD INVESTIGATION TO DETERMINE THE EXACT LOCATION OF THE UNDERGROUND UTILITIES AT CRITICAL POINTS. THE LOCATION OF UNDERGROUND UTILITIES AS INDICATED ON THE PLANS HAS BEEN OBTAINED FROM EXISTING RECORDS. NEITHER THE OWNER NOR THE ENGINEER ASSUMES ANY RESPONSIBILITY IN RESPECT TO THE ACCURACY, COMPLETENESS OR SUFFICIENCY OF THE INFORMATION.
- BEFORE INITIATING ANY DIGGING, DRILLING OR EXCAVATING ON THE AIRPORT PROPERTY, THE CONTRACTOR SHALL CALL J.U.L.I.E. AND CONTACT THE LOCAL FAA OFFICE TO ARRANGE FOR UTILITY LOCATES. SEE SECTION 70-17 OF THE SPECIAL PROVISIONS FOR UTILITY CONTACT INFORMATION.

**12. PENALTIES**

- NONCOMPLIANCE BY THE CONTRACTOR WITH AIRPORT RULES AND REGULATIONS OR FAILURE TO COMPLY WITH THE AIRPORT'S APPROVED CSPP AND THE CONTRACTOR'S APPROVED SPCD MAY RESULT IN FINES AS ALLOWED BY LAW.

**13. SPECIAL CONDITIONS**

- ADJACENT CONSTRUCTION MAY IMPACT THE OPERATIONS OF THE CONTRACTOR. SEE THE COORDINATION NOTES FOR ADDITIONAL INFORMATION.

**14. RUNWAY AND TAXIWAY VISUAL AIDS**

- THE CONTRACTOR SHALL USE MARKING, LIGHTING AND SIGNS THAT FOLLOW THE REQUIREMENTS OF FAA AC 150/5370-2F.
- BARRICADES SHALL BE PLACED AT THE LOCATIONS SHOWN ON THE CONSTRUCTION ACTIVITY PLAN SHEET.

**15. MARKING AND SIGNS FOR ACCESS ROUTES**

- BARRICADES AND SIGNS SHALL BE USED ALONG THE CONTRACTOR'S ACCESS ROUTE AS DETAILED ON THIS SHEET AND THE CONSTRUCTION ACTIVITY PLAN SHEET.

**16. HAZARD MARKING AND LIGHTING**

- THE CONTRACTOR SHALL FURNISH, ERECT, AND MAINTAIN MARKINGS AND ASSOCIATED LIGHTING OF OPEN TRENCHES, EXCAVATIONS, TEMPORARY STOCKPILES, AND HIS/HER CONSTRUCTION EQUIPMENT.
- ALL CONSTRUCTION EQUIPMENT SHALL BE FLAGGED AND/OR LIGHTED IN ACCORDANCE WITH FAA ADVISORY CIRCULAR 150/5370-2F AND 150/5210-5C AT ALL TIMES WHILE OPERATING ON AIRPORT PROPERTY. THE MAXIMUM EQUIPMENT HEIGHT IS 25'.
- BARRICADES SHALL BE PLACED AT THE LOCATIONS SHOWN ON THE CONSTRUCTION ACTIVITY PLAN SHEET OR AS DIRECTED BY THE RESIDENT ENGINEER.
- THE CONTRACTOR SHALL INSPECT THE BARRICADES ONCE DURING EACH WORK DAY TO INSURE PROPER PLACEMENT AND PROPER OPERATION OF THE RED LIGHTS AND FLAG PLACEMENT.

**17. PROTECTION**

- ALL WORK REQUIRED ON AN ACTIVE TAXIWAY OR INSIDE OF AN ACTIVE TAXIWAY OBJECT FREE AREA, WHICH EXTENDS 65.5' FROM THE TAXIWAY CENTERLINE, WILL REQUIRE THE TAXIWAY TO BE CLOSED. THE CONTRACTOR SHALL COORDINATE WITH THE AIRPORT A MINIMUM OF 72 HOURS PRIOR TO THE REQUESTED CLOSURE TIME.

**18. OTHER LIMITATIONS ON CONSTRUCTION**

- IF, DURING CONSTRUCTION, AN EMERGENCY IS DECLARED BY THE AIRPORT, THE CONTRACTOR SHALL IMMEDIATELY CLEAR THE PAVEMENT OF ALL VEHICLES, PERSONNEL AND EQUIPMENT.
- BROKEN CONCRETE, BROKEN ASPHALT, AND OTHER MISCELLANEOUS DEBRIS SHALL BE DISPOSED OF OFF AIRPORT PROPERTY, UNLESS OTHERWISE SPECIFIED.

FILE: TAZ-4342-GC005.dwg  
UPDATE BY: Andrew Huebner  
PLOT DATE: 5/1/2014 9:37 AM

**TA006**

REVISIONS

NUMBER	BY	DATE

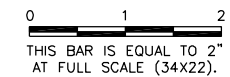

**TAYLORVILLE MUNICIPAL AIRPORT**  
**TAYLORVILLE, ILLINOIS**  
**REHABILITATE NORTH PORTION OF AIRCRAFT PARKING APRON**  
**CONSTRUCTION SAFETY PHASING**  
**PLAN NOTES**

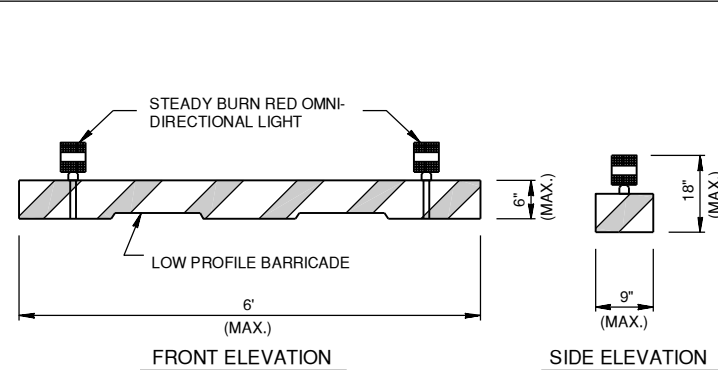

**BEAM BARRICADE DETAILS**  
N.T.S.

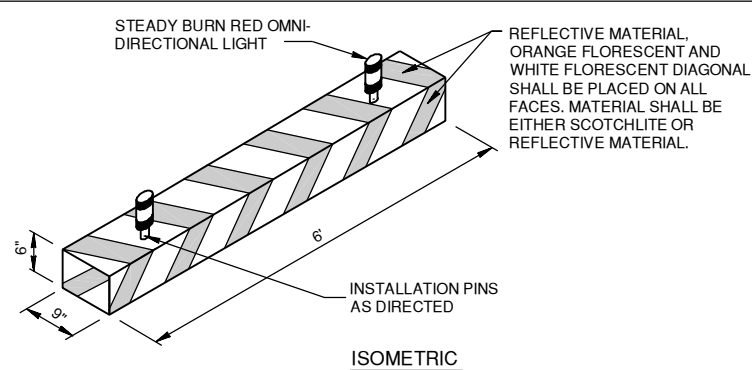

- NOTES**
- BARRICADE SHALL BE WEIGHTED TO WITHSTAND DISPLACEMENT BY JET OR PROP BLAST.
  - BARRICADE SHALL BE EASILY COLLAPSIBLE UPON CONTACT WITH AIRCRAFT.
  - PLACE AT 10' INTERVALS.
  - NO SEPARATE PAYMENT WILL BE MADE FOR THIS ITEM. COSTS SHALL BE CONSIDERED INCIDENTAL TO THE PROJECT.

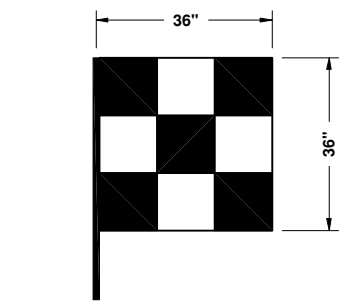

**TRUCK SIGNAL FLAG**  
ORANGE / WHITE  
N.T.S.

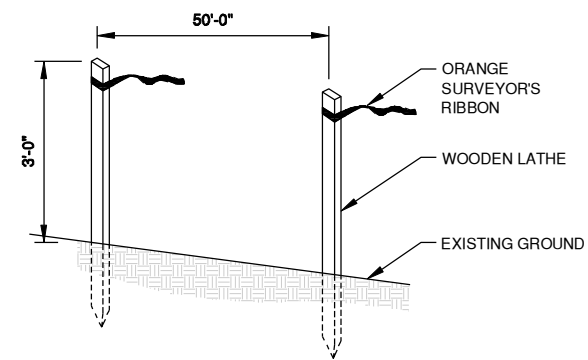

**CONSTRUCTION SETBACK LINE DETAIL**  
N.T.S.

© Copyright, CMT, Inc.

**CMT**  
GRAHAM, MURPHY & TULLY, INC.  
CONSULTING ENGINEERS  
License No. 184-000618

DESIGN BY:	AJH
DRAWN BY:	CMT
CHECKED BY:	CBG
APPROVED BY:	CET
DATE:	APRIL 18, 2014
JOB No:	13050-01
IL PROJ. NO.	TAZ-4342
SBG NO.	3-17-SBGP-XX
SHEET	04 OF 14 SHEETS

K:\Taylorville\1305001\Draw\Sheets