

SPECIFICATIONS FOR STANDARD ALUMINUM GRATING
 Main Bearing Bars (MBB) shall be 3/16" x 1 1/2" on 1 3/16" centers and conform to ASTM B211 Alloy 6061-T6.
 Cross bars (CB) shall be 3/16" x 1 1/2" on 4" centers and conform to ASTM B221 Alloy 6063-T5 or 6061-T6.

OR
 Aluminum Grating with modified "T" sections for main bearing bars shall meet the following requirements:
 Main bars shall conform to ASTM B221 Alloy 6061-T6 and have a minimum section modulus equal to 0.0705 in.³ per bar, a depth of 1 1/2", spaced on 1 3/16" centers.
 Cross bars shall conform to ASTM B221 Alloy 6063-T5 or T-42 and spaced on 4" centers.

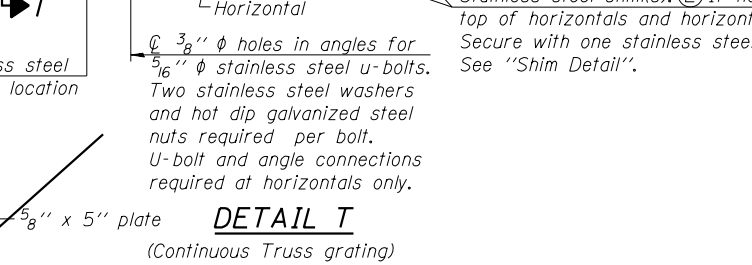
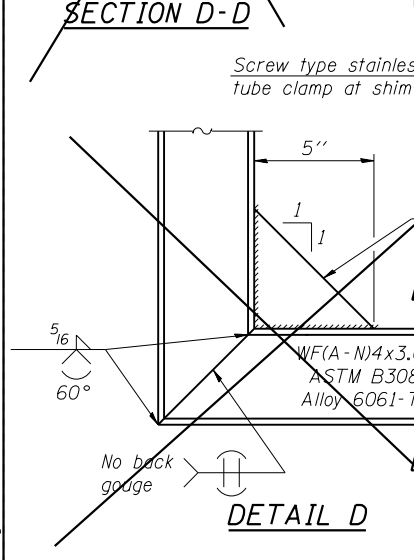
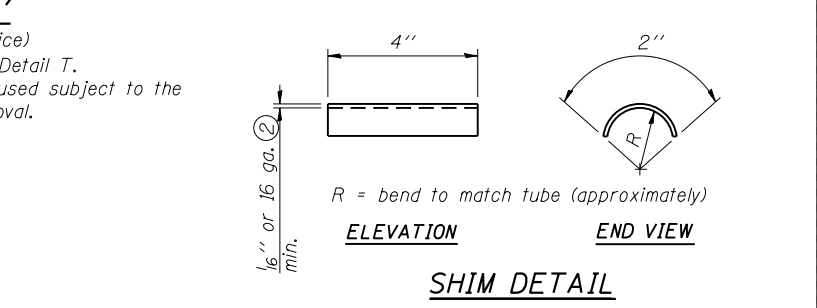
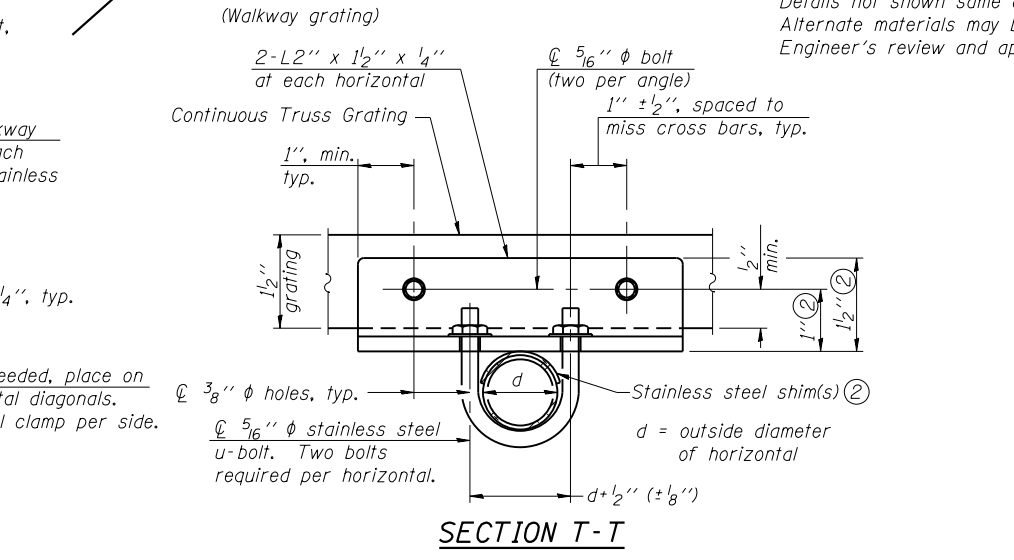
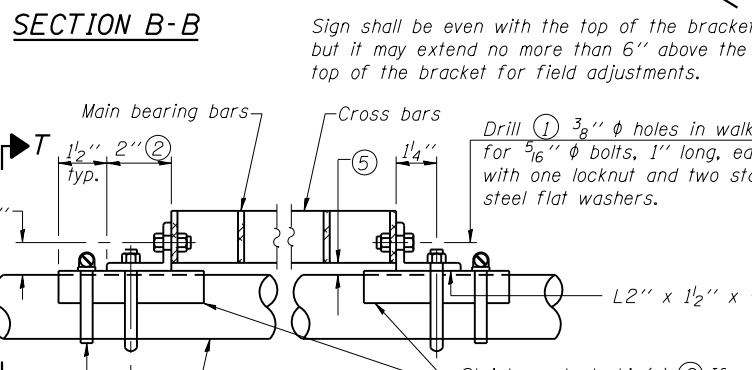
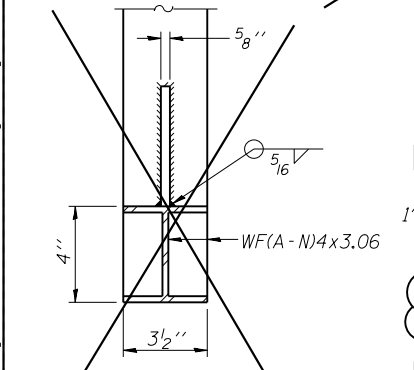
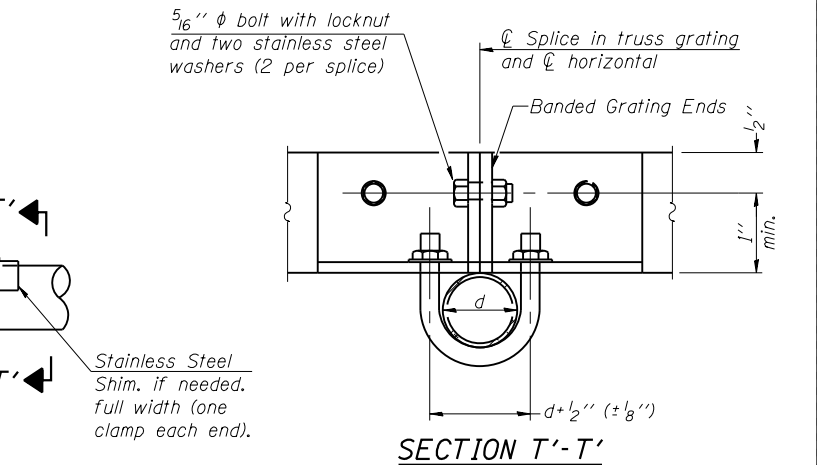

Structure Number	Station	A	⑥ B	C	⑥ D
IC0161094L050.4-000	119+31.57	0'-5 3/8"	2'-9"	4'-6"	7'-9"

- Drilling holes in grating may be done in shop or field, based on Contractor's preference and subject to accurate alignment.
- Stainless steel shims shall be placed as shown in Detail T if needed to compensate for alignment variations between horizontal and diagonal pipes beyond adjustment provided by angles. Thicker shims may be used subject to shims performing properly.
- If Handrail Joint present, weld angle to WF(A-N)4 and 1/4" extension bars. (See Base Sheet OSC-A-8.)
- 1/8" x 1/2" x 2" welded to handrail posts to protect locations that contact grating.
- Tube to grating gap may vary from 0 to 1/2", max. to align walkway, allow for camber, etc.
- Based on actual sign height, D_s, given on OSC-A-1.