

TYPICAL CROSS SECTION - STAGE I
(Looking West)

* Existing Conduits presumed to be empty and shall be removed. Contractor to verify prior to removal by opening these ducts first to confirm. If the ducts are not empty, they shall be protected, temporarily supported and/or relocated and mounted to the new structures. This work shall be included in the pay item for Removal of Existing Structures, Special.

** Closure pour to be completed following Stage III deck pour to account for differential deflections of Stage I and Stage III structures.

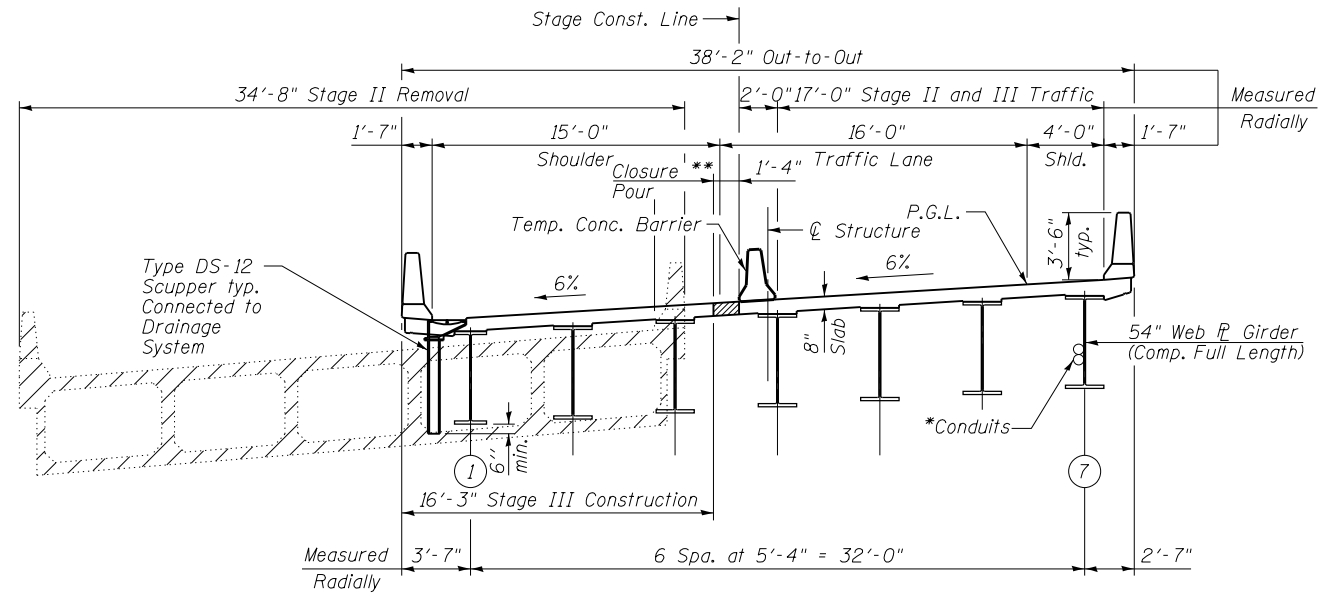

TYPICAL CROSS SECTION - STAGE II and III
(Looking West)

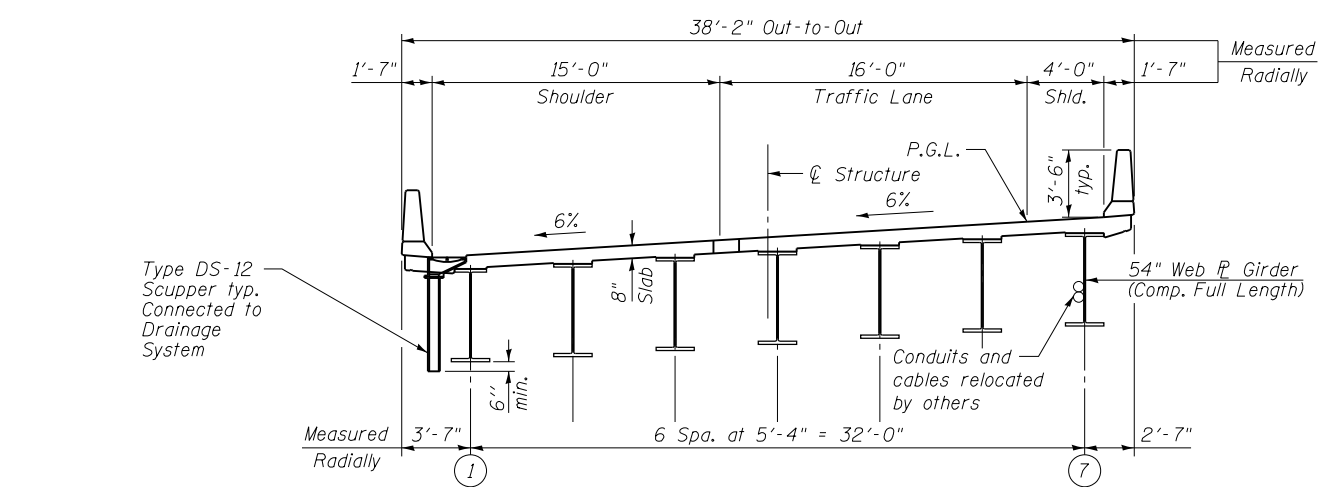

TYPICAL CROSS SECTION - FINAL
(Looking West)

Notes:
See sheet S19 of S49 for Drainage System Details.
Stage construction line of individual substructure units vary with respect to deck and approach stage construction line.
See sheets S5 and S6 of S49 for proposed demolition plan of existing structure.
Refer to Roadway Plans for quantity of Temporary Concrete Barriers.

USER NAME =	DESIGNED - MAH	REVISED
CHECKED - LDB	REVISOR	
PLOT SCALE =	DRAWN - DR	REVISED
PLOT DATE =	CHECKED - JMH	REVISED

F.A.P. RTE.	SECTION	COUNTY	TOTAL SHEETS	SHEET NO.
0383	0303-474HB-R	COOK	368	196
CONTRACT NO. 60F63				
ILLINOIS FED. AID PROJECT				