

PLAN - TOP FLANGE

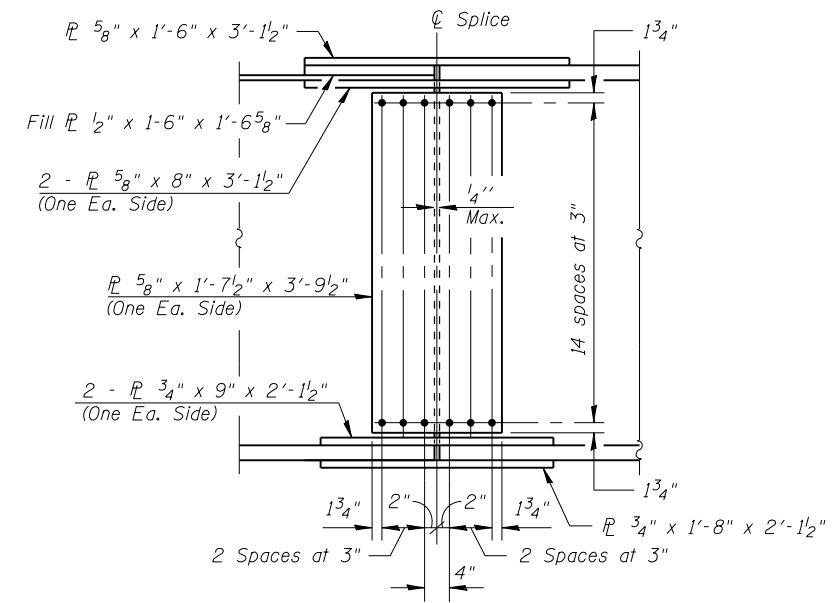

ELEVATION

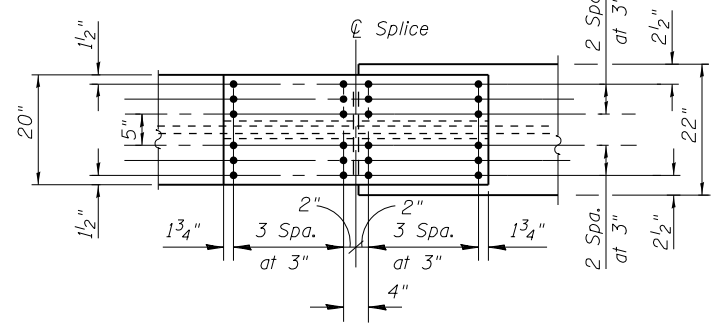

PLAN - BOTTOM FLANGE

FIELD SPLICE 1 DETAIL

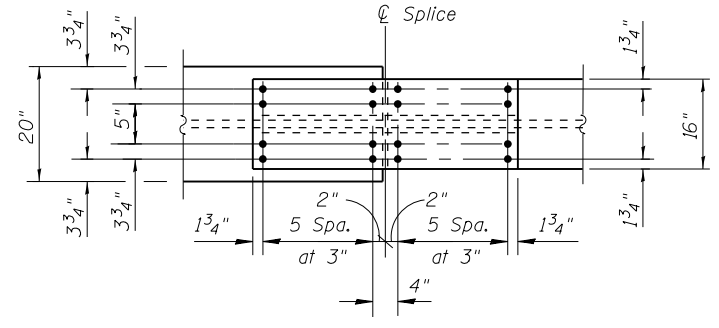

PLAN - TOP FLANGE

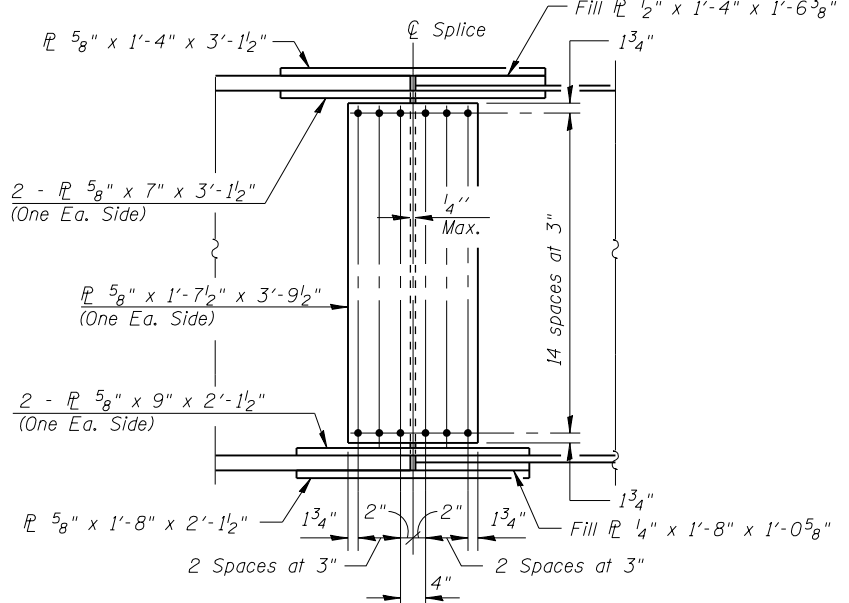

ELEVATION

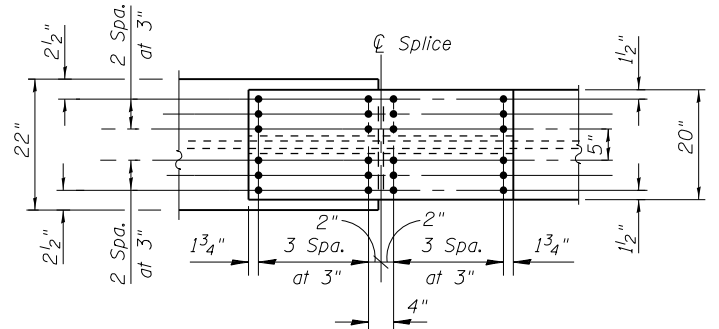

PLAN - BOTTOM FLANGE

FIELD SPLICE 2 DETAIL

Notes:
 All splice plates shall comply with NTR.
 All structural steel, except fill plates shall be AASHTO M270, Grade 50.

(Sheet 2 of 3)



USER NAME =	DESIGNED - MAH	REVISED
	CHECKED - LDB	REVISED
PLOT SCALE =	DRAWN - DR	REVISED
PLOT DATE =	CHECKED - JMH	REVISED

STATE OF ILLINOIS
 DEPARTMENT OF TRANSPORTATION

STEEL DETAILS
 STRUCTURE NO. 016-1322

SHEET NO. S27 OF S49 SHEETS

F.A.P. RTE.	SECTION	COUNTY	TOTAL SHEETS	SHEET NO.
0383	0303-474HB-R	COOK	368	219
CONTRACT NO. 60F63				

ILLINOIS FED. AID PROJECT