

TRUSS UNIT TABLE

Structure Number	Station	Design Truss Type	Exterior Units (2)			Interior Unit			Upper & Lower Chord		Verticals; Horizontals; Vertical, Horizontal, and Interior Diagonals		Camber at Midspan	Splicing Flange						
			No. Panels per Unit	Unit Lgth.(L _e)	Panel Lgth.(P)	No. Req'd.	No. Panels per Unit	Unit Lgth.(L _i)	Panel Lgth.(P)	O.D.	Wall	O.D.		Wall	Bolts		Weld Sizes		A	B
															No./Splice	Dia.	W	W ₁		
IS022S059L1	810+00	II-A	5	28'-11 1/2"	5'-5"	1	6	33'-9"	5'-5"	5 1/2"	5/16"	3"	5/16"	2 1/2"	6	7/8"	3/8"	1/4"	9 1/4"	12 1/4"
IS022S059R2	914+05	II-A	6	34'-1 1/2"	5'-4 1/2"	1	6	33'-6"	5'-4 1/2"	6"	5/16"	3"	5/16"	3"	6	7/8"	3/8"	1/4"	10 1/4"	13 3/4"
IS022S059L3	827+43	II-A	6	34'-1 1/2"	5'-4 1/2"	1	6	33'-6"	5'-4 1/2"	6"	5/16"	3"	5/16"	3"	6	7/8"	3/8"	1/4"	10 1/4"	13 3/4"

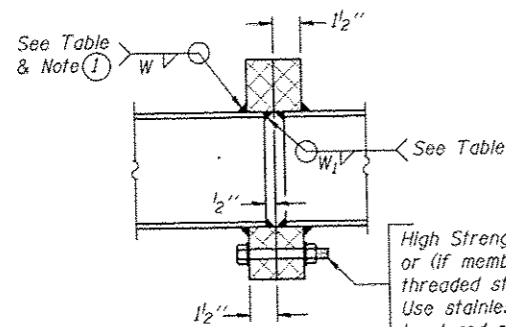

SECTION B-B

High Strength bolts with locknuts or (if members interfere) threaded studs with 2 locknuts. Use stainless steel washers under head and nut. See table.

① Splicing Flanges shall be attached to each truss unit with the truss shop assembled to camber shown. Truss units shall be in proper alignment and flange surfaces shall be shop bolted into full contact before welding. Sufficient external welds or tacks shall be made to secure flanges until remaining welds are made after disassembly. Adjacent flanges shall be "match marked" to insure proper field assembly.

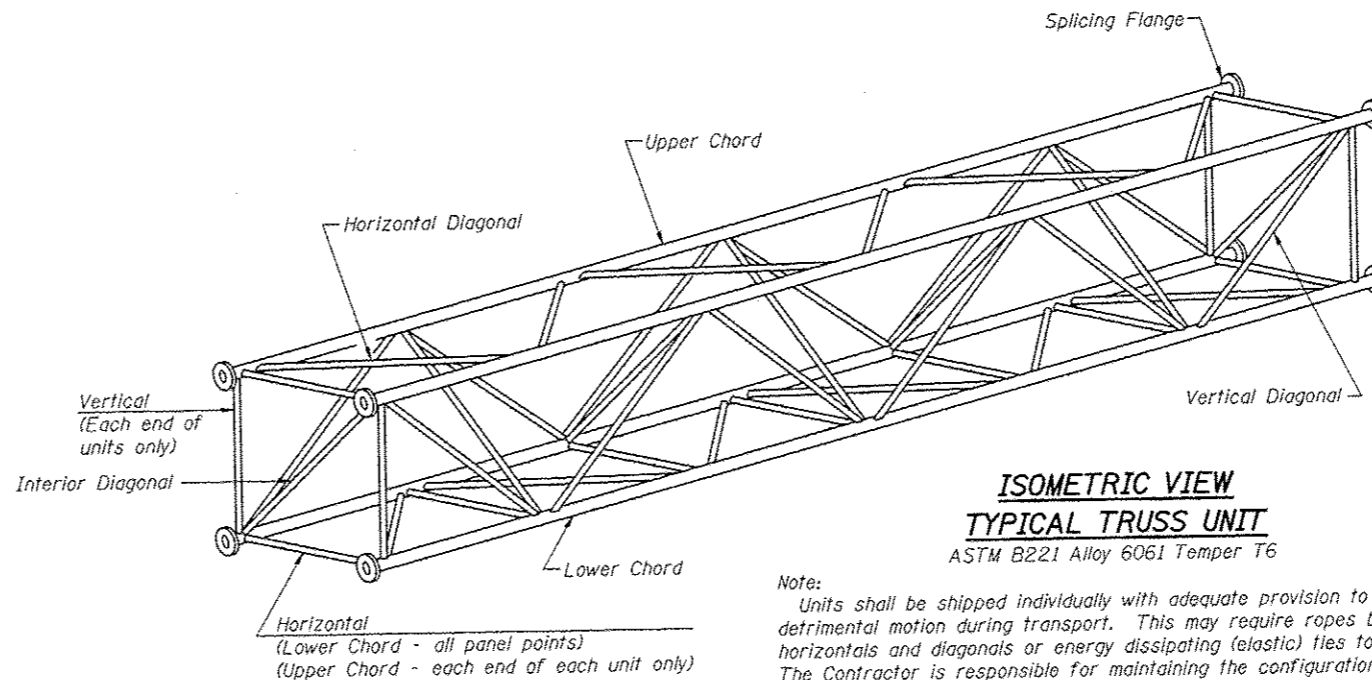

ISOMETRIC VIEW TYPICAL TRUSS UNIT
ASTM B221 Alloy 6061 Temper T6

Note: Units shall be shipped individually with adequate provision to prevent detrimental motion during transport. This may require ropes between horizontals and diagonals or energy dissipating (elastic) ties to the vehicle. The Contractor is responsible for maintaining the configuration and protection of the units.

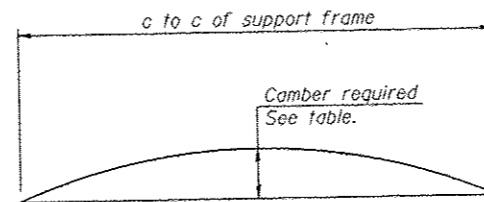

CAMBER DIAGRAM

Camber curve shown is theoretical. Actual camber attained by slope changes at splices between units.

CAMBER ATTAINMENT EXAMPLES:

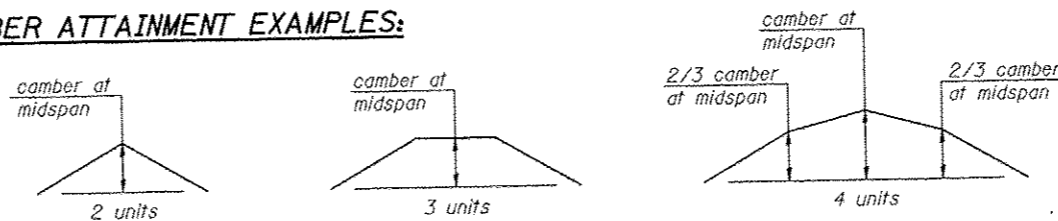

Camber shown is for fabrication only, measured with truss fully supported. (No-load condition)

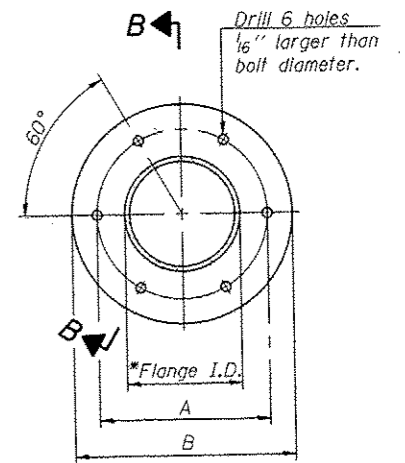

TRUSS TYPES I-A, II-A, & III-A

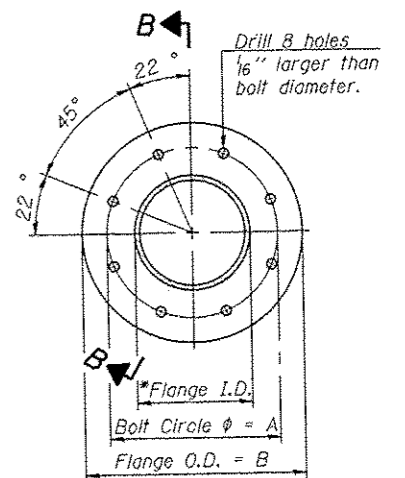

TRUSS TYPES II-A & III-A

SPLICING FLANGES

ASTM B221, Alloy 6061-T6 or ASTM B209, Alloy 6061-T651
*To fit O.D. of Chord with maximum gap of 1/16"

OS4-A-2

6-1-12

FILE NAME	USER NAME	DESIGNED	REVISED
#FILES		DRAWN	REVISED
		CHECKED	REVISED
		DATE	REVISED

STATE OF ILLINOIS DEPARTMENT OF TRANSPORTATION

OVERHEAD SIGN STRUCTURES - ALUMINUM TRUSS DETAILS FOR TRUSS TYPES I-A, II-A AND III-A

SCALE: SHEET NO. 6 OF 15 SHEETS STA. TO STA.

F.A.P. RTE.	SECTION	COUNTY	TOTAL SHEETS	SHEET NO.
338	(112 & 113) WRS-5	DUPAGE	963	406
				CONTRACT NO. 60131
ILLINOISIFIED, AID PROJECT				