

INSIDE ELEVATION - FORM LINER

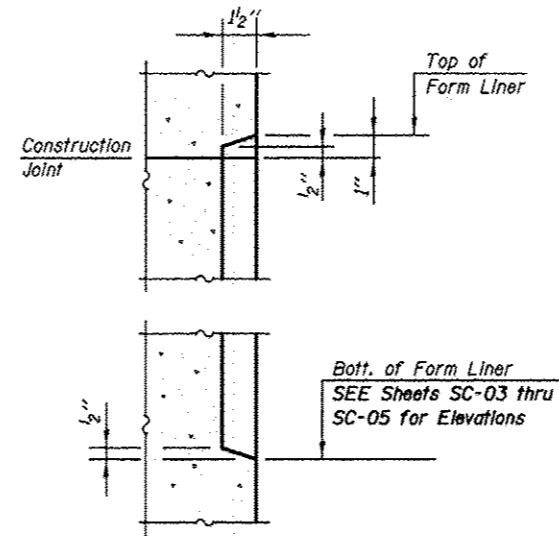

SECTION A-A

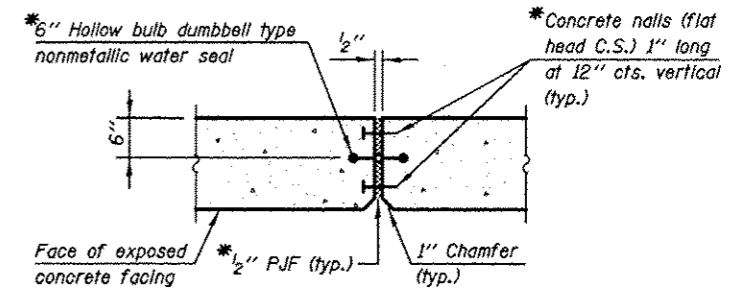

WALL EXPANSION JOINT DETAIL

* Cost Included with "Concrete Structures".

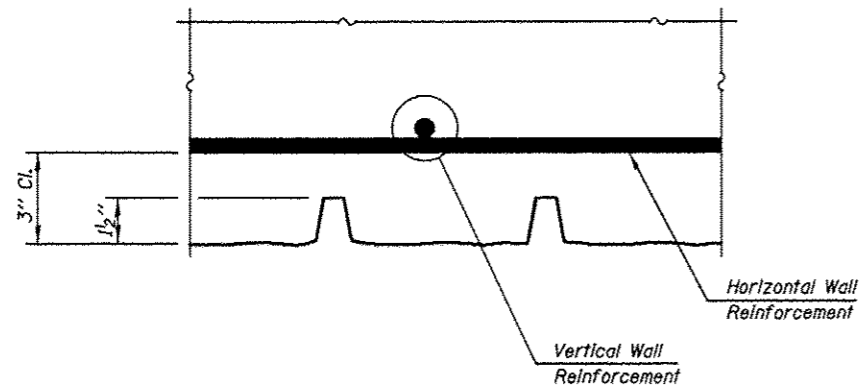

PLAN - FORM LINER

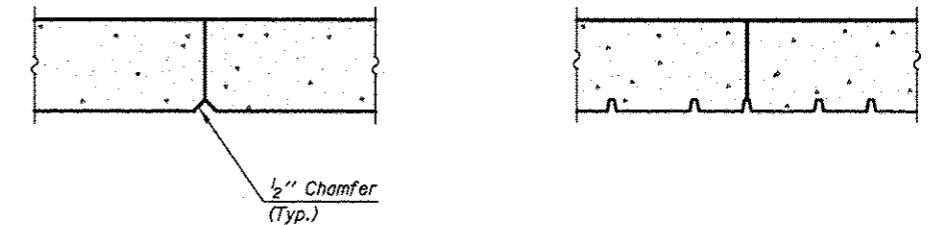

WALL CONSTRUCTION JOINT DETAIL

NOTE:
SEE Sheets SC-03 thru SC-05
for Bottom of Form Liner Elevations

| WALL # | |
|----------|-----------|
| STATION | ELEVATION |
| 00+00.00 | El. 00.00 |
| | |
| | |
| | |
| | |
| | |
| | |
| | |

| WALL # | |
|----------|-----------|
| STATION | ELEVATION |
| 00+00.00 | El. 00.00 |
| | |
| | |
| | |
| | |
| | |
| | |
| | |

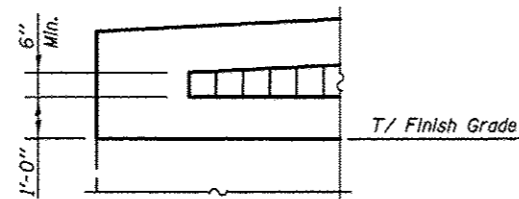

END FORM LINER DETAIL