

* WHEN AN EXPANSION JOINT EXISTS BELOW THE CONNECTOR, BOLTS SHALL BE PROVIDED WITH A LOCKNUT OR DOUBLE NUTS AND SHALL BE TIGHTENED ONLY TO A POINT THAT WILL ALLOW PLATE G TO BE FREE TO MOVE.

NOTES:

1. INSTALL PLATE WASHER D SO THE 1" PROJECTION FILLS THE REMAINDER OF THE SLOTTED HOLES IN THE 1" END PLATE ON PLATE G AFTER THE 1" DIA BOLTS ARE IN PLACE.
2. SEE STANDARD C1 FOR DETAILS OF GUARDRAIL NOT SHOWN.
3. THE TYPE T5 TERMINAL IS TYPICALLY UTILIZED TO CONNECT GALVANIZED STEEL PLATE BEAM GUARDRAIL TO THE CONCRETE BRIDGE PARAPET AT THE DEPARTING END OF A NEW BRIDGE.
4. UNDER NO CIRCUMSTANCES SHALL AN EXISTING TERMINAL, THAT WAS DESIGNED USING A PREVIOUS STANDARD, BE ATTACHED TO OR MODIFIED IN ANYWAY FROM ITS ORIGINAL DESIGN. IF ANY MODIFICATION IS REQUIRED AND A PROPER BARRIER WARRANT HAS BEEN COMPLETED, THE ENTIRE BARRIER INSTALLATION SHALL BE COMPLETELY REMOVED AND REPLACED WITH A NEW SYSTEM THAT CONFORMS TO THE CURRENT STANDARD.
5. TRAFFIC BARRIER TERMINAL SHALL BE IN ACCORDANCE WITH THE MANUFACTURER'S DETAILS AND SPECIFICATIONS.
6. 1" DIA. ANCHOR BOLT, 3'-6" LENGTH, SHALL BE CAST IN PLACE AN EMBEDDED LENGTH 3'-2" IN THE CONCRETE PARAPET. DRILLING FOR PLACEMENT OF THIS ANCHORAGE IS NOT PERMITTED.
7. TERMINAL POSTS SHALL NOT BE INSTALLED IN CONCRETE OR HMA PAVEMENT. WHEN NECESSARY, USE LEAVE-OUT DETAIL PER STANDARD C1.
8. REFERENCE STANDARD B2 FOR GUTTER TRANSITION AT TRAFFIC BARRIER TERMINAL TYPE T5.
9. TERMINAL BARRIER CLEARANCE DISTANCE SHALL CONFORM WITH TABLE 2 ON STANDARD C1.

TYPE T5 - CONCRETE BRIDGE PARAPET

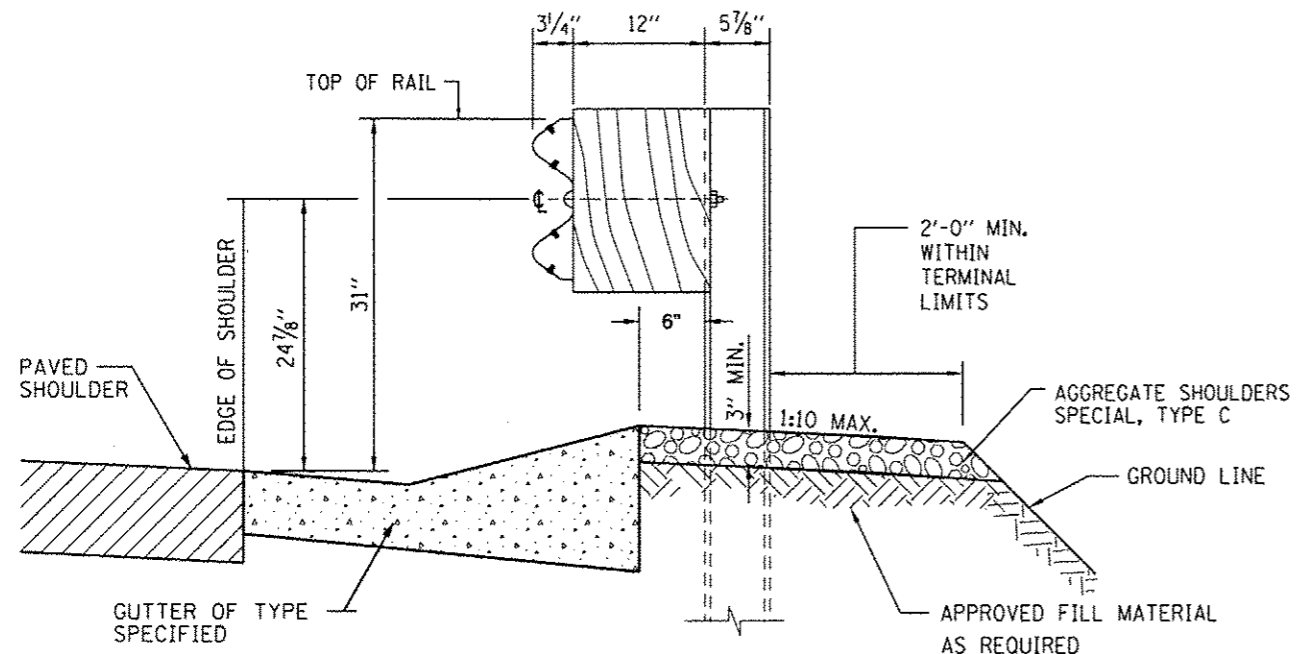

SECTION WITH GUTTER

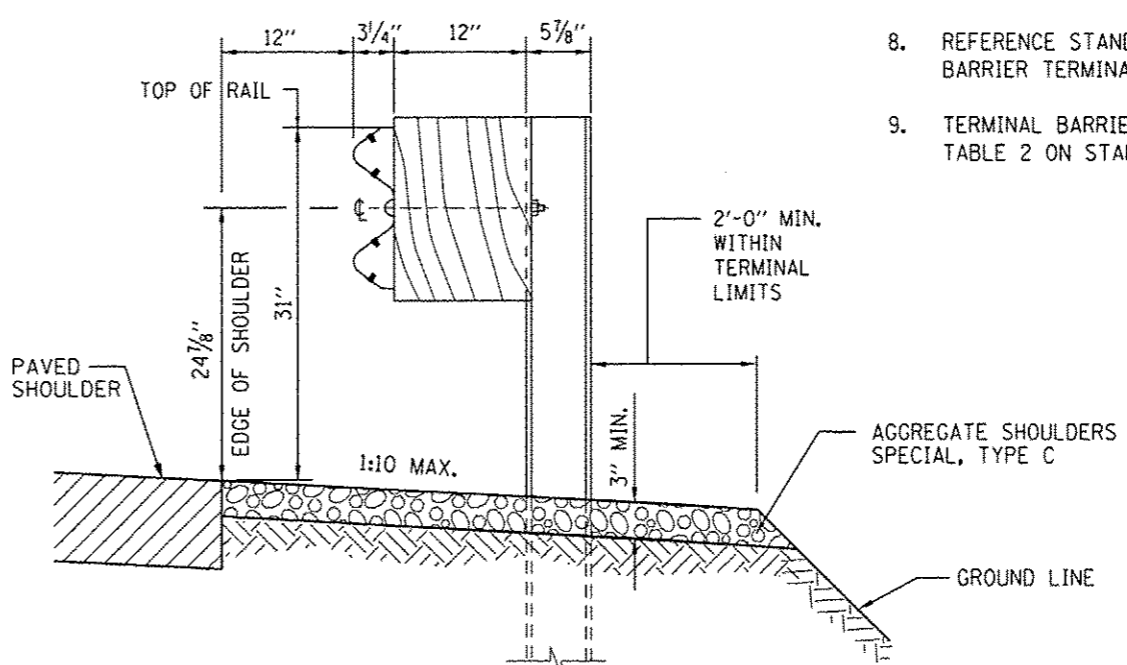

SECTION WITHOUT GUTTER

SECTION A-A

CONTRACT 60I31 SHEET 913 OF 963
SHEET 1 OF 2

APPROVED *Paul Kovacs* DATE 7-1-2009
CHIEF ENGINEER

REVISIONS	
3-1-2010	ADDED SECTION A-A, ADDED NOTES
1-1-2011	REVISED NOTES
2-7-2012	REVISED NOTES

Illinois Tollway
Open Roads for a Faster Future

TRAFFIC BARRIER
TERMINAL, TYPE T5

STANDARD C8-03