

ELEVATION

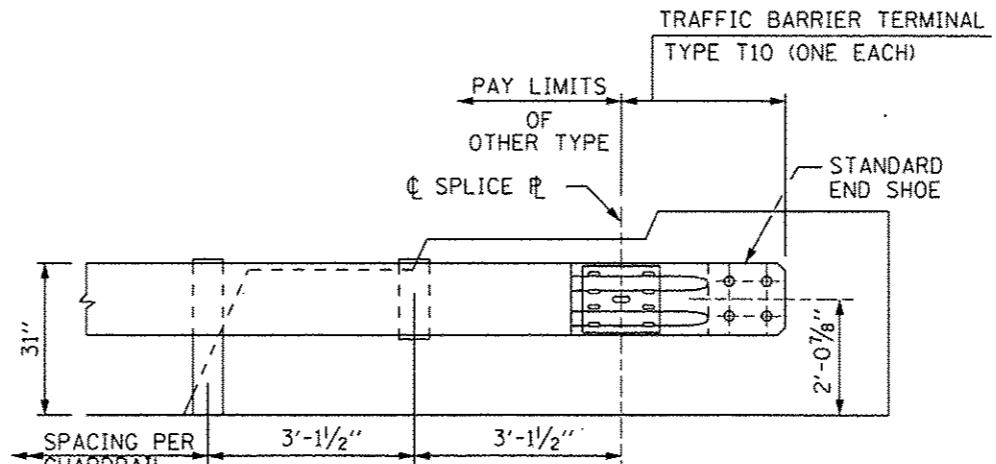

ELEVATION

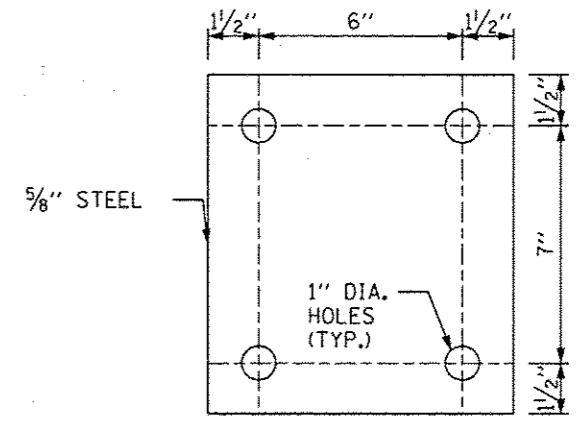

PARAPET STEEL BEARING PLATE DETAIL

(4 EACH INDIVIDUAL 5"x5"x5/8" STEEL PLATES WITH CENTERED HOLES MAY BE SUBSTITUTED FOR THE PLATE SHOWN)

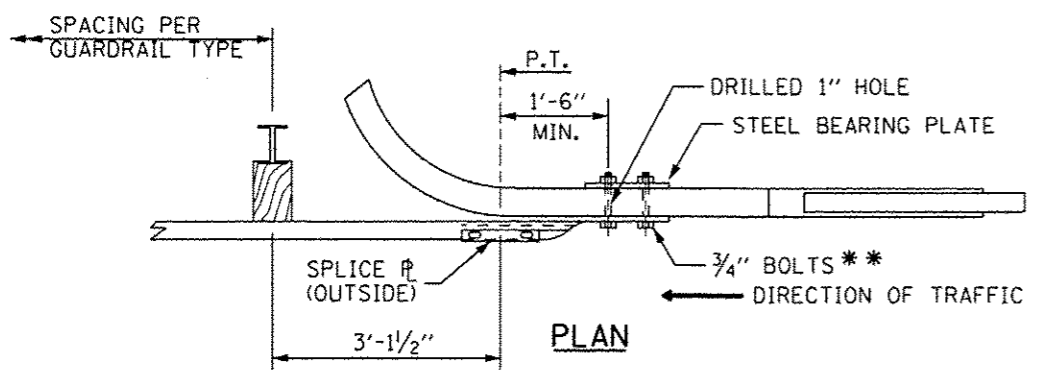

CURVED WING

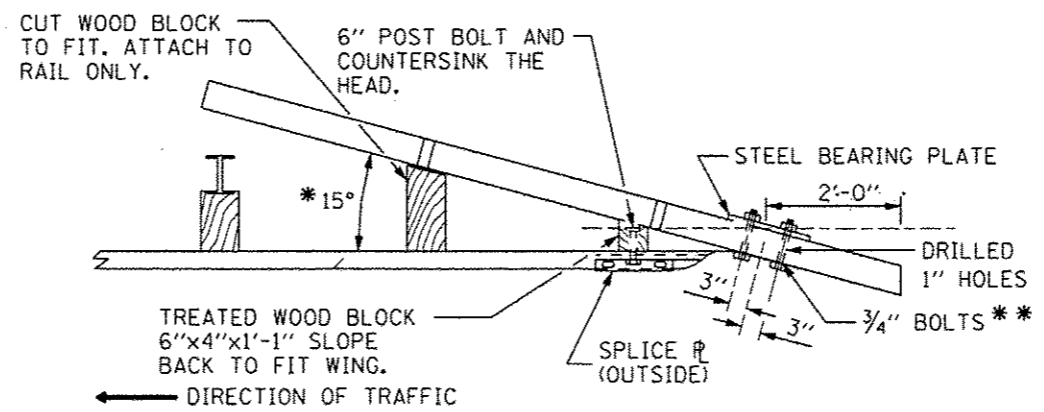

PLAN FLARED WING

NOTES:

1. SEE STANDARD C1 FOR DETAILS OF GUARDRAIL NOT SHOWN.
2. THE TYPE T10 TERMINAL IS TYPICALLY UTILIZED TO CONNECT GALVANIZED STEEL PLATE BEAM GUARDRAIL TO THE DEPARTING END OF AN EXISTING BRIDGE CONCRETE WING WALL OR PARAPET.
3. UNDER NO CIRCUMSTANCES SHALL AN EXISTING TERMINAL, THAT WAS DESIGNED USING A PREVIOUS STANDARD, BE ATTACHED TO OR MODIFIED IN ANYWAY FROM ITS ORIGINAL DESIGN. IF ANY MODIFICATION IS REQUIRED AND A PROPER BARRIER WARRANT HAS BEEN COMPLETED, THE ENTIRE BARRIER INSTALLATION SHALL BE COMPLETELY REMOVED AND REPLACED WITH A NEW SYSTEM THAT CONFORMS TO THE CURRENT STANDARD.
4. TRAFFIC BARRIER TERMINAL SHALL BE IN ACCORDANCE WITH THE MANUFACTURER'S DETAILS AND SPECIFICATIONS.
5. WHEN END SHOE IS ATTACHED TO A BRIDGE PARAPET WHICH HAS AN EXPANSION JOINT, THE BOLTS SHALL BE PROVIDED WITH A LOCKNUT OR DOUBLE NUT AND SHALL BE TIGHTENED ONLY TO A POINT THAT WILL ALLOW GUARDRAIL MOVEMENT.
6. THE ANCHOR CONE SHALL BE SET FLUSH WITH THE SURFACE OF THE CONCRETE.
7. EXTERNALLY THREADED STUDS PROTRUDING FROM THE SURFACE OF THE CONCRETE WILL NOT BE PERMITTED.

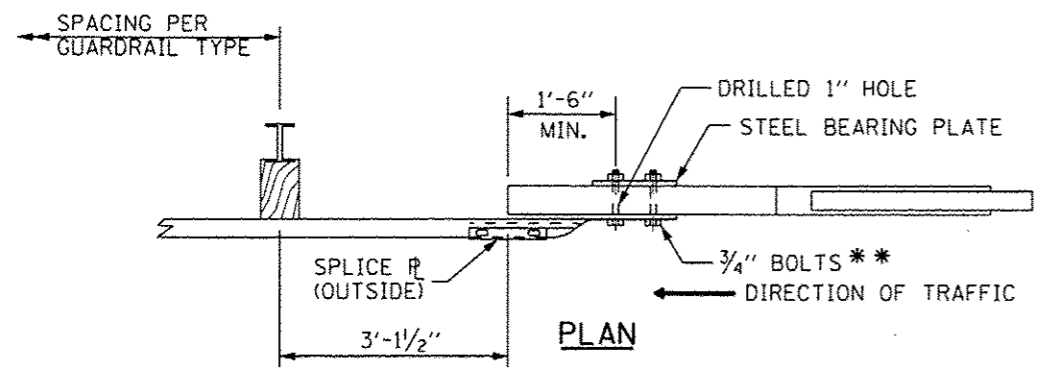

TANGENT WING

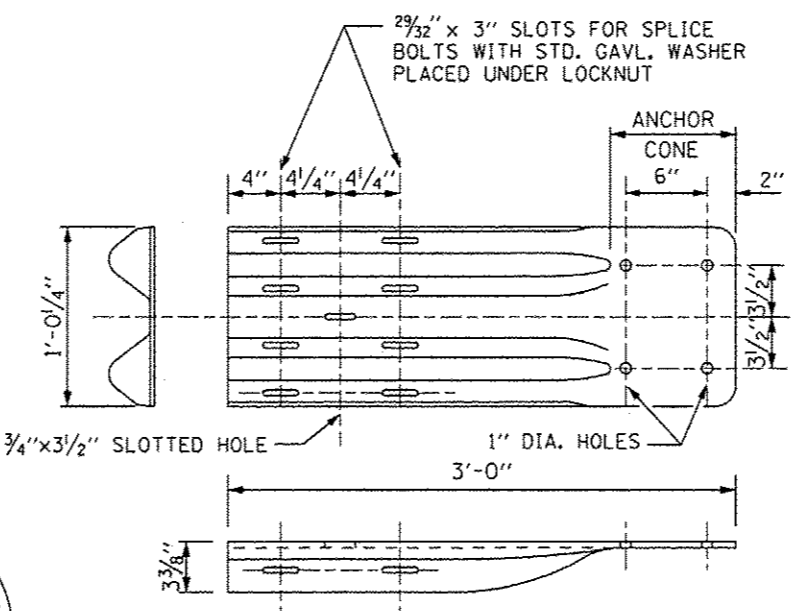

END SHOE

GENERAL NOTE:

- \* OR TO BE DETERMINED IN THE FIELD.
- \*\* HEAD OF BOLT TO BE ON TRAFFIC SIDE. SEE DETAIL "A"

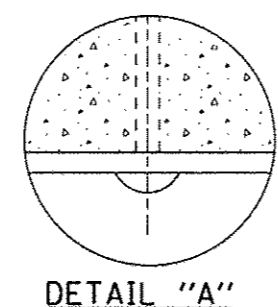

DETAIL "A"

CONTRACT 60I31 SHEET 921 OF 963



DATE	REVISIONS
3-1-2010	REVISED NOTES, ADDED END SHOE AND PARAPET BEARING PLATE DETAIL.
1-1-2011	REVISED END SHOE HEIGHT ATTACHMENT.
2-7-2012	REVISED BOLT NOTE, ADDED DETAIL "A" AND REVISED NOTES.

TRAFFIC BARRIER TERMINAL, TYPE T10

STANDARD C11-03

APPROVER *Paul Kovacs* DATE 7-1-2009  
CHIEF ENGINEER