

OPTION 1

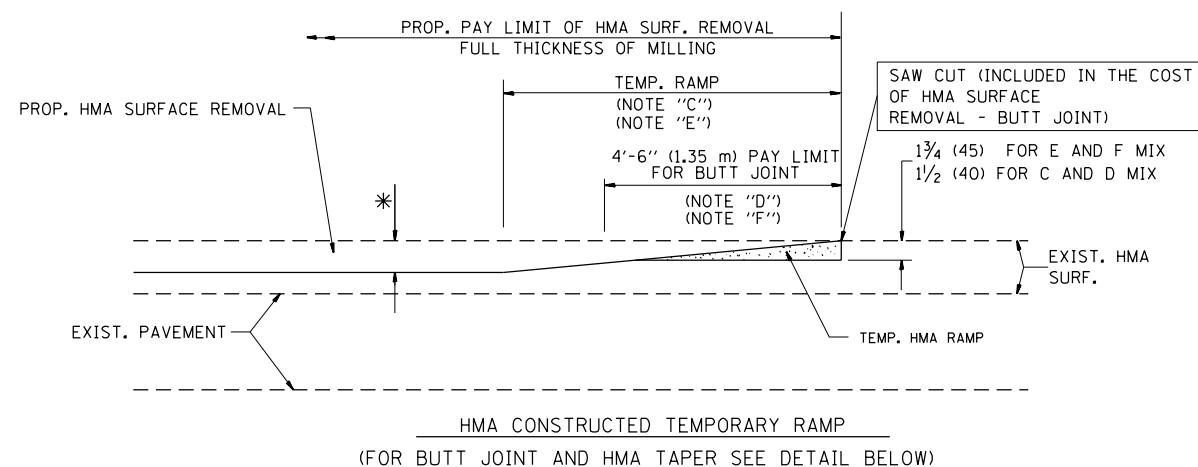

OPTION 2

TYPICAL TEMPORARY RAMP

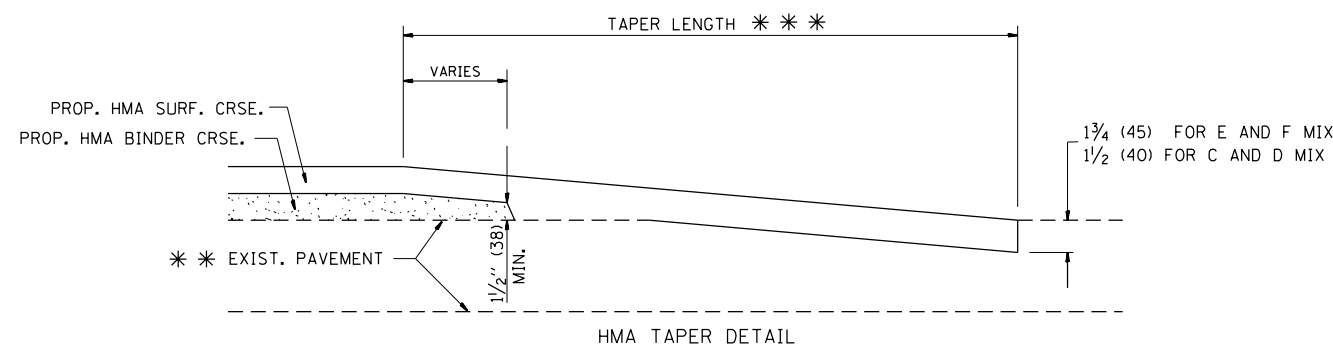
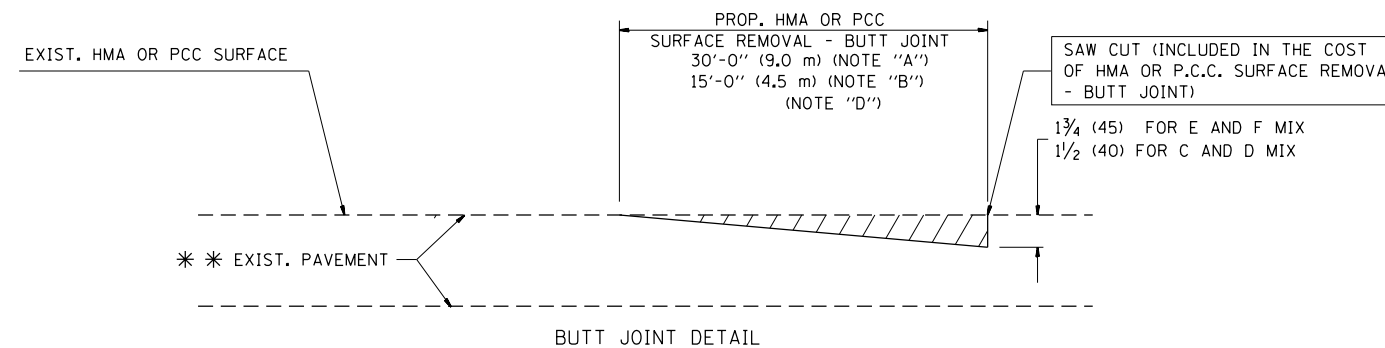

TYPICAL BUTT JOINT AND HMA TAPER FOR RESURFACING ONLY

* * PC CONCRETE, HMA OR HMA RESURFACED PAVEMENT.

NOTES

- A: MAINLINE ROADWAYS AND MAJOR SIDE ROADS.
 - B: MINOR SIDE ROADS.
 - C: THE TEMP. RAMP SHALL BE CONSTRUCTED IMMEDIATELY UPON REMOVAL OF THE EXISTING HMA SURFACE.
 - D: THE BUTT JOINT SHALL BE CONSTRUCTED IMMEDIATELY PRIOR TO PLACING THE PROPOSED HMA COURSES.
 - E: TAPER THE TEMP. RAMP AT A RATE OF 3'-0" (900 mm) PER 1 INCH (25 mm) OF MILLING THICKNESS.
 - F: INSTALLATION AND REMOVAL OF THE 4'-6" (1.35 m) TEMP. RAMP IS INCLUDED IN COST OF HMA SURFACE REMOVAL - BUTT JOINT
 - G: SEE ARTICLE 406.08 AND 406.14 OF THE STANDARD SPECIFICATIONS FOR "HMA AND/OR PCC SURFACE REMOVAL, BUTT JOINT".
- * SEE TYPICAL SECTIONS FOR MILLING THICKNESS.
- * * * 20'-0" (6.1 m) PER 1 (25) RESURFACING (NOTE "A")
10'-0" (3.0 m) PER 1 (25) RESURFACING (NOTE "B")

BASIS OF PAYMENT:

THE BUTT JOINT WILL BE PAID FOR AT THE CONTRACT UNIT PRICE PER SQUARE YARD (SQUARE METER) FOR "HOT-MIX ASPHALT SURFACE REMOVAL - BUTT JOINT" OR FOR "PORTLAND CEMENT CONCRETE SURFACE REMOVAL - BUTT JOINT".

ALL DIMENSIONS ARE IN INCHES (MILLIMETERS) UNLESS OTHERWISE SHOWN.

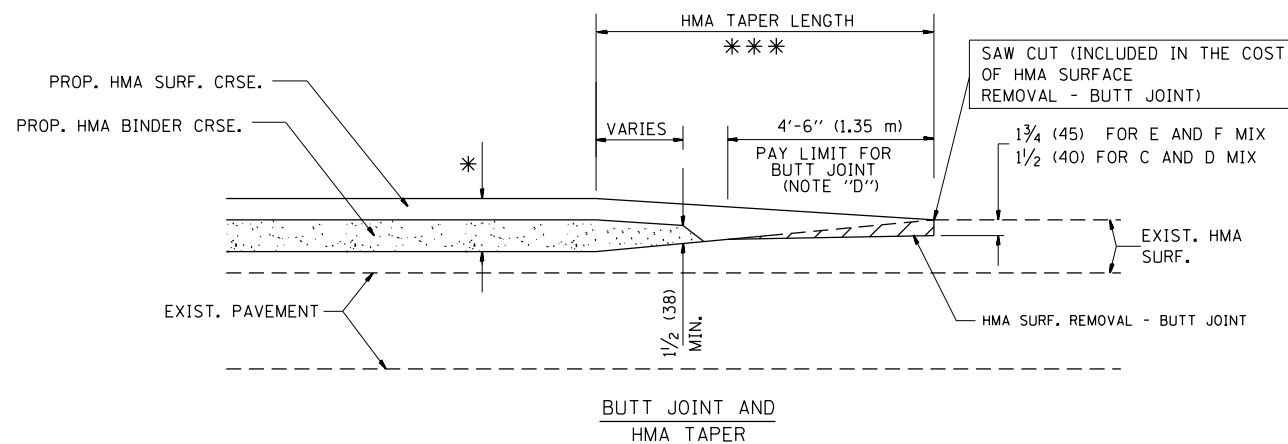

TYPICAL BUTT JOINT AND HMA TAPER FOR MILLING AND RESURFACING

| | | | |
|---|-------------------------------|-----------------------|-----------------------------|
| FILE NAME = | USER NAME = obreueh | DESIGNED - M. DE YONG | REVISED - R. SHAH 10-25-94 |
| et:\pw\work\p1dot\obreueh\d0282900\Dist\d.dgn | | DRAWN - | REVISED - A. ABBAS 03-21-97 |
| | PLOT SCALE = 100.0000' / 1in. | CHECKED - | REVISED - M. GOMEZ 04-06-01 |
| | PLOT DATE = 4/11/2013 | DATE - 06-13-90 | REVISED - R. BORO 01-01-07 |

**STATE OF ILLINOIS
DEPARTMENT OF TRANSPORTATION**

**BUTT JOINT AND
HMA TAPER DETAILS**

SCALE: NONE SHEET NO. 1 OF 1 SHEETS STA. TO STA.

| | | | | |
|---|-------------|--------------------|--------------|-----------|
| F.A.P. RTE. | SECTION | COUNTY | TOTAL SHEETS | SHEET NO. |
| 370 | 2011-089-R5 | COOK | 30 | 23 |
| BD400-05 BD32 | | CONTRACT NO. 60R16 | | |
| FED. ROAD DIST. NO. 1 ILLINOIS FED. AID PROJECT | | | | |