

SCHEDULE OF QUANTITIES  
U. S. 30 (CASS ST) AT HENDERSON AVENUE

NO.	QUANT.	UNIT	DESCRIPTION
1.	1	EACH	MAINTENANCE OF EXISTING TRAFFIC SIGNAL INSTALLATION
2.	1	EACH	MODIFY EXISTING CONTROLLER CABINET
3.	1	EACH	UNINTERRUPTABLE POWER SUPPLY, SPECIAL

NOTE:  
THE EXISTING CONTROLLER IS AN ECONOLITE ASC/2-2000 IN A TYPE IV CABINET.

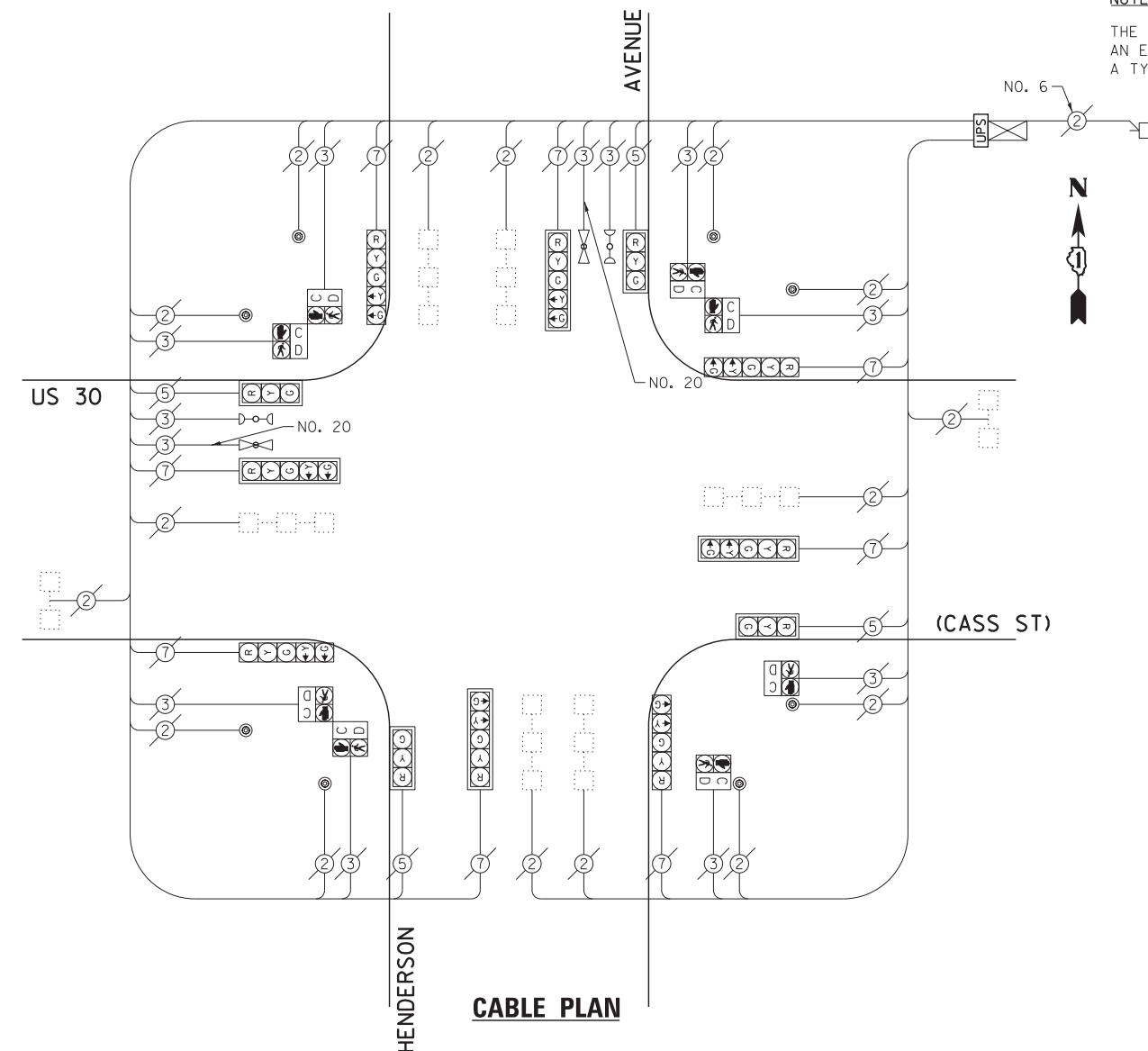

EXISTING CONTROLLER SEQUENCE

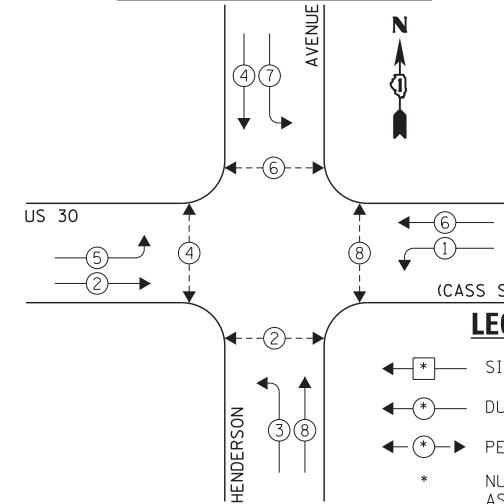

LEGEND:

- ← \* → SINGLE ENTRY PHASE
- ← \* → DUAL ENTRY PHASE
- ← \* → PEDESTRIAN PHASE
- \* NUMBER REFERS TO ASSOCIATED PHASE
- ← \* → OL OVERLAP

EXISTING PHASE DESIGNATION DIAGRAM

EXISTING EMERGENCY VEHICLE PREEMPTION SEQUENCE

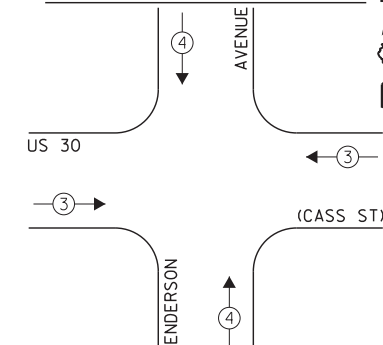

EXISTING EMERGENCY VEHICLE PREEMPTORS	
EMERGENCY VEHICLE PREEMPTOR	3
MOVEMENT	4

I.D.O.T. TRAFFIC SIGNAL INSTALLATION ELECTRICAL SERVICE REQUIREMENTS				TOTAL WATTAGE	
TYPE	NO. LAMPS	WATTAGE	OPERATION		
		INCAND.	L.E.D.		
SIGNAL (RED)	12	135	17	0.50	102.0
SIGNAL (YELLOW)	12	135	25	0.25	75.0
SIGNAL (GREEN)	12	135	15	0.25	45.0
ARROW	16	135	12	0.10	19.2
PED. SIGNAL	8	90	25	1.00	200.0
CONTROLLER	1	-	100	1.00	100.0
LUMINAIRE	-	-	250	0.50	-
L.E.D. ST. NAME SIGN	-	-	64	0.50	-
VIDEO SYSTEM	-	-	150	1.00	-
BATTERY BACKUP	1	-	25	1.00	25.0
ILLUMINATED SIGN	-	-	25	0.05	-
TOTAL =					566.2

ENERGY COSTS - BILLED TO: IL DEPT. OF TRANSPORTATION  
(ADDRESS) 201 W. CENTER COURT  
(ADDRESS) SCHAUMBURG, IL 60196-1096  
ENERGY SUPPLY - CONTACT: TIM COSLET  
PHONE: 815-724-5010  
COMPANY: COMED - JOLIET

THE TRAFFIC SIGNAL CONTROL EQUIPMENT FOR THIS PROJECT SHALL BE "ECONOLITE" TO MATCH THE EXISTING ADJACENT SYSTEM.

FILE NAME = 60W21-045-US30(Cass St)@Henderson Ave.dgn	USER NAME = gwhitten	DESIGNED - JRD	REVISED -
	PLOT SCALE = 1:20	DRAWN - GW3	REVISED -
	PLOT DATE = 3/28/2013	CHECKED - KLB	REVISED -
		DATE - 03-28-13	REVISED -

STATE OF ILLINOIS  
DEPARTMENT OF TRANSPORTATION

SCHEDULE OF QUANTITIES, CABLE PLAN, PHASE DESIGNATION DIAGRAM, & EMERGENCY VEHICLE PREEMPTION SEQUENCE  
US 30 (CASS ST) AT HENDERSON AVENUE

SCALE: SHEET OF SHEETS STA. TO STA.

F.A. RTE.	SECTION	COUNTY	TOTAL SHEETS	SHEET NO.
VAR	2013-003-I	WILL	89	45
CONTRACT NO. 60W21				
ILLINOIS FED. AID PROJECT				