

INDEX OF SHEETS

1. COVER SHEET
2. GENERAL NOTES
3. SUMMARY QUANTITIES
4. TYPICAL SECTIONS
- 5.-6. SCHEDULES - PATCHING
- 7.-8. SCHEDULES - PAVEMENT MARKING
- 9.-11. CLASS B PATCHING DETAILS
12. TYPICAL PAVEMENT MARKING

STANDARDS

- |           |   |
|-----------|---|
| 00Q001-06 | STANDARD SYMBOLS, ABBREVIATIONS AND PATTERNS                                |
| 420701-02 | PAVEMENT FABRIC   |
| 701106-02 | OFF-ROAD OPERATIONS, MULTILANE, MORE THAN 15' (4.5 m) AWAY                  |
| 701301-04 | LANE CLOSURE, 2L, 2W, SHORT TERM OPERATION                                  |
| 701306-03 | LANE CLOSURE, 2L, 2W, SLOW MOVING OPERATIONS DAY ONLY, FOR SPEEDS >= 45 MPH |
| 780001-03 | TYPICAL PAVEMENT MARKINGS   |
| 701901-02 | TRAFFIC CONTROL DEVICES   |

STATE OF ILLINOIS  
DEPARTMENT OF TRANSPORTATION  
DIVISION OF HIGHWAYS

**PROPOSED  
HIGHWAY PLANS**

FAP ROUTE 332 (IL 1)  
SECTION D3 PAVEMENT PATCHING 2014-1

**CLASS B PAVEMENT PATCHING  
WILL COUNTY LINE TO GRANT PARK  
KANKAKEE COUNTY**

C-93-080-13

F.A.P. RTE.	SECTION	COUNTY	TOTAL SHEETS	SHEET NO.
332	D3 PAVEMENT PATCHING 2014-1	KANKAKEE	12	1
		ILLINOIS	CONTRACT NO. 66C85	

D-93-002-13



**BEGIN PROJECT**  
WILL COUNTY LINE  
STA. 49+80

**END PROJECT**  
GRANT PARK  
STA. 247 ± 50

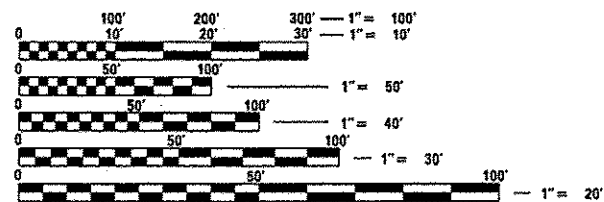

FULL SIZE PLANS HAVE BEEN PREPARED USING STANDARD ENGINEERING SCALES. REDUCED SIZED PLANS WILL NOT CONFORM TO STANDARD SCALES. IN MAKING MEASUREMENTS ON REDUCED PLANS, THE ABOVE SCALES MAY BE USED.

J.U.L.I.E.  
JOINT UTILITY LOCATION INFORMATION FOR EXCAVATION  
1-800-892-0123  
OR 811

DISTRICT NO. (815)-434-6131  
PROJECT ENGINEER: JOE KANNEL P.E.  
UNIT CHIEF: RON WOODSHANK  
TOWNSHIPS: YELLOW HEAD

CONTRACT NO. 66C85

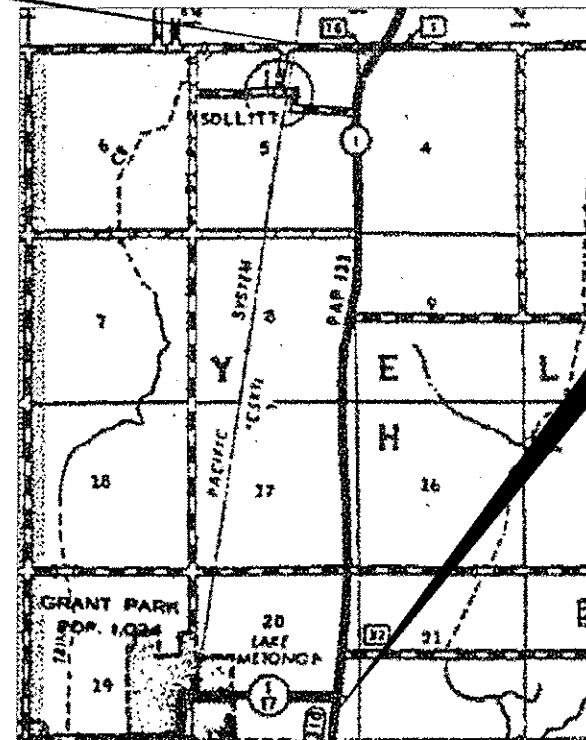

RURAL	
OTHER PRINCIPAL ARTERIAL	
FAP 332 (IL 1)	
2011	
ADT	4,950
P.V.	66.16%
S.U.	7.58%
M.U.	26.26%

STATE OF ILLINOIS  
DEPARTMENT OF TRANSPORTATION  
DIVISION OF HIGHWAYS

SUBMITTED 403 2013  
*Paul R. ...*  
DEPUTY DIRECTOR OF HIGHWAYS, REGION ENGINEER

May 10 2013  
*John D. ...*  
ENGINEER OF DESIGN AND ENVIRONMENT

May 10 2013  
*Onur Osman P.E.*  
DIRECTOR OF HIGHWAYS, CHIEF ENGINEER

**PRINTED BY THE AUTHORITY  
OF THE STATE OF ILLINOIS**

**GENERAL NOTES**

PLAN DIMENSIONS AND DETAILS RELATIVE TO EXISTING PLANS ARE SUBJECT TO NOMINAL CONSTRUCTION VARIATIONS. THE CONTRACTOR SHALL FIELD VERIFY EXISTING DIMENSIONS AND DETAILS AFFECTING NEW CONSTRUCTION AND MAKE NECESSARY APPROVED ADJUSTMENTS PRIOR TO CONSTRUCTION OR ORDERING OF MATERIALS. SUCH VARIATIONS SHALL NOT BE CAUSE FOR ADDITIONAL COMPENSATION FOR A CHANGE IN SCOPE OF WORK; HOWEVER, THE CONTRACTOR WILL BE PAID FOR THE QUANTITY ACTUALLY FURNISHED AT THE UNIT PRICE BID FOR THE WORK.

FOR STABILIZATION, ALL TYPE III BARRICADES SHALL REQUIRE A MINIMUM OF FOUR SAND BAGS PER BARRICADE.

ANY REFERENCE TO A STANDARD IN THESE PLANS SHALL BE INTERPRETED TO MEAN THE EDITION AS INDICATED BY THE SUBNUMBER SHOWN IN THE LIST OF STANDARDS OR THE COPY INCLUDED IN THESE PLANS.

THE CONTRACTOR SHALL CONTACT JULIE AT LEAST 48 HOURS PRIOR TO EXCAVATION TO DETERMINE WHICH UTILITIES ARE IN THE AREA.

**COMMITMENTS**

DISPOSAL OF EXCAVATED MATERIALS. ALL SUITABLE OR UNSUITABLE MATERIALS EXCAVATED DUE TO CONSTRUCTION OPERATIONS SHALL BE DISPOSED OF WITHIN THE LIMITS OF EXISTING RIGHT OF WAY. DISPOSAL OF EXCAVATED MATERIALS OFF THE RIGHT OF WAY SHALL NOT BE PERMITTED.

EXCAVATED MATERIALS SHALL BE DISPOSED OF AT LOCATIONS DIRECTED BY THE ENGINEER. ANY SUCH DISPOSAL SHALL NOT CREATE AND UNSIGHTLY OR OBJECTIONABLE APPEARANCE OR DETRACT FROM THE NATURAL TOPOGRAPHIC FEATURES WITHOUT WRITTEN PERMISSION FROM THE ENGINEER.

STATE OF ILLINOIS  
DEPARTMENT OF TRANSPORTATION  
DISTRICT THREE

PREPARED BY: Dan Proviska  
DISTRICT STUDIES & PLANS ENGINEER

DATE: 4-3-13

EXAMINED BY: Herbert  
DISTRICT CONSTRUCTION ENGINEER

Wayne L Phillips  
DISTRICT MATERIALS ENGINEER

Bruce A. Fisher  
DISTRICT OPERATIONS ENGINEER

FILE NAME *	USER NAME * petelj	DESIGNED - YJP	REVISED -
c:\pwork\pwork\petelj\0333192\0366085-ahd-details.dgn		DRAWN - YJP	REVISED -
	PLOT SCALE * 100,0000 / in	CHECKED - RW	REVISED -
	PLOT DATE * 4/3/2013	DATE -	REVISED -

STATE OF ILLINOIS  
DEPARTMENT OF TRANSPORTATION

**GENERAL NOTES**

SCALE: SHEET 1 OF 1 SHEETS STA. TO STA.

F.A.P. RTE.	SECTION	COUNTY	TOTAL SHEETS	SHEET NO.
332	D3 PAVEMENT PATCHING 2014-1	KANKAKEE	12	2
ILLINOIS FED. AID PROJECT			CONTRACT NO. 66C85	

CODE NO.	ITEM	UNIT	CONSTR. CODE
			STATE FUNDS 100% STATE ROADWAY 0005 RURAL
44200982	CLASS B PATCHES, TYPE II, 11 INCH	SQ YD	1550
44200986	CLASS B PATCHES, TYPE III, 11 INCH	SQ YD	54
44201299	DOWEL BARS 1 1/2"	EACH	3900
44213100	PAVEMENT FABRIC	SQ YD	1604
44213200	SAW CUTS	FOOT	9424
67100100	MOBILIZATION	L SUM	1
70100600	TRAFFIC CONTROL AND PROTECTION, STANDARD 701336	L SUM	1
* 78005110	EPOXY PAVEMENT MARKING - LINE 4"	FOOT	1,356
* 78005130	EPOXY PAVEMENT MARKING - LINE 6"	FOOT	2,140

9 \* SPECIALITY ITEMS

FILE NAME : c:\pw_work\pwidot\patel\j\08333192\0366035-shr-details.dgn	USER NAME : pateluj	DESIGNED - YJP	REVISED -	<b>STATE OF ILLINOIS DEPARTMENT OF TRANSPORTATION</b>	<b>SUMMARY OF QUANTITIES</b>	F.A.P. RTE. 332	SECTION D3 PAVEMENT PATCHING 2014-1	COUNTY KANKAKEE	TOTAL SHEETS 12	SHEET NO. 3	
PLOT SCALE : 100.0000 ' / in.	CHECKED - RW	REVISED -	SCALE:			SHEET 1 OF 1 SHEETS	STA. TO STA.	[ILLINOIS] FED. AID PROJECT CONTRACT NO. 66C85			
PLOT DATE : 4/3/2013	DATE -	REVISED -									

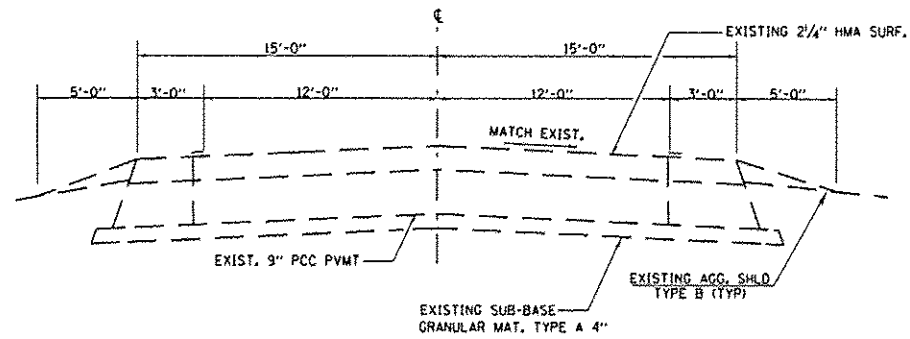

**TYPICAL SECTION 1**

± STA.46+96 TO ± STA.47+61  
 ± STA.70+99 TO ± STA.116+31  
 ± STA.155+95 TO ± STA.186+00  
 ± STA.202+40 TO ± STA.207+02  
 ± STA.219+96 TO ± STA. 243+00

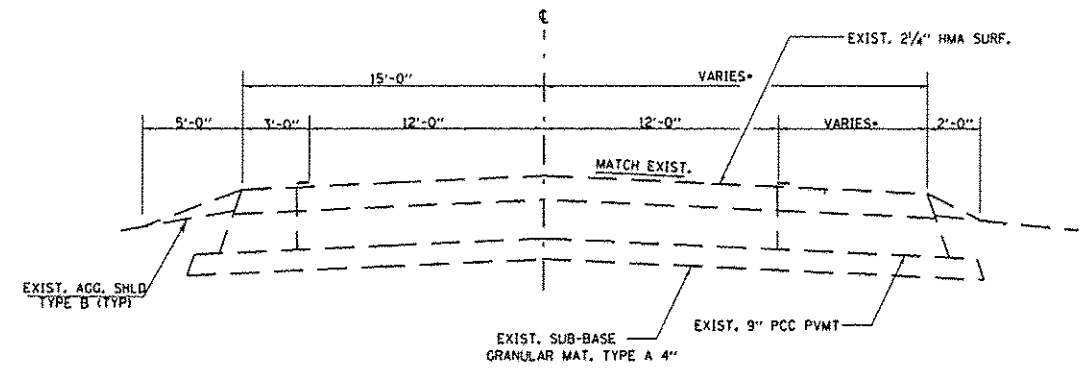

**TYPICAL SECTION 4**

± STA.186+00 TO ± STA.189+20 - 3' TO 16"  
 ± STA.189+20 TO ± STA.192+65 - 16'  
 ± STA.195+75 TO ± STA.199+20 - 16'  
 ± STA.199+20 TO ± STA.202+40 - 16' TO 3'

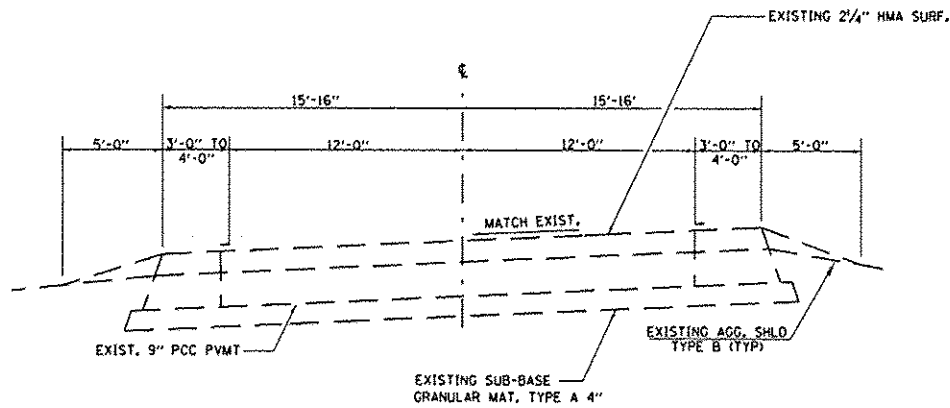

**TYPICAL SECTION 2**

± STA.47+61 TO ± STA.70+99  
 ± STA.135+18 TO ± STA.155+95  
 ± STA.219+96 TO ± STA.243+00

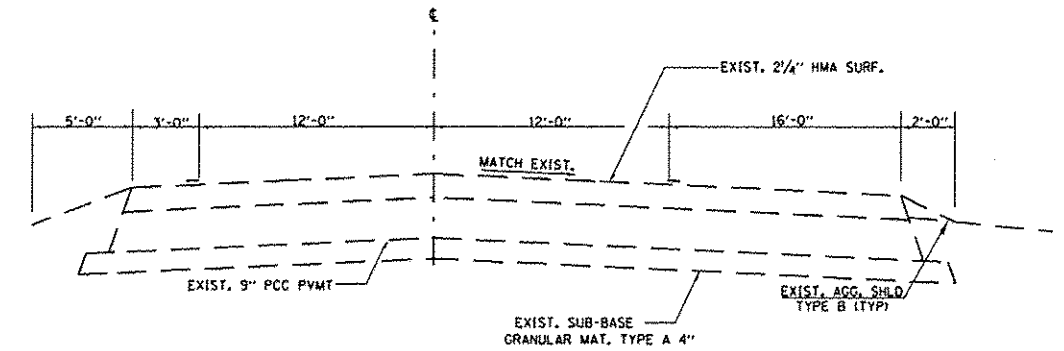

**TYPICAL SECTION 5**

± STA.192+65 TO ± STA.195+75

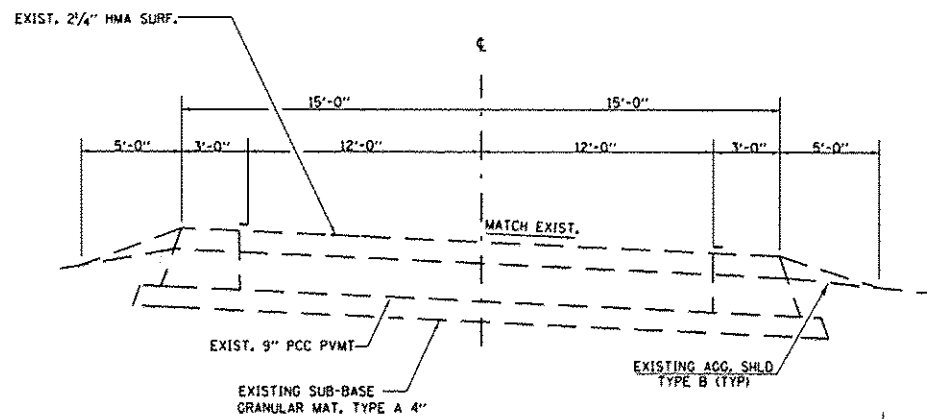

**TYPICAL SECTION 3**

± STA.116+31 TO ± STA.135+18

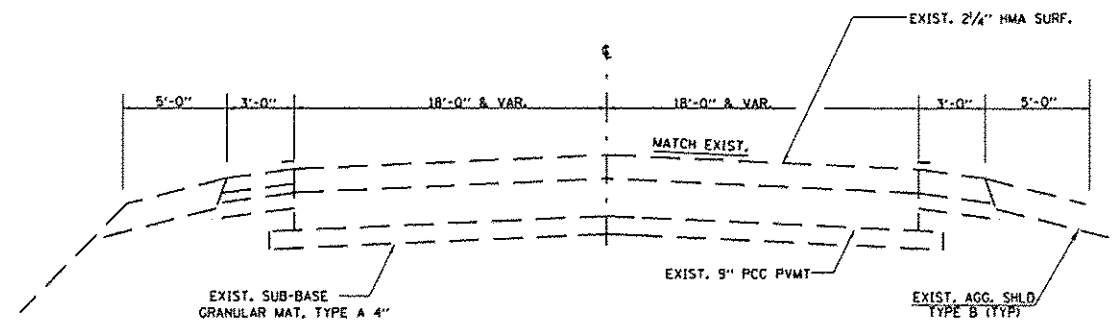

**TYPICAL SECTION 6**

± STA.207+02 TO ± STA.219+96

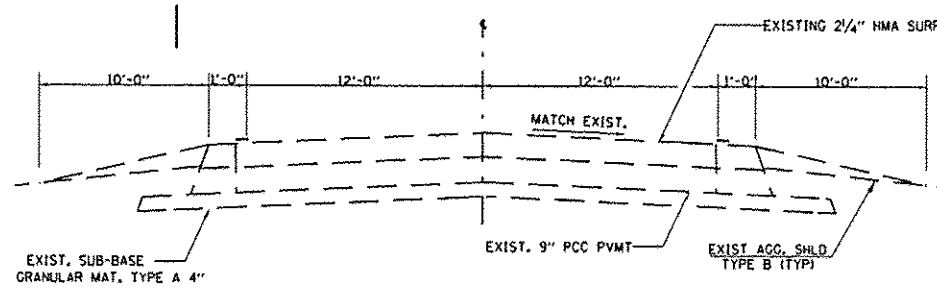

**TYPICAL SECTION 7**

± STA.243+00 TO ± STA.247+24

FILE NAME =	USER NAME = peteluj	DESIGNED - YJP	REVISED -
c:\pwwork\pedit\peteluj\08333192\0366035-shd-details.dgn		DRAWN - YJP	REVISED -
		CHECKED - RW	REVISED -
		DATE -	REVISED -

STATE OF ILLINOIS  
 DEPARTMENT OF TRANSPORTATION

**TYPICAL SECTIONS**

SCALE: SHEET 1 OF 2 SHEETS STA. TO STA.

F.A.P. RTE.	SECTION	COUNTY	TOTAL SHEETS	SHEET NO.
332	03 PAVEMENT PATCHING 2014-1	KANKAKEE	12	4
ILLINOIS FED. AID PROJECT			CONTRACT NO. 66C85	

PATCHING SCHEDULE - NORTHBOUND LANE					
LOCATION	CLASS B PATCHING		DOWEL BARS	SAW CUTS	PAVE'T FABRIC
	TYPE II	TYPE III			
	STATION	SQ YD	SQ YD	EACH	FOOT
49+80	8		20	48	8
50+25	8		20	48	8
51+00	8		20	48	8
61+00	8		20	48	8
61+50	8		20	48	8
63+00	8		20	48	8
65+75	8		20	48	8
66+50	8		20	48	8
70+00	8		20	48	8
71+25	8		20	48	8
72+50	8		20	48	8
74+25	8		20	48	8
76+30	8		20	48	8
77+50	8		20	48	8
78+00	8		20	48	8
79+00	8		20	48	8
80+00	8		20	48	8
81+25	8		20	48	8
82+00	8		20	48	8
82+75	8		20	48	8
83+00	11		20	52	11
85+00	8		20	48	8
86+25	8		20	48	8
87+50	8		20	48	8
92+00	8		20	48	8
93+50	8		20	48	8
96+25	8		20	48	8
97+25	8		20	48	8
100+00	8		20	48	8
101+25	8		20	48	8
105+00	8		20	48	8
107+50	8		20	48	8
110+00	8		20	48	8
112+00	8		20	48	8
115+00	8		20	48	8
120+00	8		20	48	8
122+75	8		20	48	8
125+00	8		20	48	8
126+25	8		20	48	8
127+00	8		20	48	8
135+00	8		20	48	8
137+00	8		20	48	8
141+25	8		20	48	8
142+50	8		20	48	8
146+25	8		20	48	8
153+50	8		20	48	8
159+50	8		20	48	8

PATCHING SCHEDULE - NORTHBOUND LANE -CONT'D					
LOCATION	CLASS B PATCHING		DOWEL BARS	SAW CUTS	PAVE'T FABRIC
	TYPE II	TYPE III			
	STATION	SQ YD	SQ YD	EACH	FOOT
160+25	8		20	48	8
162+00	8		20	48	8
163+00	8		20	48	8
165+00	8		20	48	8
166+00	8		20	48	8
167+75	8		20	48	8
170+00	8		20	48	8
175+00	8		20	48	8
176+25	8		20	48	8
179+25	8		20	48	8
181+25	8		20	48	8
182+00	8		20	48	8
182+50	8		20	48	8
183+50	8		20	48	8
184+50	8		20	48	8
185+25	8		20	48	8
186+25	8		20	48	8
189+25	8		20	48	8
191+25	8		20	48	8
192+00	8		20	48	8
194+00	8		20	48	8
195+75	8		20	48	8
197+50	8		20	48	8
198+25	8		20	48	8
199+50	8		20	48	8
200+00	8		20	48	8
203+25	8		20	48	8
204+00	8		20	48	8
205+00	8		20	48	8
209+50	11		20	52	11
211+50	8		20	48	8
9000 N RD (SOUTH)	8		20	48	8
220+00	11		20	52	11
225+00	8		20	48	8
226+25	8		20	48	8
229+00	8		20	48	8
230+00	8		20	48	8
231+25	8		20	48	8
232+30	8		20	48	8
237+00	8		20	48	8
239+75		16	20	60	16
240+00	8		20	48	8
242+00	8		20	48	8
243+60	8		20	48	8
244+15	8		20	48	8
245+80	8		20	48	8
	0,0			0	0
NB TOTALS	745	16	1,860	4,488	761

PATCHING SCHEDULE					
LOCATION	SOUTHBOUND LANE				
	CLASS B PATCHING		DOWEL	SAW	PAVE'T
	TYPE II	TYPE III	BAR	CUTS	FABRIC
STATION	SO YD	SO YD	EACH	FOOT	SO YD
49+80	8		20	48	8
51+00	8		20	48	8
61+50	8		20	48	8
63+00	8		20	48	8
65+00	8		20	48	8
65+75	8		20	48	8
66+50	8		20	48	8
70+00	8		20	48	8
71+25	8		20	48	8
72+50	8		20	48	8
73+25	8		20	48	8
74+25	8		20	48	8
75+00	8		20	48	8
76+30	8		20	48	8
77+50	8		20	48	8
78+00	8		20	48	8
79+00	8		20	48	8
80+00	8		20	48	8
81+25	8		20	48	8
82+00	8		20	48	8
82+75	8		20	48	8
83+00	8		20	48	8
85+00	8		20	48	8
86+25	8		20	48	8
87+50	8		20	48	8
89+50	8		20	48	8
90+00	8		20	48	8
93+50	8		20	48	8
95+00	8		20	48	8
96+25	8		20	48	8
97+25	8		20	48	8
98+50	8		20	48	8
100+00	8		20	48	8
101+25	8		20	48	8
105+00	8		20	48	8
107+50	8		20	48	8
110+00	8		20	48	8
112+00	8		20	48	8
112+75	8		20	48	8
115+00	8		20	48	8
116+50	8		20	48	8
119+25	8		20	48	8
120+00	8		20	48	8
122+75	8		20	48	8
127+00	8		20	48	8
135+00	8		20	48	8
137+00	8		20	48	8
141+25	8		20	48	8
146+25	8		20	48	8
157+00	8		20	48	8
159+50	8		20	48	8
160+25	8		20	48	8
162+00	8		20	48	8
163+00	8		20	48	8
165+00	8		20	48	8
166+00	8		20	48	8
166+75	8		20	48	8
167+75	8		20	48	8
170+00	8		20	48	8

PATCHING SCHEDULE					
LOCATION	SOUTHBOUND LANE - CONT'D				
	CLASS B PATCHING		DOWEL	SAW	PAVE'T
	TYPE II	TYPE III	BAR	CUTS	FABRIC
STATION	SO YD	SO YD	EACH	FOOT	SO YD
175+00	8		20	48	8
179+25	8		20	48	8
180+00	8		20	48	8
181+25	8		20	48	8
182+50	8		20	48	8
183+50	8		20	48	8
184+50	8		20	48	8
185+25	8		20	48	8
186+25	8		20	48	8
187+50	8		20	48	8
189+25	8		20	48	8
191+25	8		20	48	8
197+50	8		20	48	8
200+00	8		20	48	8
201+25	8		20	48	8
203+25	8		20	48	8
204+00	8		20	48	8
205+00	8		20	48	8
207+50	8		20	48	8
207+80	8		20	48	8
209+50	8		20	48	8
211+50	8		20	48	8
9000 N RD (NORTH)	8		20	48	8
9000 N RD (SOUTH)	8		20	48	8
219+50	8		20	48	8
220+00	11		20	52	11
225+00	8		20	48	8
226+25		16	20	60	16
229+00	8		20	48	8
230+00	8		20	48	8
231+25	8		20	48	8
232+00	11		20	52	11
232+30	8		20	48	8
233+00	8		20	48	8
234+80	8		20	48	8
235+15	8		20	48	8
237+00	8		20	48	8
239+75		21	20	68	21
242+00	8		20	48	8
243+60	8		20	48	8
244+15	8		20	48	8
245+80	8		20	48	8
247+50	8		20	48	8
	0		20	0	0
SB TOTALS	806	38	2,040	4,936	843

PAVEMENT MARKING SCHEDULE - NBL			
LOCATION	EPOXY PAVEMENT MARKING LINE 4"		EPOXY PAVEMENT MARKING LINE 6"
	FEET		FEET
	YELLOW	WHITE	YELLOW
49+80		6	10
50+25		6	10
51+00		6	10
61+00		6	10
61+50		6	10
63+00		6	10
65+00		6	10
65+75		6	10
66+50		6	10
70+00		6	10
71+25		6	10
72+50		8	10
74+25		6	10
76+30		6	10
77+50		6	10
78+00		6	10
79+00		6	10
80+00		6	10
81+25		6	10
82+00		6	10
82+75		6	10
83+00		8	10
85+00		6	10
86+25		6	10
87+50		6	10
92+00		6	10
93+50		6	10
96+25		6	10
97+25		6	10
100+00		6	10
101+25		6	10
105+00		6	10
107+50		6	10
110+00		6	10
112+00		6	10
115+00		6	10
120+00		6	10
122+75		6	10
125+00		6	10
126+25		6	10
127+00		6	10
135+00		6	10
137+00		6	10
141+25		6	10
142+50		6	10
146+25		6	10
153+50		6	10
159+50		6	10
160+25		6	10

PAVEMENT MARKING SCHEDULE - NBL -CONT'D			
LOCATION	EPOXY PAVEMENT MARKING LINE 4"		EPOXY PAVEMENT MARKING LINE 6"
	FEET		FEET
	YELLOW	WHITE	YELLOW
162+00		6	10
163+00		6	10
165+00		6	10
166+00		6	10
166+75		6	10
167+75		6	10
170+00		6	10
175+00		6	10
176+25		6	10
179+25		6	10
181+25		6	10
182+00		6	10
182+50		6	10
183+50		6	10
184+50		6	10
185+25		6	10
186+25		6	10
187+50		6	10
189+25		6	10
191+25		6	10
192+00		6	10
194+00		6	10
195+75		6	10
197+50		6	10
198+25		6	10
199+50		6	10
200+00		6	10
201+25		6	10
203+25		6	10
204+00		6	10
205+00		6	10
209+50	10	8	20
211+50	10	6	20
9000 N RD (SOUTH)	10	6	20
220+00		8	10
225+00		6	10
226+25		6	10
229+00		6	10
230+00		6	10
231+25		6	10
232+00		6	10
232+30		6	10
233+00		6	10
234+80		6	10
235+15		6	10
237+00		6	10
239+75		10	10
240+00		6	10
242+00		6	10
243+60		6	10
244+15		6	10
245+80		6	10
SUBTOTAL	30	618	
TOTAL	648		1,040



PAVEMENT MARKING SCHEDULE - SBL			
LOCATION  STATION	EPOXY PAVEMENT MARKING LINE 4"		EPOXY PAVEMENT MARKING LINE 6"
	FEET		FEET
	YELLOW	WHITE	YELLOW
49+80		6	10
50+25		6	10
51+00		6	10
61+50		6	10
63+00		6	10
65+00		6	10
65+75		6	10
66+50		6	10
70+00		6	10
71+25		6	10
72+50		6	10
73+25		6	10
74+25		6	10
75+00		6	10
76+30		6	10
77+50		6	10
78+00		6	10
79+00		6	10
80+00		6	10
81+25		6	10
82+00		6	10
82+75		6	10
83+00		6	10
85+00		6	10
86+25		6	10
87+50		6	10
89+50		6	10
90+00		6	10
93+50		6	10
95+00		6	10
96+25		6	10
97+25		6	10
98+50		6	10
100+00		6	10
101+25		6	10
105+00		6	10
107+50		6	10
110+00		6	10
112+00		6	10
112+75		6	10
115+00		6	10
116+50		6	10
119+25		6	10
120+00		6	10
122+75		6	10
127+00		6	10
135+00		6	10
137+00		6	10
141+25		6	10
146+25		6	10

PAVEMENT MARKING SCHEDULE - SBL-CONT'D			
LOCATION  STATION	EPOXY PAVEMENT MARKING LINE 4"		EPOXY PAVEMENT MARKING LINE 6"
	FEET		FEET
	YELLOW	WHITE	YELLOW
157+00		6	10
159+50		6	10
160+25		6	10
162+00		6	10
163+00		6	10
165+00		6	10
166+00		6	10
166+75		6	10
167+75		6	10
170+00		6	10
175+00		6	10
179+25		6	10
180+00		6	10
181+25		6	10
182+50		6	10
183+50		6	10
184+50		6	10
185+25		6	10
186+25		6	10
187+50		6	10
189+25		6	10
191+25		6	10
197+50		6	10
200+00		6	10
201+25		6	10
203+25		6	10
204+00		6	10
205+00		6	10
207+50	10	6	20
207+80	10	6	20
209+50	10	6	20
211+50	10	6	20
9000 N RD (NORTH)	10	6	20
9000 N RD (SOUTH)	10	6	20
219+50	10	6	20
220+00		8	10
225+00		6	10
226+25		12	10
229+00		6	10
230+00		6	10
231+25		6	10
232+00		8	10
232+30		6	10
233+00		6	10
234+80		6	10
235+15		6	10
237+00		6	10
239+75		16	10
242+00		6	10
243+60		6	10
244+15		6	10
245+80		6	10
247+50		6	10
SUBTOTAL	70	638	
TOTAL	708		1,100

FILE NAME =	USER NAME = patelij	DESIGNED - YJP	REVISED -
c:\pr_work\pawid\patelij\08333192\036603-shd-details.dgn		DRAWN - YJP	REVISED -
		CHECKED - RW	REVISED -
		DATE -	REVISED -

STATE OF ILLINOIS  
DEPARTMENT OF TRANSPORTATION

SCHEDULES - PAVEMENT MARKING

SCALE: SHEET 2 OF 2 SHEETS STA. TO STA.

F.A.P. RTE.	SECTION	COUNTY	TOTAL SHEETS	SHEET NO.
332	D3 PAVEMENT PATCHING 2014-1	KANKAKEE	12	8
CONTRACT NO. 66C05			ILLINOIS FED. AID PROJECT	



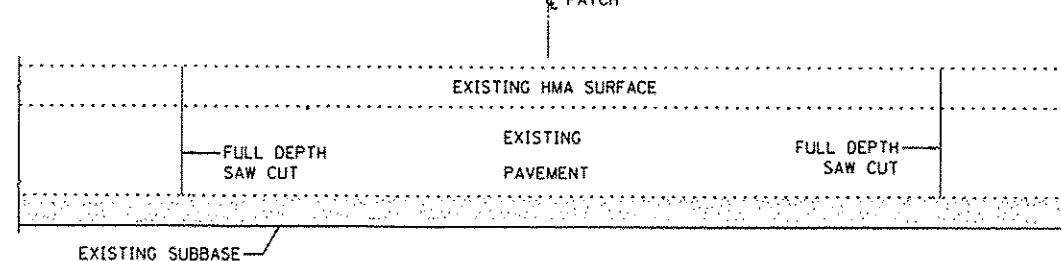
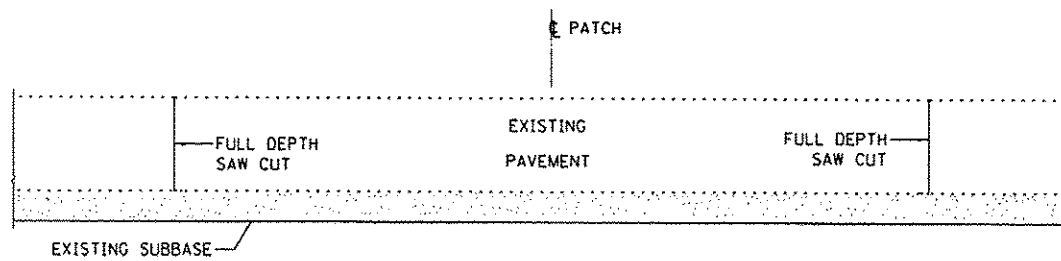
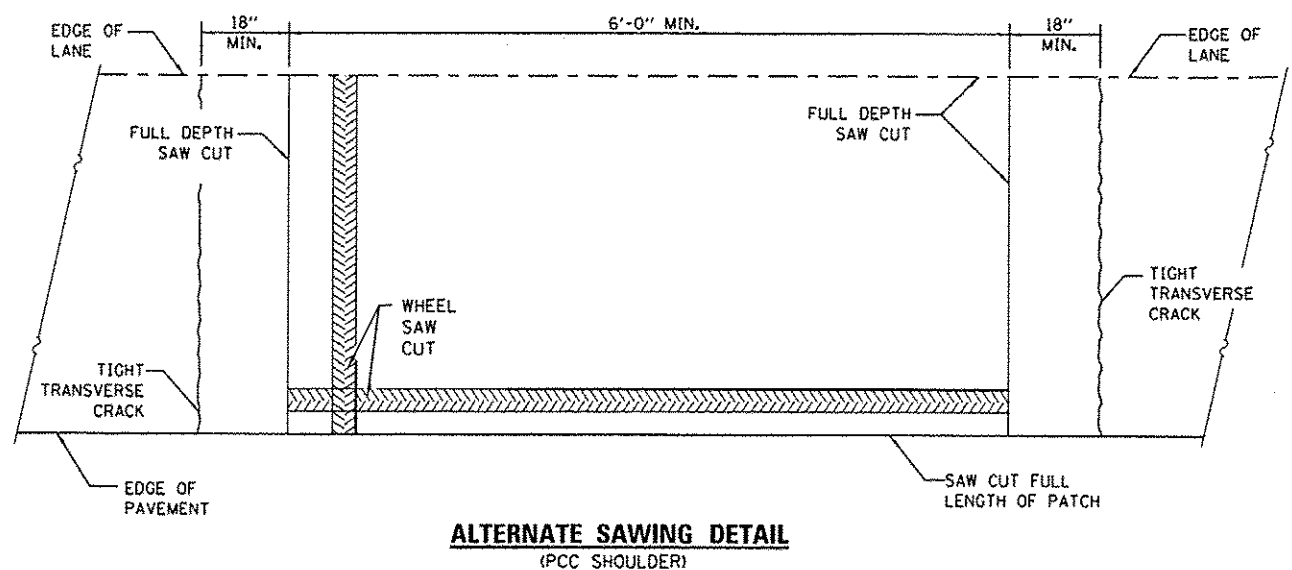
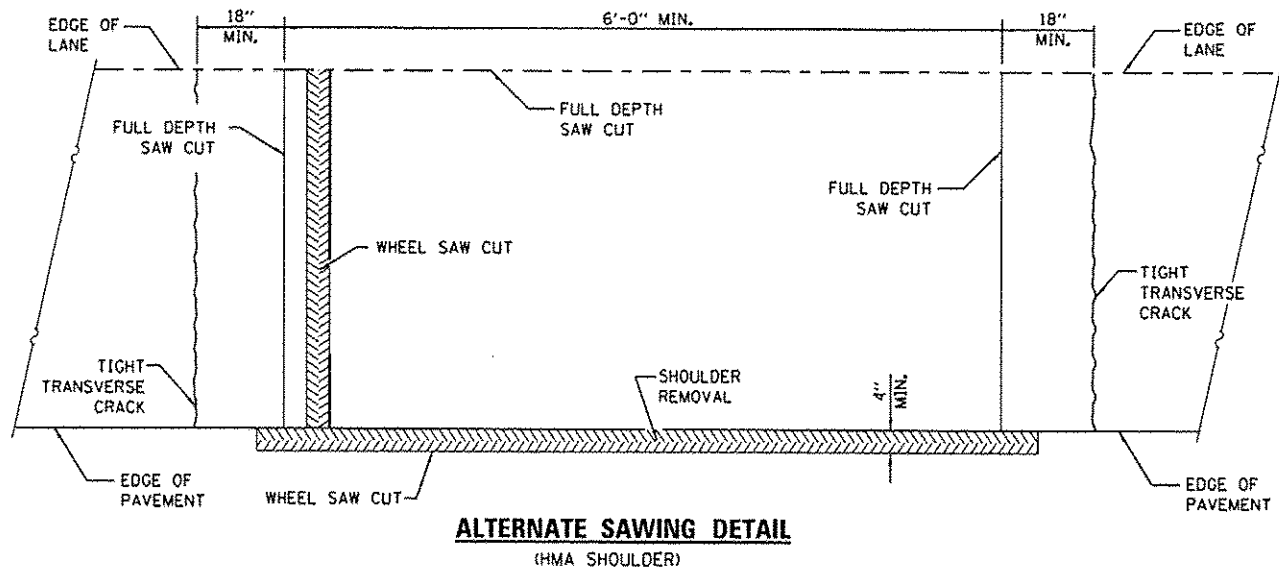
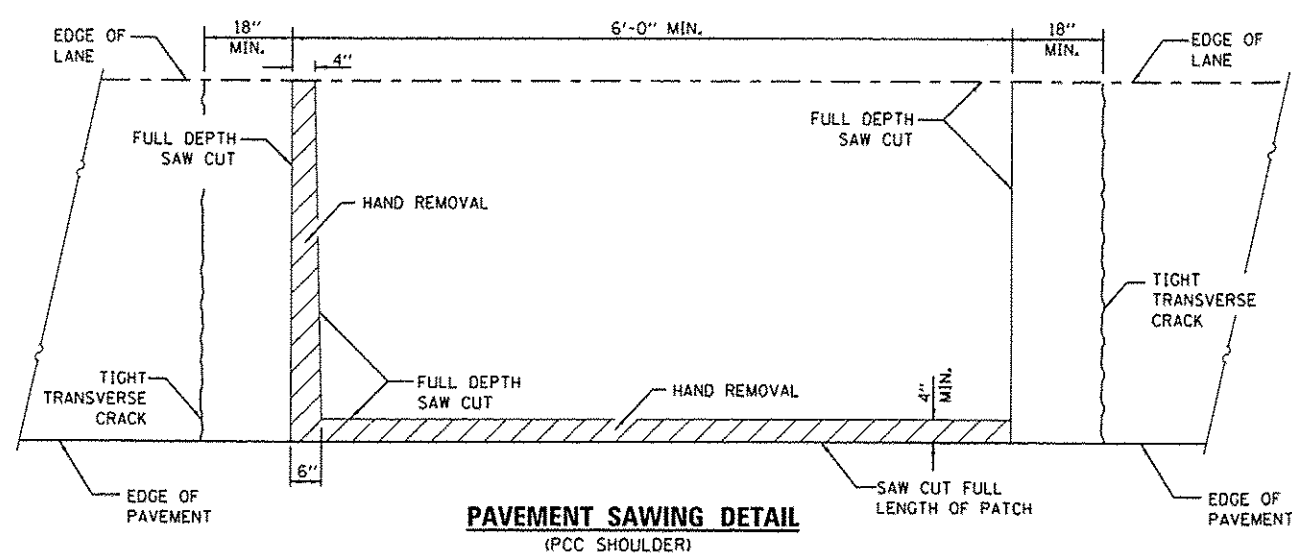
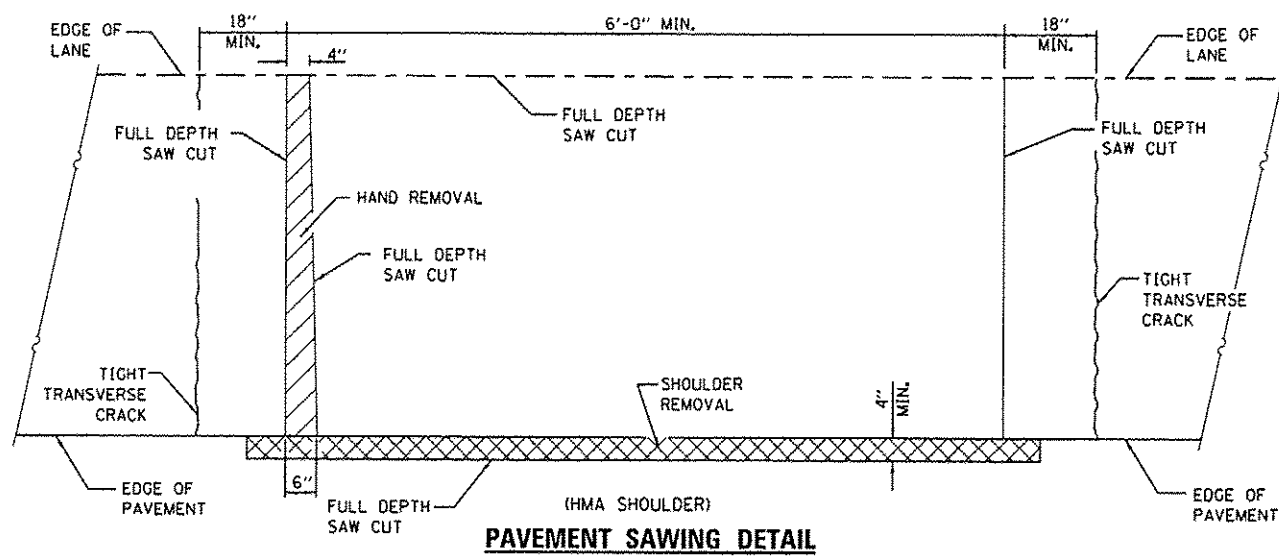

**GENERAL NOTES**

THE TRANSVERSE JOINTS FOR CLASS B PATCHES SHALL ALIGN WITH JOINTS OR CRACKS IN THE ADJACENT LANE WHENEVER POSSIBLE.

SEE STANDARD 420701 FOR DDETAIL OF PAVEMENT FABRIC.

FILE NAME =	USER NAME = patelyj	DESIGNED - YJP	REVISED -
c:\p\work\pawdot\patelyj\08333192\036603-shr-details.dgn		DRAWN - YJP	REVISED -
		CHECKED - RW	REVISED -
		DATE -	REVISED -

STATE OF ILLINOIS  
DEPARTMENT OF TRANSPORTATION

**CLASS B PATCHING DETAILS**

SCALE: SHEET 1 OF 1 SHEETS STA. TO STA.

F.A.P. RTE.	SECTION	COUNTY	TOTAL SHEETS	SHEET NO.
332	03 PAVEMENT PATCHING 2014-1	KANKAKEE	12	9
CONTRACT NO. 66C85			ILLINOIS FED. AID PROJECT	

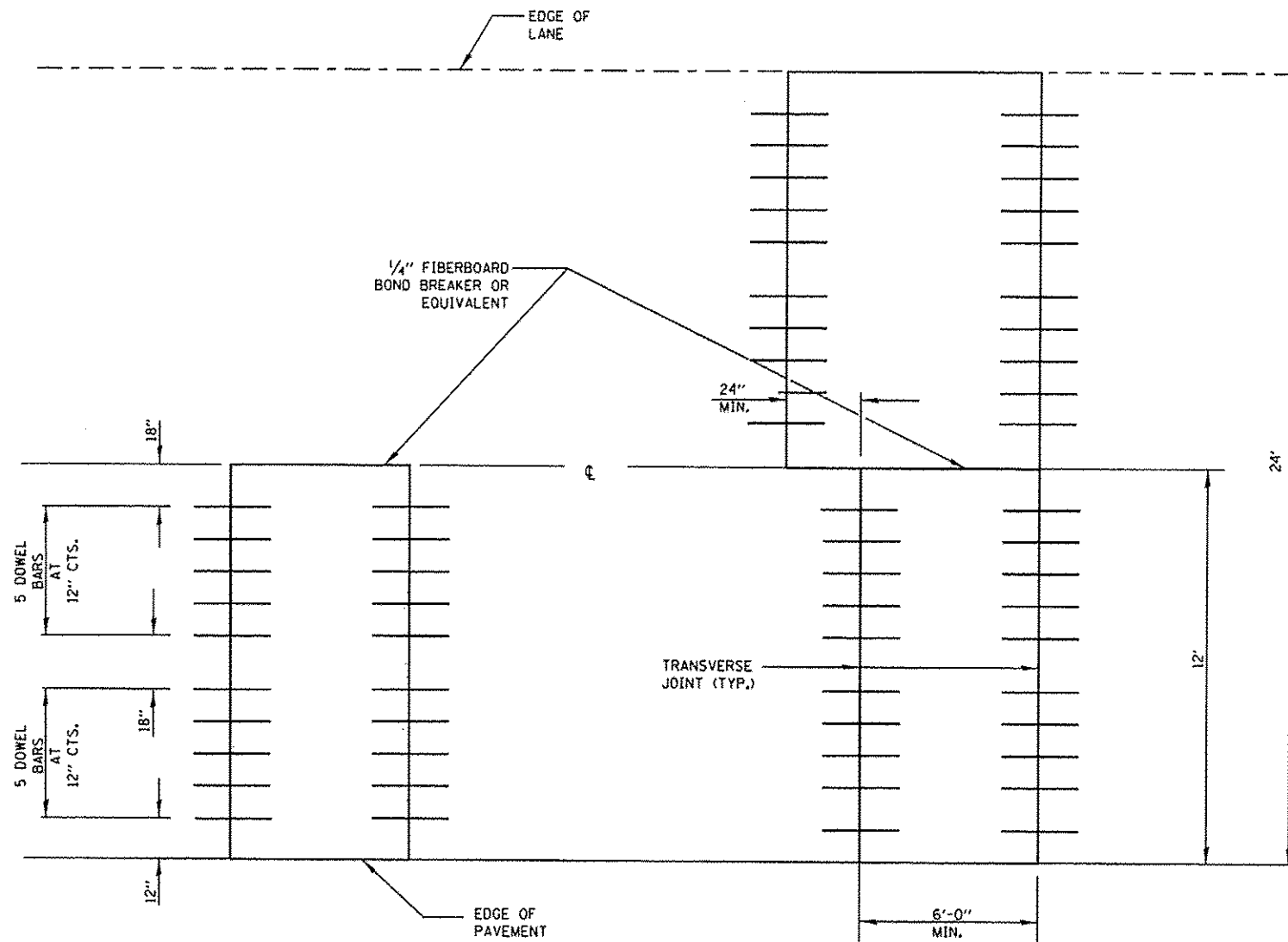

**12' (3.6 m) WIDE LANES**

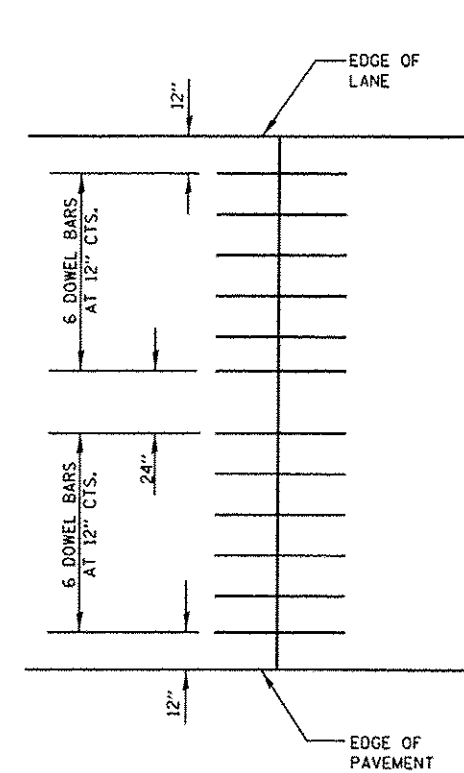

**14' WIDE RAMP**

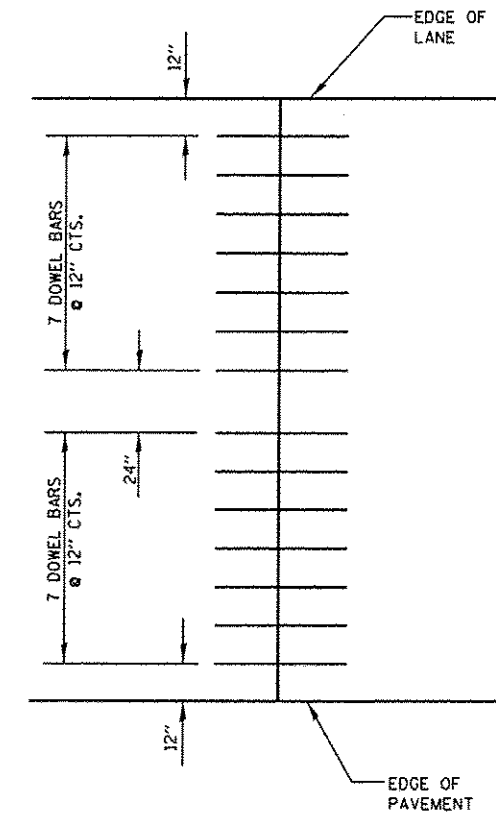

**16' WIDE RAMP**

FILE NAME :	USER NAME : patelyj	DESIGNED - YJP	REVISED -	<b>STATE OF ILLINOIS DEPARTMENT OF TRANSPORTATION</b>	<b>CLASS B PATCHING DETAILS</b>	F.A.P. RTE.	SECTION	COUNTY	TOTAL SHEETS	SHEET NO.
ci:\pw\work\priedot\patelyj\08033192\0366033-shc-details.dgn	DRAWN - YJP	REVISED -	332			D3 PAVEMENT PATCHING 2014-1	KANKAKEE	12	10	
PLOT SCALE = 100.0000' / in.	CHECKED - RW	REVISED -	CONTRACT NO. 66C85							
PLOT DATE = 4/3/2013	DATE -	REVISED -	ILLINOIS FED. AID PROJECT							
SCALE:					SHEET 1 OF 1 SHEETS	STA. TO STA.				

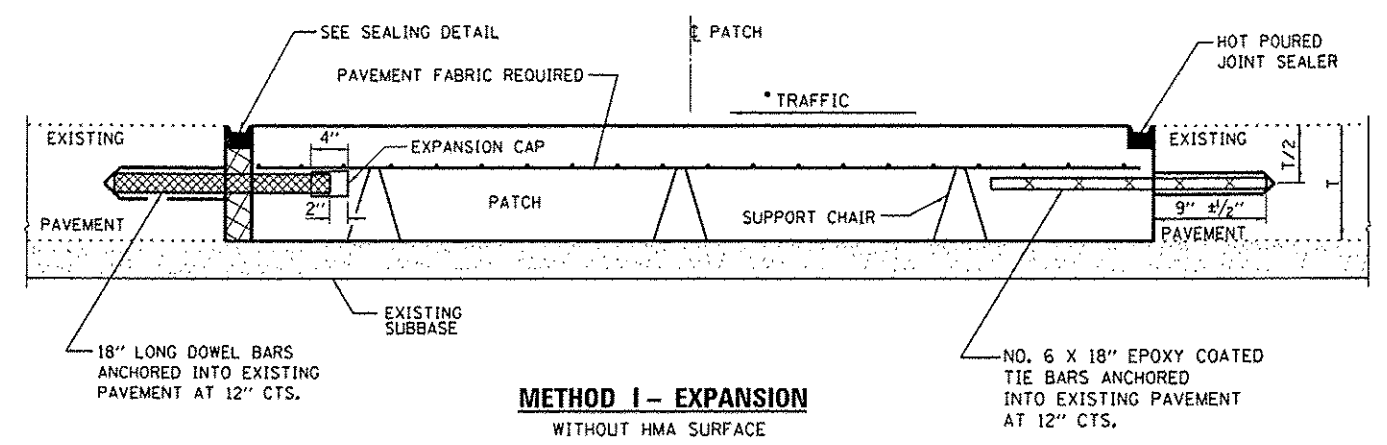
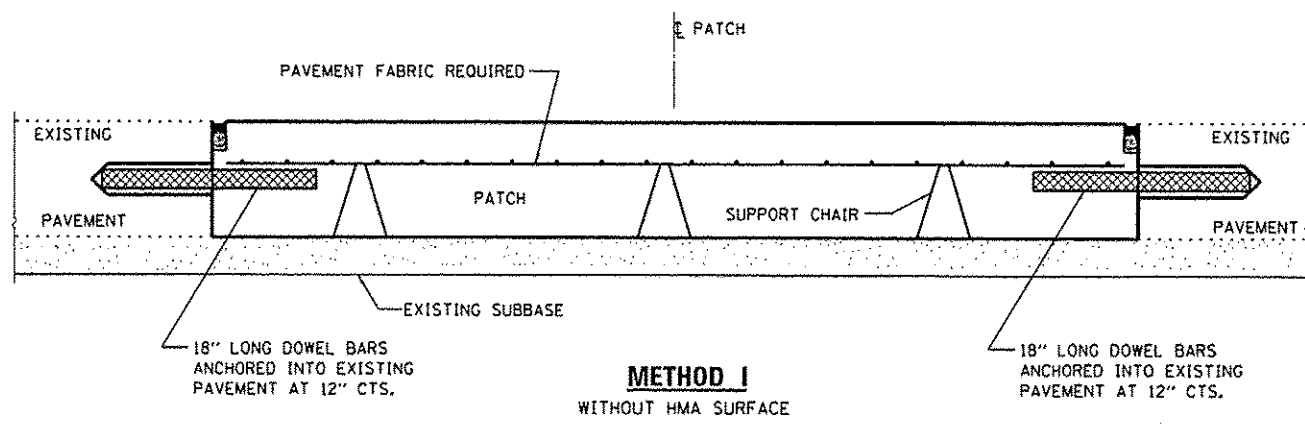

DOWEL BAR TABLE		
PAVEMENT THICKNESS	DOWEL BAR DIAMETER	HOLE DIAMETER
8" OR GREATER	1 1/2"	1 5/8"
7" THRU 7 5/8"	1 1/4"	1 3/8"
LESS THAN 7"	1"	1 1/8"

**NOTE**

- WHEN RE-ESTABLISHING A TRANSVERSE EXPANSION JOINT ON A TWO-LANE, TWO-WAY ROAD, REVERSE THE ORIENTATION OF THE DOWEL BARS WITH RESPECT TO TRAFFIC FOR ONE OF THE PATCHES SUCH THAT THE JOINT WILL BE CONTINUOUS ACROSS BOTH LANES.

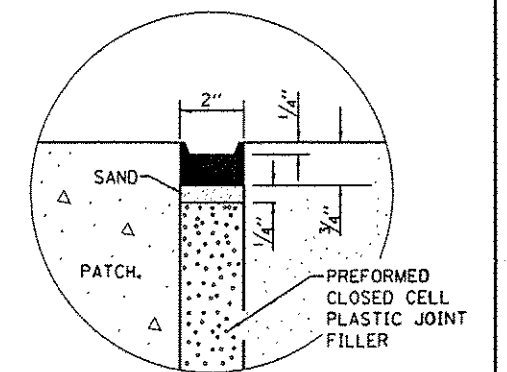
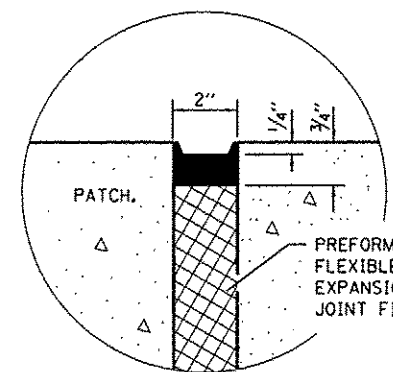
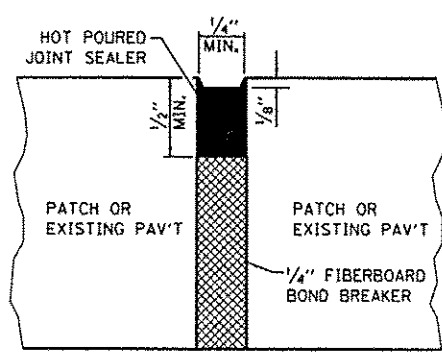
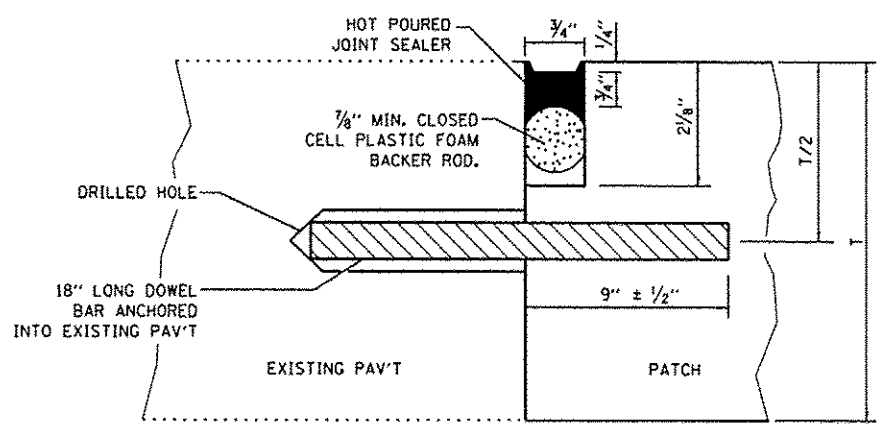
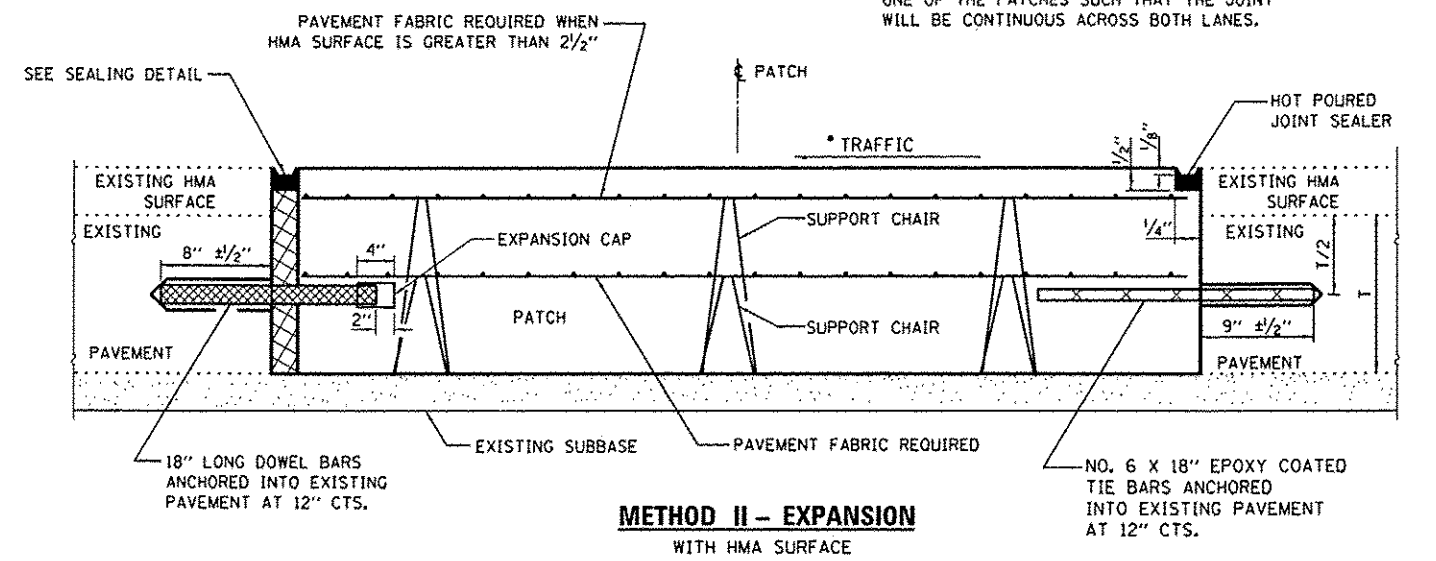
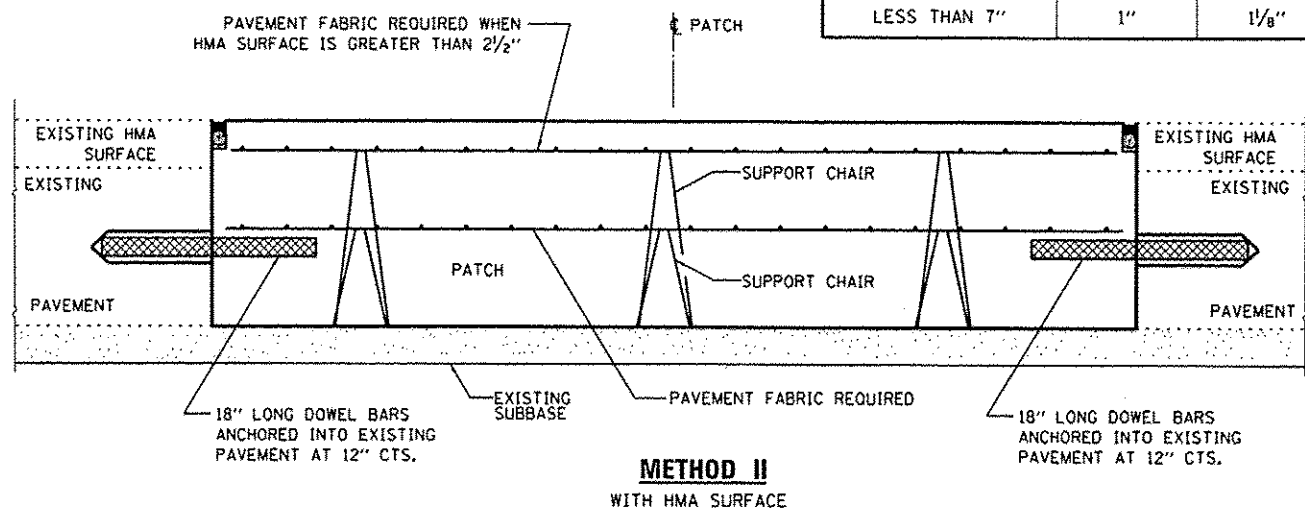

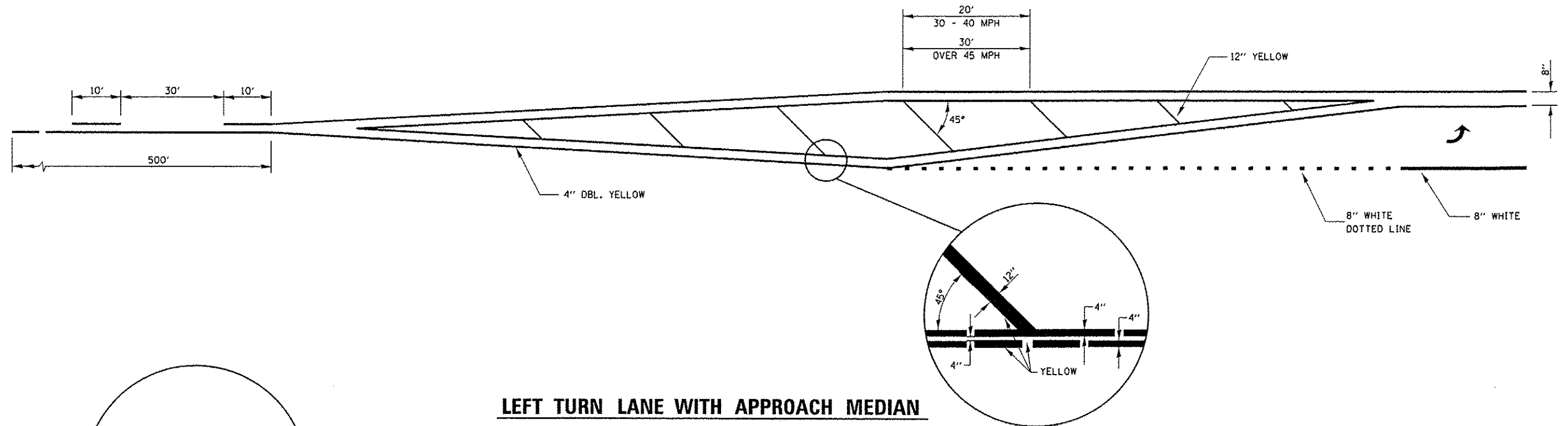

**LEFT TURN LANE WITH APPROACH MEDIAN**

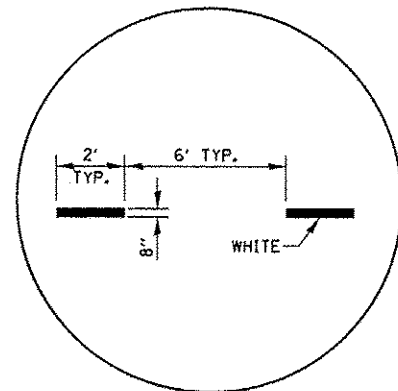

**ADVANCE AND INTERSECTION LANE DIVIDER LINES**



**LEFT TURN LANE TYPICAL APPLICATION**

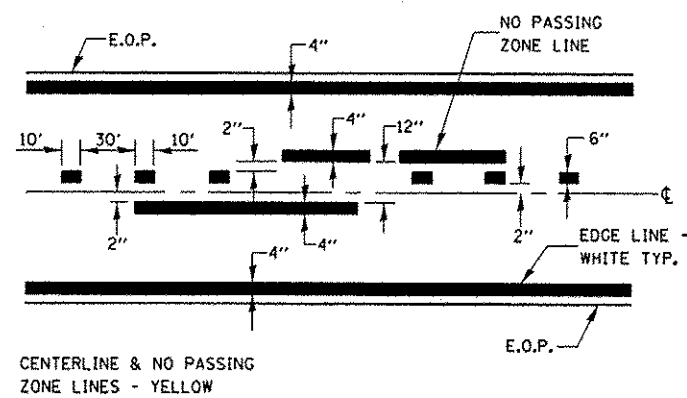

CENTERLINE & NO PASSING ZONE LINES - YELLOW

**PAVEMENT MARKING 2-LANE ROAD**

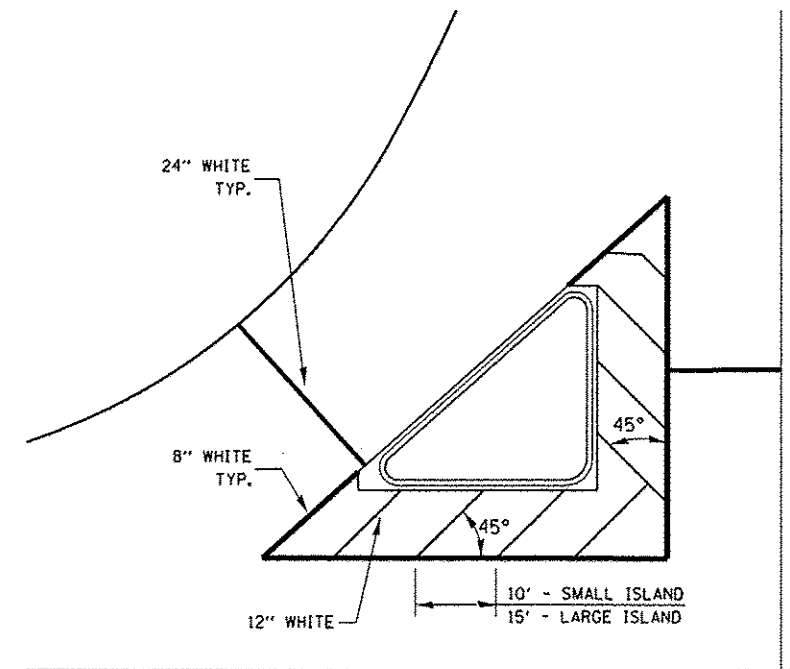

**TYPICAL ISLAND**

FILE NAME =	USER NAME = potelyj	DESIGNED - YJP	REVISED -	<b>STATE OF ILLINOIS DEPARTMENT OF TRANSPORTATION</b>	<b>TYPICAL PAVEMENT MARKING</b>	F.A.P. RTE.	SECTION	COUNTY	TOTAL SHEETS	SHEET NO.
ci:\pw\work\pavdot\potelyj\18033192\0366035-shr-details.dgn	DRAWN - YJP	REVISED -	332			D3 PAVEMENT PATCHING 2014-1	KANKAKEE	12	12	
PLOT SCALE = 100.0000' / 1"	CHECKED - RW	REVISED -	CONTRACT NO. 66C85							
PLOT DATE = 4/3/2013	DATE -	REVISED -	ILLINOIS FED. AID PROJECT							
					SCALE:	SHEET 1 OF 1 SHEETS		STA.	TO STA.	