

FAI ROUTE 55  
PRE-STAGE 1 TYPICAL CROSS SECTIONS  
SN 054-0065, 0066, 0067, 0068  
(17) STA 447+14.21 TO STA 448+18.46 (19)

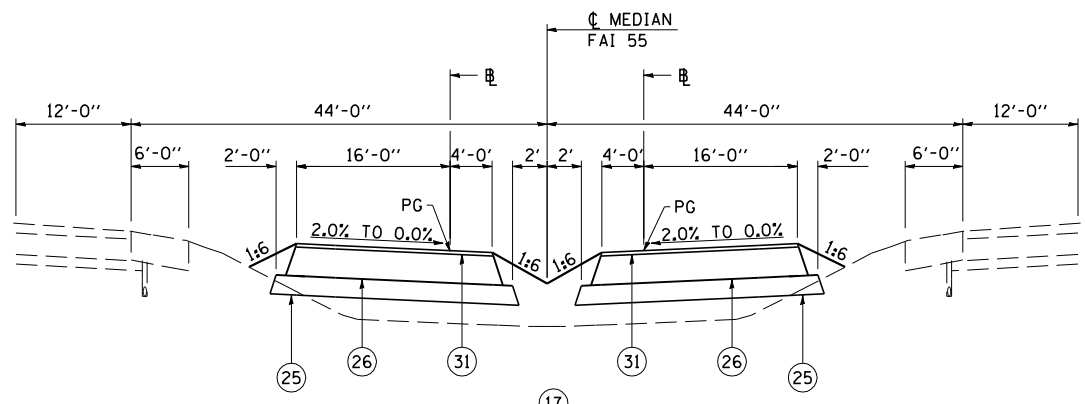

FAI ROUTE 55  
PRE-STAGE 1 TYPICAL CROSS SECTIONS  
SN 054-0065, 0066, 0067, 0068

SB I-55  
(16) STA 446+45.89 TO STA 447+14.21 (18)

NB I-55  
(16) STA 446+36.32 TO STA 447+14.21 (18)

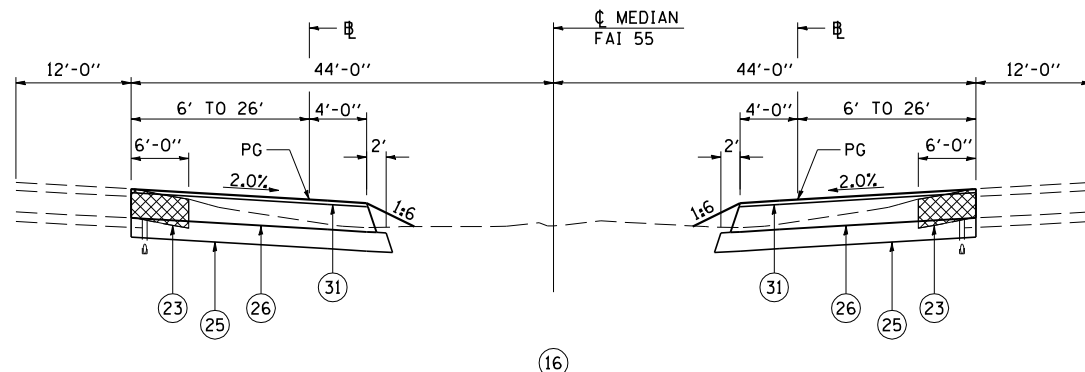

FAI ROUTE 55  
PRE-STAGE 1 TYPICAL CROSS SECTIONS  
SN 054-0065, 0066, 0067, 0068

SB I-55  
STA 443+36.78 TO STA 446+45.89 (17)

NB I-55  
STA 443+27.15 TO STA 446+36.32 (17)

LEGEND

- 1 EX STABILIZED SUBBASE 4"
- 2 EX CONTINUOUSLY REINFORCED PORTLAND CEMENT CONCRETE PAVEMENT 9"
- 3 EX PORTLAND CEMENT CONCRETE PAVEMENT 8"
- 4 EX PORTLAND CEMENT CONCRETE PAVEMENT 10"
- 5 EX HOT-MIX ASPHALT RESURFACING 1 1/2"
- 6 EX HOT-MIX ASPHALT RESURFACING 3 1/4"
- 7 EX HOT-MIX ASPHALT RESURFACING 4 3/4"
- 8 EX HOT-MIX ASPHALT SHOULDERS 12"
- 9 EX HOT-MIX ASPHALT SHOULDERS 12 1/4"
- 10 EX HOT-MIX ASPHALT SHOULDERS 13 3/4"
- 11 EX AGGREGATE SHOULDERS
- 12 EX CONCRETE MEDIAN SURFACE 4"
- 13 EX COMBINATION CONCRETE CURB AND GUTTER TYPE M-6.06
- 14 EX PIPE UNDERDRAINS
- 15 EX STEEL PLATE BEAM GUARDRAIL
- 16 EX COMBINATION CONCRETE CURB AND GUTTER TYPE B-6.24
- 21 PR PAVEMENT REMOVAL
- 22 PR MEDIAN REMOVAL
- 23 PR PAVED SHOULDER REMOVAL
- 24 PR HOT-MIX ASPHALT SURFACE REMOVAL, VARIABLE DEPTH
- 25 PR SUBBASE GRANULAR MATERIAL, TYPE A 8"
- 26 PR HOT-MIX ASPHALT BASE COURSE, 10 1/2"
- 27 PR HOT-MIX ASPHALT BASE COURSE, 10 3/4"
- 28 PR HOT-MIX ASPHALT BASE COURSE, 12 1/4"
- 29 PR HOT-MIX ASPHALT BASE COURSE, 14 1/2"
- 30 PR LEVELING BINDER (MACHINE METHOD), N90 1 3/4"
- 31 PR HOT-MIX ASPHALT SURFACE COURSE, MIX "D", N90 1 1/2"
- 32 PR COMBINATION CONCRETE CURB AND GUTTER TYPE B-6.24
- 33 PR HOT-MIX ASPHALT SHOULDERS 1 1/2"
- 34 PR AGGREGATE WEDGE SHOULDERS, TYPE B
- 35 PR HOT-MIX ASPHALT SHOULDERS 12 1/4"
- 37 PR REMOVE AND ERECT STEEL PLATE BEAM GUARDRAIL
- 38 PR SUBBASE GRANULAR MATERIAL, TYPE A 12"
- 39 PR CONTINUOUSLY REINFORCED CONCRETE PAVEMENT 9"
- 43 PR STEEL PLATE BEAM GUARDRAIL TYPE A 6' POSTS
- 44 APPROACH SLAB REMOVAL
- 45 PR STEEL PLATE BEAM GUARDRAIL TYPE A 9' POSTS