

④  
 FAI ROUTE 55  
 STAGE 2 TYPICAL CROSS SECTIONS  
 SN 054-0065, 0066

NB I-55  
 STA 457+99.38 TO STA 458+99.38

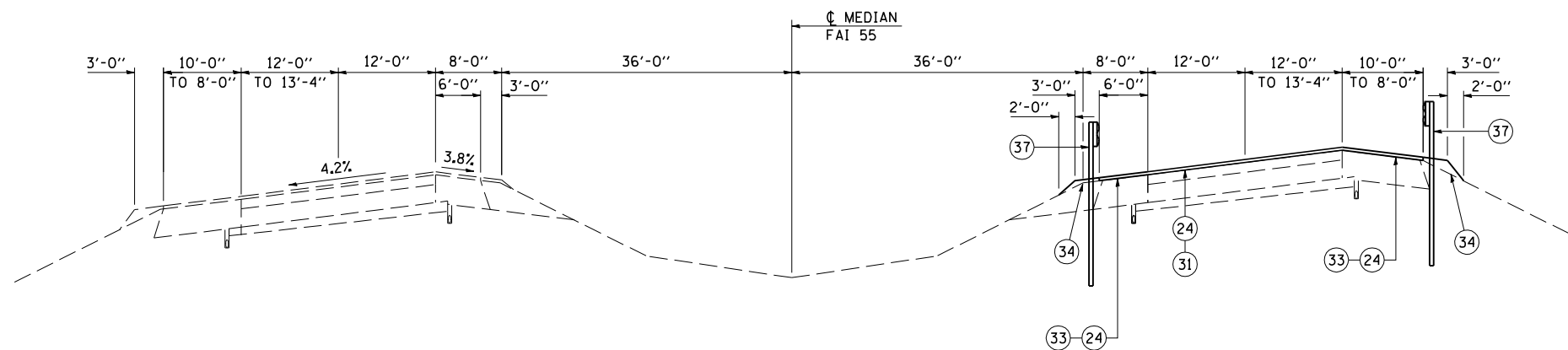

③  
 FAI ROUTE 55  
 STAGE 2 TYPICAL CROSS SECTIONS  
 SN 054-0065, 0066

NB I-55  
 STA 455+00.31 TO STA 456+00.31

OMISSIONS  
 BRIDGE APPROACH PAVEMENT CONNECTOR (PCC)  
 NB I-55 STA 456+01.12 TO STA 456+11.76  
 STA 457+87.32 TO STA 457+98.48  
 BRIDGE APPROACH PAVEMENT  
 NB I-55 STA 456+11.76 TO STA 456+41.76  
 STA 457+57.32 TO STA 457+87.32  
 BRIDGE  
 NB I-55 STA 456+41.76 TO STA 457+57.32

LEGEND

- 1 EX STABILIZED SUBBASE 4"
- 2 EX CONTINUOUSLY REINFORCED PORTLAND CEMENT CONCRETE PAVEMENT 9"
- 3 EX PORTLAND CEMENT CONCRETE PAVEMENT 8"
- 4 EX PORTLAND CEMENT CONCRETE PAVEMENT 10"
- 5 EX HOT-MIX ASPHALT RESURFACING 1 1/2"
- 6 EX HOT-MIX ASPHALT RESURFACING 3 1/4"
- 7 EX HOT-MIX ASPHALT RESURFACING 4 3/4"
- 8 EX HOT-MIX ASPHALT SHOULDERS 12"
- 9 EX HOT-MIX ASPHALT SHOULDERS 12 1/4"
- 10 EX HOT-MIX ASPHALT SHOULDERS 13 3/4"
- 11 EX AGGREGATE SHOULDERS
- 12 EX CONCRETE MEDIAN SURFACE 4"
- 13 EX COMBINATION CONCRETE CURB AND GUTTER TYPE M-6.06
- 14 EX PIPE UNDERDRAINS
- 15 EX STEEL PLATE BEAM GUARDRAIL
- 16 EX COMBINATION CONCRETE CURB AND GUTTER TYPE B-6.24
  
- 21 PR PAVEMENT REMOVAL
- 22 PR MEDIAN REMOVAL
- 23 PR PAVED SHOULDER REMOVAL
- 24 PR HOT-MIX ASPHALT SURFACE REMOVAL, VARIABLE DEPTH
- 25 PR SUBBASE GRANULAR MATERIAL, TYPE A 8"
- 26 PR HOT-MIX ASPHALT BASE COURSE, 10 1/2"
- 27 PR HOT-MIX ASPHALT BASE COURSE, 10 3/4"
- 28 PR HOT-MIX ASPHALT BASE COURSE, 12 1/4"
- 29 PR HOT-MIX ASPHALT BASE COURSE, 14 1/2"
- 30 PR LEVELING BINDER (MACHINE METHOD), N90 1 3/4"
- 31 PR HOT-MIX ASPHALT SURFACE COURSE, MIX "D", N90 1 1/2"
- 32 PR COMBINATION CONCRETE CURB AND GUTTER TYPE B-6.24
- 33 PR HOT-MIX ASPHALT SHOULDERS 1 1/2"
- 34 PR AGGREGATE WEDGE SHOULDERS, TYPE B
- 35 PR HOT-MIX ASPHALT SHOULDERS 12 1/4"
- 37 PR REMOVE AND ERECT STEEL PLATE BEAM GUARDRAIL
- 38 PR SUBBASE GRANULAR MATERIAL, TYPE A 12"
- 39 PR CONTINUOUSLY REINFORCED CONCRETE PAVEMENT 9"
- 43 PR STEEL PLATE BEAM GUARDRAIL TYPE A 6' POSTS
- 44 APPROACH SLAB REMOVAL
- 45 PR STEEL PLATE BEAM GUARDRAIL TYPE A 9' POSTS