

NOTES:

- TRAFFIC CONTROL AND PROTECTION SHALL BE AS SHOWN ON STANDARDS 701400 AND 701401
- THE CONTRACTOR SHALL SCHEDULE HIS OPERATIONS SO THAT ALL LANES ARE OPEN TO TRAFFIC FROM FRIDAY AT 12:00 PM UNTIL MONDAY AT 6:00 AM.
- THE TEMPORARY LIGHTING SYSTEM SHALL BE REMOVED AND ITEMS DEEMED SALVAGABLE UTILIZED IN THE PROPOSED TEMPORARY LIGHTING SYSTEM AT SN 054-0065, 66, 67, AND 68.

**SEQUENCE OF OPERATIONS SN 054-0057, 0058
PRESTAGE 1**

1. REMOVE TEMPORARY LIGHTING SYSTEM.
2. SAW CUT CROSSOVER PAVEMENT ALONG EDGE OF MEDIAN SHOULDER AND REMOVE PAVEMENT, STEEL PLATE BEAM GUARDRAIL, AND TRAFFIC BARRIER TERMINAL TYPE 1 (SPECIAL) TANGENT.
3. REGRADE MEDIAN DITCH AS SHOWN ON CROSS SECTION SHEETS
4. CONSTRUCT PAVEMENT PATCHES AND PARTIAL DEPTH BRIDGE PATCHES.
5. REMOVE OUTSIDE SHOULDERS, BRIDGE APPROACH SHOULDERS AND CONSTRUCT HMA BASE COURSE AND HMA SURFACE COURSE.
6. CONSTRUCT AGGREGATE WEDGE SHOULDERS TYPE B ALONG RECONSTRUCTED OUTSIDE SHOULDERS.
7. CONSTRUCT AGGREGATE WEDGE SHOULDER TYPE B ALONG MEDIAN SHOULDER.
8. REERECT STEEL PLATE BEAM GUARDRAIL AND TRAFFIC BARRIER TERMINAL TYPE 1 (SPECIAL) TANGENT ALONG MEDIAN SHOULDER.

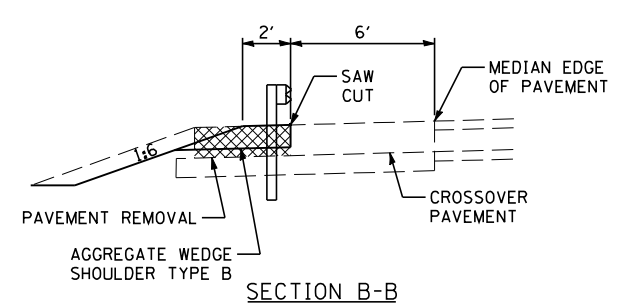
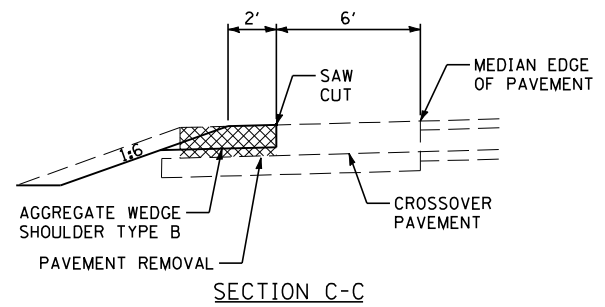

PR PAVED SHOULDER REMOVAL
PR HMA BASE COURSE 10 3/4 "
PR HMA SURFACE COURSE MIX "D" N90 1 1/2 "

INDICATES LIMITS OF PAVEMENT REMOVAL
 INDICATES LIMITS OF PAVED SHOULDER REMOVAL



| | | |
|-------------------------------------|-----------------|-----------|
| JOB = 2236.10 | DESIGNED - NAK | REVISED - |
| FILE NAME = D672E11-sh1-P1-5758.dgn | DRAWN - SJS | REVISED - |
| PLOT SCALE = 100.0000 ' / IN. | CHECKED - NAK | REVISED - |
| PLOT DATE = 3/18/2013 | DATE - 3/3/2011 | REVISED - |

**STATE OF ILLINOIS
DEPARTMENT OF TRANSPORTATION**

| | | |
|-----------------------------------|-------------------------|----------------------------|
| PRE-STAGE 1 | | |
| 054-0057 & SN 054-0058 | | |
| SCALE: | SHEET NO. 1 OF 2 SHEETS | STA. 560+00 TO STA. 575+00 |

| F.A.I. RTE. | SECTION | COUNTY | TOTAL SHEETS | SHEET NO. |
|---|-----------------------|--------|--------------------|-----------|
| 55 | D6 LOGAN CO BR 2011-1 | LOGAN | 429 | 103 |
| FED. ROAD DIST. NO. [ILLINOIS] FED. AID PROJECT | | | CONTRACT NO. 72E11 | |

MATCH LINE STA 575+00